

M62446AFP

6CH ELECTRONIC VOLUME WITH TONE CONTROL

DESCRIPTION

The M62446AFP is 6ch electronic volume with tone control. This IC is revised from M62446FP. The extended function of M62446AFP is volume level and tone control level. M62446AFP is easy to use more than M62446FP.

FEATURES (note) * is an extended function.

- 6ch Electric volume
Volume level : 0 to -95dB(1dB/step)*
<M62446FP:0 to -79dB(1dB/step)>
- Tone control
Bass/Treble : -14dB to +14dB(2dB/step)*
<M62446FP:-10dB to +10dB(2dB/step)>
- Noise voltage : 1.5μVrms <M62446FP:2.2μVrms>
- 4 Output ports
- Bypass mode is high quality sound.

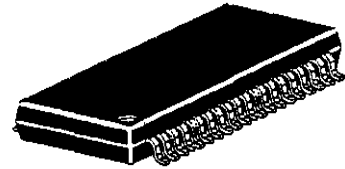

Outline 42P2R-A
0.8mm pitch 450mil ssop
(8.4mm×17.5mm×2.0mm)

APPLICATION

DVD, Home Audio equipment, TV

RECOMMENDED OPERATING CONDITIONS

Supply voltage range-----±4.5 to ±7.5V(analog), 4.5 to 5.5V(digital)

Recommended supply voltage-----±7.0V(analog), 5.0V(digital)

SYSTEM BLOCK DIAGRAM

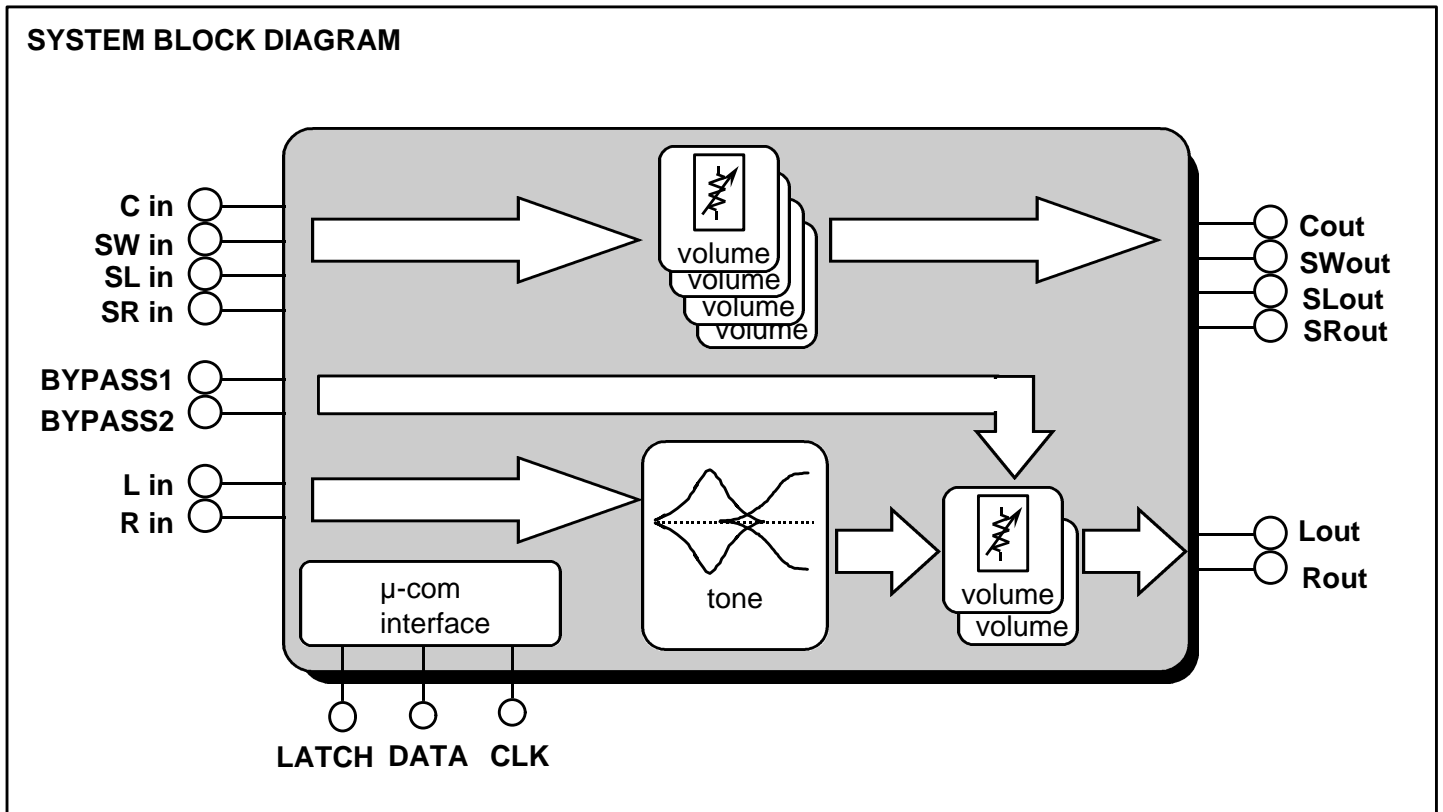

M62446AFP

6CH ELECTRONIC VOLUME WITH TONE CONTROL

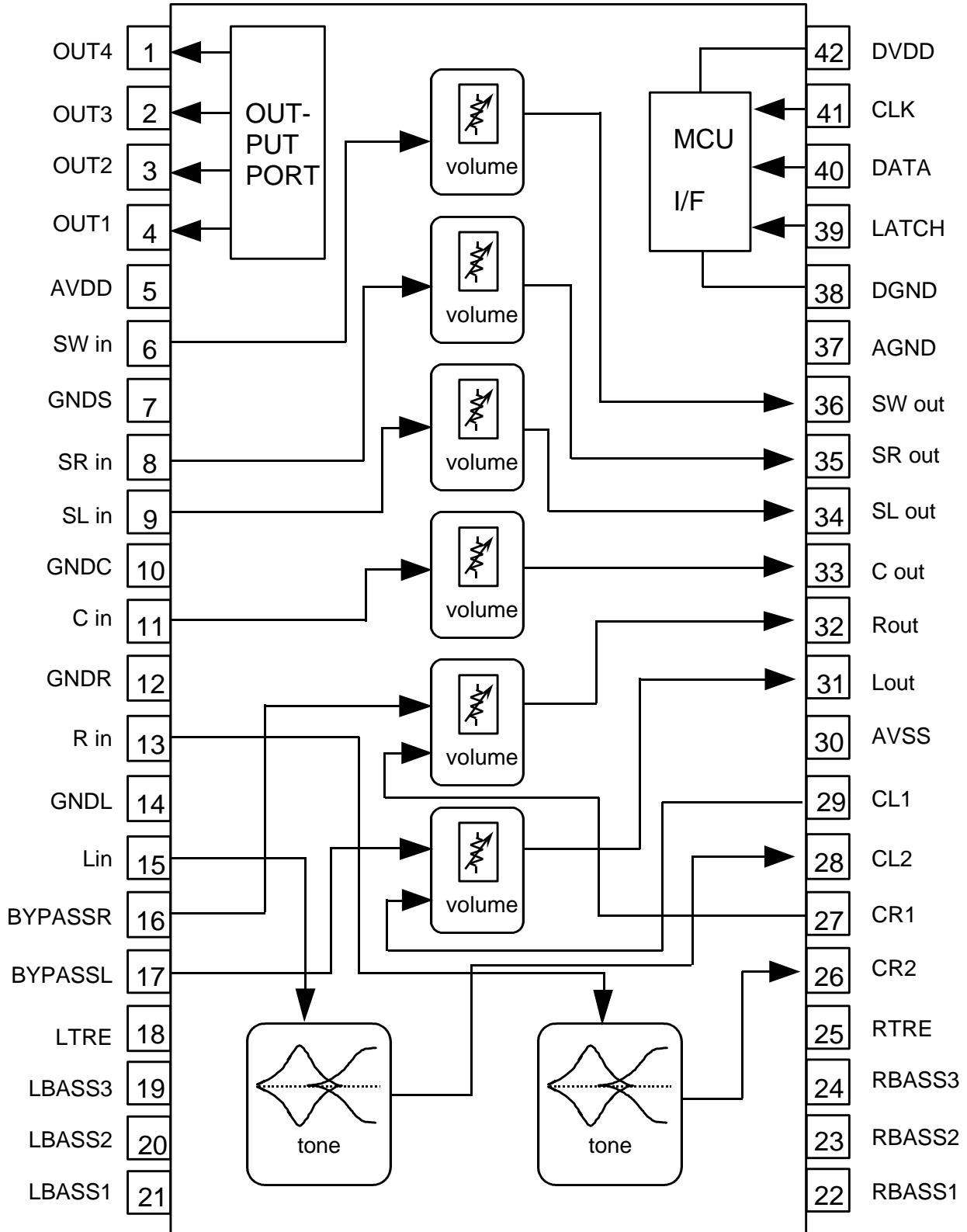

PIN CONFIGURATION AND BLOCK DIAGRAM



M62446AFP

6CH ELECTRONIC VOLUME WITH TONE CONTROL

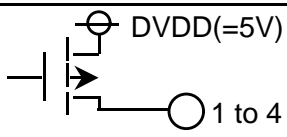
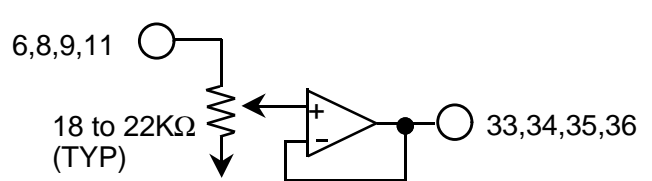
PIN DESCRIPTION

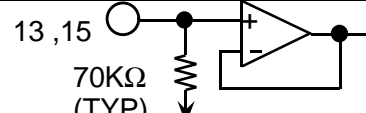
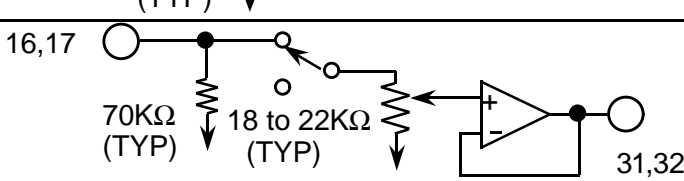
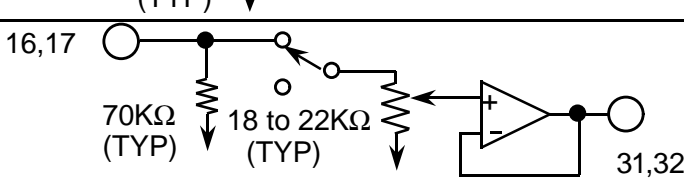
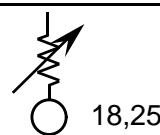
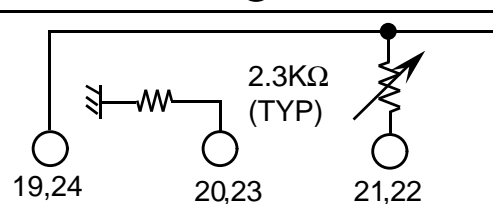
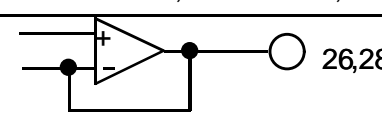
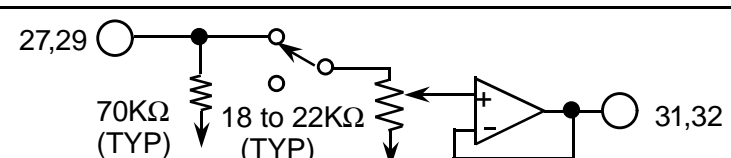
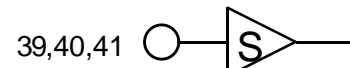
Pin No.	Symbol	Function	Circuit
1	OUT4	Port OUTPUT	OUTPUT:PMOS Transistor open drain 
2	OUT3		
3	OUT2		
4	OUT1		
5	AVDD	Analog positive Power supply	+7V
7	GNDS	GND	Connect to analog GND
10	GNDC		
12	GNDR		
14	GNDL		
6	SW in	Volume INPUT	
8	SR in		
9	SL in		
11	C in		
36	SW out	Volume OUTPUT	
35	SR out		
34	SL out		
33	C out		
13	R in	Tone INPUT	
15	L in		
16	BYPASSR	L,R Volume INPUT in BYPASS mode	
17	BYPASSL		
31	Lout	L OUTPUT	
32	Rout	R OUTPUT	
18	LTRE	tone Treble cycle control	
25	RTRE		
19	LBASS3	tone Bass cycle control	
24	RBASS3		
20	LBASS2		
23	RBASS2		
21	LBASS1		
26	RBASS1		
22	CR2	Tone OUTPUT	
28	CL2		
27	CR1	L,R Volume INPUT	
29	CL1		
31	Lout		
32	Rout		
30	AVSS	Analog negative Power Supply	-7V
37	AGND	Analog GND	
38	DGND	Digital GND	
39	LATCH	Latch INPUT	
40	DATA	Data INPUT	
41	CLK	Clock INPUT Forward data	
42	DVDD	Digital Power supply	+5V

6CH ELECTRONIC VOLUME WITH TONE CONTROL

ABSOLUTE MAXIMUM RATINGS

Symbol	Parameter	Condition	Ratings	Unit
Vsupply	Supply Voltage	AVDD-AVSS	16	V
		DVDD-DGND	7	
Pd	Power dissipation	Ta ≤ 25 °C	1000	mW
Kθ	Thermal derating	Ta > 25 °C	10	mW/°C
Topr	Operating temperature		-20 to +75	°C
Tstg	Storage temperature		-40 to +125	°C

THERMAL DERATING(MAXMUM RATING)
(with the standard board)

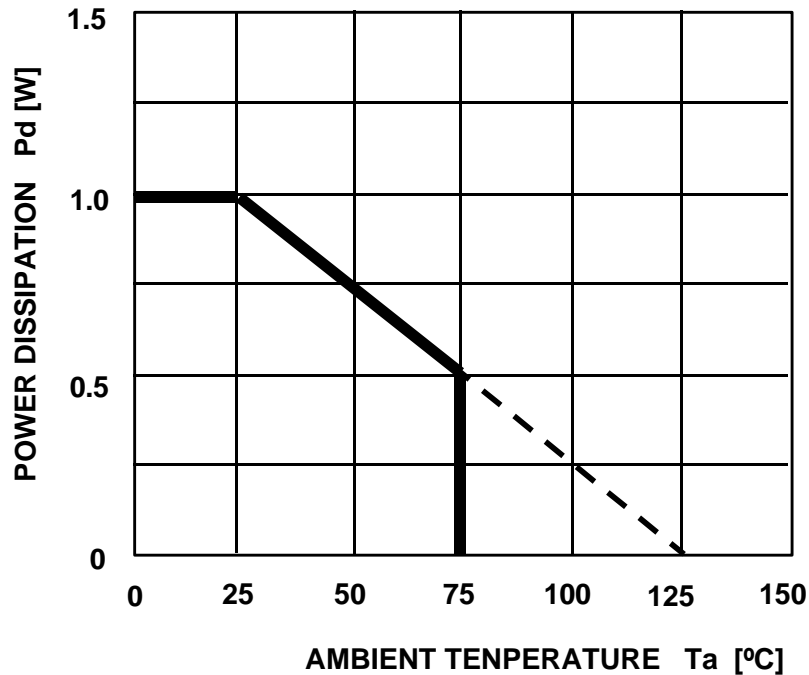

*Standard board

- board size 70mm X 70mm
- board thickness 1.6mm
- board material glass epoxy
- copper pattern
 - copper thickness 18μm
 - copper size 0.25mm(wide) 30mm(length/lead)

6CH ELECTRONIC VOLUME WITH TONE CONTROL

RECOMMENDED OPERATING CONDITION

(Ta=25°C, unless otherwise noted.)

Parameter	Symbol	Condition	MIN	TYP	MAX	Unit
Analog positive Supply Voltage	AVDD		4.5	7.0	7.5	V
Analog negative Supply Voltage	AVSS		-7.5	-7.0	-4.5	V
Digital Supply Voltage	DVDD		4.5	5.0	5.5	V
High-level Input Voltage	VIH		DVDD×0.7	—	DVDD	V
Low-level Input Voltage	VIL		DGND	—	DVDD×0.3	V

(Note) $AVSS \leq DGND < DVDD \leq AVDD$

RELATIONSHIP BETWEEN DATA AND CLOCK AND LATCH

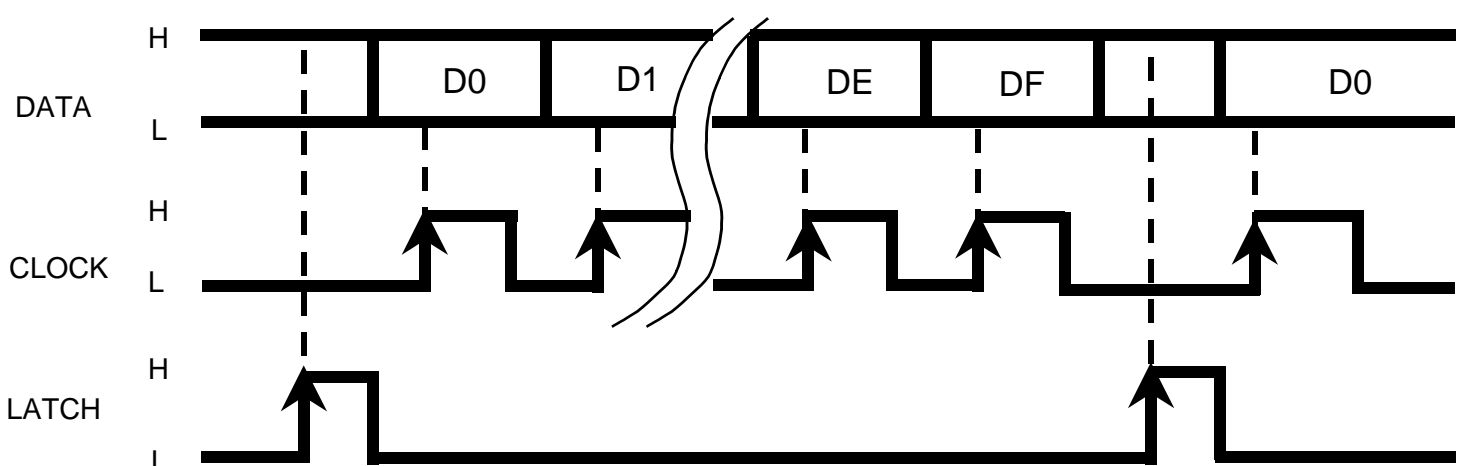

note : CLOCK and LATCH function at raising edges of pulse .

6CH ELECTRONIC VOLUME WITH TONE CONTROL

DATA TIMING(Recommended conditions)

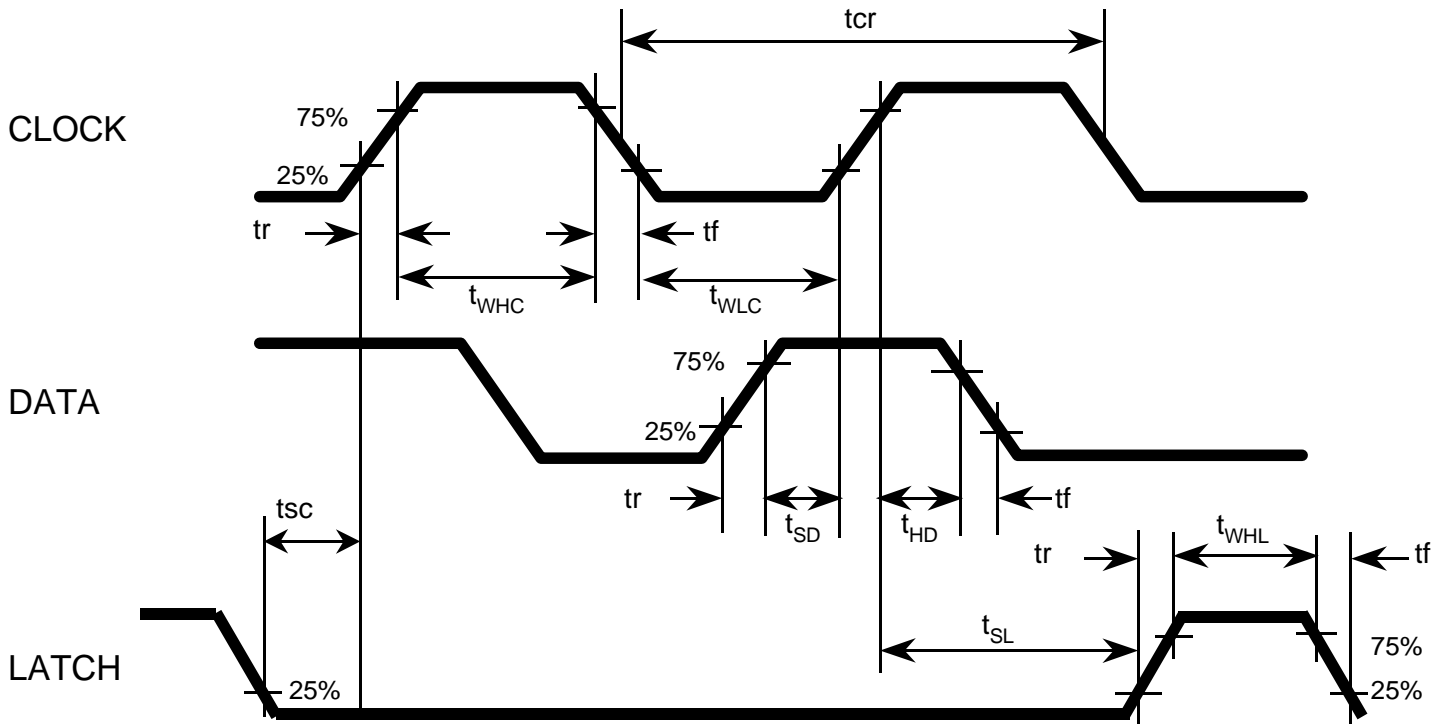

DIGITAL BLOCK TIMING REGULATION

Symbol	Parameter	Limits			Unit
		Min	typ	Max	
t_{cr}	CLOCK cycle time	8	-	-	μsec
t_{WHC}	CLOCK pulse width ("H"level)	3.2	-	-	
t_{WLC}	CLOCK pulse width ("L"level)	3.2	-	-	
t_r	CLOCK,DATA,LATCH rise time	-	-	0.8	
t_f	CLOCK,DATA,LATCH fall time	-	-	0.8	
t_{SD}	DATA setup time	1.6	-	-	
t_{HD}	DATA hold time	1.6	-	-	
t_{SL}	LATCH setup time	2	-	-	
t_{WHL}	LATCH pulse width	3.2	-	-	
t_{SC}	CLOCK start time after LACTH	3.2	-	-	

6CH ELECTRONIC VOLUME WITH TONE CONTROL

DIGITAL CONTROL SPECIFICATION

Fore kinds of input format options are available by changing slot settings of DE and DF.
 (When the IC is powered up , the internal settings are not fixed.)

(1)

D01	D11	D21	D31	D41	D51	D61	D71	D81	D91	DA1	DB1	DC1	DD1	DE	DF
TONE CONT TLEBLE				1	2	3	4	TONE CONT BASS				0	TONE :0 BYPASS :1	0	0
				OUTPUT PORT n CONT High:1,Low:0											

(2)

D02	D12	D22	D32	D42	D52	D62	D72	D82	D92	DA2	DB2	DC2	DD2	DE	DF
VOLUME Lch							VOLUME Rch							0	1

(3)

D03	D13	D23	D33	D43	D53	D63	D73	D83	D93	DA3	DB3	DC3	DD3	DE	DF
VOLUME Cch							VOLUME SWch							1	0

(4)

D04	D14	D24	D34	D44	D54	D64	D74	D84	D94	DA4	DB4	DC4	DD4	DE	DF
VOLUME SLch							VOLUME SRch							1	1

SETTING CODE

(1) Tone control (bass / treble)

(Note) * is an extended function.

ATT	Treble	D01	D11	D21	D31
	bass	D81	D91	DA1	DB1
* - 14dB		1	1	1	1
* - 12dB		1	1	0	1
- 10dB		1	1	1	0
- 8dB		1	1	0	0
- 6dB		1	0	1	1
- 4dB		1	0	1	0
- 2dB		1	0	0	1
+ 0dB		0	0	0	0
+ 2dB		0	0	0	1
+ 4dB		0	0	1	0
+ 6dB		0	0	1	1
+ 8dB		0	1	0	0
+ 10dB		0	1	1	0
* + 12dB		0	1	0	1
* + 14dB		0	1	1	1

(2) Port output

D41	D51
D61	D71
Out:H	1
Out:L	0

(3) BYPASS control

DD1	
BYPASS	1
TONE	0

Note : Do not input other data than the above.

6CH ELECTRONIC VOLUME WITH TONE CONTROL

(4)-1 VOLUME (0 to -39dB)

Note : Do not input other data than the above.

A T T	VOLUME	D0X	D1X	D2X	D3X	D4X	D5X	D6X
		D7X	D8X	D9X	DAX	DBX	DCX	DDX
	0dB	0	0	0	0	0	0	0
	-1dB	0	0	0	0	0	0	1
	-2dB	0	0	0	0	0	1	0
	-3dB	0	0	0	0	0	1	1
	-4dB	0	0	0	0	1	0	0
	-5dB	0	0	0	0	1	0	1
	-6dB	0	0	0	0	1	1	0
	-7dB	0	0	0	0	1	1	1
	-8dB	0	0	0	1	0	0	0
	-9dB	0	0	0	1	0	0	1
	-10dB	0	0	0	1	0	1	0
	-11dB	0	0	0	1	0	1	1
	-12dB	0	0	0	1	1	0	0
	-13dB	0	0	0	1	1	0	1
	-14dB	0	0	0	1	1	1	0
	-15dB	0	0	0	1	1	1	1
	-16dB	0	0	1	0	0	0	0
	-17dB	0	0	1	0	0	0	1
	-18dB	0	0	1	0	0	1	0
	-19dB	0	0	1	0	0	1	1
	-20dB	0	0	1	0	1	0	0
	-21dB	0	0	1	0	1	0	1
	-22dB	0	0	1	0	1	1	0
	-23dB	0	0	1	0	1	1	1
	-24dB	0	0	1	1	0	0	0
	-25dB	0	0	1	1	0	0	1
	-26dB	0	0	1	1	0	1	0
	-27dB	0	0	1	1	0	1	1
	-28dB	0	0	1	1	1	0	0
	-29dB	0	0	1	1	1	0	1
	-30dB	0	0	1	1	1	1	0
	-31dB	0	0	1	1	1	1	1
	-32dB	0	1	0	0	0	0	0
	-33dB	0	1	0	0	0	0	1
	-34dB	0	1	0	0	0	1	0
	-35dB	0	1	0	0	0	1	1
	-36dB	0	1	0	0	1	0	0
	-37dB	0	1	0	0	1	0	1
	-38dB	0	1	0	0	1	1	0
	-39dB	0	1	0	0	1	1	1

6CH ELECTRONIC VOLUME WITH TONE CONTROL

(4)-2 VOLUME(-40 to - dB)

Note : Do not input other data than the above.

A T T	VOLUME	D0X	D1X	D2X	D3X	D4X	D5X	D6X
		D7X	D8X	D9X	DAX	DBX	DCX	DDX
	-40dB	0	1	0	1	0	0	0
	-41dB	0	1	0	1	0	0	1
	-42dB	0	1	0	1	0	1	0
	-43dB	0	1	0	1	0	1	1
	-44dB	0	1	0	1	1	0	0
	-45dB	0	1	0	1	1	0	1
	-46dB	0	1	0	1	1	1	0
	-47dB	0	1	0	1	1	1	1
	-48dB	0	1	1	0	0	0	0
	-49dB	0	1	1	0	0	0	1
	-50dB	0	1	1	0	0	1	0
	-51dB	0	1	1	0	0	1	1
	-52dB	0	1	1	0	1	0	0
	-53dB	0	1	1	0	1	0	1
	-54dB	0	1	1	0	1	1	0
	-55dB	0	1	1	0	1	1	1
	-56dB	0	1	1	1	0	0	0
	-57dB	0	1	1	1	0	0	1
	-58dB	0	1	1	1	0	1	0
	-59dB	0	1	1	1	0	1	1
	-60dB	0	1	1	1	1	0	0
	-61dB	0	1	1	1	1	0	1
	-62dB	0	1	1	1	1	1	0
	-63dB	0	1	1	1	1	1	1
	-64dB	1	0	0	0	0	0	0
	-65dB	1	0	0	0	0	0	1
	-66dB	1	0	0	0	0	1	0
	-67dB	1	0	0	0	0	1	1
	-68dB	1	0	0	0	1	0	0
	-69dB	1	0	0	0	1	0	1
	-70dB	1	0	0	0	1	1	0
	-71dB	1	0	0	0	1	1	1
	-72dB	1	0	0	1	0	0	0
	-73dB	1	0	0	1	0	0	1
	-74dB	1	0	0	1	0	1	0
	-75dB	1	0	0	1	0	1	1
	-76dB	1	0	0	1	1	0	0
	-77dB	1	0	0	1	1	0	1
	-78dB	1	0	0	1	1	1	0
	-79dB	1	0	0	1	1	1	1
	-∞dB	1	0	1	0	0	0	0

6CH ELECTRONIC VOLUME WITH TONE CONTROL

ELECTRICAL CHARACTERISTICS

(Ta=25°C, AVDD/AVSS/DVDD=7/-7V/5V, f=1kHz, unless otherwise noted.
Rg=1KΩ, RL=10KΩ, TONE CONTROL • VOL are set to 0dB/FLAT.)

(1) Power supply characteristics

Parameter	Symbol	Test condition	Limits			Unit
			Min	typ	Max	
Analog positive circuit current	A _{ldd}	Current at pin 5 No signal	—	22	35	mA
Analog negative circuit current	A _{lss}	Current at pin 30 No signal	—	22	35	mA
Digital circuit current	D _{ldd}	Current at pin 42 No signal	—	1.0	2.0	mA

(2) Input / Output characteristics

Parameter	Symbol	Test condition	Limits			Unit
			Min	typ	Max	
Input resistance	R _i	13,15,16,17,27,29pin	35	70	150	KΩ
Maximum output voltage	V _{OM}	6,8,9,11,13,15,16,17pinINPUT 31 to 36pinOUTPUT THD=1%	3.0	4.2	—	V _{rms}
Pass gain	G _v	V _i =0.2V _{rms} ,FLAT .8,9,11,13,15,16,17pinINPUT 31 to 36pinOUTPUT	-2.0	0	2.0	dB
Distortion	THD	BW=400 to 30KHz V _i =0.2V _{rms} , RL=10KΩ	—	0.002	0.09	%
Output noise voltage	V _n (VOL)	31 to 36pin,Rg=0KΩ, JIS-A,VOL=0dB	—	1.5	6	μV _{rms}
	V _n (tone)	31,32pin JIS-A,VOL=0dB	—	5	20	μV _{rms}
Maximum attenuation	ATT _{max}	31 to 36pin JIS-A,VOL=-∞dB	—	-100	-95	dB
Volume gain between channels	D _{vol}		-1.5	0	1.5	dB
Crosstalk between channels	CT	V _o =0.5V _{rms} , RL=10KΩ,JIS-A Rg=1KΩ	—	-80	-65	dB
Port output current	I _L		0.2	—	—	mA

6CH ELECTRONIC VOLUME WITH TONE CONTROL

(3) Tone control characteristics

(Note) * is an expanded function.

Parameter	Symbol	Test condition	Limits			Unit
			Min	typ	Max	
Tone control voltage gain	* T +14dB	Vo=0.2Vrms TLEBLE(f=10kHz), BASS(f=100Hz)	12	14	16	dB
	* T +12dB		10	12	14	dB
	T +10dB		8	10	12	dB
	T +8dB	Voltage gain (Input to pin13,15 Output from pin31,32)	6	8	10	dB
	T +6dB		4.5	6	7.5	dB
	T +4dB	INPUT 13,15pin OUTPUT 31,32pin	2.5	4	5.5	dB
	T +2dB		1	2	3	dB
	T -2dB		-3	-2	-1	dB
	T -4dB		-5.5	-4	-2.5	dB
	T -6dB		-7.5	-6	-4.5	dB
	T -8dB		-10	-8	-6	dB
	T -10dB		-12	-10	-8	dB
	* T -12dB		-14	-12	-10	dB
	* T -14dB	-16	-14	-12	dB	
Balance between channel	BALT	Input 13 ,15pin Vo=0.2Vrms Output31,32pin	-1.5	0	+1.5	dB

M62446AFP

6CH ELECTRONIC VOLUME WITH TONE CONTROL

TEST CIRCUIT

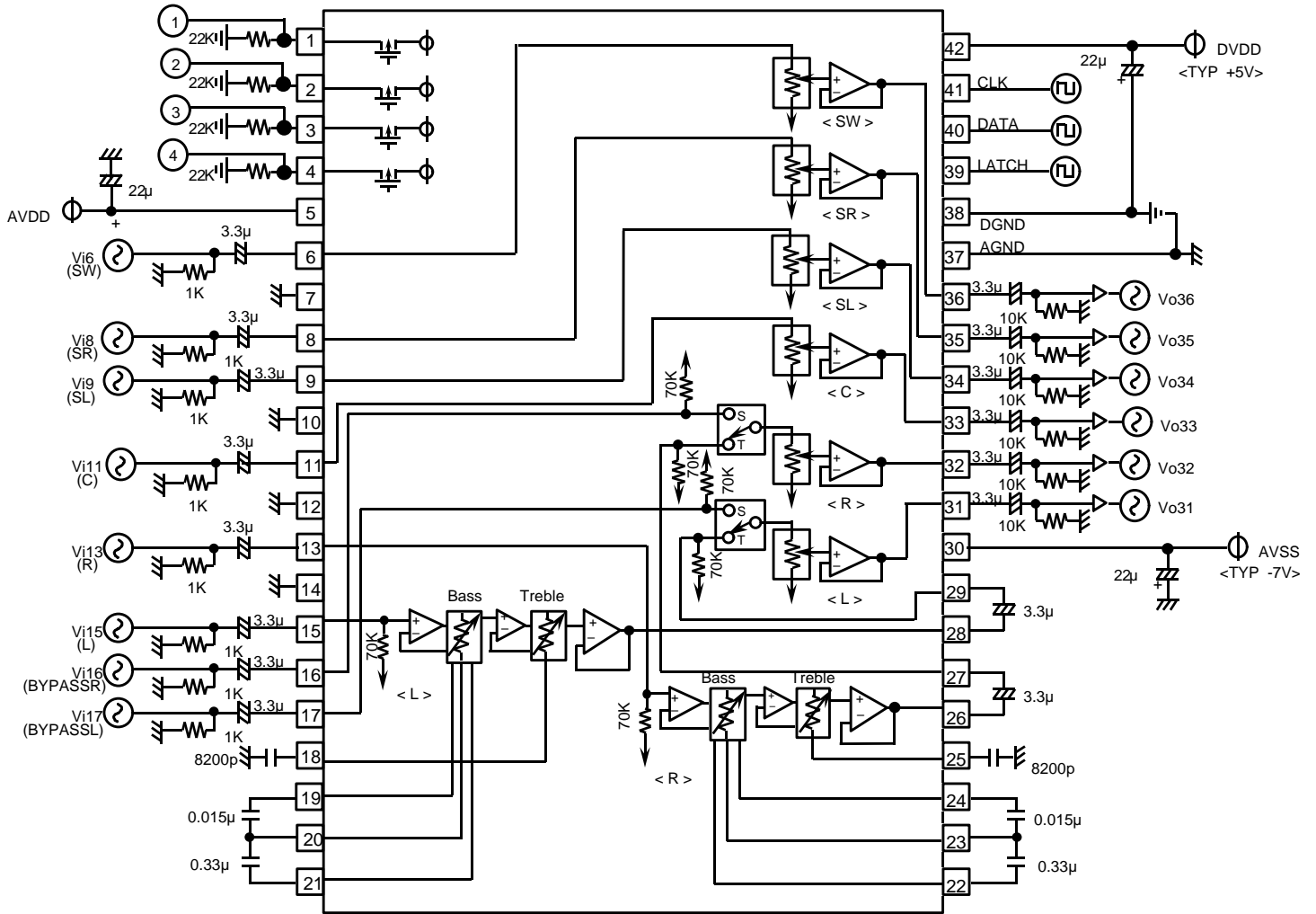

6CH ELECTRONIC VOLUME WITH TONE CONTROL

SIGNAL PROCESSING DIAGRAM

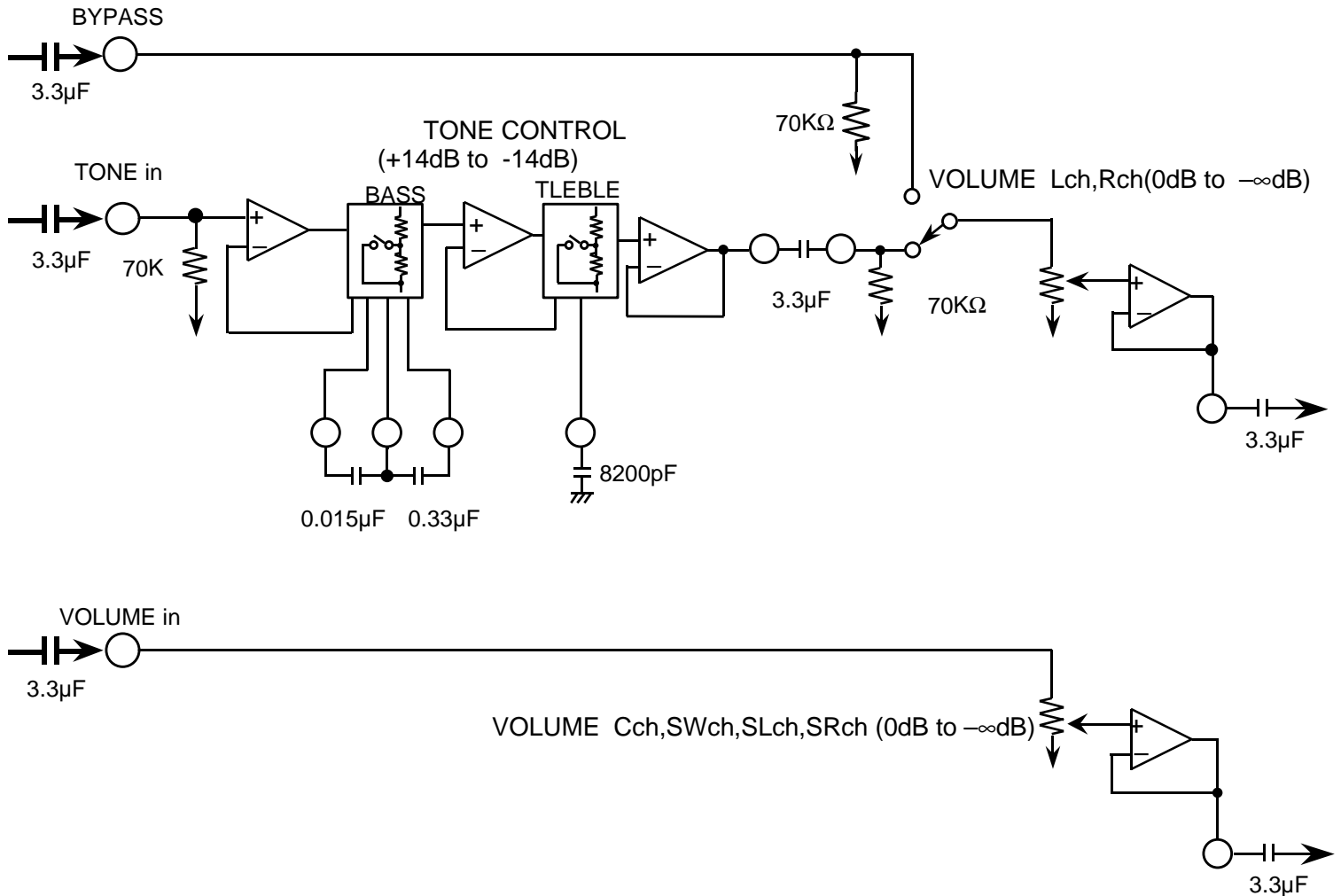

Note.(1)The resistance value of Volume change about 18 to 22K by attenuated condition.
 (2)No built in a zero cross circuit.
 (3)When the mode changed(BYPASS/TONE),it is necessary the muting function.

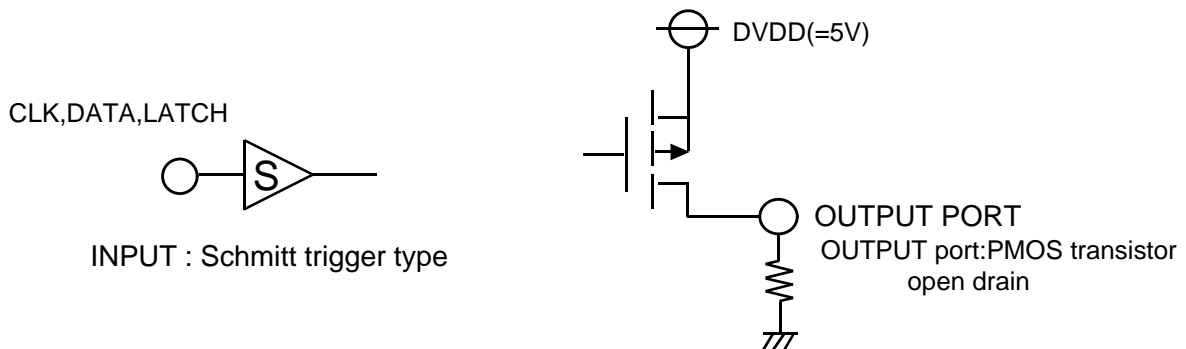

M62446AFP

6CH ELECTRONIC VOLUME WITH TONE CONTROL

APPLICATION EXAMPLE

(When using Tone control and Bypass)

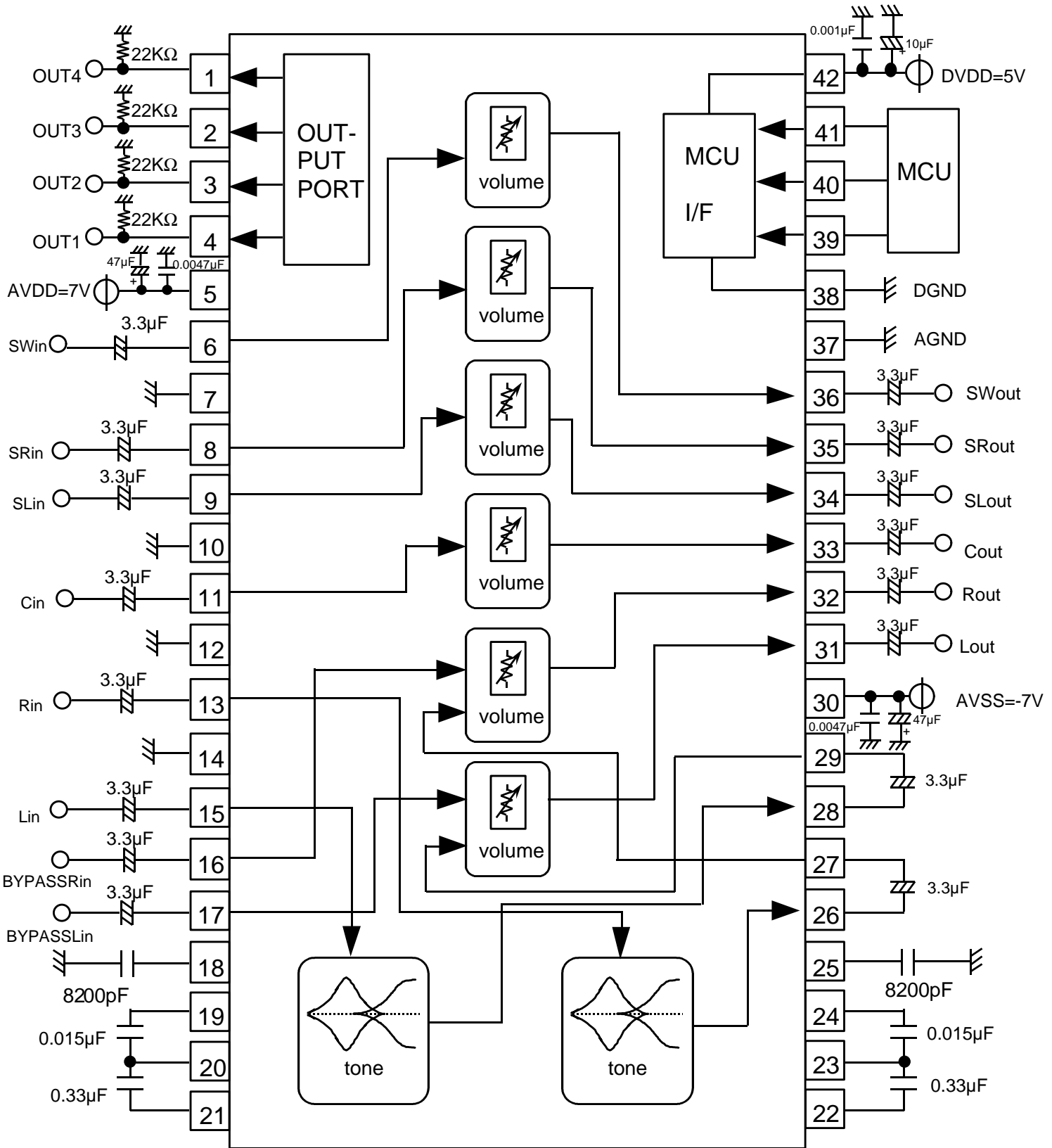

M62446AFP

6CH ELECTRONIC VOLUME WITH TONE CONTROL

DETAILED DIAGRAM OF PACKAGE OUTLINE

42P2R-A

(MMP)

Plastic 42pin 450mil SSOP

EIAJ Package Code	JEDEC Code	Weight(g)	Lead Material
SSOP42-P-450-0.80	-	0.63	Alloy 42/Cu Alloy

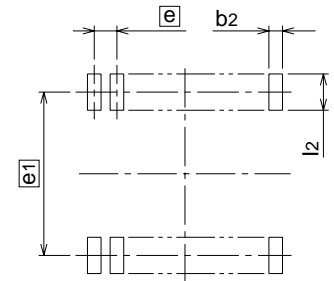
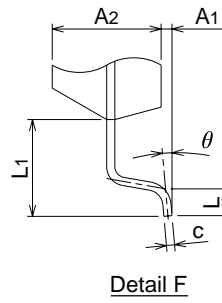
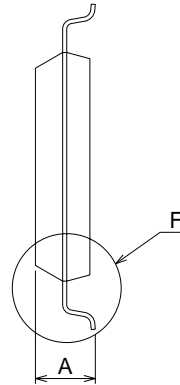
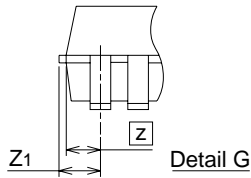
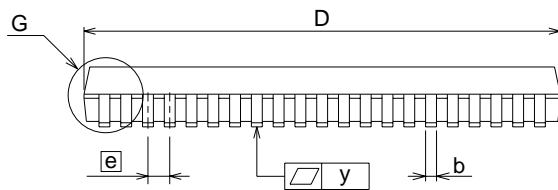
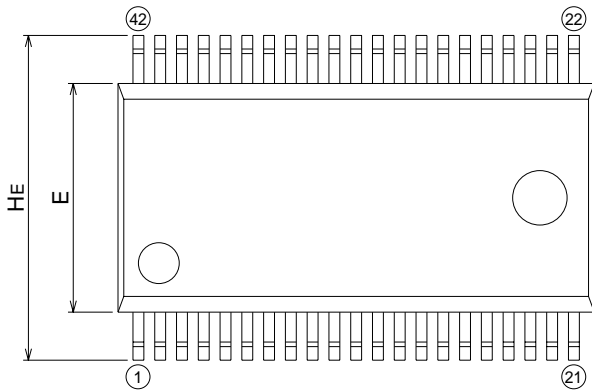

Recommended Mount Pad

Symbol	Dimension in Millimeters		
	Min	Nom	Max
A	-	-	2.4
A1	0.05	-	-
A2	-	2.0	-
b	0.35	0.4	0.5
c	0.13	0.15	0.2
D	17.3	17.5	17.7
E	8.2	8.4	8.6
e	-	0.8	-
HE	11.63	11.93	12.23
L	0.3	0.5	0.7
L1	-	1.765	-
Z	-	0.75	-
Z1	-	-	0.9
y	-	-	0.15
θ	0°	-	10°
b2	-	0.5	-
e1	-	11.43	-
l2	1.27	-	-

Keep safety first in your circuit designs!

●Mitsubishi Electric Corporation puts the maximum effort into making semiconductor products better and more reliable, but there is always the possibility that trouble may occur with them. Trouble with semiconductors may lead to personal injury, fire or property damage. Remember to give due consideration to safety when making your circuit designs, with appropriate measures such as (i) placement of substitutive, auxiliary circuits, (ii) use of non-flammable material or (iii) prevention against any malfunction or mishap.

Notes regarding these materials

●These materials are intended as a reference to assist our customers in the selection of the Mitsubishi semiconductor product best suited to the customer's application; they do not convey any license under any intellectual property rights, or any other rights, belonging to Mitsubishi Electric Corporation or a third party.
 ●Mitsubishi Electric Corporation assumes no responsibility for any damage, or infringement of any third-party's rights, originating in the use of any product data, diagrams, charts, programs, algorithms, or circuit application examples contained in these materials.

●All information contained in these materials, including product data, diagrams, charts, programs and algorithms represents information on products at the time of publication of these materials, and are subject to change by Mitsubishi Electric Corporation without notice due to product improvements or other reasons. It is therefore recommended that customers contact Mitsubishi Electric Corporation or an authorized Mitsubishi Semiconductor product distributor for the latest product information before purchasing a product listed herein. The information described here may contain technical inaccuracies or typographical errors. Mitsubishi Electric Corporation assumes no responsibility for any damage, liability, or other loss rising from these inaccuracies or errors.

Please also pay attention to information published by Mitsubishi Electric Corporation by various means, including the Mitsubishi Semiconductor home page (<http://www.mitsubishichips.com>).

●When using any or all of the information contained in these materials, including product data, diagrams, charts, programs, and algorithms, please be sure to evaluate all information as a total system before making a final decision on the applicability of the information and products. Mitsubishi Electric Corporation assumes no responsibility for any damage, liability or other loss resulting from the information contained herein.

●Mitsubishi Electric Corporation semiconductors are not designed or manufactured for use in a device or system that is used under circumstances in which human life is potentially at stake. Please contact Mitsubishi Electric Corporation or an authorized Mitsubishi Semiconductor product distributor when considering the use of a product contained herein for any specific purposes, such as apparatus or systems for transportation, vehicular, medical, aerospace, nuclear, or undersea repeater use.

●The prior written approval of Mitsubishi Electric Corporation is necessary to reprint or reproduce in whole or in part these materials.

●If these products or technologies are subject to the Japanese export control restrictions, they must be exported under a license from the Japanese government and cannot be imported into a country other than the approved destination.

Any diversion or reexport contrary to the export control laws and regulations of Japan and/or the country of destination is prohibited.

●Please contact Mitsubishi Electric Corporation or an authorized Mitsubishi Semiconductor product distributor for further details on these materials or the products contained therein.

This datasheet has been download from:

www.datasheetcatalog.com

Datasheets for electronics components.