

φ 40 Body Standard / Hollow Shaft Type

Diameter φ 40mm Shaft type/Hollow type/Built-in type INCREMENTAL Rotary encoder

■ Features

- Easy installation at narrow space
- Small inertia moment
- Wide range of power source :
5VDC, 12-24VDC ±5%
- Various output types

⚠ Please read "Caution for your safety" in operation manual before using.



■ Ordering information

E40 **H** **8** **5000** **3** **2** **24**

Series	Shaft type	Hollow type	Pulse/1 Revolution	Output phase	Output	Power supply	Cable
S: Shaft type H: Hollow type HB: Hollow built-in type	Outside (*) No mark: φ 6mm 8: φ 8mm	Inside 6: φ 6mm 8: φ 8mm 10: φ 10mm 12: φ 12mm	See resolution	2: A, B 3: A, B, Z 4: A, \bar{A} , B, \bar{B} 6: A, \bar{A} , B, \bar{B} , Z, \bar{Z}	1: Totem pole output 2: NPN open collector output 3: Voltage output L: Line driver output(*)	5 : 5VDC ±5% 24: 12-24VDC ±5%	No mark: Normal type (*) 2C: Cable outgoing connector type

* Standard : E40S6-**[PULSE]**-3-2-24
E40H8-**[PULSE]**-3-2-24
E40HB8-**[PULSE]**-3-2-24 } 12-24VDC

* Standard: A, B, Z * The power of Line driver is only for 5VDC

* Cable length : 200mm

■ Specifications

Item		Diameter φ 40mm shaft type Incremental Rotary encoder	
Resolution(P/R)		(★Note1) *1, *2, *5, 10, *12, 15, 20, 23, 25, 30, 35, 40, 45, 50, 60, 75, 100, 120, 150, 192, 200, 240, 250, 256, 300, 360, 400, 500, 512, 600, 800, 1000, 1024, 1200, 1500, 1800, 2000, 2048, 2500, 3000, 3600, 5000 (Not indicated type is available to customize)	
Electrical specification	Phase difference of output	Output between A and B phase : $\frac{T}{4} \pm \frac{T}{8}$ (T=1 cycle of A phase)	
	Control output	Totem pole output	• Low \Rightarrow Load current : Max. 30mA, Residual voltage : Max. 0.4VDC • High \Rightarrow Load current : Max. 10mA, Output voltage : Min. (Power voltage-1.5)VDC
		NPN open collector output	Load current : Max. 30mA, Residual voltage : Max. 0.4VDC
		Voltage output	Load current : Max. 10mA, Residual voltage : Max. 0.4VDC
		Line driver output	Low \Rightarrow Load current : Max. 20mA, Residual : Max. 0.5V High \Rightarrow Load current : Max. -20mA, Output voltage : Min. 2.5V
	Response time (Rise/Fall)	Totem pole output	Max. 1μs
		NPN open collector output	Max. 1μs
		Voltage output	Max. 1μs
		Line driver output	Max. 0.5μs
	Max. Response frequency		180kHz
Current consumption		Max. 60mA (disconnection of the load), Line driver output: Max. 50mA (disconnection of the load)	
Insulation resistance		Min. 100MΩ (at 500VDC)	
Dielectric strength		750VAC 50/60Hz for 1 minute (Between all terminals and case)	
Connection		Cable outgoing type, 200mm cable outgoing connector type	
Mechanical specification	Starting torque	Shaft Type : Max. 40gf · cm (0.004N · m), Holl Type : Max. 50gf · cm (0.005N · m)	
	Moment of inertia	Max. 40g · cm ² (2 × 40 ⁻⁶ kg · m ²)	
	Shaft loading	Radial : Max. 2kgf, Thrust : Max. 1kgf	
	Deviation of shaft position	Radial : Max. 0.1mm, Thrust : Max. 0.2mm	
	Max. allowable revolution	(★Note2) 5000rpm	
Vibration		1.5mm amplitude at frequency of 10 ~ 55Hz in each of X, Y, Z directions for 2 hours	
Shock		Max. 50G	
Ambient temperature		-10 ~ 70°C (at non-freezing status), Storage: -25 ~ 85°C	
Ambient humidity		35~85%RH, Storage: 35~90%RH	
Protection		IP50 (IEC specification)	
Cable		5P, φ 5mm, Length : 2m, Shield cable (Line driver output : 8P, φ 5mm)	
Accessory		φ 6mm coupling standard, φ 8mm coupling (Option) [Applied only for shaft type]	
Weight		Approx. 120g	
Approval		CE (Except Line driver output)	

※ (★Note1) * pulse is only for A, B phase (Line Driver output is A, \bar{A} , B, \bar{B} phase)

※ (★Note2) Max. allowable revolution \geq Max. response revolution [Max. response revolution (rpm) = $\frac{\text{Max. response frequency}}{\text{Resolution}} \times 60 \text{ sec}$]

Please select the resolution to make lower max. revolution than max. allowable revolution.

(A) Counter

(B) Timer

(C) Temp. controller

(D) Power controller

(E) Panel meter

(F) Tacho/Speed/Pulse meter

(G) Display unit

(H) Sensor controller

(I) Proximity sensor

(J) Photo electric sensor

(K) Pressure sensor

(L) Rotary encoder

(M) 5-Phase stepping motor & Driver & Controller

E40 Series

Control output diagram

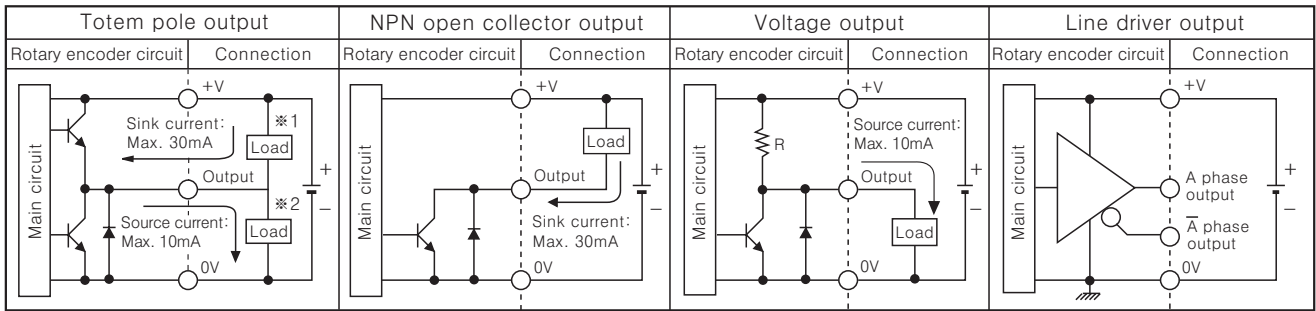

☞ Totem pole output type can be used for NPN open collector output type(*1) or Voltage output type(*2).

☞ All output circuits are the same A, B, Z phase(Line driver output is A, A-bar, B, B-bar, Z, Z-bar)

Output waveform

- Totem pole output / NPN open collector output / Voltage output
- Line driver output

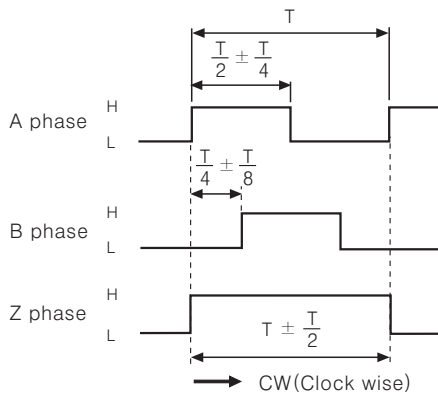

※ Inverse type of Z phase is optional.

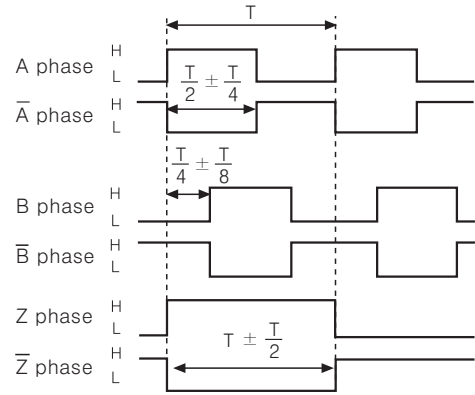

※ CW : In a view of shaft

Connections

Normal type

- Totem pole output / NPN open collector output / Voltage output

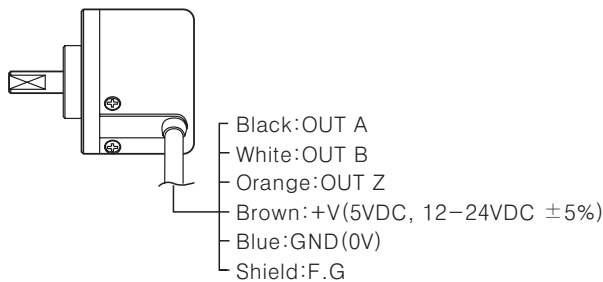

- ※ Unused wires must be insulated.
- ※ The body of encoder is connected to a shield.

- Line driver output

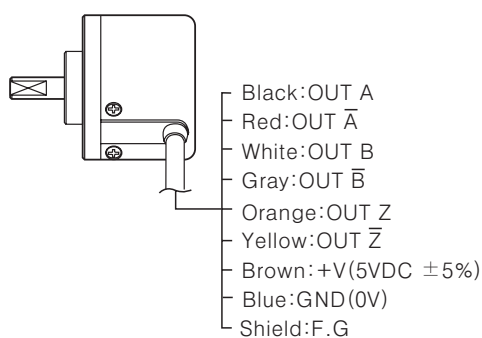

Cable outgoing connector type

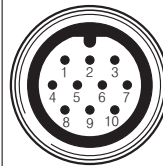

Pin No.	Cable color	Totem pole output NPN open collector output Voltage output	Line driver output
①	Black	OUT A	OUT A
②	Red	N.C	OUT A-bar
③	Brown	+V	+V
④	Blue	GND	GND
⑤	White	OUT B	OUT B
⑥	Gray	N.C	OUT B-bar
⑦	Orange	OUT Z	OUT Z
⑧	Yellow	N.C	OUT Z-bar
⑨	Shield	F.G	F.G
⑩	Purple	N.C	N.C

- ※ N.C(Not Connected)
- ※ F.G(Field Ground)

φ 40 Body Standard / Hollow Shaft Type

■ Dimensions

■ Normal type

● Shaft type

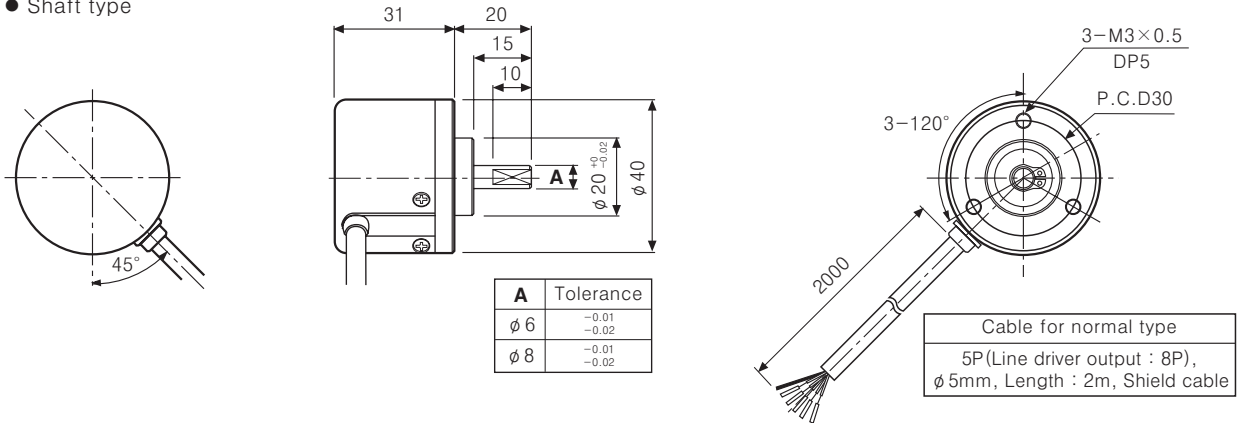

● Hollow shaft / Hollow shaft built-in type

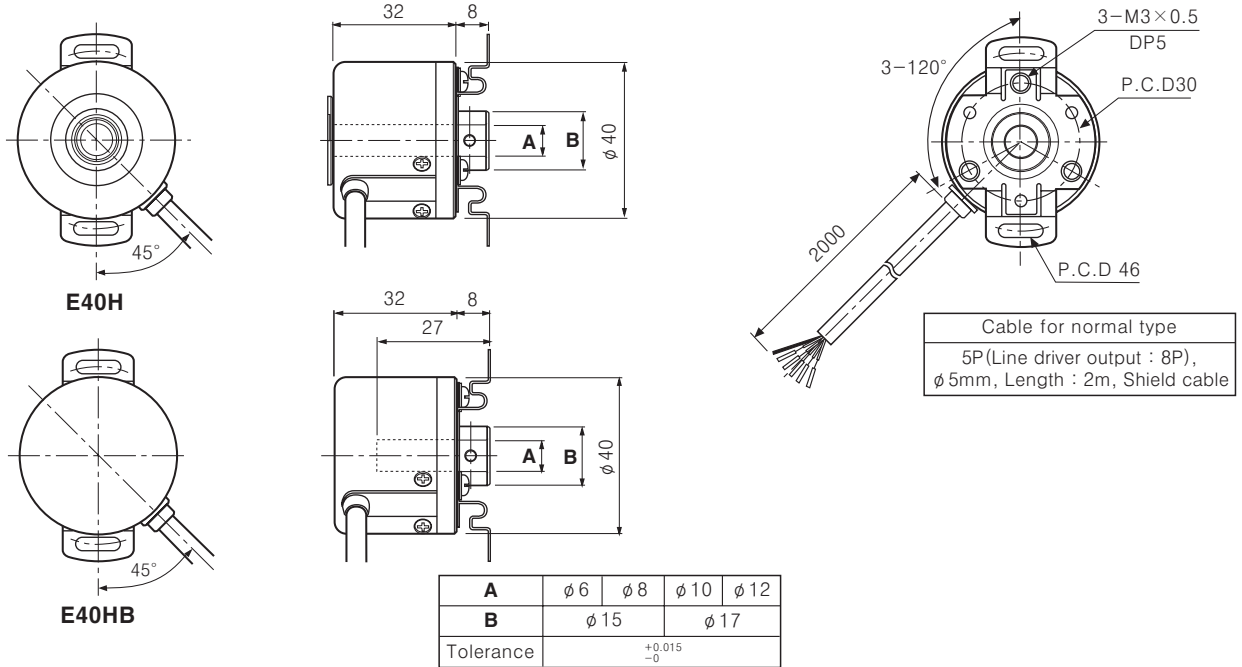

■ Cable outgoing connector type

● Connector cable (Accessory)

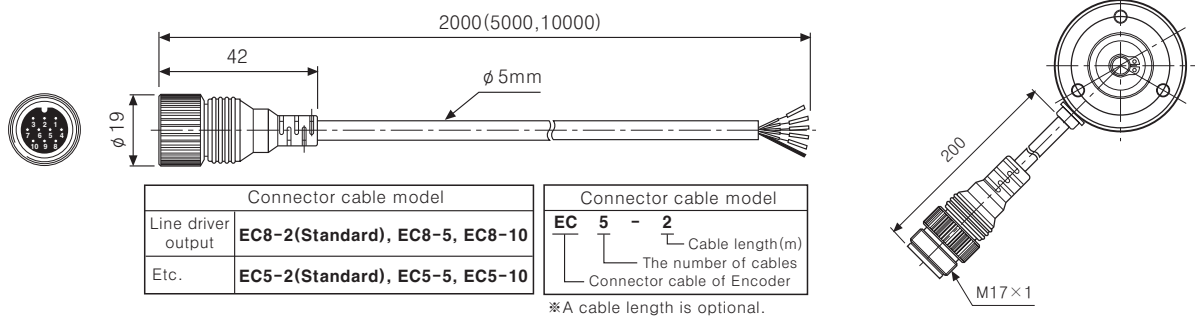

● Coupling (E40S)

[φ 6 Coupling]

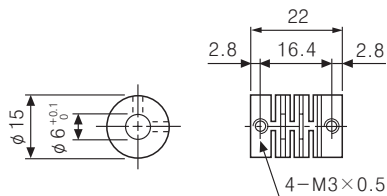

[φ 8 Coupling]

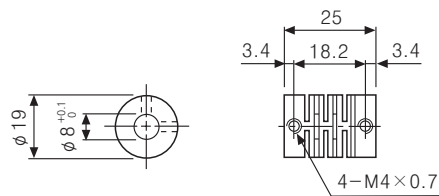

Unit: mm

(A)
Counter

(B)
Timer

(C)
Temp.
controller

(D)
Power
controller

(E)
Panel
meter

(F)
Tacho/
Speed/
Pulse
meter

(G)
Display
unit

(H)
Sensor
controller

(I)
Proximity
sensor

(J)
Photo
electric
sensor

(K)
Pressure
sensor

(L)
Rotary
encoder

(M)
5-Phase
stepping
motor &
Driver &
Controller