

# TRL

## ➤ MAIN FEATURES

- Long life and high reliability
- Strong construction for vibration and shock
- Approximately thousands for kinds are available depending on the combination of terminals, covers, contact ratings, coil etc.
- Plastic-sealed type is available
- Molded material : All UL 94V-0
- UL & cUL recognized

## ➤ APPLICATIONS

- Coil operated machines
- Vending machines
- Refrigerators
- Transportations
- Power station control equipment
- Office machines
- Building control equipment
- Medical equipment
- Amusement devices, etc.



### Option Socket :

Please refer appendix P101 · P102



- OD07-0001A (PT-08-0)
- OD07-0002A (PTF-08A)
- OD07-0003A (PTF-08AE)

## ➤ ORDERING INFORMATION

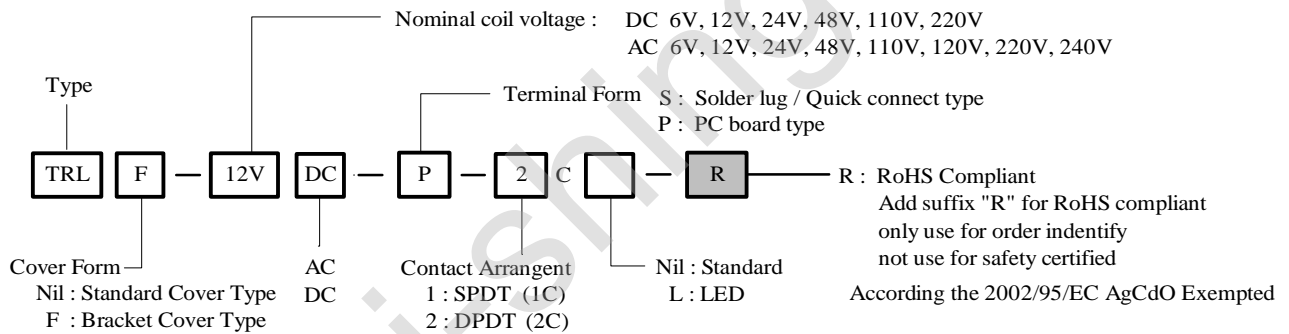

### ■ DIMENSION(unit:mm)

### ■ DRILLING(unit:mm)

### ■ WIRING DIAGRAM

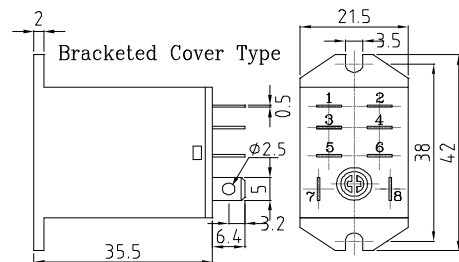
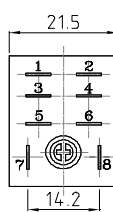
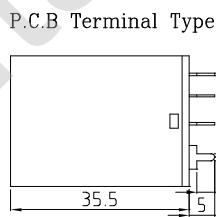
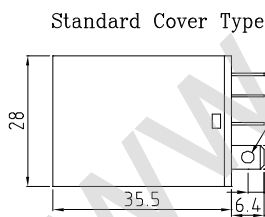

PC BOARD PATTEN (Bottom View)

SCHEMATIC (Bottom View)

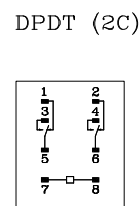
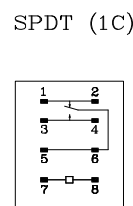
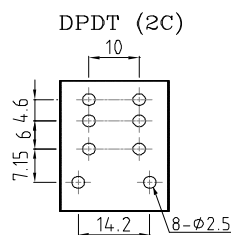
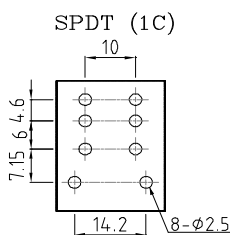

➤ **COIL DATA CHART**(at 20°C)

Nominal voltage	Pick-Up voltage	Drop-out voltage	Nominal current	Coil resistance	Power consumption	Max. allowable voltage
<b>AC Type</b>						
VAC	VAC(Max.)	VAC(Min.)	mA(+15%,-20%)	Ω (±10%)	P(VA)	(VAC)
6	4.8	1.8	183.0	11.5	Approx. 1.2VA	110% of nominal voltage
12	9.6	3.6	91.0	46		
24	19.2	7.2	46.0	184		
48	38.4	14.4	24	735		
110	88.0	33.0	11	3900		
120	96.0	36.0	9.8	4550± 15%		
220	176	66	4.2	14400± 15%		
240	192	72	5.5	15210± 15%		
<b>DC Type</b>						
VDC	VDC(Max.)	VDC(Min.)	mA(10%)	Ω (±10%)	P(W)	(VDC)
6	4.8	0.6	150	40	Approx. 0.9W	110% of nominal voltage
12	9.6	1.2	75	160		
24	19.2	2.4	37.2	650		
48	38.4	4.8	18.8	2560± 15%		
110	88	11.0	8.2	13444± 15%		
220	176	22.0	4.1	53778± 15%		

➤ **CONTACT RATING**

Arrangement	TRL -1C (SPDT)	TRL -2C(DPDT)
Item		
Rated load	15A 277VAC 15A 28VDC	10A 277VAC 10A 28VDC
Carrying current	15A	10A
Max. switching voltage	300VAC, 30VDC	
Max. switching current	15A	10A
Max. switching power	4155VA, 420W	2770VA, 280W
Min. permissible load	5VDC 100mA	
Contact material	AgCdO	

➤ **PERFORMANCE** (at initial value)

Arrangement	TRL
Item	
Contact Resistance	Max. 100mΩ
Operation time (at nominal voltage)	Max. 25msec
Release time (at nominal voltage)	Max. 25msec
Operating frequency	20 ops/minute
Insulation resistance	Min. 100MΩ (at 500VDC)
Vibration resistance	Functional : 6G 10 to 55 Hz, at double amplitude of 1mm Destructive : 12G 10 to 55 Hz, at double amplitude of 2mm
Shock resistance	Functional : Min, 20G Destructive : Min, 100G
Dielectric strength	1500VAC. for 1minute between coil and contact. 750VAC. for 1minute between contact sets. 750VAC. for 1minute between open contacts.
Ambient temperature	-40°C to +70°C
Humidity	40% to 85% RH
Life expectancy	Mechanical : 1 x 10 <sup>7</sup> operations Electrical : 2 x 10 <sup>5</sup> operations (at rated load)
Weight	abt 37grs.
UL & cUL	E156521

This datasheet for reference and subject to change without notice. Please double check final specification with Tai-Shing. (0939AA08VOL01)