

# Small Size Switching Power Supply

## DIN rail mounting type Switching Power Supply

### ■ Features

- Compact size, High quality, Cost-effective
- Universal input power
- Able to drive various controllers
- Includes overcurrent protection circuit
- DIN rail mounting and mountable without the rail



**⚠ Please read "Caution for your safety" in operation manual before using.**

### ■ Ordering information

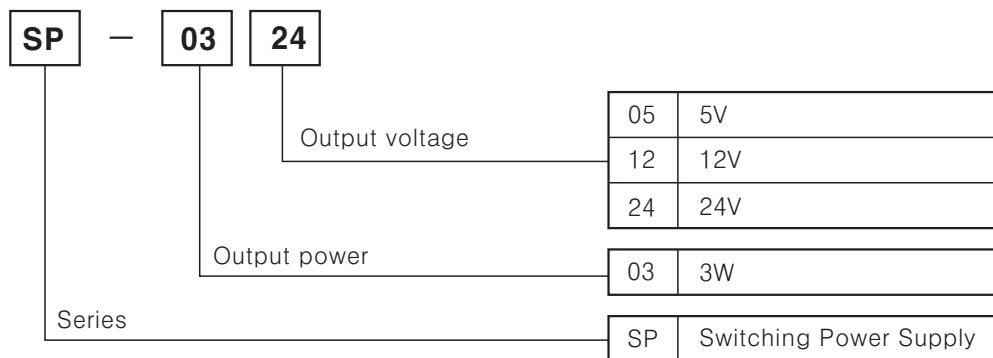

### ■ Specifications

Model		SP-0305	SP-0312	SP-0324
Capacity		3W		
Input	Power supply	100-240VAC 50/60Hz		
	Frequency	47 ~ 450Hz		
	Current consumption	Max. 0.15A		
	Efficiency	50 ~ 55%	67 ~ 74%	67 ~ 74%
Output	Voltage	5VDC	12 VDC	24VDC
	Allowable voltage range	Max. ±5%		
	Current	0.6A	0.25A	0.13A
	Ripple	Max. 2%		
	Voltage fluctuation ratio	Max. 0.5% (at 85-264VAC 100% Load)		
	Overcurrent protection	Max. 110%		
Series / Parallel operation		Not available		
Output indicator		Red LED		
Insulation resistance		100MΩ min. at 500VDC mega (Between all inputs and F.G)		
Dielectric strength		2000VAC 50/60Hz for 1 minute		
Vibration		0.75mm amplitude at frequency of 10 to 55Hz in each of X, Y, Z directions for 2 hours		
Shock		300m/s <sup>2</sup> (30G) in X, Y, Z directions for 3 times		
Ambient temperature		-10 ~ 50°C, Storage : -20 ~ 70°C		
Ambient humidity		45 ~ 85%RH		
Unit weight		Approx. 108g		

(A) Counter

(B) Timer

(C) Temp. controller

(D) Power controller

(E) Panel meter

(F) Tacho/Speed/Pulse meter

(G) Display unit

(H) Sensor controller

(I) Switching power supply

(J) Proximity sensor

(K) Photo electric sensor

(L) Pressure sensor

(M) Rotary encoder

(N) Stepping motor & Driver & Controller

(O) Graphic panel

(P) Production stoppage models & replacement

# SP Series

## Output feature data

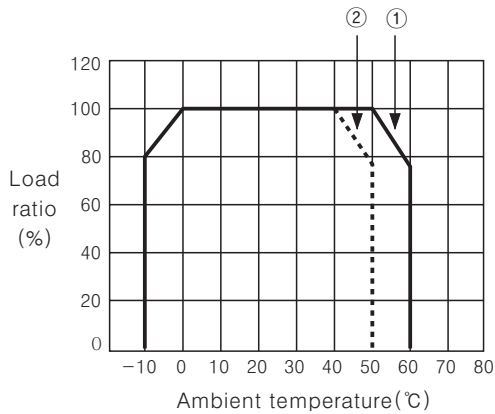

<Output feature for the ambient temperature influence >

- Please be sure when installing as the efficiency is decreased by ambient temperature.
- Please refer to output feature beside when installing as the efficiency is affected by mounting status.

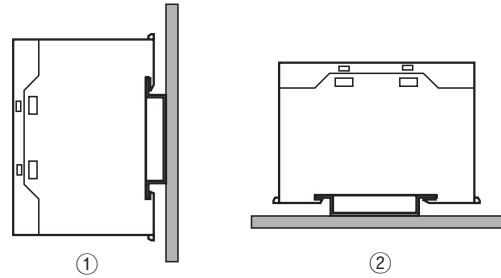

## Feature data of overcurrent protection

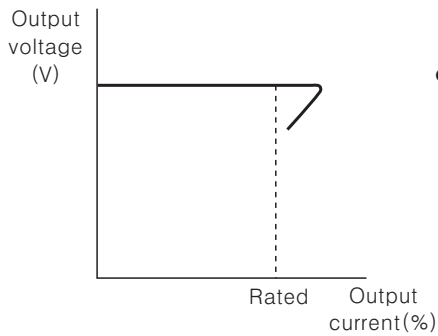

- It is able to protect overcurrent by load with built in overcurrent protection circuit. When the over rated current is flowed, the circuit is operated (Output voltage is fallen.) and it is released when the load current is under the rated current. (It is returned to the rated output voltage.)

## Block diagram

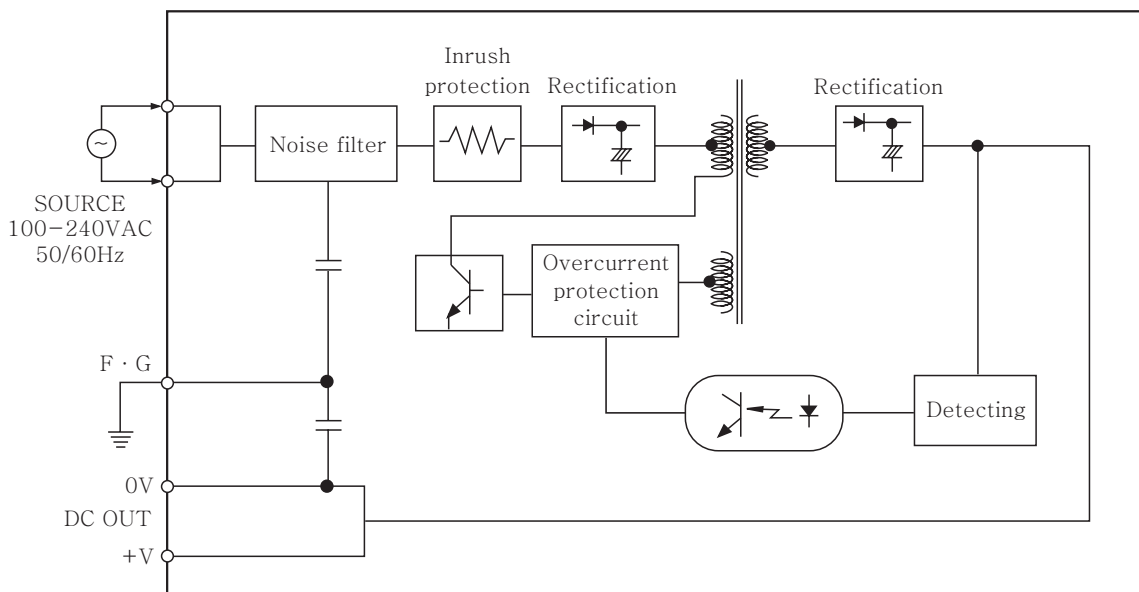

# Small Size Switching Power Supply

## ■ Dimensions

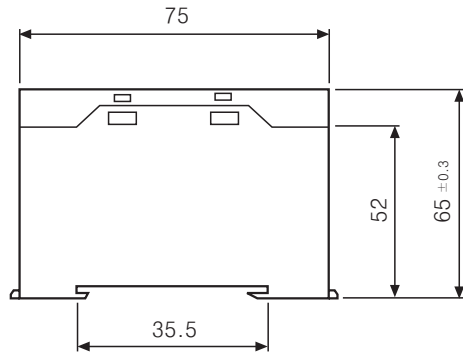
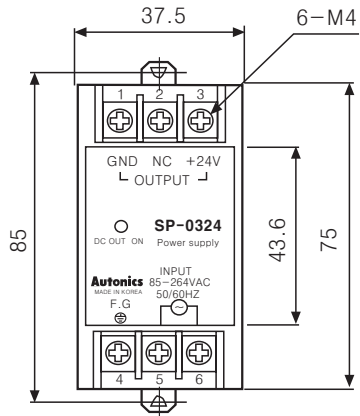

(Unit:mm)

## ■ Front part identification

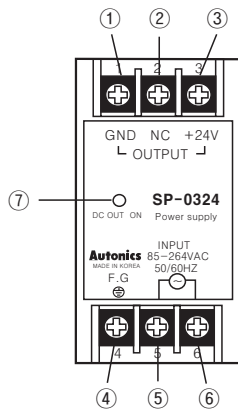

- ① GND
- ② NC terminal
- ③ +V
- ④ F · G (Field Ground) terminal
- ⑤ SOURCE
- ⑥ 100-240VAC 50/60Hz (85-264VAC)
- ⑦ Output indicator - DC output is ON, then LED ON

## ■ Rail mounting method

- To mount the power supply on the rail  
First put the power supply on the part (a) of the rail and then press it for the direction (b).

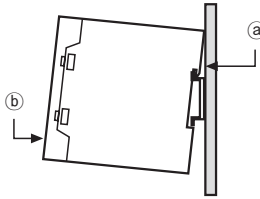

- To remove the power supply from the rail  
Firstly put a screw driver into the part (c) and push it downward.

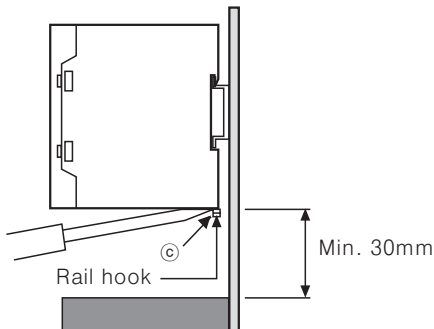

※ When mounting the power supply on the rail, place the item at least 30mm above from the floor to remove easily.

- If there is no rail, it is able to mount by screwing a bolt at the hook on the body as following figure.

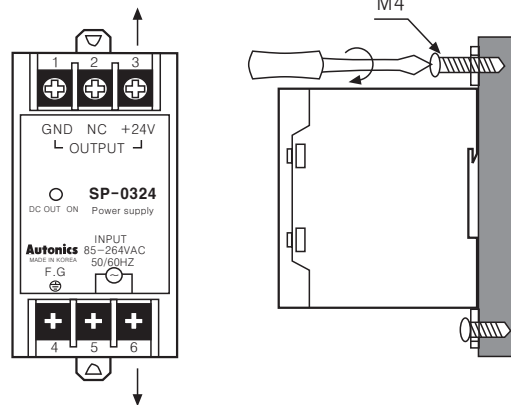

(A)	Counter
(B)	Timer
(C)	Temp. controller
(D)	Power controller
(E)	Panel meter
(F)	Tacho/Speed/Pulse meter
(G)	Display unit
(H)	Sensor controller
(I)	Switching power supply
(J)	Proximity sensor
(K)	Photo electric sensor
(L)	Pressure sensor
(M)	Rotary encoder
(N)	Stepping motor & Driver & Controller
(O)	Graphic panel
(P)	Production stoppage models & replacement

# SP Series

## ■ Proper usage

### ◎ Serial and parallel operation

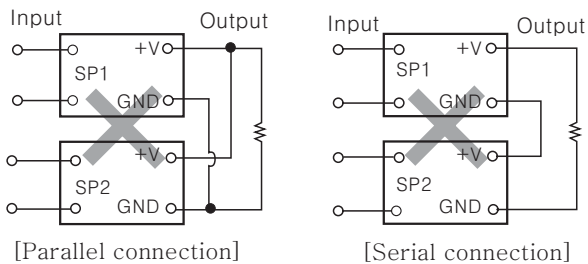

- ※ The power supply shouldn't be used in serial and parallel connection in any case. Please use it individually always.

### ◎ Caution for mounting

- Please install it at ventilating place in order to dissipate the heat effectively then it is able to improve the reliability for a long time.

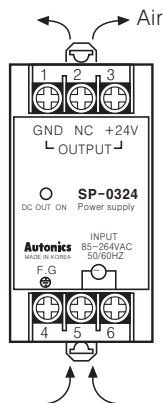

- When installing two or more power supplies side by side, please keep the interval at least 10mm so that the heat is dissipated effectively.

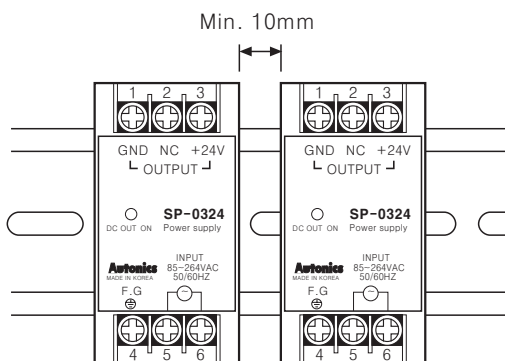

### ◎ Caution for using

- Please wire input power (AC) to the input power terminal properly. If wiring it to other terminal the inner circuit will be broken.
- It is working with 2000VAC between the terminal and case for a minute, but it will be broken if the overvoltage is supplied for several minutes
- The power supply has 100MΩ of insulation resistance between the terminal and case. Please use D.C insulation tester with 500VDC for the insulation resistance of the power supply.
- Please check as below when problem is happened.
  1. Short of DC output terminal  
(When overcurrent is supplied the overcurrent protection circuit is operated and when the load current is under the rated current it is stopped.)
  2. Wiring of AC input and DC output terminal properly.
  3. AC input voltage in rated voltage.