

TOSHIBA BIPOLAR LINEAR INTEGRATED CIRCUIT SILICON MONOLITHIC

TA8176SN, TA8176F**FM FRONT END (FOR DIGITAL TUNING SYSTEM)**

The TA8176SN, TA8176F are FM FRONT END ICs which are designed for radio cassette players and music centers. They are suitable for Digital Tuning System Applications.

FEATURES

- Improved Inter-Modulation Characteristics by Double Balanced Type Mixer Circuit.
- Built-in Current Share Type AGC Circuit for the RF Amp.
- Applicable to double-tuning in radio frequency stage.
- Built-in Local Oscillator Buffer Output Circuit for Digital Tuning System Applications.
- Excellent overload characteristics for change oscillation frequency.
- It is available to TV band. (up to 220MHz)
- Built-in IF Amp.
: $R_O = 330\Omega$ (Typ.), $V_{out} = 80mV_{rms}$ (Typ.)
- Operating Supply Voltage Range
TA8176SN : $V_{CC(opr)} = 4\sim 14V$ ($T_a = 25^\circ C$)
TA8176F : $V_{CC(opr)} = 4\sim 8V$ ($T_a = 25^\circ C$)

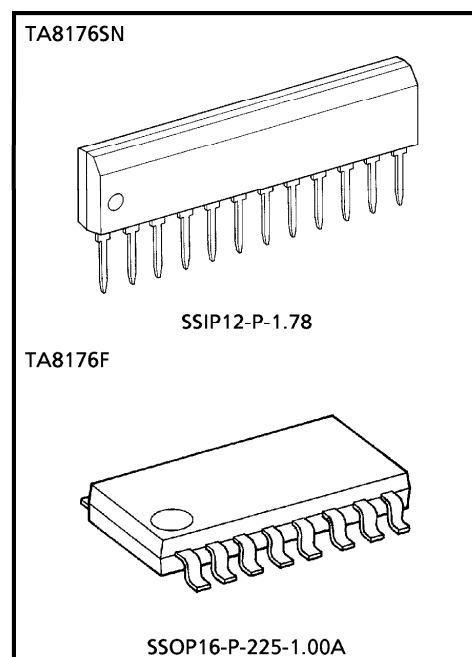

Weight
 SSIP12-P-1.78 : 0.65g (Typ.)
 SSOP16-P-225-1.00A : 0.14g (Typ.)

961001EBA2

- TOSHIBA is continually working to improve the quality and the reliability of its products. Nevertheless, semiconductor devices in general can malfunction or fail due to their inherent electrical sensitivity and vulnerability to physical stress. It is the responsibility of the buyer, when utilizing TOSHIBA products, to observe standards of safety, and to avoid situations in which a malfunction or failure of a TOSHIBA product could cause loss of human life, bodily injury or damage to property. In developing your designs, please ensure that TOSHIBA products are used within specified operating ranges as set forth in the most recent products specifications. Also, please keep in mind the precautions and conditions set forth in the TOSHIBA Semiconductor Reliability Handbook.
- The products described in this document are subject to foreign exchange and foreign trade control laws.
- The information contained herein is presented only as a guide for the applications of our products. No responsibility is assumed by TOSHIBA CORPORATION for any infringements of intellectual property or other rights of the third parties which may result from its use. No license is granted by implication or otherwise under any intellectual property or other rights of TOSHIBA CORPORATION or others.
- The information contained herein is subject to change without notice.

BLOCK DIAGRAM

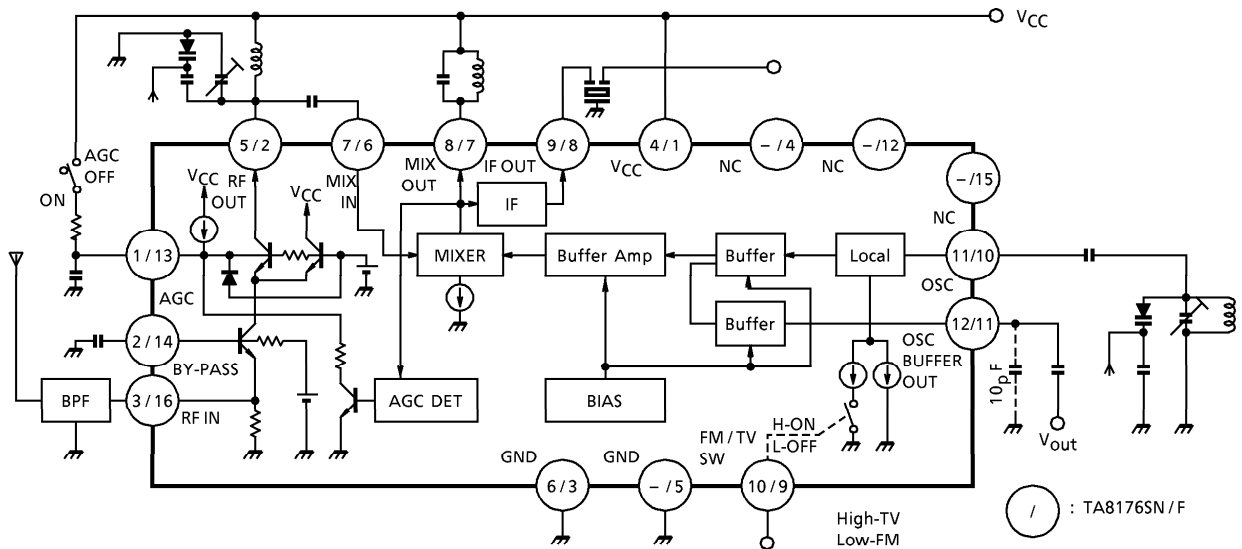

EXPLANATION OF TERMINALS (Terminal voltage shows the Typ. value at $T_a = 25^\circ\text{C}$, $V_{CC} = 5\text{V}$, AGC off,)
 FM mode, and non-signal test circuit

PIN No. (SN/F)	SYMBOL	CONTENTS	INTERNAL CIRCUIT	DC VOLTAGE (V)
1 / 13	AGC	AGC ON / OFF Switch $V_{1/13} = V_{CC} \rightarrow \text{AGC OFF}$ $V_{1/13} = \text{Open} \rightarrow \text{AGC ON}$		4.7
2 / 14	BY-PASS (RF IN)	By-pass Terminal for RF Amp Circuit. It is necessary to connect External Capacitance. (RF Amp Input Terminal. Antenna Tuning Circuit is connected)		1.46
3 / 16	RF IN (BY-PASS)	RF Amp Input Terminal. (By-pass Terminal for RF Amp Circuit. It is necessary to connect External Capacitance)		0.76
4 / 1	V_{CC}	Power Supply	—	5.0
5 / 2	RF OUT	RF Amp Output Terminal. RF Tuning Circuit is connected	Compare with Pin ① / ⑬, ② / ⑭, ③ / ⑯	5.0

PIN No. (SN/F)	SYMBOL	CONTENTS	INTERNAL CIRCUIT	DC VOLTAGE (V)
6/3, 5	GND	GND Terminal (Pin③ : GND Terminal of RF and MIX Circuit. Pin⑤ : GND Terminal of OSC Circuit. at Flat Package)	—	0
7/6	MIX IN	Mixer Input Terminal		1.86
8/7	MIX OUT	Mixer Output Terminal Mixer Coil is Connected.		5.0
9/8	IF OUT	IF Amp Output Terminal.		4.7
10/9	FM/TV SW	FM/TV Switch. At this Terminal Voltage is "H" : High OSC Voltage →TV Mode "L" : Low OSC Voltage →FM Mode		0
11/10	OSC	Local Terminal. OSC Tank Circuit is connected.		4.9
12/11	OSC BUFFER OUT	OSC BUFFER Output Terminal		4.8
- / 4	NC	—	—	—
- / 12				
- / 15				

MAXIMUM RATINGS (Ta = 25°C)

CHARACTERISTIC		SYMBOL	RATING	UNIT
Supply Voltage	TA8176SN	V _{CC}	15	V
	TA8176F		9	
Power Dissipation	TA8176SN	P _D (Note)	750	mW
	TA8176F		350	
Operating Temperature		T _{opr}	-25~75	°C
Storage Temperature		T _{stg}	-55~150	°C

(Note) Derated above Ta = 25°C in the proportion of 6mW/°C for TA8176SN and of 2.8mW/°C for TA8176F.

ELECTRICAL CHARACTERISTICS (Unless otherwise specified, V_{CC} = 5V, Ta = 25°C, f = 98MHz, fm = 1kHz, Δf = ±22.5kHz, SW1 = ON, SW2 = OFF)

CHARACTERISTIC	SYMBOL	TEST CIRCUIT	TEST CONDITION	MIN.	TYP.	MAX.	UNIT
Supply Current	I _{CC1}	1	V _{in} = 0	—	16.5	22	mA
	I _{CC2}	2	V _{in} = 0	—	17.0	22.5	
Conversion Gain	G _{C1}	1	f _{in} = 98MHz V _{in} = 50dBμV EMF G _{C1} = 20log ₁₀ $\frac{V_{out}}{V_{in}}$	37	41	—	dB
	G _{C2}	2	f _{in} = 180MHz V _{in} = 55dBμV EMF G _{C2} = 20log ₁₀ $\frac{V_{out}}{V_{in}}$	36	40	—	
Local OSC Voltage	V _{osc1}	3	f _{OSC} = 108.7MHz	—	275	—	mV _{rms}
	V _{osc2}	3	f _{OSC} = 190.7MHz SW2 = ON	—	150	—	
Local OSC Buffer output Voltage	V _o (osc1)	3	f _{OSC} = 108.7MHz	45	80	—	mV _{rms}
	V _o (osc2)	3	f _{OSC} = 190.7MHz SW2 = ON	—	80	—	
IF Amp. Output Voltage	V _{out1}	1	f _{in} = 98MHz V _{in} = 80dBμV EMF	—	130	—	mV _{rms}
	V _{out2}	2	f _{in} = 98MHz V _{in} = 80dBμV EMF	—	130	—	
Local OSC Stop Voltage	V _{stop1}	3	f _{OSC} = 108.7MHz	—	2.5	2.8	V
	V _{stop2}	3	f _{OSC} = 190.7MHz SW2 = ON	—	2.7	3.0	

CHARACTERISTIC		SYMBOL	TEST CIR-CUIT	TEST CONDITION	MIN.	TYP.	MAX.	UNIT
Pin③ / ⑬ Impedance	Parallel Input Resistance	$r_{ip3/16}$	4	f = 98MHz	—	42	—	Ω
	Parallel Input Capacitance	$c_{ip3/16}$	4		—	- 12	—	pF
Pin⑤ / ② Impedance	Parallel Output Resistance	$r_{op5/2}$	4		—	10	—	k Ω
	Parallel Output Capacitance	$c_{op5/2}$	4		—	7.3	—	pF
Pin⑦ / ⑥ Impedance	Parallel Input Resistance	$r_{ip7/6}$	4		—	2.7	—	k Ω
	Parallel Input Capacitance	$c_{ip7/6}$	4		—	6.7	—	pF
Pin⑧ / ⑦ Impedance	Parallel Output Resistance	$r_{op8/7}$	4	f = 10.7MHz	—	39	—	k Ω
	Parallel Output Capacitance	$c_{op8/7}$	4		—	6.7	—	pF
Pin⑫ / ⑪ Impedance	Parallel Output Resistance	$r_{op12/11}$	4	f = 108MHz	—	95	—	Ω
	Parallel Output Capacitance	$c_{op12/11}$	4		—	1.4	—	pF

TEST CIRCUIT 1

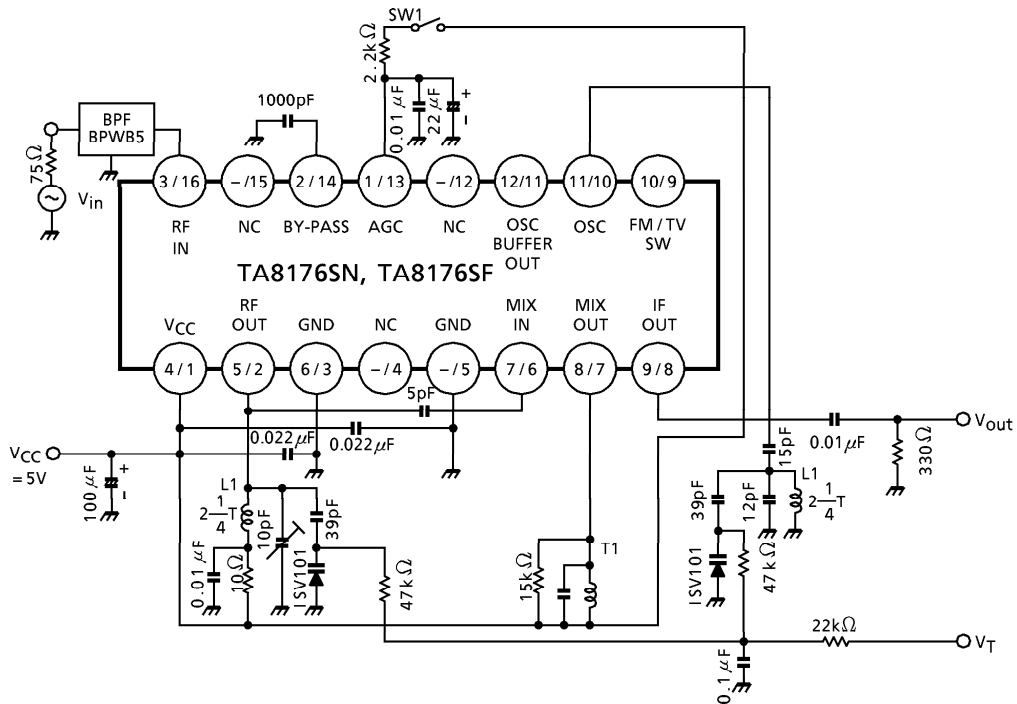

TEST CIRCUIT 2

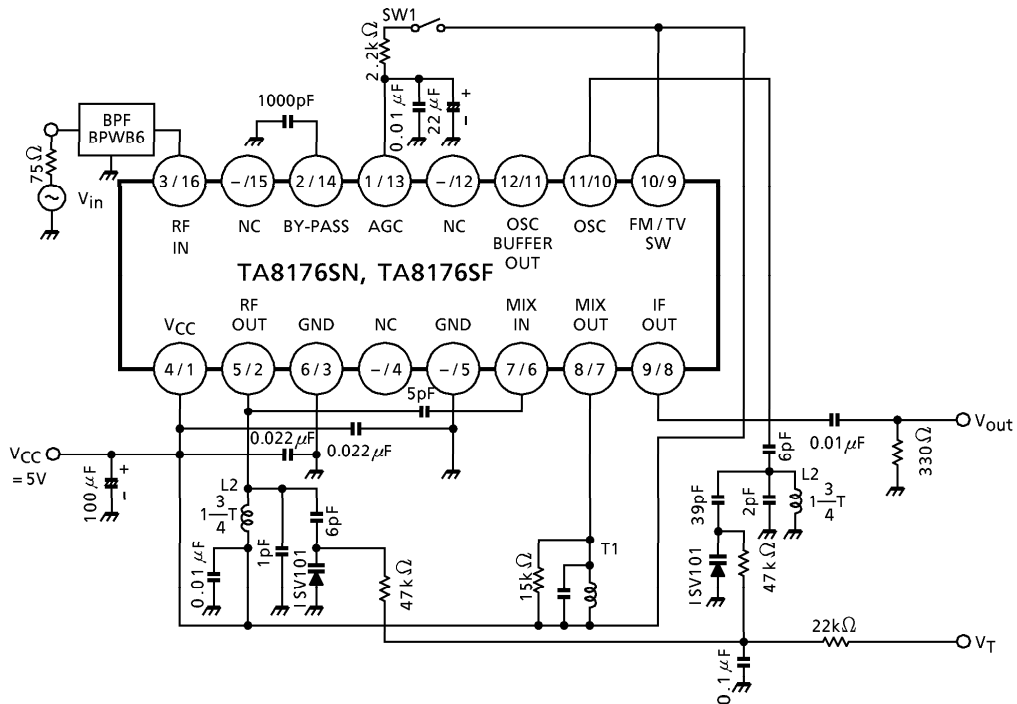

TEST CIRCUIT 3

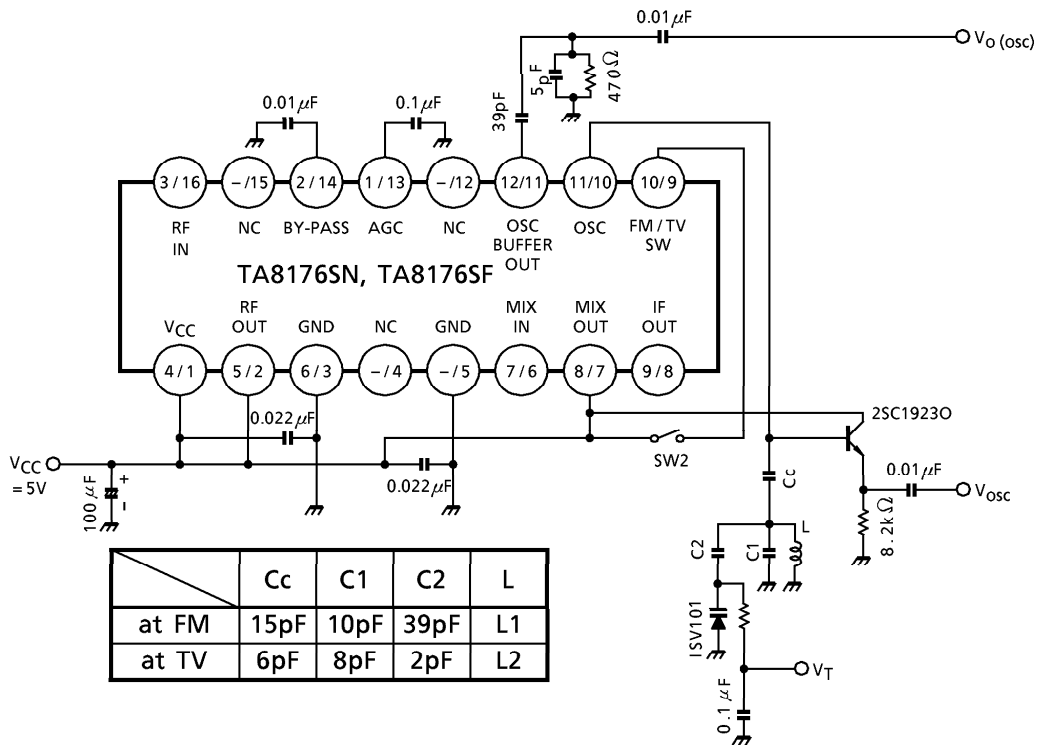

COIL DATA

COIL No.	STAGE	TEST FREQ	L (μH)	C ₀ (pF)	Q ₀	TURNS				WIRE (mm)	REMARKS
						①-②	②-③	①-③	④-⑥		
L1	FM RF / OSC	100MHz	0.06		100		2 $\frac{1}{4}$			φ 0.5 UEW	Within Core
L2	TV RF / OSC	100MHz	0.045		100		1 $\frac{3}{4}$			φ 0.5 UEW	Within Core
T1	FM IFT	10.7MHz		75	100			13	2	φ 0.16 UEW	SUMIDA 2153-414-041A

L1, L2

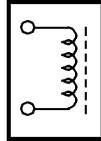

T1

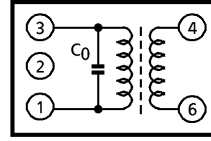

TEST CIRCUIT 4

Pin③ / ⑬ input impedance

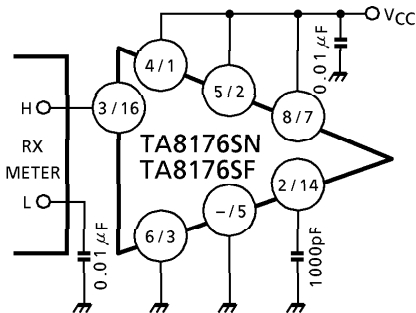

Pin⑤ / ② output impedance

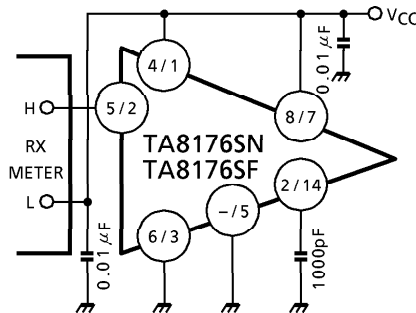

Pin⑦ / ⑥ input impedance

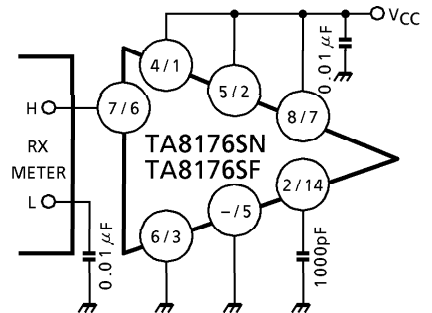

Pin⑧ / ⑦ output impedance

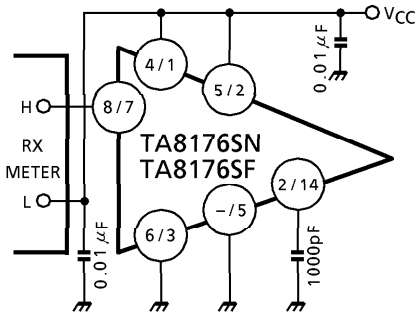

Pin⑩ / ⑪ output impedance

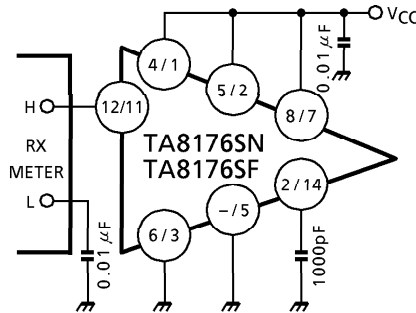

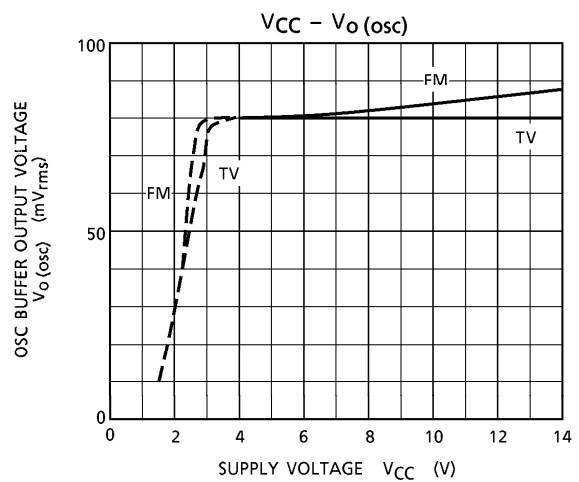
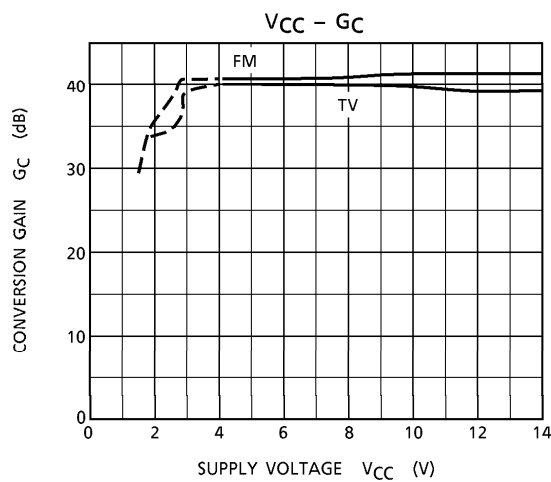
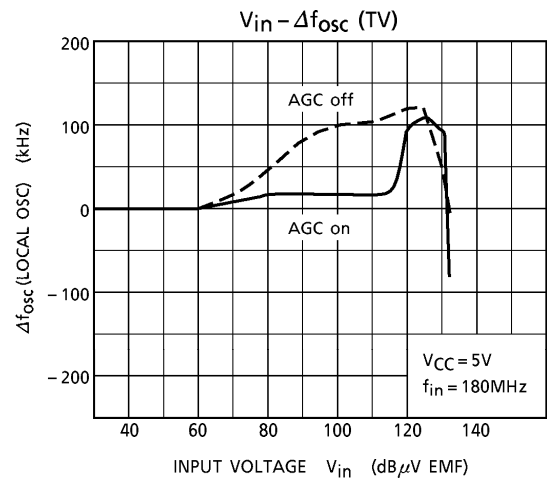
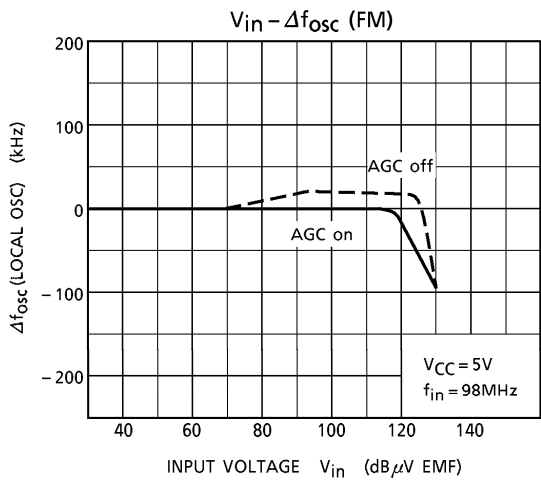
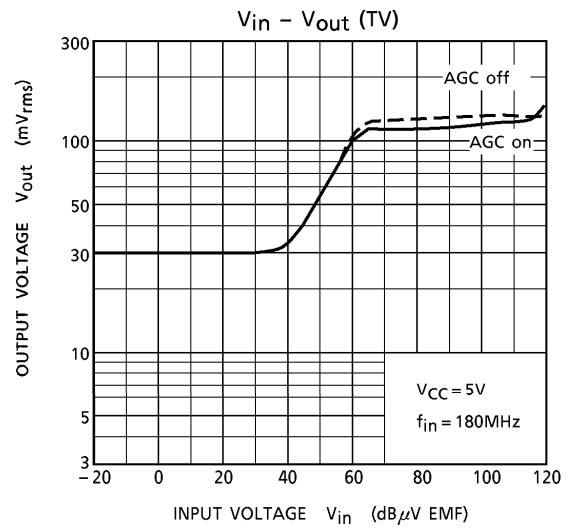
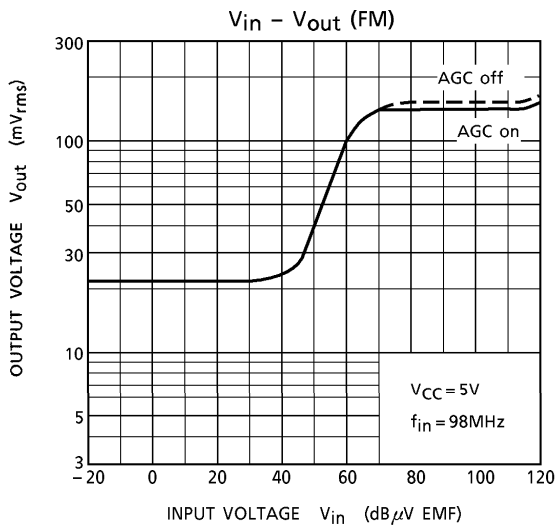

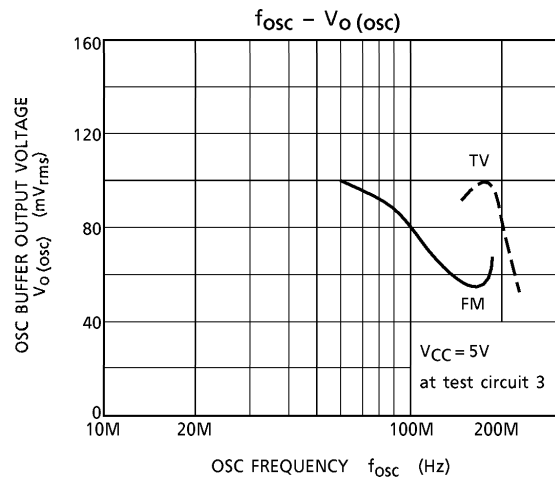
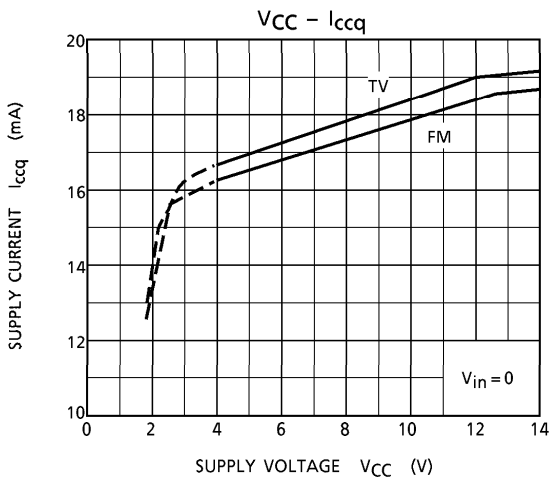
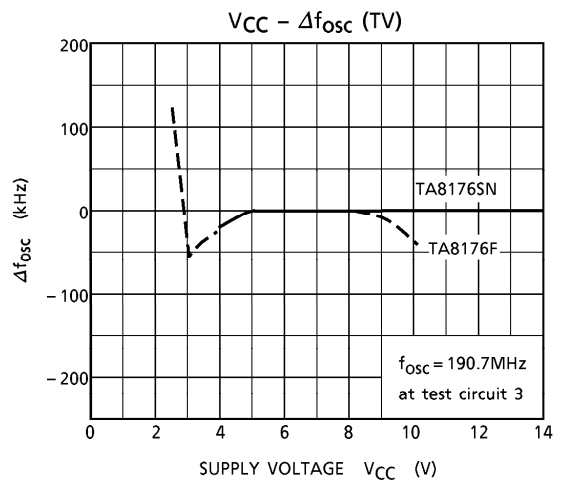
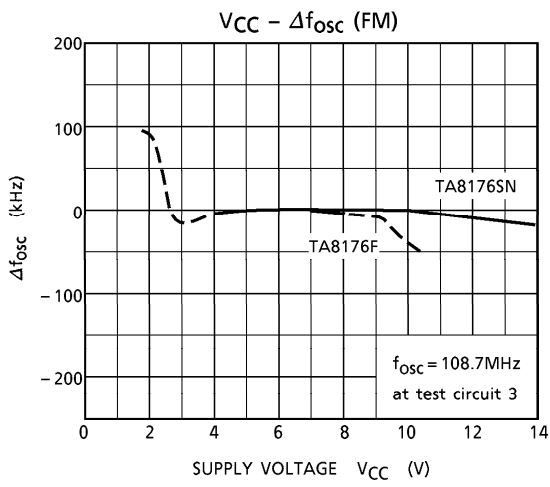

OUTLINE DRAWING
SSIP12-P-1.78

Unit : mm

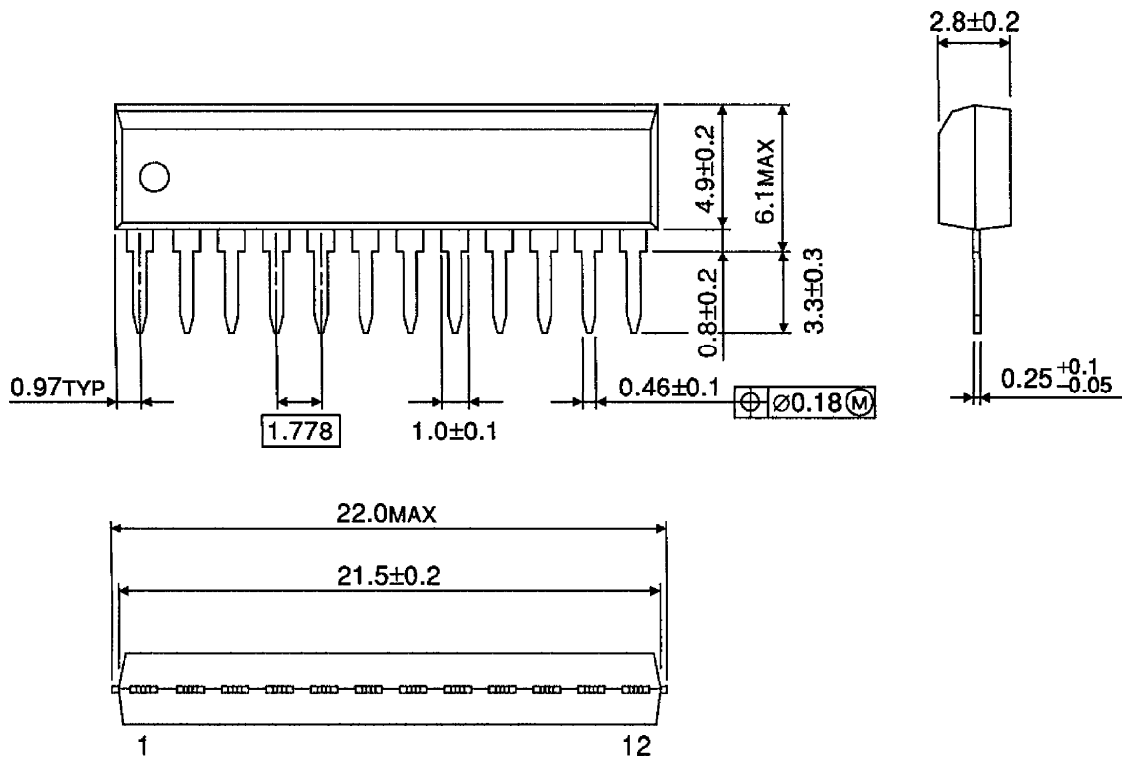

Weight : 0.65g (Typ.)

OUTLINE DRAWING
SSOP16-P-225-1.00A

Unit : mm

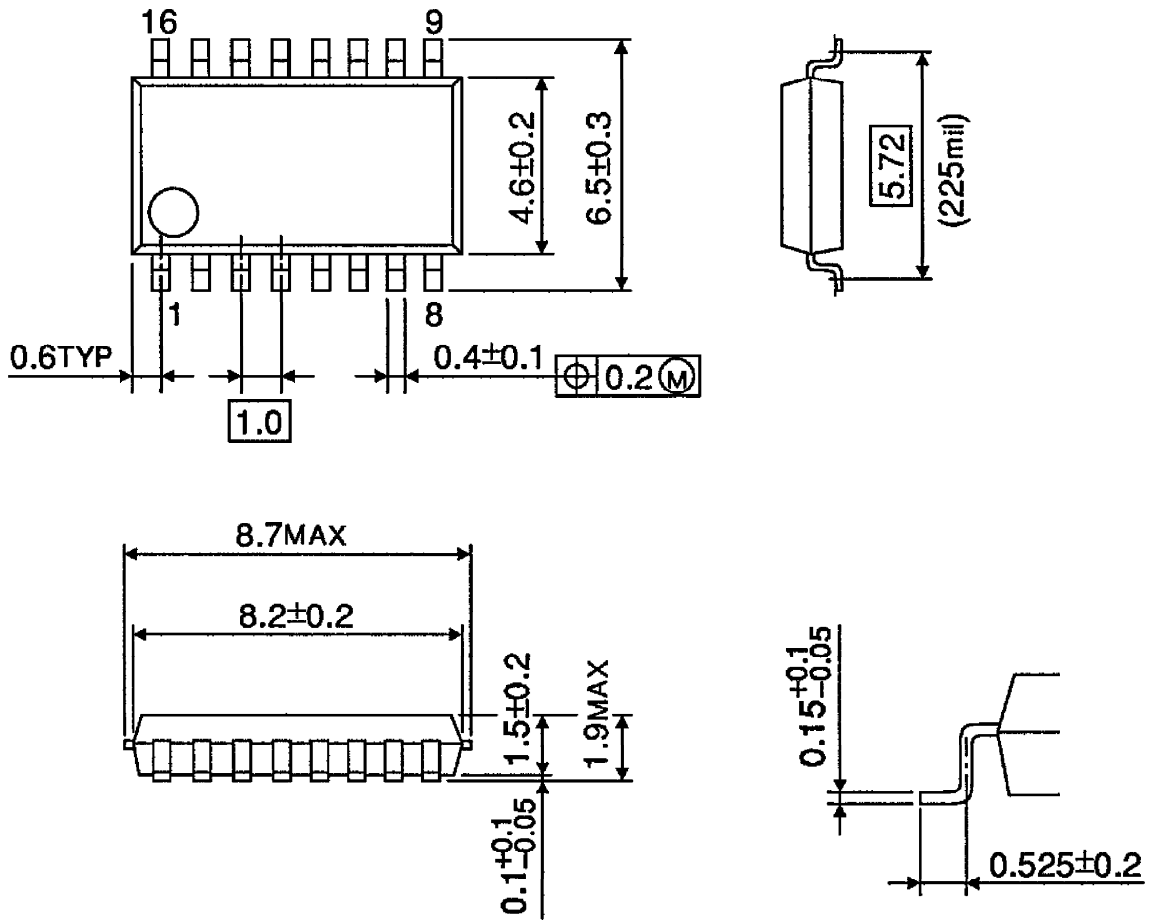

Weight : 0.14g (Typ.)