

### Smart Lowside Power Switch

#### Features

- Logic Level Input
- Input Protection (ESD)
- Thermal Shutdown
- Overload protection
- Short circuit protection
- Overvoltage protection
- Current limitation
- Maximum current adjustable with external resistor
- Current sense
- Status feedback with external input resistor
- Analog driving possible

#### Product Summary

Drain source voltage	$V_{DS}$	60	V
On-state resistance	$R_{DS(on)}$	100	mΩ
Current limit	$I_{D(lim)}$	1.5	A
Nominal load current	$I_{D(ISO)}$	3.5	A
Clamping energy	$E_{AS}$	1000	mJ

#### Application

- All kinds of resistive, inductive and capacitive loads in switching or linear applications
- μC compatible power switch for 12 V and 24 V DC applications
- Replaces electromechanical relays and discrete circuits

#### General Description

N channel vertical power FET in Smart SIPMOS® chip on chip technology. Fully protected by embedded protected functions.

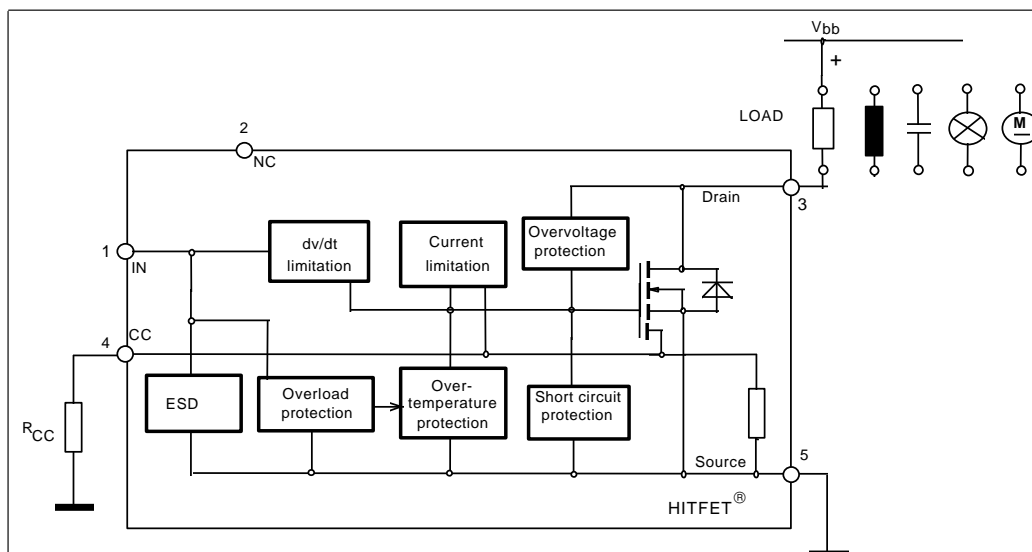
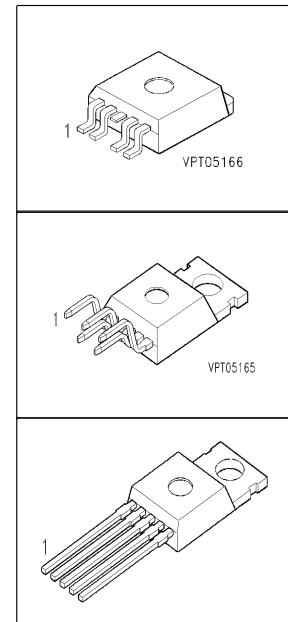

### Maximum Ratings at T<sub>j</sub> = 25 °C unless otherwise specified

Parameter	Symbol	Value	Unit
Drain source voltage	V <sub>DS</sub>	60	V
Drain source voltage for short circuit protection R <sub>CC</sub> = 0 Ω without R <sub>CC</sub>	V <sub>DS(SC)</sub>	15 50	
Continuous input current <sup>1)</sup> -0.2V ≤ V <sub>IN</sub> ≤ 10V V <sub>IN</sub> < -0.2V or V <sub>IN</sub> > 10V	I <sub>IN</sub>	no limit   I <sub>IN</sub>   ≤ 2	mA
Operating temperature	T <sub>j</sub>	- 40 ... +150	°C
Storage temperature	T <sub>stg</sub>	- 55 ... +150	
Power dissipation T <sub>C</sub> = 25 °C	P <sub>tot</sub>	50	W
Unclamped single pulse inductive energy I <sub>D(ISO)</sub> = 3.5 A	E <sub>AS</sub>	1000	mJ
<b>Electrostatic discharge voltage</b> (Human Body Model) according to MIL STD 883D, method 3015.7 and EOS/ESD assn. standard S5.1 - 1993	V <sub>ESD</sub>	3000	V
Load dump protection V <sub>LoadDump</sub> <sup>2)</sup> = V <sub>A</sub> + V <sub>S</sub> V <sub>IN</sub> =low or high; V <sub>A</sub> =13.5 V t <sub>d</sub> = 400 ms, R <sub>I</sub> = 2 Ω, I <sub>D</sub> =0,5*3.5A t <sub>d</sub> = 400 ms, R <sub>I</sub> = 2 Ω, I <sub>D</sub> = 3.5A	V <sub>LD</sub>	75 70	
DIN humidity category, DIN 40 040		E	
IEC climatic category; DIN IEC 68-1		40/150/56	

### Thermal resistance

junction - case:	R <sub>thJC</sub>	2.5	K/W
junction - ambient:	R <sub>thJA</sub>	75	
SMD version, device on PCB: <sup>3)</sup>	R <sub>thJA</sub>	45	

<sup>1</sup>A sensor holding current of 500 μA has to be guaranteed in the case of thermal shutdown (see also page 3)

<sup>2</sup>V<sub>LoadDump</sub> is setup without the DUT connected to the generator per ISO 7637-1 and DIN 40839

<sup>3</sup>Device on 50mm\*50mm\*1.5mm epoxy PCB FR4 with 6cm<sup>2</sup> (one layer, 70 μm thick) copper area for Drain connection. PCB is vertical without blown air.

**Electrical Characteristics**

Parameter at $T_j=25^\circ\text{C}$ , unless otherwise specified	Symbol	Values			Unit
		min.	typ.	max.	
<b>Characteristics</b>					
Drain source clamp voltage $T_j = -40 \dots +150^\circ\text{C}$ , $I_D = 10 \text{ mA}$	$V_{DS(AZ)}$	60	-	73	V
Off state drain current $V_{DS} = 32 \text{ V}$ , $T_j = -40\dots+150^\circ\text{C}$ , $V_{IN} = 0 \text{ V}$	$I_{DSS}$	-	-	5	$\mu\text{A}$
Input threshold voltage $I_D = 0,7 \text{ mA}$	$V_{IN(th)}$	1.3	1.7	2.2	V
Input current - normal operation, $I_D < I_{D(lim)}$ : $V_{IN} = 10 \text{ V}$	$I_{IN(1)}$	-	30	60	$\mu\text{A}$
Input current - current limitation mode, $I_D = I_{D(lim)}$ : $V_{IN} = 10 \text{ V}$	$I_{IN(2)}$	-	120	300	
Input current - after thermal shutdown, $I_D = 0 \text{ A}$ : $V_{IN} = 10 \text{ V}$	$I_{IN(3)}$	-	2200	4000	
Input holding current after thermal shutdown $T_j = 25^\circ\text{C}$ $T_j = 150^\circ\text{C}$	$I_{IN(H)}$	500 300	- -	- -	
On-state resistance $I_D = 3.5 \text{ A}$ , $V_{IN} = 5 \text{ V}$ , $T_j = 25^\circ\text{C}$ $I_D = 3.5 \text{ A}$ , $V_{IN} = 5 \text{ V}$ , $T_j = 150^\circ\text{C}$	$R_{DS(on)}$	- -	90 180	120 240	$\text{m}\Omega$
On-state resistance $I_D = 3.5 \text{ A}$ , $V_{IN} = 10 \text{ V}$ , $T_j = 25^\circ\text{C}$ $I_D = 3.5 \text{ A}$ , $V_{IN} = 10 \text{ V}$ , $T_j = 150^\circ\text{C}$	$R_{DS(on)}$	- -	80 160	100 200	
Nominal load current (ISO 10483) $V_{IN} = 10 \text{ V}$ , $V_{DS} = 0.5 \text{ V}$ , $T_C = 85^\circ\text{C}$	$I_{D(ISO)}$	3.5	-	-	A

### Electrical Characteristics

Parameter at $T_j=25^\circ\text{C}$ , unless otherwise specified	Symbol	Values			Unit
		min.	typ.	max.	

### Characteristics

Initial peak short circuit current limit $V_{IN} = 10\text{ V}$ , $V_{DS} = 12\text{ V}$	$I_{D(SCP)}$	-	80	-	A
Current limit <sup>1)</sup> $V_{IN} = 10\text{ V}$ , $V_{DS} = 12\text{ V}$ , $t_m = 350\text{ }\mu\text{s}$ , $T_j = -40\dots+150\text{ }^\circ\text{C}$ , without $R_{CC}$ $V_{IN} = 10\text{ V}$ , $V_{DS} = 12\text{ V}$ , $t_m = 350\text{ }\mu\text{s}$ , $T_j = -40\dots+150\text{ }^\circ\text{C}$ , $R_{CC} = 0\text{ }\Omega$	$I_{D(lim)}$	1.5 35	2.5 45	6 55	

### Dynamic Characteristics

Turn-on time $V_{IN}$ to 90% $I_D$ : $R_L = 4,7\text{ }\Omega$ , $V_{IN} = 0$ to $10\text{ V}$ , $V_{bb} = 12\text{ V}$	$t_{on}$	-	40	70	$\mu\text{s}$
Turn-off time $V_{IN}$ to 10% $I_D$ : $R_L = 4,7\text{ }\Omega$ , $V_{IN} = 10$ to $0\text{ V}$ , $V_{bb} = 12\text{ V}$	$t_{off}$	-	70	150	
Slew rate on 70 to 50% $V_{bb}$ : $R_L = 4,7\text{ }\Omega$ , $V_{IN} = 0$ to $10\text{ V}$ , $V_{bb} = 12\text{ V}$	$-dV_{DS}/dt_{on}$	-	1	3	$\text{V}/\mu\text{s}$
Slew rate off 50 to 70% $V_{bb}$ : $R_L = 4,7\text{ }\Omega$ , $V_{IN} = 10$ to $0\text{ V}$ , $V_{bb} = 12\text{ V}$	$dV_{DS}/dt_{off}$	-	1	3	

### Protection Functions

Thermal overload trip temperature	$T_{jt}$	150	165	-	$^\circ\text{C}$
Unclamped single pulse inductive energy $I_D = 3.5\text{ A}$ , $T_j = 25\text{ }^\circ\text{C}$ , $V_{bb} = 32\text{ V}$ $I_D = 3.5\text{ A}$ , $T_j = 150\text{ }^\circ\text{C}$ , $V_{bb} = 32\text{ V}$	$E_{AS}$	1000 225	- -	- -	mJ

### Inverse Diode

Inverse diode forward voltage $I_F = 5 \cdot 3.5\text{ A}$ , $t_m = 300\text{ }\mu\text{s}$ , $V_{IN} = 0\text{ V}$	$V_{SD}$	-	1	-	V
--	----------	---	---	---	---

<sup>1)</sup> Device switched on into existing short circuit (see diagram Determination of  $I_{D(lim)}$ ). Dependant on the application, these values might be exceeded for max. 50  $\mu\text{s}$  in case of short circuit occurs while the device is on condition

## Block Diagramm

### Terms

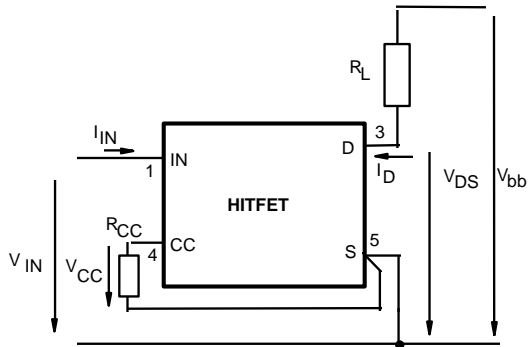

The ground lead impedance of  $R_{CC}$  should be as low as possible

### Input circuit (ESD protection)

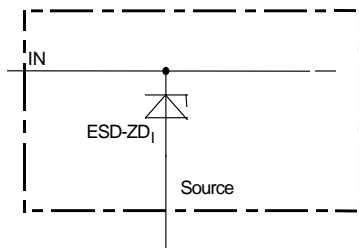

ESD zener diodes are not designed for DC current  $> 2 \text{ mA}$  @  $V_{IN} > 10 \text{ V}$ .

### Inductive and overvoltage output clamp

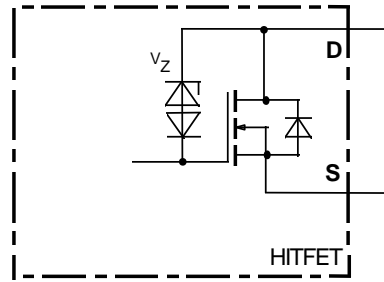

### Short circuit behaviour

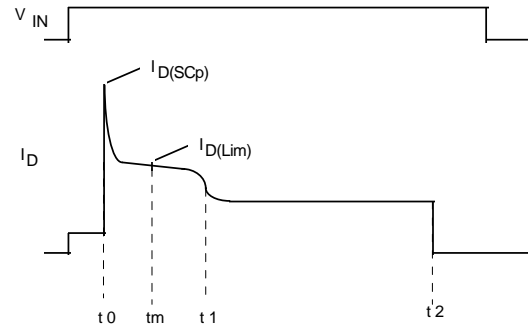

- $t_0$ : Turn on into a short circuit
- $t_m$ : Measurementpoint for  $I_{D(Lim)}$
- $t_1$ : Activation of the fast temperature sensor and regulation of the drain current to a level wher the junction temperature remains constant.
- $t_2$ : Thermal shutdown caused by the second temperature sensor, achieved by an integrating measurement.

### Maximum allowable power dissipation

$$P_{\text{tot}} = f(T_c)$$

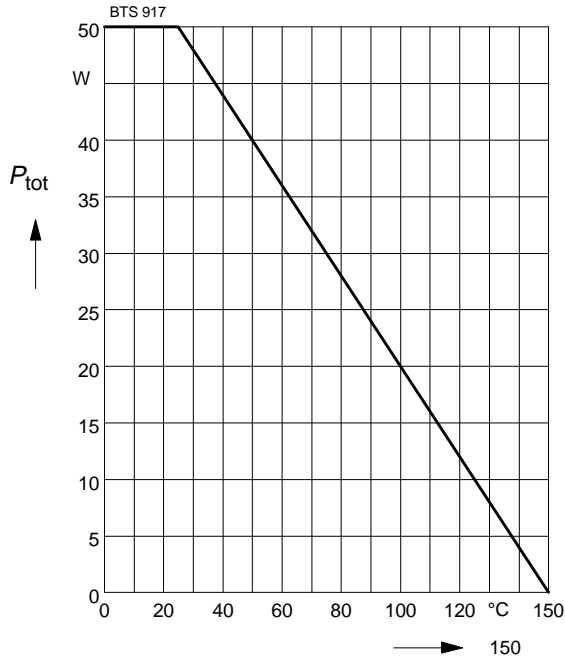

### On-state resistance

$$R_{\text{ON}} = f(T_j); I_D=3.5\text{A}; V_{\text{IN}}=10\text{V}$$

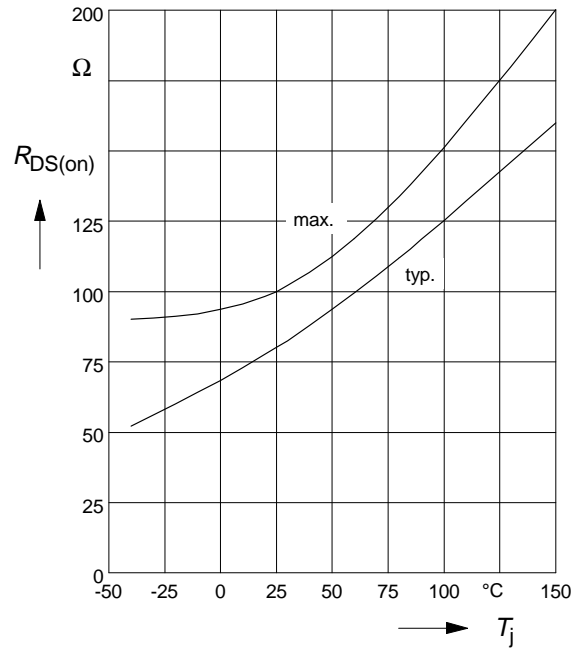

### On-state resistance

$$R_{\text{ON}} = f(T_j); I_D=3.5\text{A}; V_{\text{IN}}=5\text{V}$$

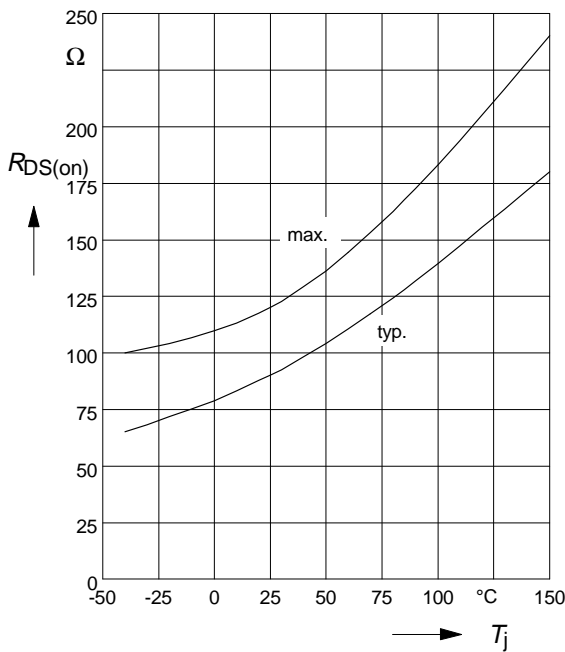

### Typ. input threshold voltage

$$V_{\text{IN(th)}} = f(T_j); I_D=0.7\text{A}; V_{\text{DS}}=12\text{V}$$

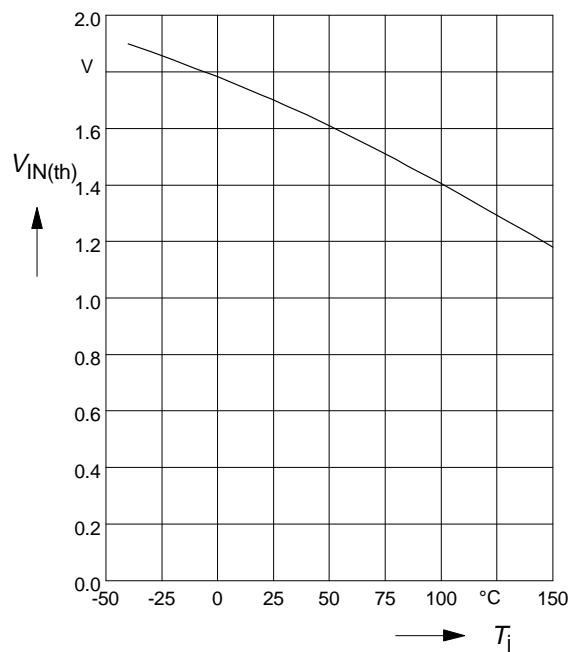

### Typ. transfer characteristics

$$I_D = f(V_{IN}); V_{DS}=12V; T_j=25^\circ C$$

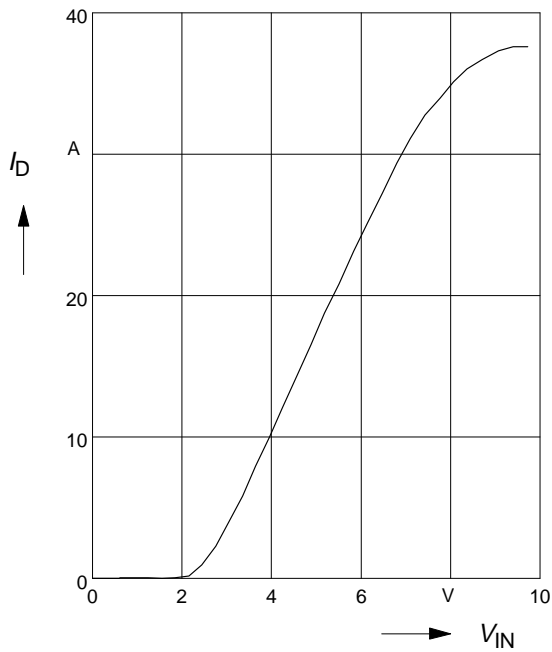

### Typ. short circuit current

$$I_{Dlim} = f(T_j); R_{CC}=0\Omega, V_{DS}=12V$$

Parameter:  $V_{IN}$

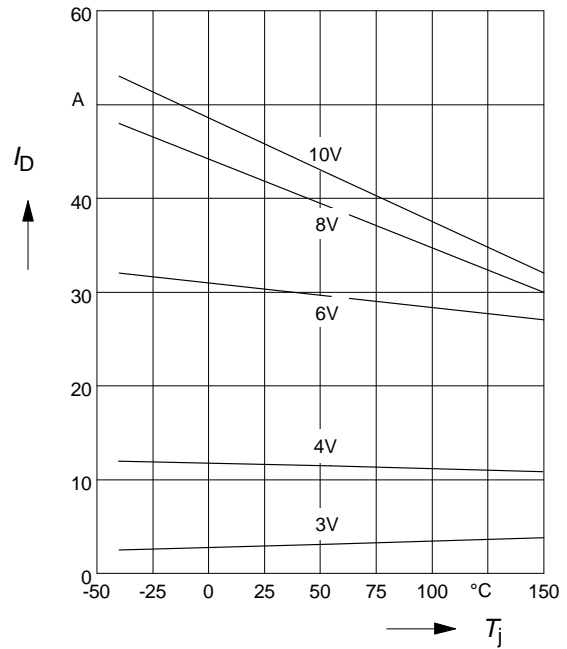

### Typ. output characteristic

$$I_D = f(V_{DS}); T_j=25^\circ C$$

Parameter:  $V_{IN}$

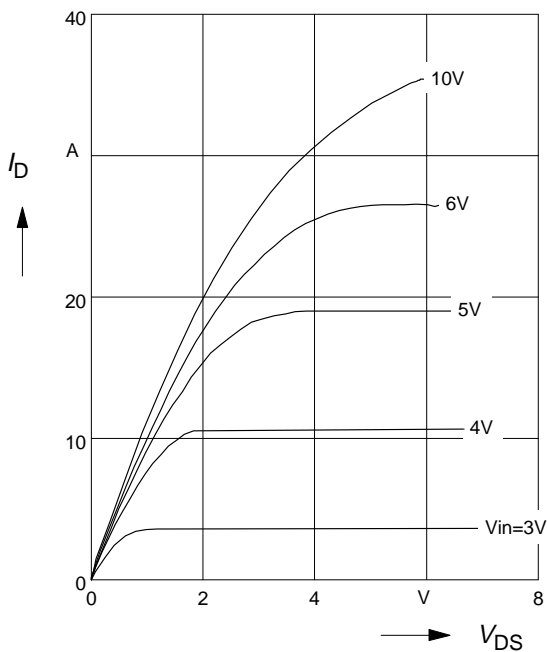

### Safe Operating Area

$$I_{D(SC)} = f(V_{DS}); T_j=25^\circ C$$

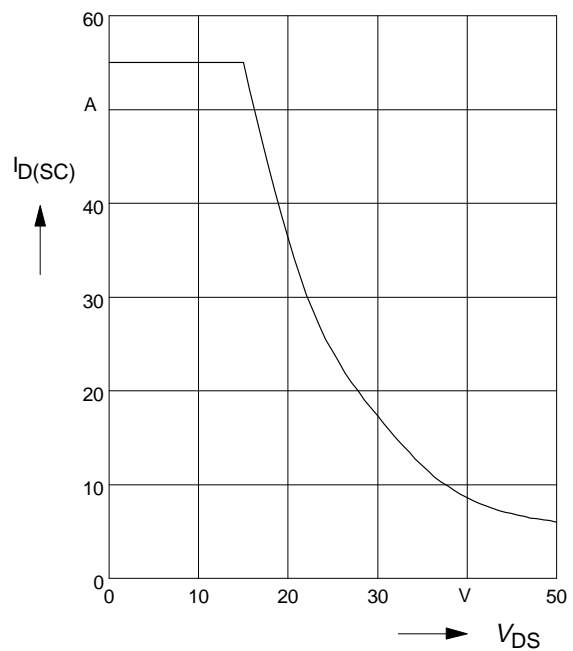

### Typ. current limit versus $R_{CC}$

$$I_{D(lim)} = f(R_{CC}); T_j = 25^\circ\text{C}$$

Parameter:  $V_{IN}$

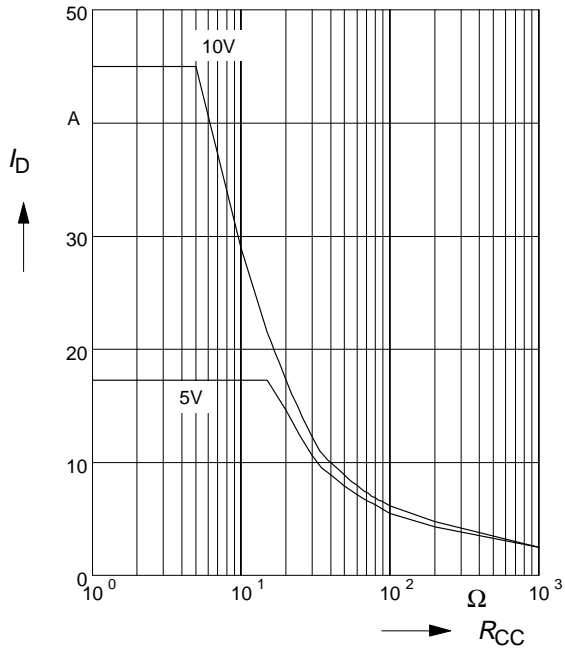

### Typ. current sense characteristics

$$V_{CC} = f(I_D); V_{IN} = 10\text{V}$$

Parameter:  $R_{CC}, T_j$

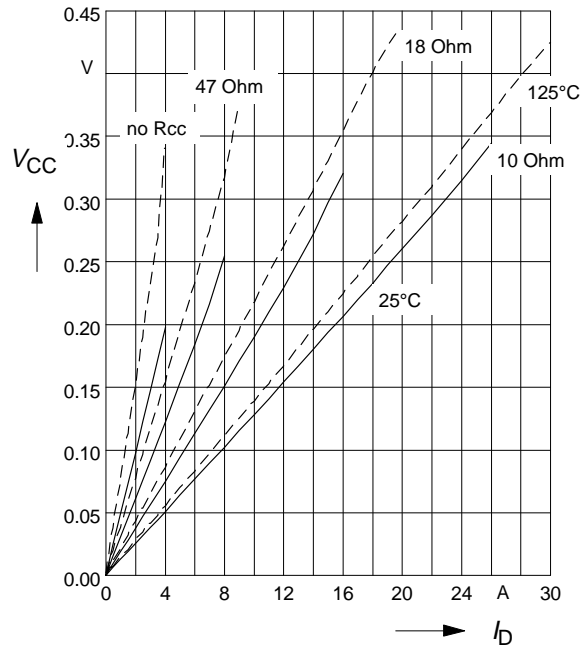

### Transient thermal impedance

$$Z_{thJC} = f(t_p)$$

Parameter:  $D = t_p / T$

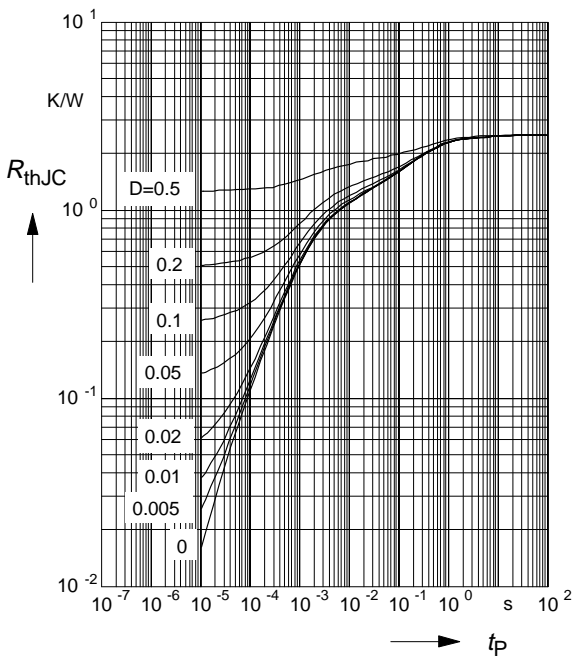



**Application examples:**

**Current Sense Features and Status Signals**

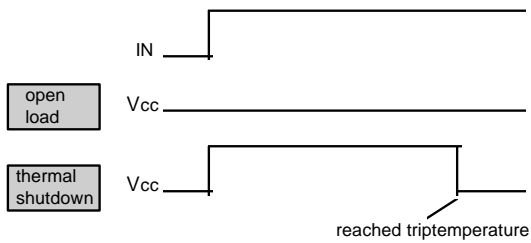
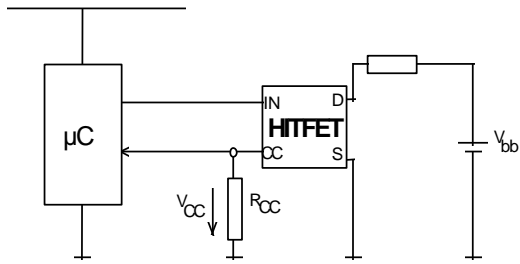

The accuracy of Vcc is at each temperature about  $\pm 10\%$

**Status signal of thermal shutdown by monitoring input current**

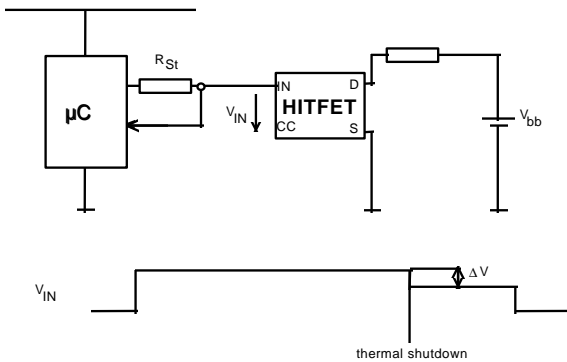

$$\Delta V = R_{ST} * I_{IN(3)}$$

## Package and ordering code all dimensions in mm

Ordering code: Q67060-S6700-A4

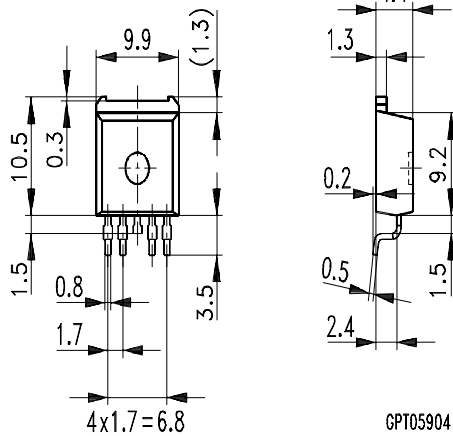

GPT05904

Ordering Code: Q67060-S6700-A2

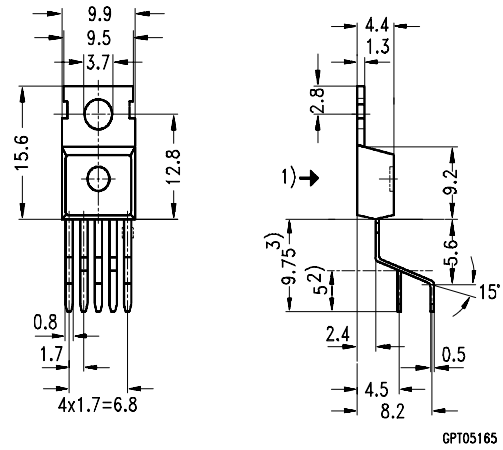

GPT05165

- 1) shear and punch direction no burrs this surface
- 2) min. length by finning
- 3) max. 11 mm allowable by finning

Ordering Code: Q67060-S6700-A3

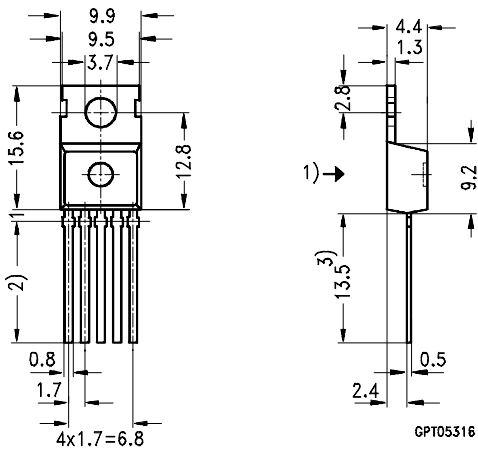

GPT05316

- 1) punch direction, burr max. 0.04
- 2) dip finning
- 3) max. 14.5 by dip finning press burr max. 0.05

**Edition 7.97**

**Published by Siemens AG,  
Bereich Halbleiter Vertrieb,  
Werbung, Balanstraße 73,  
81541 München**

© Siemens AG 1997

All Rights Reserved.

**Attention please!**

As far as patents or other rights of third parties are concerned, liability is only assumed for components, not for applications, processes and circuits implemented within components or assemblies.

The information describes a type of component and shall not be considered as warranted characteristics.

Terms of delivery and rights to change design reserved.

For questions on technology, delivery and prices please contact the Semiconductor Group Offices in Germany or the Siemens Companies and Representatives worldwide (see address list).

Due to technical requirements components may contain dangerous substances. For information on the types in question please contact your nearest Siemens Office, Semiconductor Group.

Siemens AG is an approved CECC manufacturer.

**Packing**

Please use the recycling operators known to you. We can also help you - get in touch with your nearest sales office. By agreement we will take packing material back, if it is sorted. You must bear the costs of transport.

For packing material that is returned to us unsorted or which we are not obliged to accept, we shall have to invoice you for any costs incurred.

**Components used in life-support devices or systems must be expressly authorized for such purpose!**

Critical components<sup>1</sup> of the Semiconductor Group of Siemens AG, may only be used in life-support devices or systems<sup>2</sup> with the express written approval of the Semiconductor Group of Siemens AG.

- 1) A critical component is a component used in a life-support device or system whose failure can reasonably be expected to cause the failure of that life-support device or system, or to affect its safety or effectiveness of that device or system.
- 2) Life support devices or systems are intended (a) to be implanted in the human body, or (b) to support and/or maintain and sustain and/or protect human life. If they fail, it is reasonable to assume that the health of the user or other persons may be endangered.