

Integrated Silicon Pressure Sensor On-Chip Signal Conditioned, Temperature Compensated and Calibrated

The MPX5100/MPXV5100 series piezoresistive transducer is a state-of-the-art monolithic silicon pressure sensor designed for a wide range of applications, but particularly those employing a microcontroller or microprocessor with A/D inputs. This patented, single element transducer combines advanced micromachining techniques, thin-film metallization, and bipolar processing to provide an accurate, high level analog output signal that is proportional to the applied pressure.

Features

- 2.5% Maximum Error over 0° to 85°C
- Ideally suited for Microprocessor or Microcontroller-Based Systems
- Patented Silicon Shear Stress Strain Gauge
- Available in Absolute, Differential and Gauge Configurations
- Ideal for Automotive and Non-Automotive Applications

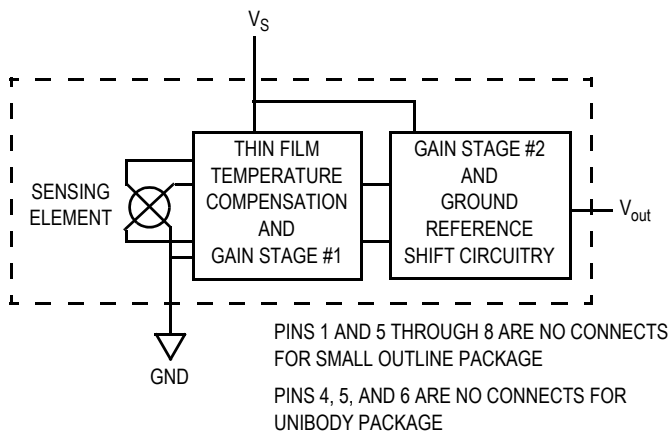

Figure 1. Fully Integrated Pressure Sensor Schematic

MPX5100/MPXV5100 SERIES

INTEGRATED PRESSURE SENSOR

Differential 0 to 100 kPa (0 to 14.5 psi)
Absolute 15 to 115 kPa (2.18 to 16.68 psi)
0.2 to 4.7 Volts Output

SMALL OUTLINE PACKAGE

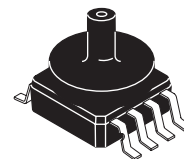

MPXV5100GC6U
CASE 482A

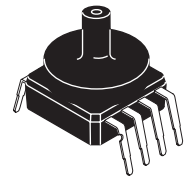

MPXV5100GC7U
CASE 482C

UNIBODY PACKAGE

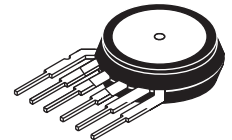

MPX5100D
CASE 867

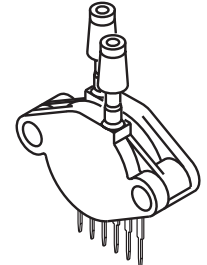

MPX5100DP
CASE 867C

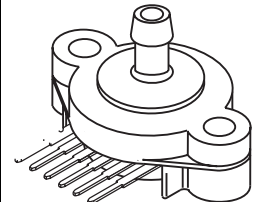

MPX5100GSX
CASE 867F

PIN NUMBER

1	N/C	5	N/C
2	V _s	6	N/C
3	GND	7	N/C
4	V _{out}	8	N/C

NOTE: Pins 1, 5, 6, 7, and 8 are internal device connections. Do not connect to external circuitry or ground. Pin1 is noted by the notch in the lead.

PIN NUMBER

1	V _{out}	4	N/C
2	GND	5	N/C
3	V _s	6	N/C

NOTE: Pins 4, 5, and 6 are internal device connections. Do not connect to external circuitry or ground. Pin1 is noted by the notch in the lead.

Freescale Semiconductor, Inc.

MPX5100/MPXV5100 SERIES

Table 1. MAXIMUM RATINGS^(NOTE)

Rating	Symbol	Value	Unit
Maximum Pressure (P1 > P2)	P_{max}	400	kPa
Storage Temperature	T_{stg}	-40° to +125°	°C
Operating Temperature	T_A	-40° to +125°	°C

NOTE: Exposure beyond the specified limits may cause permanent damage or degradation to the device.

Table 2. OPERATING CHARACTERISTICS ($V_S = 5.0$ Vdc, $T_A = 25^\circ\text{C}$ unless otherwise noted, P1 > P2. Decoupling circuit shown in Figure 4 required to meet electrical specifications.)

Characteristic	Symbol	Min	Typ	Max	Unit
Pressure Range ⁽¹⁾ Gauge, Differential: MPX5100D/MPX5100G/MPXV5100G Absolute: MPX5100A	P_{OP}	0 15	— —	100 115	kPa
Supply Voltage ⁽²⁾	V_S	4.75	5.0	5.25	Vdc
Supply Current	I_o	—	7.0	10	mAdc
Minimum Pressure Offset ⁽³⁾ @ $V_S = 5.0$ Volts (0 to 85°C)	V_{off}	0.088	0.20	0.313	Vdc
Full Scale Output ⁽⁴⁾ Differential and Absolute (0 to 85°C) @ $V_S = 5.0$ Volts	V_{FSO}	4.587	4.700	4.813	Vdc
Full Scale Span ⁽⁵⁾ Differential and Absolute (0 to 85°C) @ $V_S = 5.0$ Volts	V_{FSS}	—	4.500	—	Vdc
Accuracy ⁽⁶⁾	—	—	—	± 2.5	% V_{FSS}
Sensitivity	V/P	—	45	—	mV/kPa
Response Time ⁽⁷⁾	t_R	—	1.0	—	ms
Output Source Current at Full Scale Output	I_{O+}	—	0.1	—	mAdc
Warm-Up Time ⁽⁸⁾	—	—	20	—	ms
Offset Stability ⁽⁹⁾	—	—	± 0.5	—	% V_{FSS}

NOTES:

- 1.0kPa (kiloPascal) equals 0.145 psi.
- Device is ratiometric within this specified excitation range.
- Offset (V_{off}) is defined as the output voltage at the minimum rated pressure.
- Full Scale Output (V_{FSO}) is defined as the output voltage at the maximum or full rated pressure.
- Full Scale Span (V_{FSS}) is defined as the algebraic difference between the output voltage at full rated pressure and the output voltage at the minimum rated pressure.
- Accuracy (error budget) consists of the following:
 - Linearity: Output deviation from a straight line relationship with pressure over the specified pressure range.
 - Temperature Hysteresis: Output deviation at any temperature within the operating temperature range, after the temperature is cycled to and from the minimum or maximum operating temperature points, with zero differential pressure applied.
 - Pressure Hysteresis: Output deviation at any pressure within the specified range, when this pressure is cycled to and from minimum or maximum rated pressure at 25°C.
 - TcSpan: Output deviation over the temperature range of 0° to 85°C, relative to 25°C.
 - TcOffset: Output deviation with minimum pressure applied, over the temperature range of 0° to 85°C, relative to 25°C.
 - Variation from Nominal: The variation from nominal values, for Offset or Full Scale Span, as a percent of V_{FSS} at 25°C.
- Response Time is defined as the time for the incremental change in the output to go from 10% to 90% of its final value when subjected to a specified step change in pressure.
- Warm-up Time is defined as the time required for the product to meet the specified output voltage after the Pressure has been stabilized.
- Offset Stability is the product's output deviation when subjected to 1000 hours of Pulsed Pressure, Temperature Cycling with Bias Test.

Table 3. MECHANICAL CHARACTERISTICS

Characteristics	Typ	Unit
Weight, Basic Element (Case 867)	4.0	grams
Weight, Basic Element (Case 482)	1.5	grams

ON-CHIP TEMPERATURE COMPENSATION, CALIBRATION AND SIGNAL CONDITIONING

Figure 2 shows the sensor output signal relative to pressure input. Typical, minimum, and maximum output curves are shown for operation over a temperature range of 0° to 85°C using the decoupling circuit shown in Figure 4. The output will saturate outside of the specified pressure range.

Figure 3 illustrates both the Differential/Gauge and the Absolute Sensing Chip in the basic chip carrier (Case 867). A fluoro-silicone gel isolates the die surface and wire bonds from the environment, while allowing the pressure signal to be transmitted to the sensor diaphragm.

The MPX5100/MPXV5100 series pressure sensor operating characteristics, and internal reliability and qualification tests are based on use of dry air as the pressure media. Media, other than dry air, may have adverse effects on sensor performance and long-term reliability. Contact the factory for information regarding media compatibility in your application.

Figure 4 shows the recommended decoupling circuit for interfacing the output of the integrated sensor to the A/D input of a microprocessor or microcontroller. Proper decoupling of the power supply is recommended.

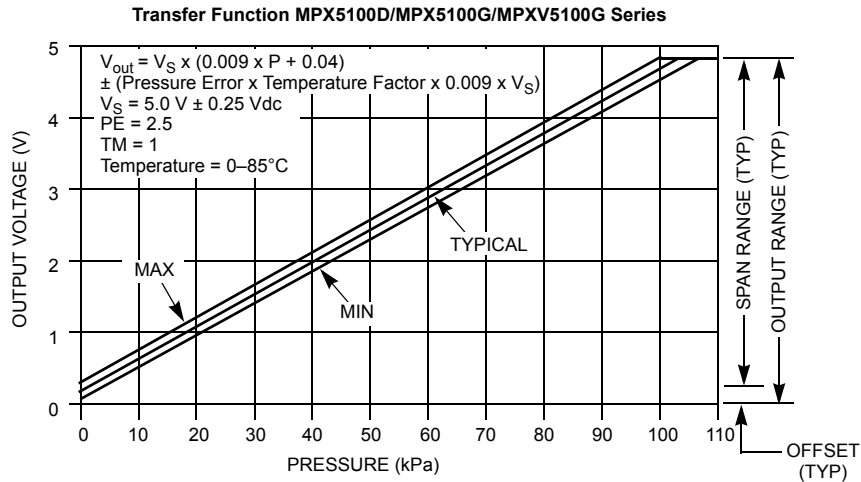

Figure 2. Output versus Pressure Differential

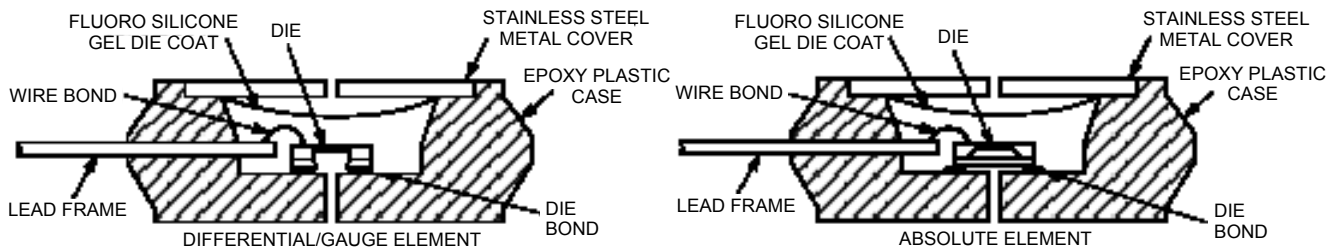

Figure 3. Cross-Sectional Diagrams (Not to Scale)

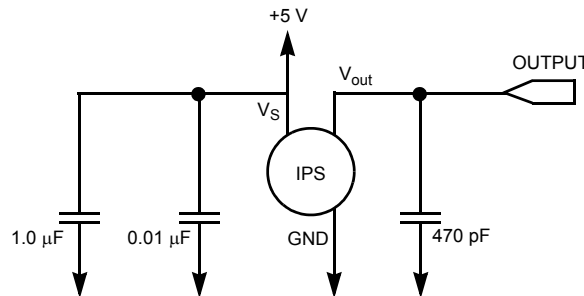

Figure 4. Recommended Power Supply Decoupling and Output Filtering (For additional output filtering, please refer to Application Note AN1646)

Transfer Function (MPX5100D, MPX5100G, MPXV5100G)

Nominal Transfer Value: $V_{out} = V_S (P \times 0.009 + 0.04)$
 $\pm (\text{Pressure Error} \times \text{Temp. Mult.} \times 0.009 \times V_S)$
 $V_S = 5.0 \text{ V} \pm 5\% \text{ P kPa}$

Temperature Error Multiplier

MPX5100D/MPX5100G/MPXV5100G Series

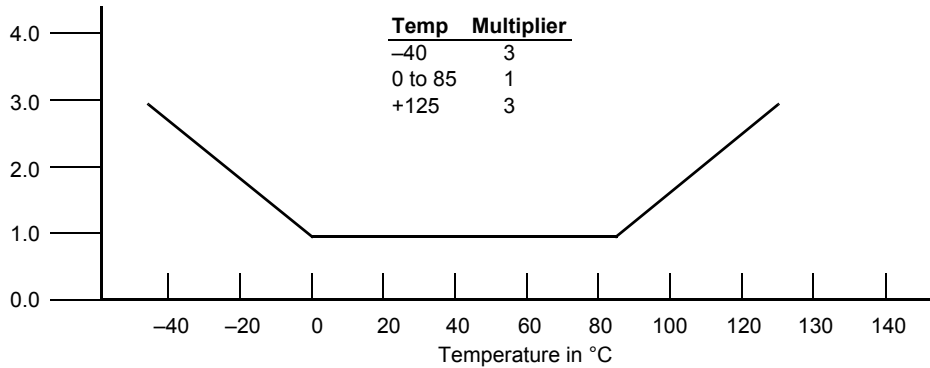

NOTE: The Temperature Multiplier is a linear response from 0° to -40°C and from 85° to 125°C.

Pressure Error Band

MPX5100D/MPX5100G/MPXV5100G Series

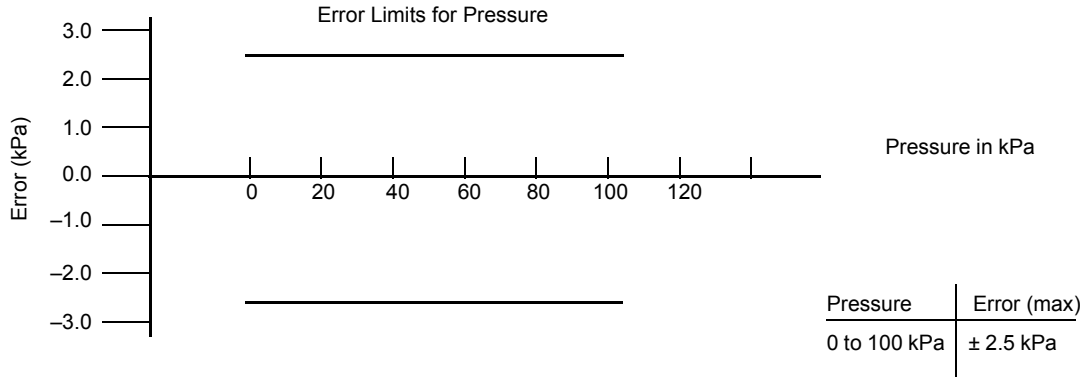

Transfer Function (MPX5100A)

Nominal Transfer Value: $V_{out} = V_S (P \times 0.009 - 0.095)$
 $\pm (\text{Pressure Error} \times \text{Temp. Mult.} \times 0.009 \times V_S)$
 $V_S = 5.0 \text{ V} \pm 5\% \text{ P kPa}$

Temperature Error Multiplier

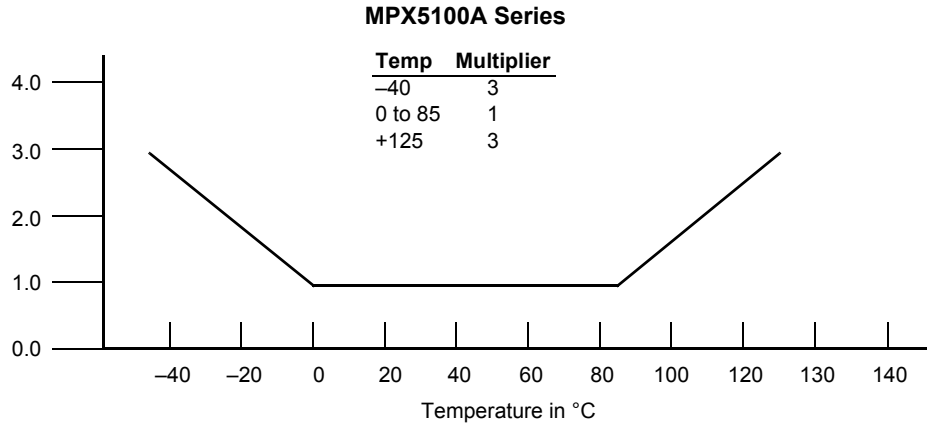

NOTE: The Temperature Multiplier is a linear response from 0° to -40°C and from 85° to 125°C.

Pressure Error Band

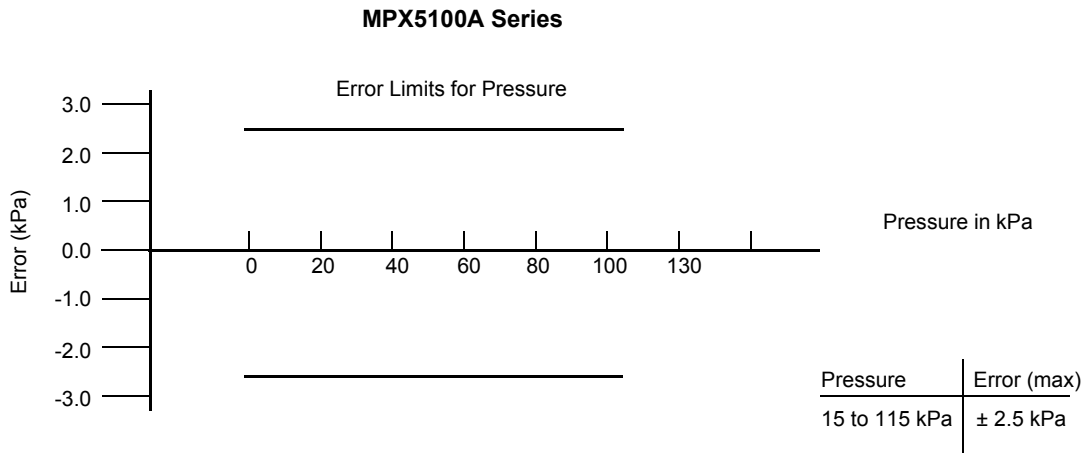

Freescale Semiconductor, Inc.

PRESSURE (P1)/VACUUM (P2) SIDE IDENTIFICATION TABLE

Motorola designates the two sides of the pressure sensor as the Pressure (P1) side and the Vacuum (P2) side. The Pressure (P1) side is the side containing fluoro silicone gel which protects the die from harsh media. The Motorola MPX pressure sensor

is designed to operate with positive differential pressure applied, $P1 > P2$.

The Pressure (P1) side may be identified by using the Table below:

Part Number	Case Type	Pressure (P1) Side Identifier
MPX5100A, MPX5100D	867	Stainless Steel Cap
MPX5100DP	867C	Side with Part Marking
MPX5100AP, MPX5100GP	867B	Side with Port Attached
MPX5100GSX	867F	Side with Port Attached
MPXV5100GC6U	482A	Side with Port Attached
MPXV5100GC7U	482C	Side with Port Attached

ORDERING INFORMATION

The MPX5100/MPXV5100 pressure sensor is available in absolute, differential, gauge, and vacuum configurations. Devices are available in the basic element package or with pressure port fittings that provide printed circuit board mounting ease and barbed hose pressure connections.

Device Name	Options	Case Type	MPX Series	
			Order Number	Device Marking
Basic Element	Absolute	867	MPX5100A	MPX5100A
	Differential	867	MPX5100D	MPX5100D
Ported Elements	Differential Dual Ports	867C	MPX5100DP	MPX5100DP
	Absolute, Single Port	867B	MPX5100AP	MPX5100AP
	Gauge, Single Port	867B	MPX5100GP	MPX5100GP
	Gauge, Axial PC Mount	867F	MPX5100GSX	MPX5100D
	Gauge, Axial Port, SMT	482A	MPXV5100GC6U	MPXV5100G
	Gauge, Axial Port, DIP	482C	MPXV5100GC7U	MPXV5100G

INFORMATION FOR USING THE SMALL OUTLINE PACKAGE (CASE 482)

MINIMUM RECOMMENDED FOOTPRINT FOR SURFACE MOUNTED APPLICATIONS

Surface mount board layout is a critical portion of the total design. The footprint for the surface mount packages must be the correct size to ensure proper solder connection interface between the board and the package. With the correct footprint,

the packages will self align when subjected to a solder reflow process. It is always recommended to design boards with a solder mask layer to avoid bridging and shorting between solder pads.

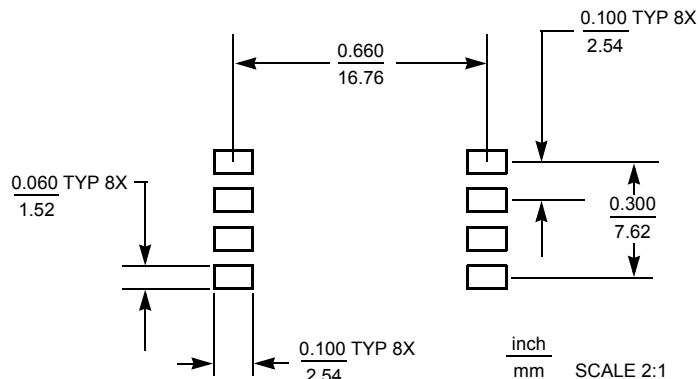
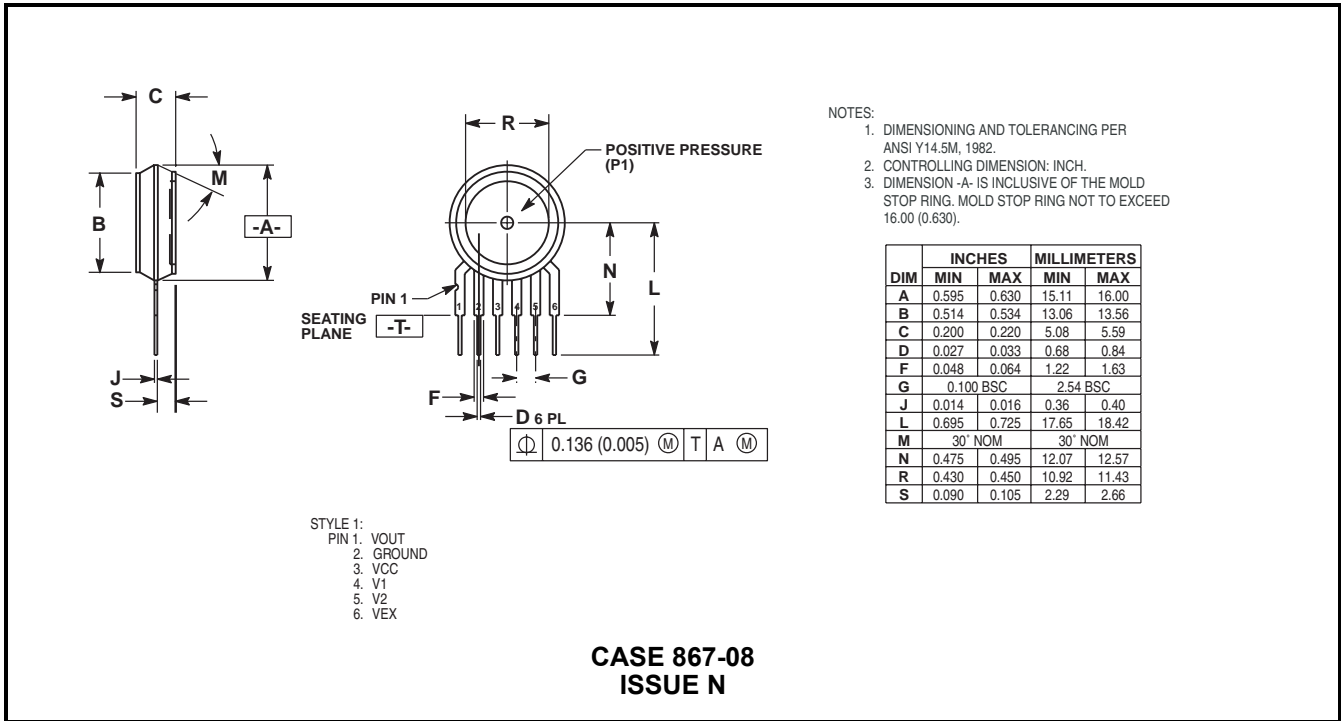
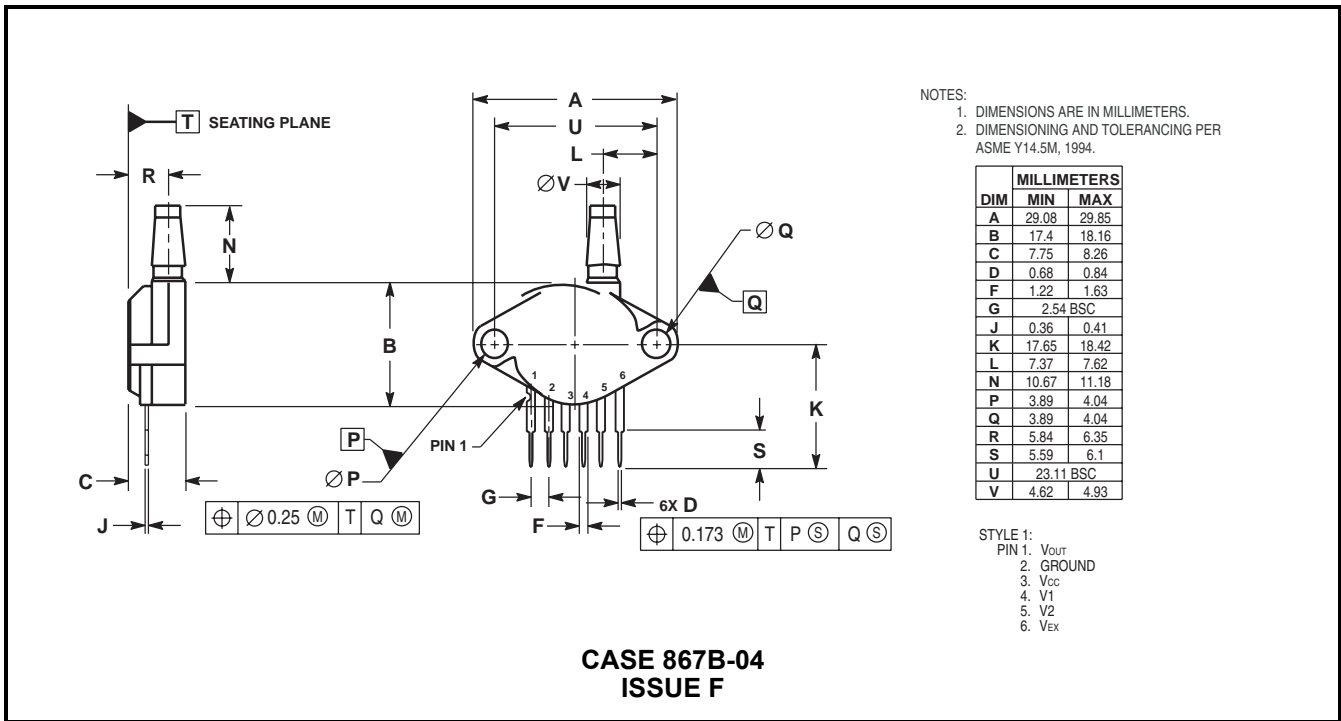

Figure 5. SOP Footprint (Case 482)

PACKAGE DIMENSIONS



BASIC ELEMENT



PRESSURE SIDE PORTED (AP, GP)

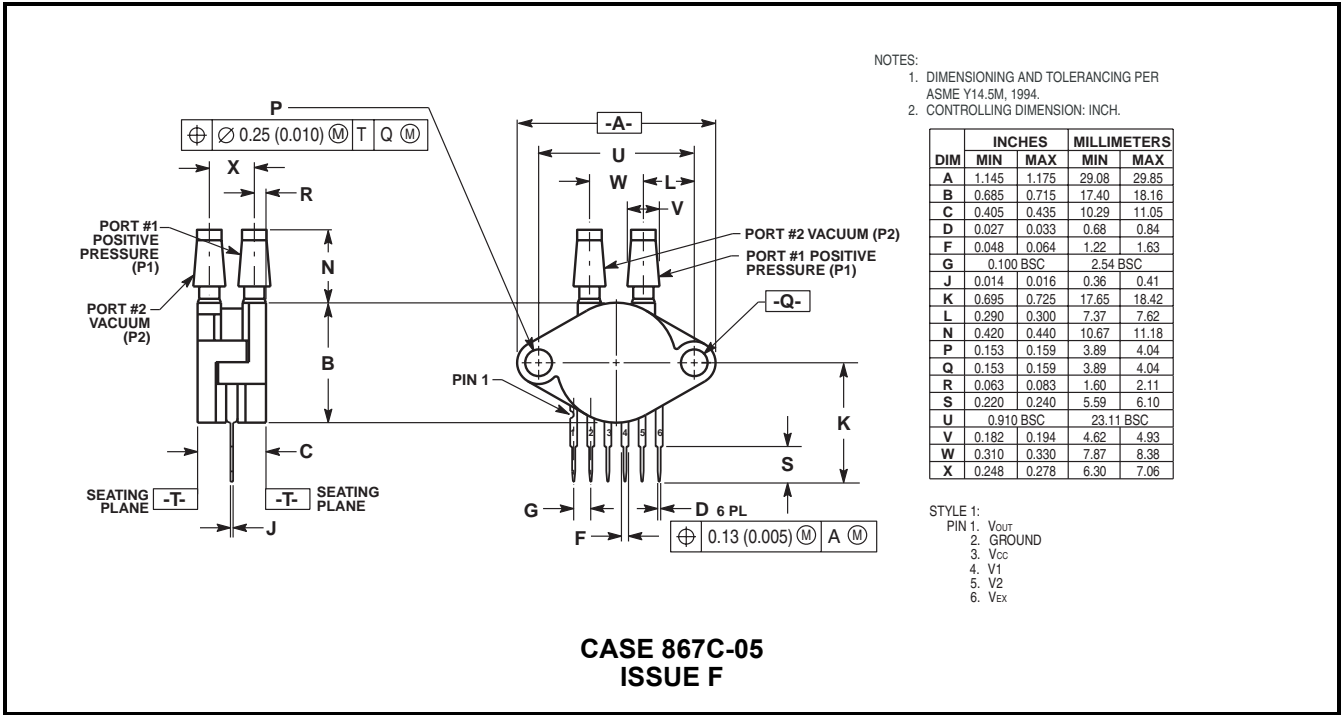

PRESSURE AND VACUUM SIDES PORTED (DP)

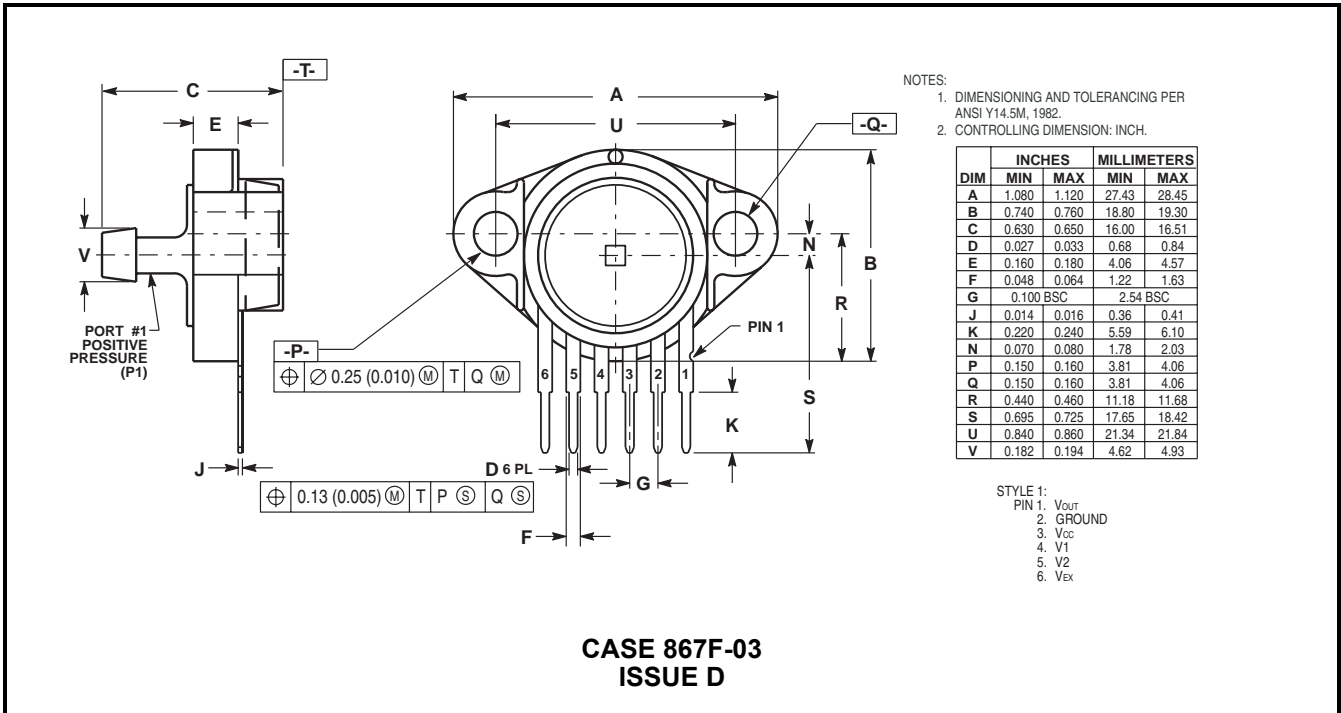

PRESSURE SIDE AXIAL PORT (GSX)

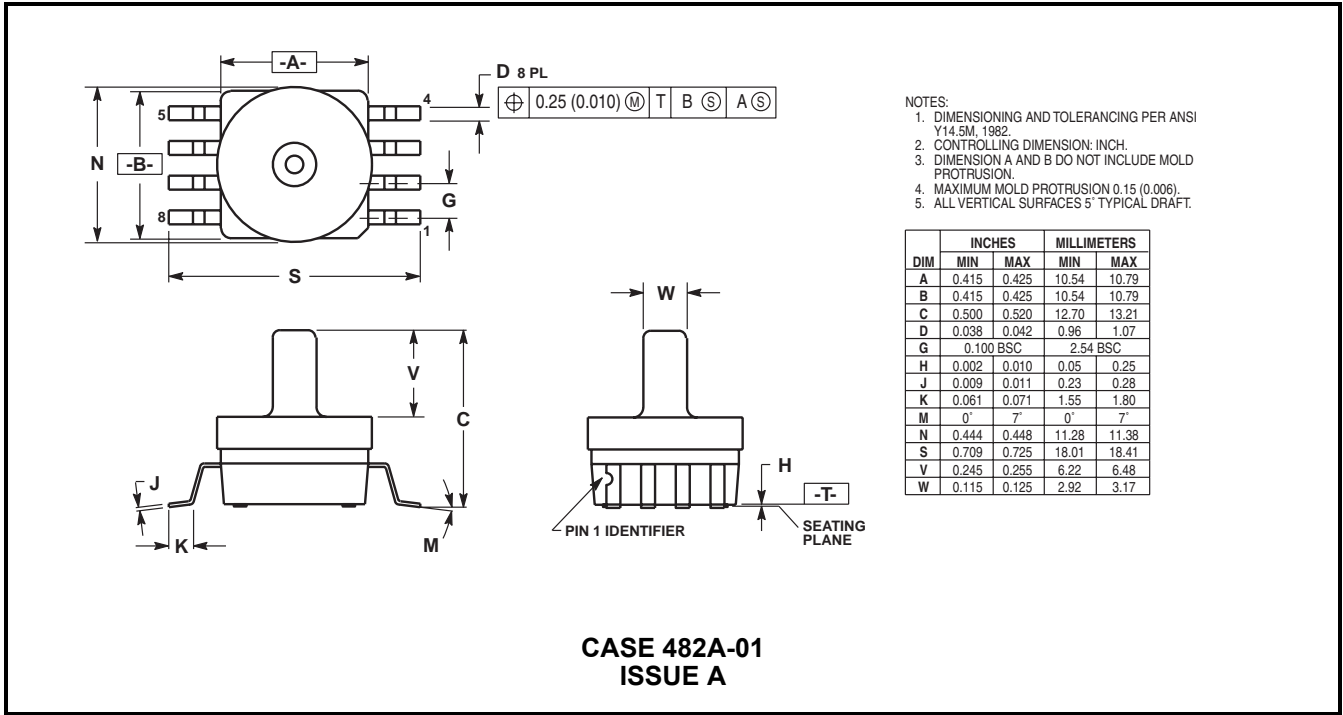

SMALL OUTLINE PACKAGE SURFACE MOUNT

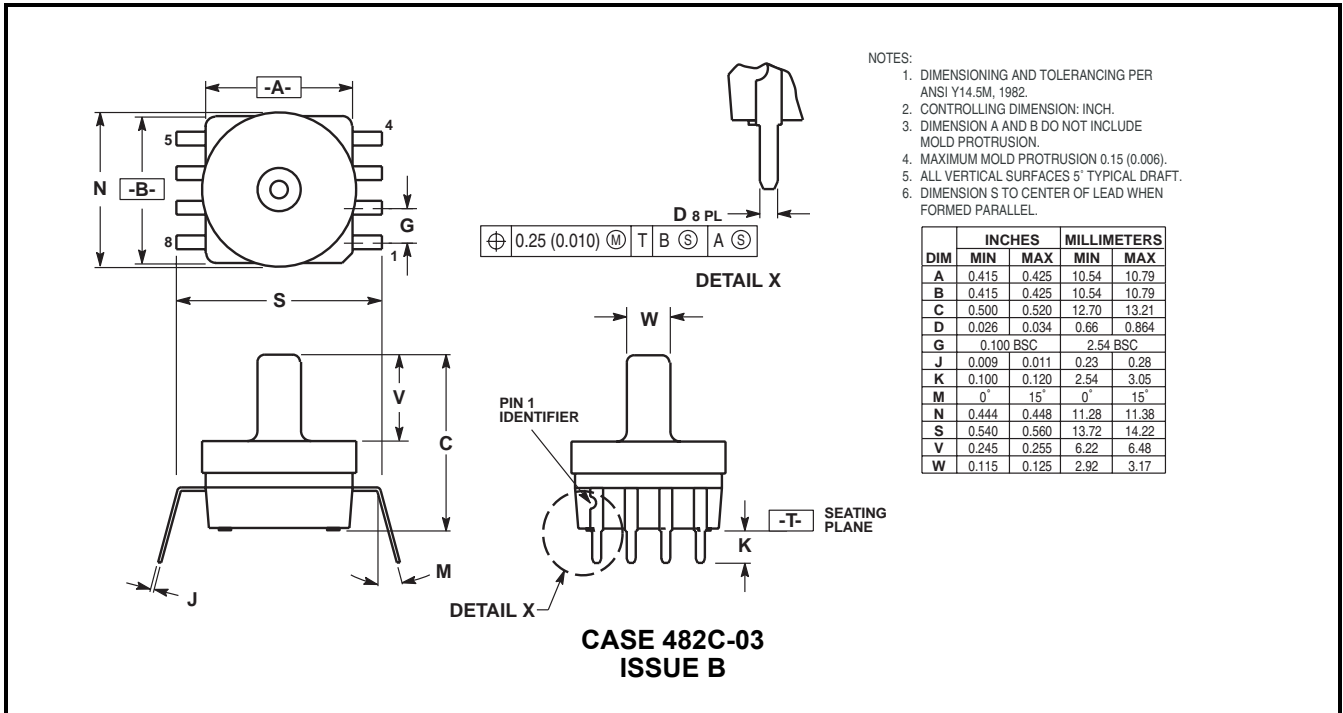

SMALL OUTLINE PACKAGE THROUGH-HOLE

NOTES

NOTES

Information in this document is provided solely to enable system and software implementers to use Motorola products. There are no express or implied copyright licenses granted hereunder to design or fabricate any integrated circuits or integrated circuits based on the information in this document.

Motorola reserves the right to make changes without further notice to any products herein. Motorola makes no warranty, representation or guarantee regarding the suitability of its products for any particular purpose, nor does Motorola assume any liability arising out of the application or use of any product or circuit, and specifically disclaims any and all liability, including without limitation consequential or incidental damages. "Typical" parameters which may be provided in Motorola data sheets and/or specifications can and do vary in different applications and actual performance may vary over time. All operating parameters, including "Typicals" must be validated for each customer application by customer's technical experts. Motorola does not convey any license under its patent rights nor the rights of others. Motorola products are not designed, intended, or authorized for use as components in systems intended for surgical implant into the body, or other applications intended to support or sustain life, or for any other application in which the failure of the Motorola product could create a situation where personal injury or death may occur. Should Buyer purchase or use Motorola products for any such unintended or unauthorized application, Buyer shall indemnify and hold Motorola and its officers, employees, subsidiaries, affiliates, and distributors harmless against all claims, costs, damages, and expenses, and reasonable attorney fees arising out of, directly or indirectly, any claim of personal injury or death associated with such unintended or unauthorized use, even if such claim alleges that Motorola was negligent regarding the design or manufacture of the part.

MOTOROLA and the Stylized M Logo are registered in the US Patent and Trademark Office. All other product or service names are the property of their respective owners.

© Motorola, Inc. 2004

HOW TO REACH US:

USA/EUROPE/LOCATIONS NOT LISTED:
Motorola Literature Distribution
P.O. Box 5405, Denver, Colorado 80217
1-800-521-6274 or 480-768-2130

JAPAN: Motorola Japan Ltd.; SPS, Technical Information Center
3-20-1 Minami-Azabu, Minato-ku, Tokyo 106-8573, Japan
81-3-3440-3569

ASIA/PACIFIC: Motorola Semiconductors H.K. Ltd.; Silicon Harbour Centre
2 Dai King Street, Tai Po Industrial Estate, Tai Po, N.T., Hong Kong
852-26668334

HOME PAGE: <http://motorola.com/semiconductors>



MOTOROLA

MPX5100/D

**For More Information On This Product,
Go to: www.freescale.com**