

## Super Voltage Converter

The ICL7660S Super Voltage Converter is a monolithic CMOS voltage conversion IC that guarantees significant performance advantages over other similar devices. It is a direct replacement for the industry standard ICL7660 offering an **extended** operating supply voltage range up to 12V, with **lower** supply current. **No external diode** is needed for the ICL7660S. In addition, a **Frequency Boost pin** has been incorporated to enable the user to achieve lower output impedance despite using smaller capacitors. All improvements are highlighted in the Electrical Specifications section. **Critical parameters are guaranteed over the entire commercial, industrial and military temperature ranges.**

The ICL7660S performs supply voltage conversion from positive to negative for an input range of 1.5V to 12V, resulting in complementary output voltages of -1.5V to -12V. Only 2 non-critical external capacitors are needed for the charge pump and charge reservoir functions. The ICL7660S can be connected to function as a voltage doubler and will generate up to 22.8V with a 12V input. It can also be used as a voltage multiplier or voltage divider.

The chip contains a series DC power supply regulator, RC oscillator, voltage level translator, and four output power MOS switches. The oscillator, when unloaded, oscillates at a nominal frequency of 10kHz for an input supply voltage of 5.0V. This frequency can be lowered by the addition of an external capacitor to the "OSC" terminal, or the oscillator may be over-driven by an external clock.

The "LV" terminal may be tied to GND to bypass the internal series regulator and improve low voltage (LV) operation. At medium to high voltages (3.5V to 12V), the LV pin is left floating to prevent device latchup.

## Ordering Information

PART NUMBER	TEMP. RANGE (°C)	PACKAGE	PKG. NO.
ICL7660SCBA	0 to 70	8 Ld P SOIC (N)	M8.15
ICL7660SCPA	0 to 70	8 Ld PDIP	E8.3
ICL7660SIBA	-40 to 85	8 Ld P SOIC (N)	M8.15
ICL7660SIPA	-40 to 85	8 Ld PDIP	E8.3
ICL7660SMTV (Note)	-55 to 125	8 Pin Metal Can	T8.C

NOTE: Add /883B to part number if 883B processing is required.

## Features

- Guaranteed Lower Max Supply Current for All Temperature Ranges
- Wide Operating Voltage Range 1.5V to 12V
- 100% Tested at 3V
- No External Diode Over Full Temperature and Voltage Range
- Boost Pin (Pin 1) for Higher Switching Frequency
- Guaranteed Minimum Power Efficiency of 96%
- Improved Minimum Open Circuit Voltage Conversion Efficiency of 99%
- Improved SCR Latchup Protection
- Simple Conversion of +5V Logic Supply to ±5V Supplies
- Simple Voltage Multiplication  $V_{OUT} = (-)nV_{IN}$
- Easy to Use - Requires Only 2 External Non-Critical Passive Components
- Improved Direct Replacement for Industry Standard ICL7660 and Other Second Source Devices

## Applications

- Simple Conversion of +5V to ±5V Supplies
- Voltage Multiplication  $V_{OUT} = \pm nV_{IN}$
- Negative Supplies for Data Acquisition Systems and Instrumentation
- RS232 Power Supplies
- Supply Splitter,  $V_{OUT} = \pm V_S/2$

## Pinouts

ICL7660S (PDIP, SOIC)  
TOP VIEW

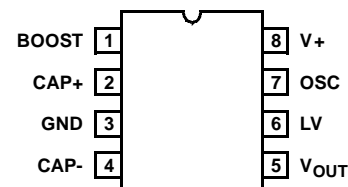

ICL7660S (CAN)  
TOP VIEW

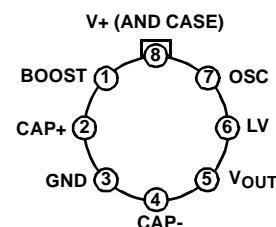

**Absolute Maximum Ratings**

Supply Voltage	+13.0V
LV and OSC Input Voltage (Note 1)	
V+ < 5.5V	-0.3V to V+ + 0.3V
V+ > 5.5V	V+ -5.5V to V+ +0.3V
Current into LV (Note 1)	
V+ > 3.5V	20μA
Output Short Duration	
V <sub>SUPPLY</sub> ≤ 5.5V	Continuous
Storage Temperature Range	-65°C to 150°C

**Thermal Information**

Thermal Resistance (Typical, Note 2)	$\theta_{JA}$ (°C/W)	$\theta_{JC}$ (°C/W)
PDIP	150	N/A
Plastic SOIC	170	N/A
Metal Can	155	70
Maximum Lead Temperature (Soldering 10s)	300°C (SOIC - Lead Tips Only)	

**Operating Conditions**

Temperature Range	
ICL7660SM	-55°C to 125°C
ICL7660SI	-40°C to 85°C
ICL7660SC	0°C to 70°C

CAUTION: Stresses above those listed in "Absolute Maximum Ratings" may cause permanent damage to the device. This is a stress only rating and operation of the device at these or any other conditions above those indicated in the operational sections of this specification is not implied.

NOTES:

1. Connecting any terminal to voltages greater than V+ or less than GND may cause destructive latchup. It is recommended that no inputs from sources operating from external supplies be applied prior to "power up" of ICL7660S.
2.  $\theta_{JA}$  is measured with the component mounted on an evaluation PC board in free air.

**Electrical Specifications** V+ = 5V, T<sub>A</sub> = 25°C, OSC = Free running, Test Circuit Figure 12, Unless Otherwise Specified

PARAMETER	SYMBOL	TEST CONDITIONS	MIN	TYP	MAX	UNITS
Supply Current (Note 5)	I+	R <sub>L</sub> = ∞, 25°C	-	80	160	μA
		0°C < T <sub>A</sub> < +70°C	-	-	180	μA
		-40°C < T <sub>A</sub> < 85°C	-	-	180	μA
		-55°C < T <sub>A</sub> < 125°C	-	-	200	μA
Supply Voltage Range - High (Note 6)	V <sub>+H</sub>	R <sub>L</sub> = 10K, LV Open, T <sub>MIN</sub> < T <sub>A</sub> < T <sub>MAX</sub>	3.0	-	12	V
Supply Voltage Range - Low	V <sub>+L</sub>	R <sub>L</sub> = 10K, LV to GND, T <sub>MIN</sub> < T <sub>A</sub> < T <sub>MAX</sub>	1.5	-	3.5	V
Output Source Resistance	R <sub>OUT</sub>	I <sub>OUT</sub> = 20mA	-	60	100	Ω
		I <sub>OUT</sub> = 20mA, 0°C < T <sub>A</sub> < 70°C	-	-	120	Ω
		I <sub>OUT</sub> = 20mA, -25°C < T <sub>A</sub> < 85°C	-	-	120	Ω
		I <sub>OUT</sub> = 20mA, -55°C < T <sub>A</sub> < 125°C	-	-	150	Ω
		I <sub>OUT</sub> = 3mA, V+ = 2V, LV = GND, 0°C < T <sub>A</sub> < 70°C	-	-	250	Ω
		I <sub>OUT</sub> = 3mA, V+ = 2V, LV = GND, -40°C < T <sub>A</sub> < 85°C	-	-	300	Ω
		I <sub>OUT</sub> = 3mA, V+ = 2V, LV = GND, -55°C < T <sub>A</sub> < 125°C	-	-	400	Ω
Oscillator Frequency (Note 5)	f <sub>OSC</sub>	C <sub>OSC</sub> = 0, Pin 1 Open or GND	5	10	-	kHz
		C <sub>OSC</sub> = 0, Pin 1 = V+	-	35	-	kHz
Power Efficiency	P <sub>EFF</sub>	R <sub>L</sub> = 5kΩ	96	98	-	%
		T <sub>MIN</sub> < T <sub>A</sub> < T <sub>MAX</sub> R <sub>L</sub> = 5kΩ	95	97	-	-
Voltage Conversion Efficiency	V <sub>OUTEFF</sub>	R <sub>L</sub> = ∞	99	99.9	-	%

**Electrical Specifications**  $V_+ = 5V$ ,  $T_A = 25^\circ C$ , OSC = Free running, Test Circuit Figure 12, Unless Otherwise Specified (Continued)

PARAMETER	SYMBOL	TEST CONDITIONS	MIN	TYP	MAX	UNITS
Oscillator Impedance	$Z_{OSC}$	$V_+ = 2V$	-	1	-	$M\Omega$
		$V_+ = 5V$	-	100	-	$k\Omega$

NOTES:

- Derate linearly above  $50^\circ C$  by  $5.5mW/^\circ C$
- In the test circuit, there is no external capacitor applied to pin 7. However, when the device is plugged into a test socket, there is usually a very small but finite stray capacitance present, of the order of  $5pF$ .
- The Intersil ICL7660S can operate without an external diode over the full temperature and voltage range. This device will function in existing designs which incorporate an external diode with no degradation in overall circuit performance.
- All significant improvements over the industry standard ICL7660 are highlighted.

**Typical Performance Curves** (Test Circuit Figure 12)

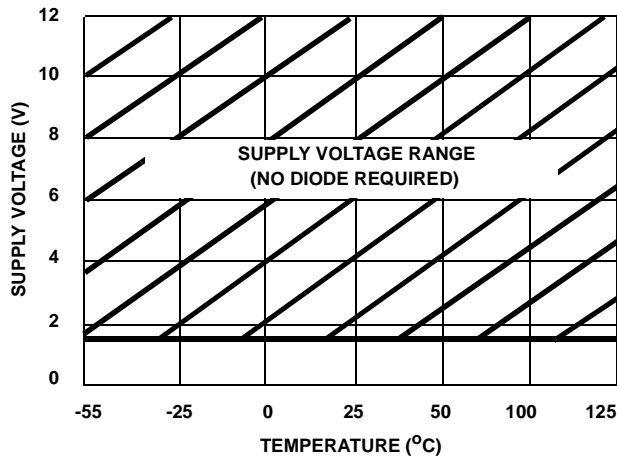

FIGURE 1. OPERATING VOLTAGE AS A FUNCTION OF TEMPERATURE

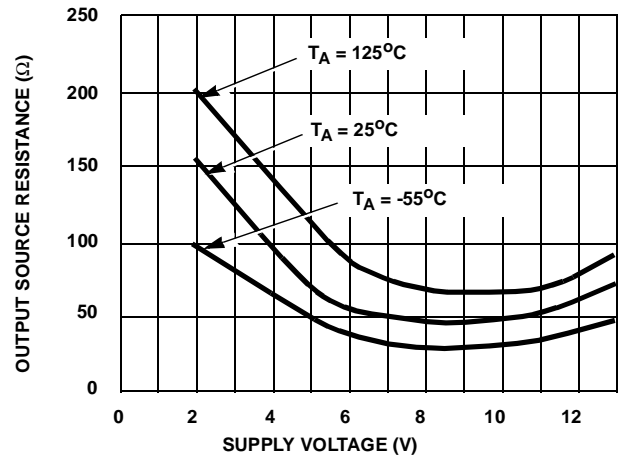

FIGURE 2. OUTPUT SOURCE RESISTANCE AS A FUNCTION OF SUPPLY VOLTAGE

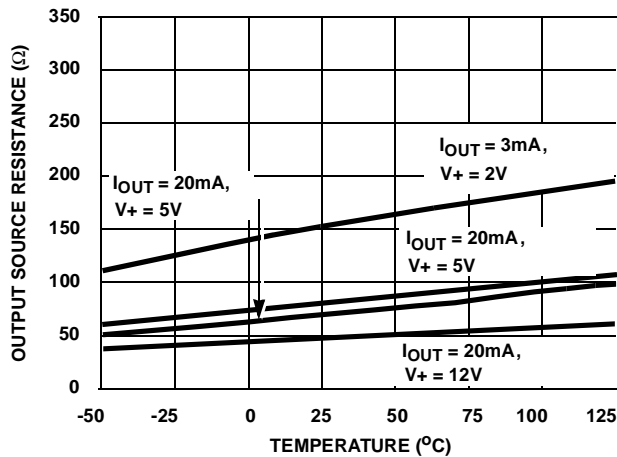

FIGURE 3. OUTPUT SOURCE RESISTANCE AS A FUNCTION OF TEMPERATURE

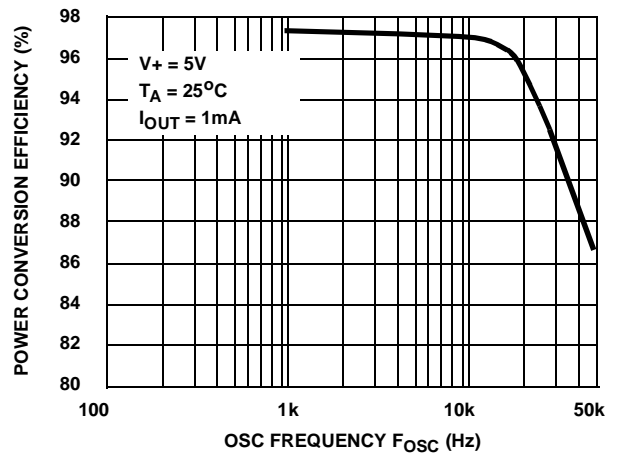

FIGURE 4. POWER CONVERSION EFFICIENCY AS A FUNCTION OF OSCILLATOR FREQUENCY

Typical Performance Curves (Test Circuit Figure 12) (Continued)

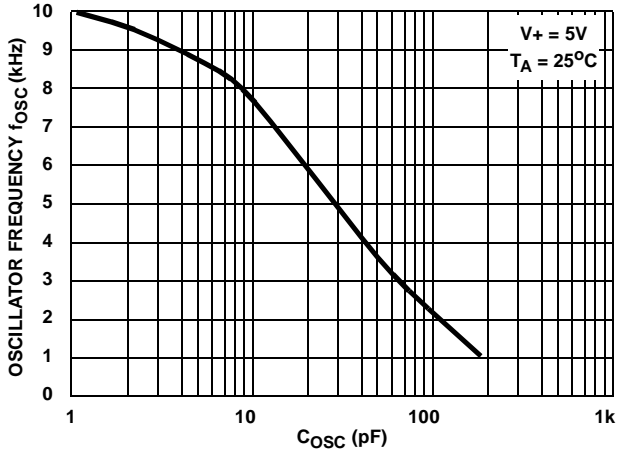

FIGURE 5. FREQUENCY OF OSCILLATION AS A FUNCTION OF EXTERNAL OSCILLATOR CAPACITANCE

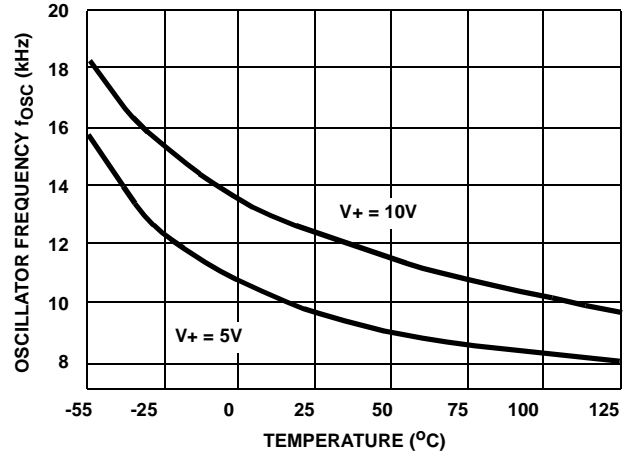

FIGURE 6. UNLOADED OSCILLATOR FREQUENCY AS A FUNCTION OF TEMPERATURE

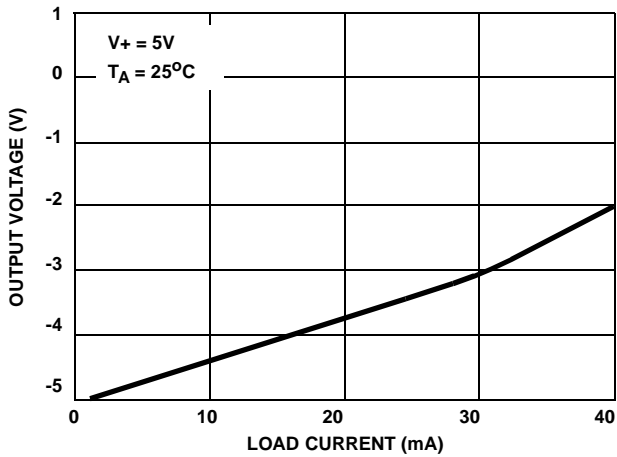

FIGURE 7. OUTPUT VOLTAGE AS A FUNCTION OF OUTPUT CURRENT

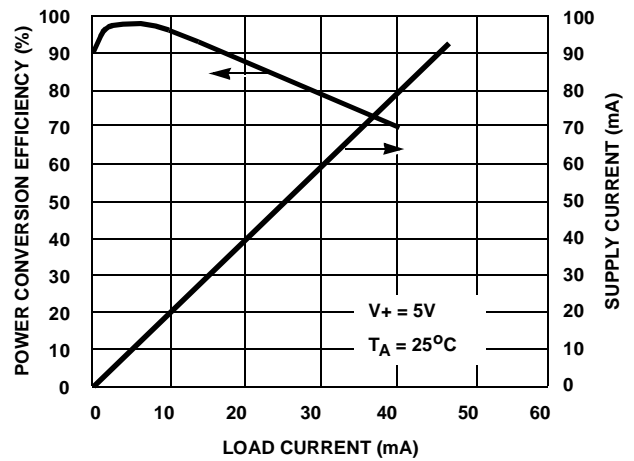

FIGURE 8. SUPPLY CURRENT AND POWER CONVERSION EFFICIENCY AS A FUNCTION OF LOAD CURRENT

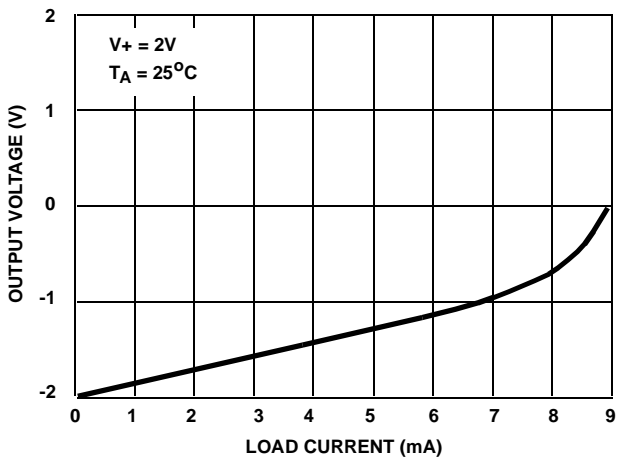

FIGURE 9. OUTPUT VOLTAGE AS A FUNCTION OF OUTPUT CURRENT

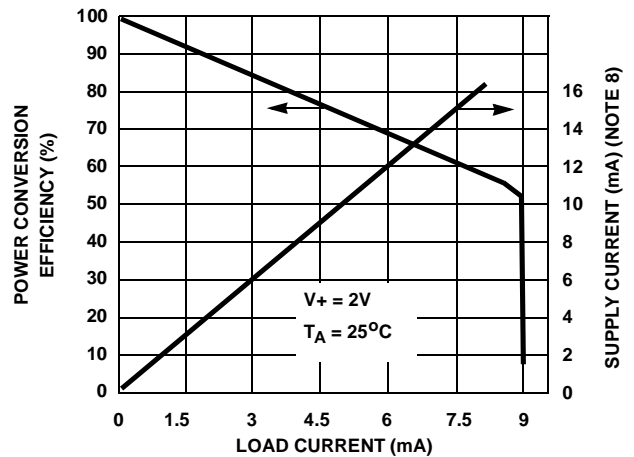
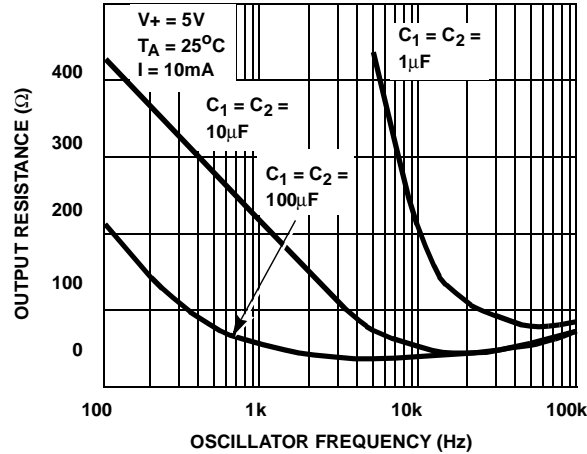

FIGURE 10. SUPPLY CURRENT AND POWER CONVERSION EFFICIENCY AS A FUNCTION OF LOAD CURRENT

**Typical Performance Curves** (Test Circuit Figure 12) (Continued)



**FIGURE 11. OUTPUT SOURCE RESISTANCE AS A FUNCTION OF OSCILLATOR FREQUENCY**

NOTE:

- These curves include in the supply current that current fed directly into the load  $R_L$  from the  $V_+$  (See Figure 12). Thus, approximately half the supply current goes directly to the positive side of the load, and the other half, through the ICL7660S, to the negative side of the load. Ideally,  $V_{OUT} \approx 2V_{IN}$ ,  $I_S \approx 2I_L$ , so  $V_{IN} \times I_S \approx V_{OUT} \times I_L$ .

**Detailed Description**

The ICL7660S contains all the necessary circuitry to complete a negative voltage converter, with the exception of 2 external capacitors which may be inexpensive 10 $\mu$ F polarized electrolytic types. The mode of operation of the device may be best understood by considering Figure 13, which shows an idealized negative voltage converter.

Capacitor  $C_1$  is charged to a voltage,  $V_+$ , for the half cycle when switches  $S_1$  and  $S_3$  are closed. (Note: Switches  $S_2$  and  $S_4$  are open during this half cycle.) During the second half cycle of operation, switches  $S_2$  and  $S_4$  are closed, with  $S_1$  and  $S_3$  open, thereby shifting capacitor  $C_1$  to  $C_2$  such that the voltage on  $C_2$  is exactly  $V_+$ , assuming ideal switches and no load on  $C_2$ . The ICL7660S approaches this ideal situation more closely than existing non-mechanical circuits.

$S_3$  and  $S_4$  must always remain reverse biased with respect to their sources, but not so much as to degrade their "ON" resistances. In addition, at circuit start up, and under output short circuit conditions ( $V_{OUT} = V_+$ ), the output voltage must be sensed and the substrate bias adjusted accordingly. Failure to accomplish this would result in high power losses and probable device latchup.

This problem is eliminated in the ICL7660S by a logic network which senses the output voltage ( $V_{OUT}$ ) together with the level translators, and switches the substrates of  $S_3$  and  $S_4$  to the correct level to maintain necessary reverse bias.

The voltage regulator portion of the ICL7660S is an integral part of the anti-latchup circuitry, however its inherent voltage drop can degrade operation at low voltages. Therefore, to improve low voltage operation "LV" pin should be connected to GND, disabling the regulator. For supply voltages greater than 3.5V the LV terminal must be left open to insure latchup proof operation, and prevent device damage.

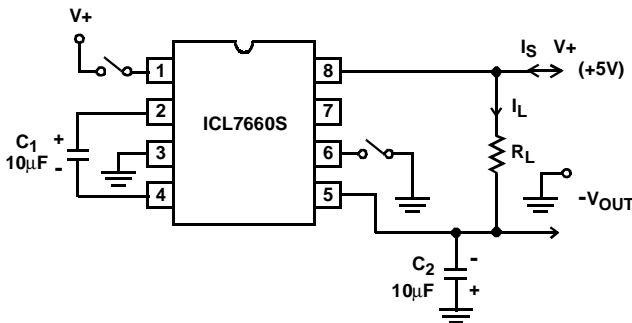

NOTE: For large values of  $C_{OSC}$  (>1000pF) the values of  $C_1$  and  $C_2$  should be increased to 100 $\mu$ F.

**FIGURE 12. ICL7660S TEST CIRCUIT**

In the ICL7660S, the 4 switches of Figure 13 are MOS power switches;  $S_1$  is a P-Channel devices and  $S_2$ ,  $S_3$  and  $S_4$  are N-Channel devices. The main difficulty with this approach is that in integrating the switches, the substrates of

**Theoretical Power Efficiency Considerations**

In theory a voltage converter can approach 100% efficiency if certain conditions are met:

- The drive circuitry consumes minimal power.
- The output switches have extremely low ON resistance and virtually no offset.
- The impedance of the pump and reservoir capacitors are negligible at the pump frequency.

The ICL7660S approaches these conditions for negative voltage conversion if large values of  $C_1$  and  $C_2$  are used. **ENERGY IS LOST ONLY IN THE TRANSFER OF CHARGE BETWEEN CAPACITORS IF A CHANGE IN VOLTAGE OCCURS.** The energy lost is defined by:

$$E = \frac{1}{2}C_1 (V_1^2 - V_2^2)$$

where  $V_1$  and  $V_2$  are the voltages on  $C_1$  during the pump and transfer cycles. If the impedances of  $C_1$  and  $C_2$  are relatively high at the pump frequency (refer to Figure 13) compared to the value of  $R_L$ , there will be substantial difference in the voltages  $V_1$  and  $V_2$ . Therefore it is not only desirable to make  $C_2$  as large as possible to eliminate output voltage ripple, but also to employ a correspondingly large value for  $C_1$  in order to achieve maximum efficiency of operation.

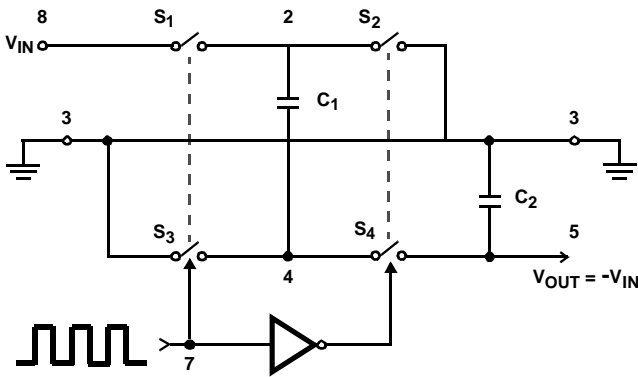

FIGURE 13. IDEALIZED NEGATIVE VOLTAGE CONVERTER

**Do's and Don'ts**

1. Do not exceed maximum supply voltages.
2. Do not connect LV terminal to GND for supply voltage greater than 3.5V.
3. Do not short circuit the output to  $V^+$  supply for supply voltages above 5.5V for extended periods, however, transient conditions including start-up are okay.
4. When using polarized capacitors, the + terminal of  $C_1$  must be connected to pin 2 of the ICL7660S and the + terminal of  $C_2$  must be connected to GND.
5. If the voltage supply driving the ICL7660S has a large source impedance ( $25\Omega - 30\Omega$ ), then a  $2.2\mu F$  capacitor from pin 8 to ground may be required to limit rate of rise of input voltage to less than  $2V/\mu s$ .
6. User should insure that the output (pin 5) does not go more positive than GND (pin 3). Device latch up will occur under these conditions.  
A 1N914 or similar diode placed in parallel with  $C_2$  will prevent the device from latching up under these conditions. (Anode pin 5, Cathode pin 3).

**Typical Applications**

**Simple Negative Voltage Converter**

The majority of applications will undoubtedly utilize the ICL7660S for generation of negative supply voltages. Figure 14 shows typical connections to provide a negative supply where a positive supply of +1.5V to +12V is available. Keep in mind that pin 6 (LV) is tied to the supply negative (GND) for supply voltage below 3.5V.

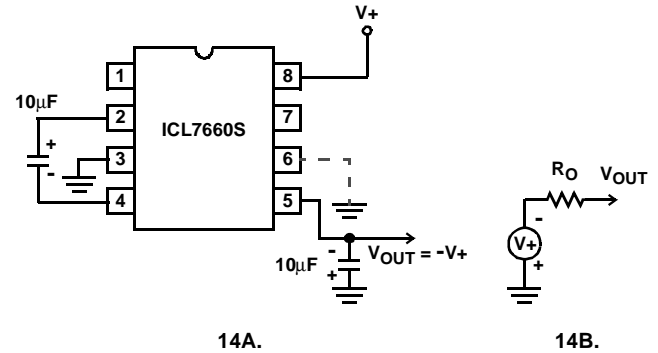

FIGURE 14. SIMPLE NEGATIVE CONVERTER AND ITS OUTPUT EQUIVALENT

The output characteristics of the circuit in Figure 14 can be approximated by an ideal voltage source in series with a resistance as shown in Figure 14B. The voltage source has a value of  $-(V^+)$ . The output impedance ( $R_O$ ) is a function of the ON resistance of the internal MOS switches (shown in Figure 13), the switching frequency, the value of  $C_1$  and  $C_2$ , and the ESR (equivalent series resistance) of  $C_1$  and  $C_2$ . A good first order approximation for  $R_O$  is:

$$R_O \cong 2(R_{SW1} + R_{SW3} + ESR_{C1}) + 2(R_{SW2} + R_{SW4} + ESR_{C1}) + \frac{1}{f_{PUMP} \times C_1} + ESR_{C2}$$

( $f_{PUMP} = \frac{f_{OSC}}{2}$ ,  $R_{SWX} =$  MOSFET switch resistance)

Combining the four  $R_{SWX}$  terms as  $R_{SW}$ , we see that:

$$R_O \cong 2 \times R_{SW} + \frac{1}{f_{PUMP} \times C_1} + 4 \times ESR_{C1} + ESR_{C2}$$

$R_{SW}$ , the total switch resistance, is a function of supply voltage and temperature (See the Output Source Resistance graphs), typically  $23\Omega$  at  $25^\circ C$  and 5V. Careful selection of  $C_1$  and  $C_2$  will reduce the remaining terms, minimizing the output impedance. High value capacitors will reduce the  $1/(f_{PUMP} \times C_1)$  component, and low ESR capacitors will lower the ESR term. Increasing the oscillator frequency will reduce the  $1/(f_{PUMP} \times C_1)$  term, but may have the side effect of a net increase in output impedance when  $C_1 > 10\mu F$  and is not long

enough to fully charge the capacitors every cycle. In a typical application where  $f_{OSC} = 10\text{kHz}$  and  $C = C_1 = C_2 = 10\mu\text{F}$ :

$$R_O \cong 2 \times 23 + \frac{1}{(5 \times 10^3 \times 10 \times 10^{-6})} + 4 \times \frac{ESR_{C_1}}{ESR_{C_2}}$$

$$R_O \cong 46 + 20 + 5 \times ESR_{C_2}$$

Since the ESRs of the capacitors are reflected in the output impedance multiplied by a factor of 5, a high value could potentially swamp out a low  $1/f_{PUMP} \times C_1$  term, rendering an increase in switching frequency or filter capacitance ineffective. Typical electrolytic capacitors may have ESRs as high as  $10\Omega$ .

**Output Ripple**

ESR also affects the ripple voltage seen at the output. The total ripple is determined by 2 voltages, A and B, as shown in Figure 15. Segment A is the voltage drop across the ESR of  $C_2$  at the instant it goes from being charged by  $C_1$  (current flowing into  $C_2$ ) to being discharged through the load (current flowing out of  $C_2$ ). The magnitude of this current change is  $2 \times I_{OUT}$ , hence the total drop is  $2 \times I_{OUT} \times ESR_{C_2}V$ . Segment B is the voltage change across  $C_2$  during time  $t_2$ , the half of the cycle when  $C_2$  supplies current the load. The drop at B is  $I_{OUT} \times t_2/C_2V$ . The peak-to-peak ripple voltage is the sum of these voltage drops:

$$V_{RIPPLE} \cong \left( \frac{1}{2 \times f_{PUMP} \times C_2} + 2 \times ESR_{C_2} \times I_{OUT} \right)$$

Again, a low ESR capacitor will result in a higher performance output.

**Paralleling Devices**

Any number of ICL7660S voltage converters may be paralleled to reduce output resistance. The reservoir capacitor,  $C_2$ , serves all devices while each device requires its own pump capacitor,  $C_1$ . The resultant output resistance would be approximately:

$$R_{OUT} = \frac{R_{OUT} \text{ (of ICL7660S)}}{n \text{ (number of devices)}}$$

**Cascading Devices**

The ICL7660S may be cascaded as shown to produce larger negative multiplication of the initial supply voltage. However, due to the finite efficiency of each device, the practical limit is 10 devices for light loads. The output voltage is defined by:

$$V_{OUT} = -n(V_{IN}),$$

where  $n$  is an integer representing the number of devices cascaded. The resulting output resistance would be approximately the weighted sum of the individual ICL7660S  $R_{OUT}$  values.

**Changing the ICL7660S Oscillator Frequency**

It may be desirable in some applications, due to noise or other considerations, to alter the oscillator frequency. This can be achieved simply by one of several methods described below.

By connecting the Boost Pin (Pin 1) to  $V+$ , the oscillator charge and discharge current is increased and, hence, the oscillator frequency is increased by approximately  $3^{1/2}$  times. The result is a decrease in the output impedance and ripple. This is of major importance for surface mount applications where capacitor size and cost are critical. Smaller capacitors, e.g.  $0.1\mu\text{F}$ , can be used in conjunction with the Boost Pin in order to achieve similar output currents compared to the device free running with  $C_1 = C_2 = 10\mu\text{F}$  or  $100\mu\text{F}$ . (Refer to graph of Output Source Resistance as a Function of Oscillator Frequency).

Increasing the oscillator frequency can also be achieved by overdriving the oscillator from an external clock, as shown in Figure 18. In order to prevent device latchup, a  $1\text{k}\Omega$  resistor must be used in series with the clock output. In a situation where the designer has generated the external clock frequency using TTL logic, the addition of a  $10\text{k}\Omega$  pullup resistor to  $V+$  supply is required. Note that the pump frequency with external clocking, as with internal clocking, will be  $1/2$  of the clock frequency. Output transitions occur on the positive going edge of the clock.

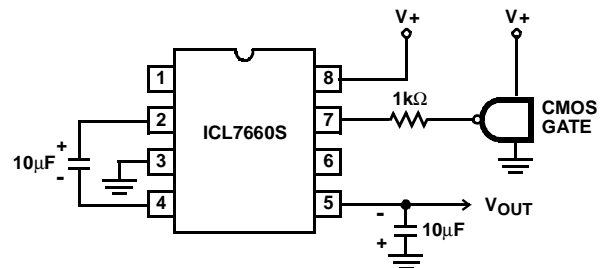

FIGURE 15. EXTERNAL CLOCKING

It is also possible to increase the conversion efficiency of the ICL7660S at low load levels by lowering the oscillator frequency. This reduces the switching losses, and is shown in Figure 19. However, lowering the oscillator frequency will cause an undesirable increase in the impedance of the pump ( $C_1$ ) and reservoir ( $C_2$ ) capacitors; this is overcome by increasing the values of  $C_1$  and  $C_2$  by the same factor that the frequency has been reduced. For example, the addition of a  $100\text{pF}$  capacitor between pin 7 (OSC and  $V+$ ) will lower the oscillator frequency to  $1\text{kHz}$  from its nominal frequency of  $10\text{kHz}$  (a multiple of 10), and thereby necessitate corresponding increase in the value of  $C_1$  and  $C_2$  (from  $10\mu\text{F}$  to  $100\mu\text{F}$ ).

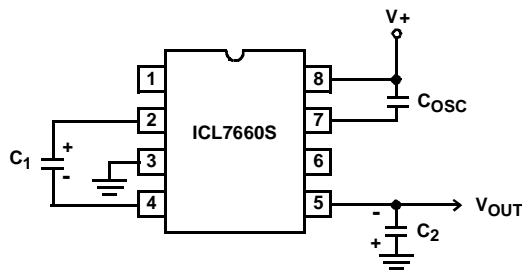
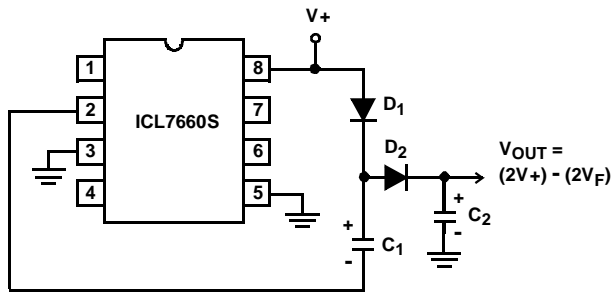

FIGURE 16. LOWERING OSCILLATOR FREQUENCY

**Positive Voltage Doubling**

The ICL7660S may be employed to achieve positive voltage doubling using the circuit shown in Figure 20. In this application, the pump inverter switches of the ICL7660S are used to charge  $C_1$  to a voltage level of  $V+ - V_F$  (where  $V+$  is the supply voltage and  $V_F$  is the forward voltage on  $C_1$  plus the supply voltage ( $V+$ ) is applied through diode  $D_2$  to capacitor  $C_2$ . The voltage thus created on  $C_2$  becomes  $(2V+) - (2V_F)$  or twice the supply voltage minus the combined forward voltage drops of diodes  $D_1$  and  $D_2$ .

The source impedance of the output ( $V_{OUT}$ ) will depend on the output current, but for  $V+ = 5V$  and an output current of 10mA it will be approximately 60Ω.



NOTE:  $D_1$  and  $D_2$  can be any suitable diode.

FIGURE 17. POSITIVE VOLTAGE DOUBLER

**Combined Negative Voltage Conversion and Positive Supply Doubling**

Figure 21 combines the functions shown in Figure 14 and Figure 20 to provide negative voltage conversion and positive voltage doubling simultaneously. This approach would be, for example, suitable for generating +9V and -5V from an existing +5V supply. In this instance capacitors  $C_1$  and  $C_3$  perform the pump and reservoir functions respectively for the generation of the negative voltage, while capacitors  $C_2$  and  $C_4$  are pump and reservoir respectively for the doubled positive voltage. There is a penalty in this configuration which combines both functions, however, in that the source impedances of the generated supplies will be somewhat higher due to the finite impedance of the common charge pump driver at pin 2 of the device.

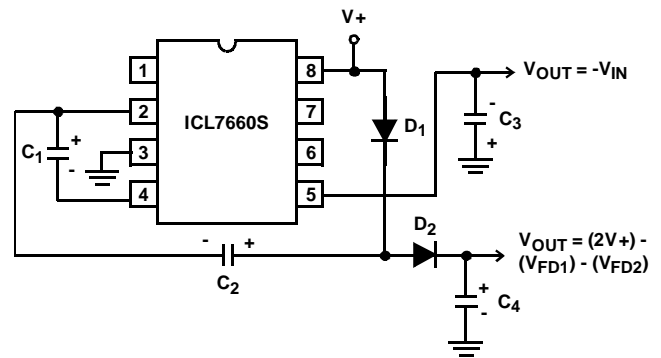

FIGURE 18. COMBINED NEGATIVE VOLTAGE CONVERTER AND POSITIVE DOUBLER

**Voltage Splitting**

The bidirectional characteristics can also be used to split a high supply in half, as shown in Figure 22. The combined load will be evenly shared between the two sides, and a high value resistor to the LV pin ensures start-up. Because the switches share the load in parallel, the output impedance is much lower than in the standard circuits, and higher currents can be drawn from the device. By using this circuit, and then the circuit of Figure 17, +15V can be converted (via +7.5, and -7.5 to a nominal -15V, although with rather high series output resistance (~250Ω).

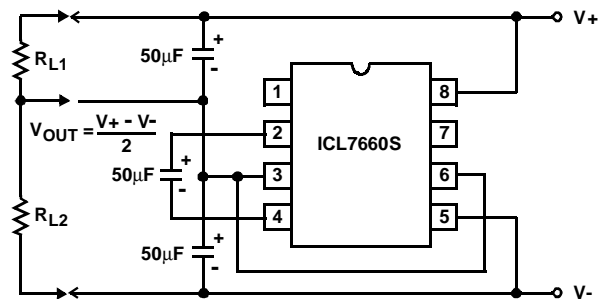

FIGURE 19. SPLITTING A SUPPLY IN HALF

**Regulated Negative Voltage Supply**

In Some cases, the output impedance of the ICL7660S can be a problem, particularly if the load current varies substantially. The circuit of Figure 23 can be used to overcome this by controlling the input voltage, via an ICL7611 low-power CMOS op amp, in such a way as to maintain a nearly constant output voltage. Direct feedback is inadvisable, since the ICL7660S's output does not respond instantaneously to change in input, but only after the switching delay. The circuit shown supplies enough delay to accommodate the ICL7660S, while maintaining adequate feedback. An increase in pump and storage capacitors is desirable, and the values shown provides an output impedance of less than 5Ω to a load of 10mA.



## ICL7660S

Further information on the operation and use of the ICL7660S may be found in AN051 "Principles and Applications of the ICL7660 CMOS Voltage Converter".

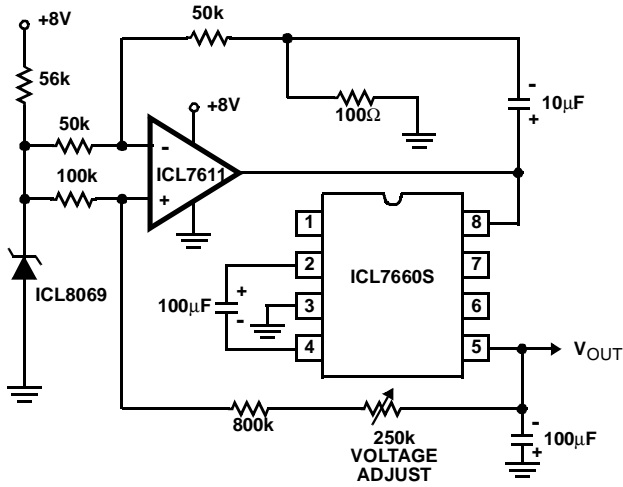

FIGURE 20. REGULATING THE OUTPUT VOLTAGE

### Other Applications

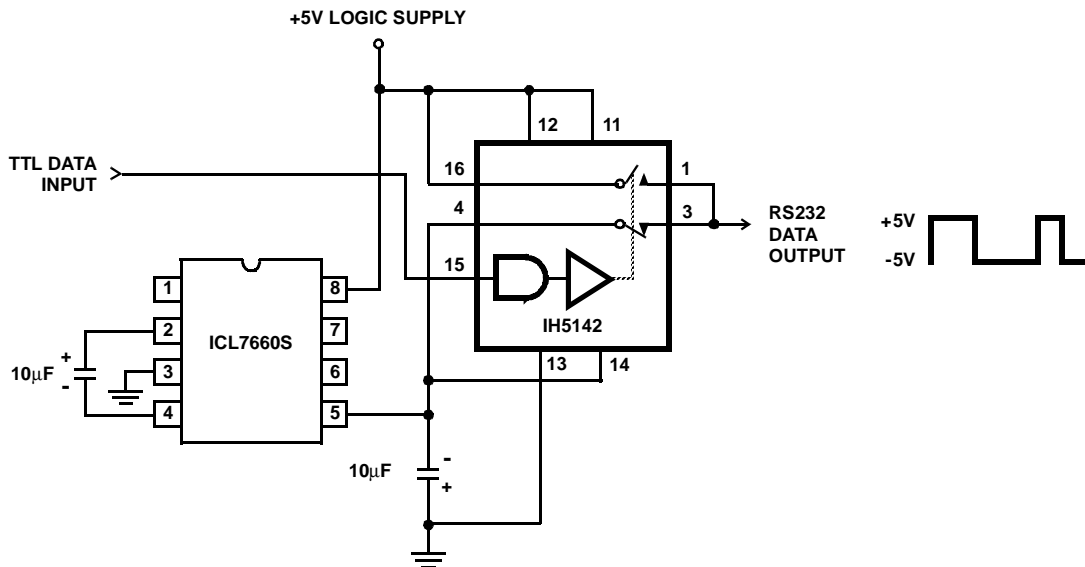

FIGURE 21. RS232 LEVELS FROM A SINGLE 5V SUPPLY