



MicroConverter™, Multichannel 12-Bit ADC with Embedded FLASH MCU

ADuC812

FEATURES

ANALOG I/O

- 8-Channel, High Accuracy 12-Bit ADC
- On-Chip, 40 ppm/°C Voltage Reference
- High Speed 200 kSPS
- DMA Controller for High Speed ADC-to-RAM Capture
- Two 12-Bit Voltage Output DACs
- On-Chip Temperature Sensor Function

MEMORY

- 8K Bytes On-Chip Flash/EE Program Memory
- 640 Bytes On-Chip Flash/EE Data Memory
- On-Chip Charge Pump (No Ext. V_{PP} Requirements)
- 256 Bytes On-Chip Data RAM
- 16M Bytes External Data Address Space
- 64K Bytes External Program Address Space

8051-COMPATIBLE CORE

- 12 MHz Nominal Operation (16 MHz Max)
- Three 16-Bit Timer/Counters
- 32 Programmable I/O lines
- High Current Drive Capability—Port 3
- Nine Interrupt Sources, Two Priority Levels

POWER

- Specified for 3 V and 5 V Operation
- Normal, Idle and Power-Down Modes

ON-CHIP PERIPHERALS

- UART Serial I/O
- 2-Wire (I²C®-Compatible) and SPI® Serial I/O
- Watchdog Timer
- Power Supply Monitor

APPLICATIONS

- Intelligent Sensors (IEEE 1451.2-Compatible)
- Battery Powered Systems (Portable PCs, Instruments, Monitors)
- Transient Capture Systems
- DAS and Communications Systems

GENERAL DESCRIPTION

The ADuC812 is a fully integrated 12-bit data acquisition system incorporating a high performance self-calibrating multichannel ADC, two 12-bit DACs and programmable 8-bit (8051-compatible) MCU on a single chip.

The programmable 8051-compatible core is supported by 8K bytes Flash/EE program memory, 640 bytes Flash/EE data memory and 256 bytes data SRAM on-chip.

Additional MCU support functions include Watchdog Timer, Power Supply Monitor and ADC DMA functions. 32 Programmable I/O lines, I²C-compatible, SPI and Standard UART Serial Port I/O are provided for multiprocessor interfaces and I/O expansion.

Normal, idle and power-down operating modes for both the MCU core and analog converters allow for flexible power management schemes suited to low power applications. The part is specified for 3 V and 5 V operation over the industrial temperature range and is available in a 52-lead, plastic quad flatpack package.

FUNCTIONAL BLOCK DIAGRAM

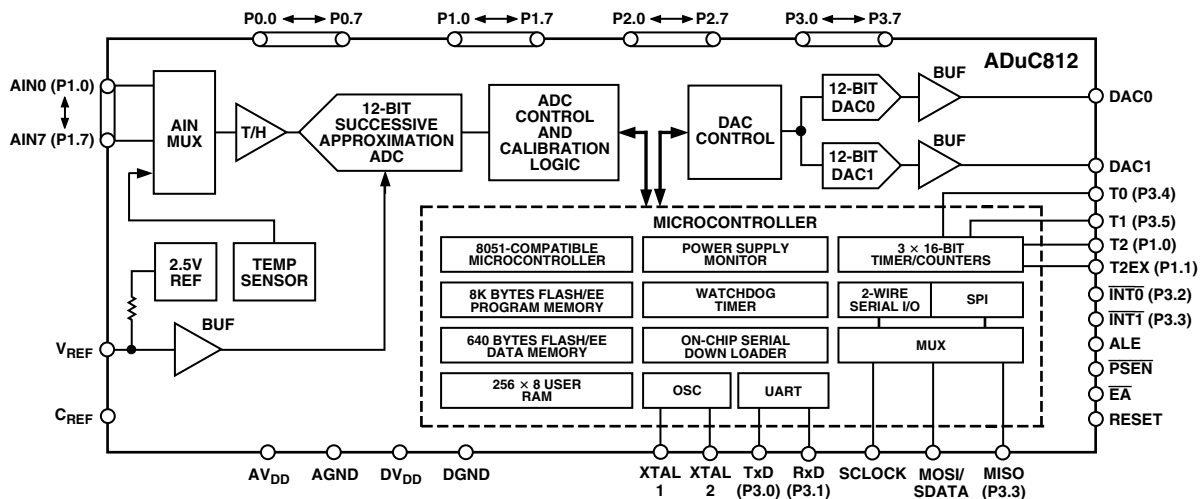

I²C is a registered trademark of Philips Corporation.
MicroConverter is a trademark of Analog Devices, Inc.
SPI is a registered trademark of Motorola Inc.

REV. 0

Information furnished by Analog Devices is believed to be accurate and reliable. However, no responsibility is assumed by Analog Devices for its use, nor for any infringements of patents or other rights of third parties which may result from its use. No license is granted by implication or otherwise under any patent or patent rights of Analog Devices.

One Technology Way, P.O. Box 9106, Norwood, MA 02062-9106, U.S.A.
Tel: 781/329-4700 World Wide Web Site: <http://www.analog.com>
Fax: 781/326-8703 © Analog Devices, Inc., 1999

ADuC812—SPECIFICATIONS^{1, 2}

($A_{V_{DD}} = DV_{DD} = +3.0\text{ V}$ or $+5.0\text{ V} \pm 10\%$, $V_{REF} = 2.5\text{ V}$ Internal Reference, $MCLKIN = 16.0\text{ MHz}$, DAC V_{OUT} Load to AGND; $R_L = 10\text{ k}\Omega$, $C_L = 100\text{ pF}$. All specifications $T_A = T_{MIN}$ to T_{MAX} , unless otherwise noted.)

Parameter	ADuC812BS		Units	Test Conditions/Comments
	$V_{DD} = 5\text{ V}$	$V_{DD} = 3\text{ V}$		
ADC CHANNEL SPECIFICATIONS				
DC ACCURACY^{3, 4}				
Resolution	12	12	Bits	$f_{SAMPLE} = 100\text{ kHz}$ $f_{SAMPLE} = 100\text{ kHz}$ $f_{SAMPLE} = 200\text{ kHz}$ $f_{SAMPLE} = 100\text{ kHz}$. Guaranteed No Missing Codes at 5 V
Integral Nonlinearity	$\pm 1/2$	$\pm 1/2$	LSB typ	
	± 1.5		LSB max	
Differential Nonlinearity	± 1.5	± 1.5	LSB typ	
	± 1	± 1	LSB typ	
CALIBRATED ENDPOINT ERRORS^{5, 6}				
Offset Error	± 5		LSB max	
	± 1	± 2	LSB typ	
Offset Error Match	1	1	LSB typ	
Gain Error	± 6		LSB max	
	± 1	± 2	LSB typ	
Gain Error Match	1.5	1.5	LSB typ	
USER SYSTEM CALIBRATION⁷				
Offset Calibration Range	± 5	± 5	% of V_{REF} typ	
Gain Calibration Range	± 2.5	± 2.5	% of V_{REF} typ	
DYNAMIC PERFORMANCE				
Signal-to-Noise Ratio (SNR) ⁸	70	70	dB typ	$f_{IN} = 10\text{ kHz}$ Sine Wave $f_{SAMPLE} = 100\text{ kHz}$
Total Harmonic Distortion (THD)	-78	-78	dB typ	
Peak Harmonic or Spurious Noise	-78	-78	dB typ	
ANALOG INPUT				
Input Voltage Ranges	0 to V_{REF}	0 to V_{REF}	Volts	
Leakage Current	± 10		μA max	
	± 1	+1	μA typ	
Input Capacitance	20	20	pF max	
TEMPERATURE SENSOR⁹				
Voltage Output at +25°C	600	600	mV typ	Measured On-Chip via a Typical ± 0.5 LSB (610 μV) Accurate ADC
Voltage TC	-3.0	-3.0	mV/°C typ	
DAC CHANNEL SPECIFICATIONS				
DC ACCURACY¹⁰				
Resolution	12	12	Bits	Guaranteed 12-Bit Monotonic
Relative Accuracy	± 3	± 3	LSB typ	
Differential Nonlinearity	± 0.5	± 1	LSB typ	
Offset Error	± 50		mV max	
	± 25	± 25	mV typ	
Full-Scale Error	± 25		mV max	
	± 10	± 10	mV typ	
Full-Scale Mismatch	± 0.5	± 0.5	% typ	% of Full-Scale on DAC1
ANALOG OUTPUTS				
Voltage Range_0	0 to V_{REF}	0 to V_{REF}	V typ	
Voltage Range_1	0 to V_{DD}	0 to V_{DD}	V typ	
Resistive Load	10	10	k Ω typ	
Capacitive Load	100	100	pF typ	
Output Impedance	0.5	0.5	Ω typ	
I_{SINK}	50	50	μA typ	

Parameter	ADuC812BS		Units	Test Conditions/Comments
	V _{DD} = 5 V	V _{DD} = 3 V		
DAC AC CHARACTERISTICS				
Voltage Output Settling Time	15	15	μs typ	Full-Scale Settling Time to Within 1/2 LSB of Final Value 1 LSB Change at Major Carry
Digital-to-Analog Glitch Energy	10	10	nV sec typ	
REFERENCE INPUT/OUTPUT				
REF _{IN} Input Voltage Range	2.3/V _{DD}	2.3/V _{DD}	V min/max	
Input Impedance	150	150	kΩ typ	
REF _{OUT} Output Voltage	2.45/2.55		V min/max	
	2.5	2.5	V typ	
REF _{OUT} Tempco	40	40	ppm/°C typ	
FLASH/EE MEMORY PERFORMANCE CHARACTERISTICS^{11, 12}				
Endurance	10,000		Cycles min	
	50,000	50,000	Cycles typ	
Data Retention	10		Years min	
WATCHDOG TIMER CHARACTERISTICS				
Oscillator Frequency	64	64	kHz typ	
POWER SUPPLY MONITOR CHARACTERISTICS				
Power Supply Trip Point Accuracy	±2.5		% of Selected Nominal Trip Point Voltage max	
	±1.0	±1.0	% of Selected Nominal Trip Point Voltage typ	
DIGITAL INPUTS				
Input High Voltage (V _{INH})	2.4		V min	V _{IN} = 0 V or V _{DD} V _{IN} = 0 V or V _{DD}
Input Low Voltage (V _{INL})	0.8		V max	
Input Leakage Current (Port 0, \overline{EA})	±10		μA max	
	±1	±1	μA typ	
Logic 1 Input Current (All Digital Inputs)	±10		μA max	V _{IN} = V _{DD}
	±1	±1	μA typ	V _{IN} = V _{DD}
Logic 0 Input Current (Port 1, 2, 3)	-80		μA max	V _{IL} = 450 mV V _{IL} = 2 V V _{IL} = 2 V
	-40	-40	μA typ	
Logic 1-0 Transition Current (Port 1, 2, 3)	-700		μA max	
	-400	-400	μA typ	
Input Capacitance	10	10	pF typ	

ADuC812—SPECIFICATIONS^{1, 2}

Parameter	ADuC812BS		Units	Test Conditions/Comments
	V _{DD} = 5 V	V _{DD} = 3 V		
DIGITAL OUTPUTS				
Output High Voltage (V _{OH})	2.4		V min	V _{DD} = 4.5 V to 5.5 V I _{SOURCE} = 80 μA
	4.0	2.6	V typ	V _{DD} = 2.7 V to 3.3 V I _{SOURCE} = 20 μA
Output Low Voltage (V _{OL}) ALE, PSEN, Ports 0 and 2	0.4		V max	I _{SINK} = 1.6 mA
	0.2	0.2	V typ	I _{SINK} = 1.6 mA
Port 3	0.4		V max	I _{SINK} = 8 mA
	0.2	0.2	V typ	I _{SINK} = 8 mA
Floating State Leakage Current	±10		μA max	
	±5	±5	μA typ	
Floating State Output Capacitance	10	10	pF typ	
POWER REQUIREMENTS^{13, 14, 15}				
I _{DD} Normal Mode ¹⁶	42		mA max	MCLKIN = 16 MHz
	32	16	mA typ	MCLKIN = 16 MHz
	26	12	mA typ	MCLKIN = 12 MHz
	8	3	mA typ	MCLKIN = 1 MHz
I _{DD} Idle Mode	25		mA max	MCLKIN = 16 MHz
	18	17	mA typ	MCLKIN = 16 MHz
	15	6	mA typ	MCLKIN = 12 MHz
	7	2	mA typ	MCLKIN = 1 MHz
I _{DD} Power-Down Mode ¹⁷	50	50	μA max	
	5	5	μA typ	

NOTES

¹Specifications apply after calibration.

²Temperature range -40°C to +85°C.

³Linearity is guaranteed during normal MicroConverter Core operation.

⁴Linearity may degrade when programming or erasing the 640 Byte Flash/EE space during ADC conversion times due to on-chip charge pump activity.

⁵Measured in production at V_{DD} = 5 V after Software Calibration Routine at +25°C only.

⁶User may need to execute Software Calibration Routine to achieve these specifications, which are configuration dependent.

⁷The offset and gain calibration spans are defined as the voltage range of user system offset and gain errors that the ADuC812 can compensate.

⁸SNR calculation includes distortion and noise components.

⁹The temperature sensor will give a measure of the die temperature directly, air temperature can be inferred from this result.

¹⁰DAC linearity is calculated using:

reduced code range of 48 to 4095, 0 to V_{REF} range

reduced code range of 48 to 3995, 0 to V_{DD} range

DAC output load = 10 kΩ and 50 pF.

¹¹Flash/EE Memory Performance Specifications are qualified as per JEDEC Specification A103 (Data Retention) and JEDEC Draft Specification All7 (Endurance).

¹²Endurance Cycling is evaluated under the following conditions:

Mode = Byte Programming, Page Erase Cycling

Cycle Pattern = 00Hex to FFHex

Erase Time = 20 ms

Program Time = 100 μs

¹³I_{DD} at other MCLKIN frequencies is typically given by:

Normal Mode (V_{DD} = 5 V): I_{DD} = (1.6 × MCLKIN) + 6

Normal Mode (V_{DD} = 3 V): I_{DD} = (0.8 × MCLKIN) + 3

Idle Mode (V_{DD} = 5 V): I_{DD} = (0.75 × MCLKIN) + 6

Idle Mode (V_{DD} = 3 V): I_{DD} = (0.25 × MCLKIN) + 3

Where MCLKIN is the oscillator frequency in MHz and resultant I_{DD} values are in mA.

¹⁴I_{DD} Currents are expressed as a summation of analog and digital power supply currents during normal MicroConverter operation.

¹⁵I_{DD} is not measured during Flash/EE program or erase cycles; I_{DD} will typically increase by 10 mA during these cycles.

¹⁶Analog I_{DD} = 2 mA (typ) in normal operation (internal V_{REF}, ADC and DAC peripherals powered on).

¹⁷EA = Port0 = DV_{DD}, XTAL1 (Input) tied to DV_{DD}, during this measurement.

Typical specifications are not production tested, but are supported by characterization data at initial product release.

Specifications subject to change without notice.

Please refer to User Guide, Quick Reference Guide, Application Notes and Silicon Errata Sheet at www.analog.com/microconverter for additional information.

ABSOLUTE MAXIMUM RATINGS*

(T_A = +25°C unless otherwise noted)

AV _{DD} to DV _{DD}	-0.3 V to +0.3 V
AGND to DGND	-0.3 V to +0.3 V
DV _{DD} to DGND, AV _{DD} to AGND	-0.3 V to +7 V
Digital Input Voltage to DGND	-0.3 V, DV _{DD} + 0.3 V
Digital Output Voltage to DGND	-0.3 V, DV _{DD} + 0.3 V
V _{REF} to AGND	-0.3 V, AV _{DD} + 0.3 V
Analog Inputs to AGND	-0.3 V, AV _{DD} + 0.3 V
Operating Temperature Range	
Industrial (B Version)	-40°C to +85°C
Storage Temperature Range	-65°C to +150°C
Junction Temperature	+150°C
θ _{JA} Thermal Impedance	90°C/W
Lead Temperature, Soldering	
Vapor Phase (60 sec)	+215°C
Infrared (15 sec)	+220°C

*Stresses above those listed under Absolute Maximum Ratings may cause permanent damage to the device. This is a stress rating only; functional operation of the device at these or any other conditions above those listed in the operational sections of this specification is not implied. Exposure to absolute maximum rating conditions for extended periods may affect device reliability.

PIN CONFIGURATION

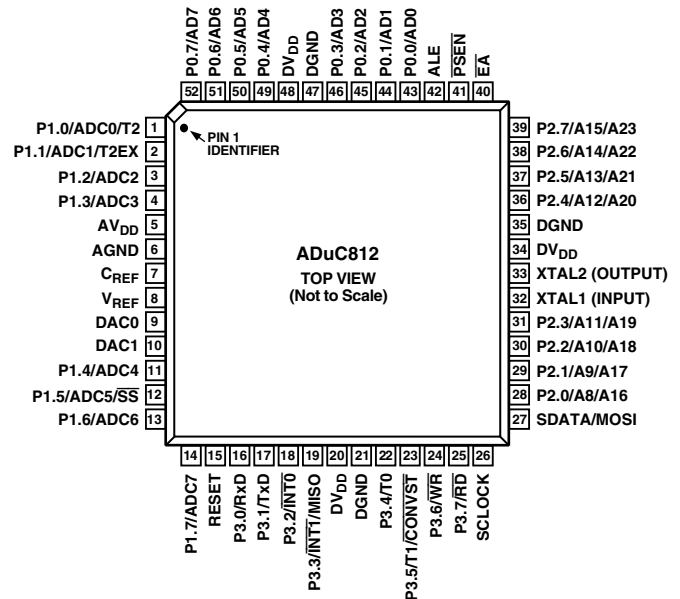

ORDERING GUIDE

Model	Temperature Range	Package Description	Package Option
ADuC812BS	-40°C to +85°C	52-Lead Plastic Quad Flatpack	S-52

QuickStart™ Development System
Eval-ADuC812QS

CAUTION

ESD (electrostatic discharge) sensitive device. Electrostatic charges as high as 4000 V readily accumulate on the human body and test equipment and can discharge without detection. Although the ADuC812 features proprietary ESD protection circuitry, permanent damage may occur on devices subjected to high energy electrostatic discharges. Therefore, proper ESD precautions are recommended to avoid performance degradation or loss of functionality.



PIN FUNCTION DESCRIPTIONS

Mnemonic	Type	Function
DV _{DD}	P	Digital Positive Supply Voltage, +3 V or +5 V nominal.
AV _{DD}	P	Analog Positive Supply Voltage, +3 V or +5 V nominal.
C _{REF}	I	Decoupling pin for on-chip reference. Connect 0.1 μF between this pin and AGND.
V _{REF}	I/O	Reference Input/Output. This pin is connected to the internal reference through a series resistor and is the reference source for the analog-to-digital converter. The nominal internal reference voltage is 2.5 V and this appears at the pin (once the ADC or DAC peripherals are enabled). This pin can be overdriven by an external reference.
AGND	G	Analog Ground. Ground Reference point for the analog circuitry.
P1.0–P1.7	I	Port 1 is an 8-bit Input Port only. Unlike other Ports, Port 1 defaults to Analog Input Mode, to configure any of these Port Pins as a digital input, write a “0” to the port bit. Port 1 pins are multifunction and share the following functionality.
ADC0–ADC7	I	Analog Inputs. Eight single-ended analog inputs. Channel selection is via ADCCON2 SFR.
T2	I	Timer 2 Digital Input. Input to Timer/Counter 2. When Enabled, Counter 2 is incremented in response to a 1 to 0 transition of the T2 input.
T2EX	I	Digital Input. Capture/Reload trigger for Counter 2 and also functions as an Up/Down control input for Counter 2.
\overline{SS}	I	Slave Select input for the SPI interface.
SDATA	I/O	User selectable, I ² C-Compatible Input/Output pin or SPI Data Input/Output pin.
SCLOCK	I/O	Serial Clock pin for I ² C-Compatible or SPI serial interface clock.
MOSI	I/O	SPI Master Output/Slave Input Data I/O pin for SPI interface.
MISO	I/O	Master Input/Slave Output Data I/O pin for SPI Serial Interface.
DAC0	O	Voltage Output from DAC0.
DAC1	O	Voltage Output from DAC1.
RESET	I	Digital Input. A high level on this pin for 24 master clock cycles while the oscillator is running resets the device.
P3.0–P3.7	I/O	Port 3 is a bidirectional port with internal pull-up resistors. Port 3 pins that have 1s written to them are pulled high by the internal pull-up resistors, and in that state they can be used as inputs. As inputs Port 3 pins being pulled externally low will source current because of the internal pull-up resistors. Port 3 pins also contain various secondary functions which are described below.
RxD	I/O	Receiver Data Input (asynchronous) or Data Input/ Output (synchronous) of serial (UART) port.
TxD	O	Transmitter Data Output (asynchronous) or Clock Output (synchronous) of serial (UART) port.
$\overline{INT0}$	I	Interrupt 0, programmable edge or level triggered Interrupt input, which can be programmed to one of two priority levels. This pin can also be used as a gate control input to Timer 0.
$\overline{INT1}$	I	Interrupt 1, programmable edge or level triggered Interrupt input, which can be programmed to one of two priority levels. This pin can also be used as a gate control input to Timer 1.
T0	I	Timer/Counter 0 Input.
T1	I	Timer/Counter 1 Input.
\overline{CONVST}	I	Active low Convert Start Logic input for the ADC block when the external Convert start function is enabled. A low-to-high transition on this input puts the track/hold into its hold mode and starts conversion.
\overline{WR}	O	Write Control Signal, Logic Output. Latches the data byte from Port 0 into the external data memory.
\overline{RD}	O	Read Control Signal, Logic Output. Enables the external data memory to Port 0.
XTAL2	O	Output of the inverting oscillator amplifier.
XTAL1	I	Input to the inverting oscillator amplifier and input to the internal clock generator circuits.
DGND	G	Digital Ground. Ground reference point for the digital circuitry.
P2.0–P2.7 (A8–A15) (A16–A23)	I/O	Port 2 is a bidirectional port with internal pull-up resistors. Port 2 pins that have 1s written to them are pulled high by the internal pull-up resistors, and in that state they can be used as inputs. As inputs Port 2 pins being pulled externally low will source current because of the internal pull-up resistors. Port 2 emits the high order address bytes during fetches from external program memory and middle and high order address bytes during accesses to the external 24-bit external data memory space.
\overline{PSEN}	O	Program Store Enable, Logic Output. This output is a control signal that enables the external program memory to the bus during external fetch operations. It is active every six oscillator periods <u>except</u> during external data memory accesses. This pin remains high during internal program execution. \overline{PSEN} can also be used to enable serial download mode when pulled low through a resistor on power-up or RESET.

Mnemonic	Type	Function
ALE	O	Address Latch Enable, Logic Output. This output is used to latch the low byte (and middle byte for 24-bit address space accesses) of the address into external memory during normal operation. It is activated every six oscillator periods except during an external data memory access.
$\overline{\text{EA}}$	I	External Access Enable, Logic Input. When held high, this input enables the device to fetch code from internal program memory locations 0000H to 1FFFH. When held low this input enables the device to fetch all instructions from external program memory.
P0.7–P0.0 (A0–A7)	I/O	Port 0 is an 8-bit open drain bidirectional I/O port. Port 0 pins that have 1s written to them float and in that state can be used as high impedance inputs. Port 0 is also the multiplexed low order address and data bus during accesses to external program or data memory. In this application it uses strong internal pull-ups when emitting 1s.

TERMINOLOGY

ADC SPECIFICATIONS

Integral Nonlinearity

This is the maximum deviation of any code from a straight line passing through the endpoints of the ADC transfer function.

The endpoints of the transfer function are zero scale, a point 1/2 LSB below the first code transition and full scale, a point 1/2 LSB above the last code transition.

Differential Nonlinearity

This is the difference between the measured and the ideal 1 LSB change between any two adjacent codes in the ADC.

Offset Error

This is the deviation of the first code transition (0000 . . . 000) to (0000 . . . 001) from the ideal, i.e., +1/2 LSB.

Full-Scale Error

This is the deviation of the last code transition from the ideal AIN voltage (Full Scale – 1.5 LSB) after the offset error has been adjusted out.

Signal to (Noise + Distortion) Ratio

This is the measured ratio of signal to (noise + distortion) at the output of the A/D converter. The signal is the rms amplitude of the fundamental. Noise is the rms sum of all nonfundamental signals up to half the sampling frequency ($f_s/2$), excluding dc.

The ratio is dependent upon the number of quantization levels in the digitization process; the more levels, the smaller the quantization noise. The theoretical signal to (noise + distortion) ratio for an ideal N-bit converter with a sine wave input is given by:

$$\text{Signal to (Noise + Distortion)} = (6.02N + 1.76) \text{ dB}$$

Thus for a 12-bit converter, this is 74 dB.

Total Harmonic Distortion

Total Harmonic Distortion is the ratio of the rms sum of the harmonics to the fundamental.

DAC SPECIFICATIONS

Relative Accuracy

Relative accuracy or endpoint linearity is a measure of the maximum deviation from a straight line passing through the endpoints of the DAC transfer function. It is measured after adjusting for zero error and full-scale error.

Voltage Output Settling Time

This is the amount of time it takes for the output to settle to a specified level for a full-scale input change.

Digital to Analog Glitch Impulse

This is the amount of charge injected into the analog output when the inputs change state. It is specified as the area of the glitch in nV sec.

ADuC812

ADuC812 ARCHITECTURE, MAIN FEATURES

The ADuC812 is a highly integrated high accuracy 12-bit data acquisition system. At its core, the ADuC812 incorporates a high performance 8-bit (8051-Compatible) MCU with on-chip reprogrammable nonvolatile Flash/EE program memory controlling a multichannel (8-input channels), 12-bit ADC.

The chip incorporates all secondary functions to fully support the programmable data acquisition core. These secondary functions include User Flash/EE Data Memory, Watchdog Timer (WDT), Power Supply Monitor (PSM) and various industry-standard parallel and serial interfaces.

ADuC812 MEMORY ORGANIZATION

As with all 8051-compatible devices, the ADuC812 has separate address spaces for Program and Data memory as shown in Figure 1. Also as shown in Figure 1, an additional 640 Bytes of Flash/EE Data Memory are available to the user. The Flash/EE Data Memory area is accessed indirectly via a group of control registers mapped in the Special Function Register (SFR) area.

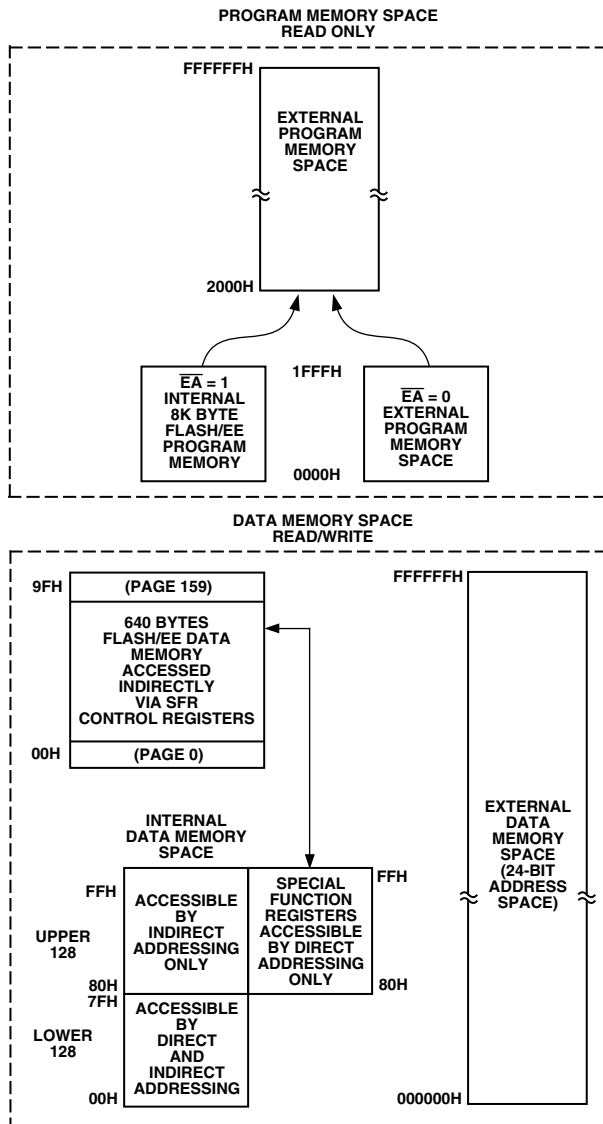

Figure 1. ADuC812 Program and Data Memory Maps

The lower 128 bytes of internal data memory are mapped as shown in Figure 2. The lowest 32 bytes are grouped into four banks of eight registers addressed as R0 through R7. The next 16 bytes (128 bits) above the register banks form a block of bit addressable memory space at bit addresses 00H through 7FH.

The SFR space is mapped in the upper 128 bytes of internal data memory space. The SFR area is accessed by direct addressing only and provides an interface between the CPU and all on-chip peripherals. A block diagram showing the programming model of the ADuC812 via the SFR area is shown in Figure 3.

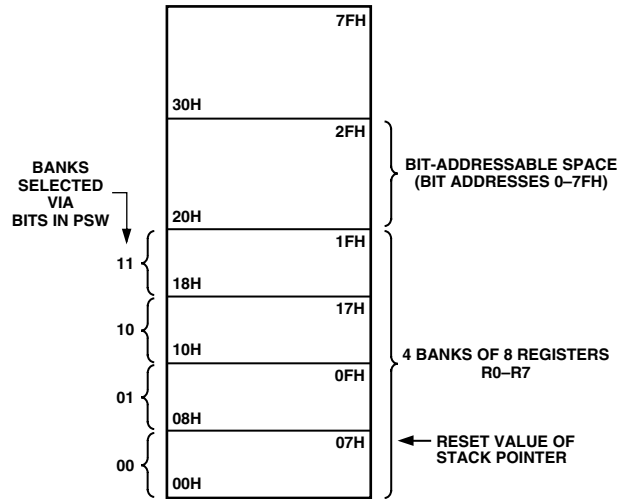

Figure 2. Lower 128 Bytes of Internal RAM

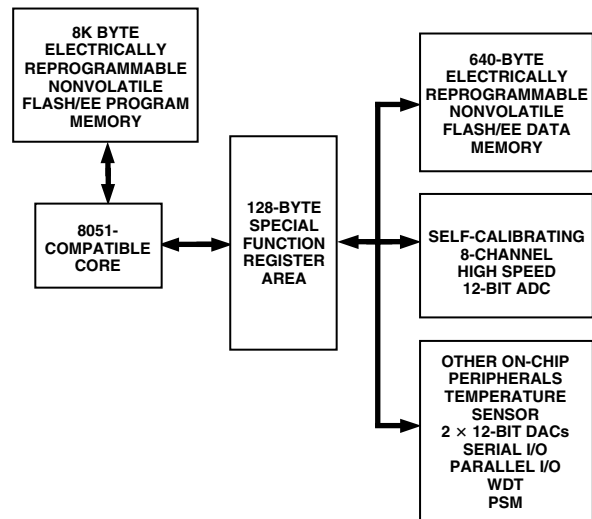

Figure 3. ADuC812 Programming Model

ADC CIRCUIT INFORMATION

General Overview

The ADC conversion block incorporates a 5 μ s, 8-channel, 12-bit, single supply A/D converter. This block provides the user with multichannel mux, track/hold, on-chip reference, calibration features and A/D converter. All components in this block are easily configured via a 3-register SFR interface.

The A/D converter consists of a conventional successive-approximation converter based around a capacitor DAC. The converter accepts an analog input range of 0 to V_{REF} . A high precision, low drift and factory calibrated 2.5 V reference is

provided on-chip. The internal reference may be overdriven via the external V_{REF} pin. This external reference can be in the range 2.3 V to AV_{DD} .

Single step or continuous conversion modes can be initiated in software or, alternatively, by applying a convert signal to an external Pin 25 (\overline{CONVST}). Timer 2 can also be configured to generate a repetitive trigger for ADC conversions. The ADC may be configured to operate in a DMA Mode whereby the ADC block continuously converts and captures samples to an external RAM space without any interaction from the MCU core. This automatic capture facility can extend through a 16 MByte external Data Memory space.

The ADuC812 is shipped with factory programmed calibration coefficients that are automatically downloaded to the ADC on power-up, ensuring optimum ADC performance. The ADC core contains internal Offset and Gain calibration registers, a software calibration routine is provided to allow the user to overwrite the factory programmed calibration coefficients if required, thus minimizing the impact of endpoint errors in the users target system.

A voltage output from an on-chip temperature sensor proportional to absolute temperature can also be routed through the front-end ADC multiplexor (effectively a 9th ADC channel input) facilitating a temperature sensor implementation.

ADC Transfer Function

The analog input range for the ADC is 0 V to V_{REF} . For this range, the designed code transitions occur midway between successive integer LSB values (i.e., 1/2 LSB, 3/2 LSBs, 5/2 LSBs . . . $FS - 3/2$ LSBs). The output coding is straight binary with 1 LSB = $FS/4096$ or $2.5\text{ V}/4096 = 0.61\text{ mV}$ when $V_{REF} = 2.5\text{ V}$. The ideal input/output transfer characteristic for the 0 to V_{REF} range is shown in Figure 4.

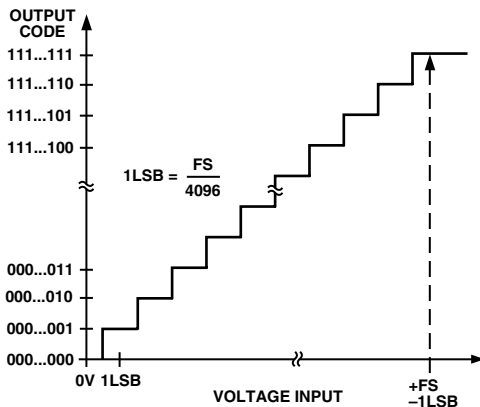

Figure 4. ADuC812 ADC Transfer Function

SFR Interface to ADC Block

The ADC operation is fully controlled via three SFRs, namely:

ADCCON1 – (ADC Control SFR #1)

The ADCCON1 register controls conversion and acquisition times, hardware conversion modes and power-down modes as detailed below.

SFR Address: EFH
 SFR Power-On Default Value: 20H
 Bit Addressable: NO

MD1	MD0	CK1	CK0	AQ1	AQ0	T2C	EXC
-----	-----	-----	-----	-----	-----	-----	-----

Table I. ADCCON1 SFR Bit Designations

Bit Location	Bit Mnemonic	Description															
ADCCON1.7 ADCCON1.6	MD1 MD0	<p>The mode bits (MD1, MD0) select the active operating mode of the ADC as follows:</p> <table border="1"> <thead> <tr> <th>MD1</th> <th>MD0</th> <th>Active Mode</th> </tr> </thead> <tbody> <tr> <td>0</td> <td>0</td> <td>ADC powered down.</td> </tr> <tr> <td>0</td> <td>1</td> <td>ADC normal mode</td> </tr> <tr> <td>1</td> <td>0</td> <td>ADC powered down if not executing a conversion cycle.</td> </tr> <tr> <td>1</td> <td>1</td> <td>ADC standby if not executing a conversion cycle.</td> </tr> </tbody> </table>	MD1	MD0	Active Mode	0	0	ADC powered down.	0	1	ADC normal mode	1	0	ADC powered down if not executing a conversion cycle.	1	1	ADC standby if not executing a conversion cycle.
MD1	MD0	Active Mode															
0	0	ADC powered down.															
0	1	ADC normal mode															
1	0	ADC powered down if not executing a conversion cycle.															
1	1	ADC standby if not executing a conversion cycle.															
ADCCON1.5 ADCCON1.4	CK1 CK0	<p>The ADC clock divide bits (CK1, CK0) select the divide ratio for the master clock used to generate the ADC clock. An ADC conversion will require 16 ADC clocks in addition to the selected number of acquisition clocks (see AQ0/AQ1 below). The divider ratio is selected as follows:</p> <table border="1"> <thead> <tr> <th>CK1</th> <th>CK0</th> <th>MCLK Divider</th> </tr> </thead> <tbody> <tr> <td>0</td> <td>0</td> <td>1</td> </tr> <tr> <td>0</td> <td>1</td> <td>2</td> </tr> <tr> <td>1</td> <td>0</td> <td>4</td> </tr> <tr> <td>1</td> <td>1</td> <td>8</td> </tr> </tbody> </table>	CK1	CK0	MCLK Divider	0	0	1	0	1	2	1	0	4	1	1	8
CK1	CK0	MCLK Divider															
0	0	1															
0	1	2															
1	0	4															
1	1	8															
ADCCON1.3 ADCCON1.2	AQ1 AQ0	<p>The ADC acquisition select bits (AQ1, AQ0) select the time available for the input track/hold amplifier to acquire the input signal and is selected as follows:</p> <table border="1"> <thead> <tr> <th>AQ1</th> <th>AQ0</th> <th>#ADC Clks</th> </tr> </thead> <tbody> <tr> <td>0</td> <td>0</td> <td>1</td> </tr> <tr> <td>0</td> <td>1</td> <td>2</td> </tr> <tr> <td>1</td> <td>0</td> <td>3</td> </tr> <tr> <td>1</td> <td>1</td> <td>4</td> </tr> </tbody> </table> <p>Note: for analog input source impedances of <8 kΩ, the default AQ0/AQ1 selection of 00, i.e., 1 Acquisition Clock will suffice. For source impedances greater than this, it is recommended that you increase the acquisition clock selection to 2, 3 or 4 clocks.</p>	AQ1	AQ0	#ADC Clks	0	0	1	0	1	2	1	0	3	1	1	4
AQ1	AQ0	#ADC Clks															
0	0	1															
0	1	2															
1	0	3															
1	1	4															
ADCCON1.1	T2C	The Timer 2 conversion bit (T2C) is set to enable the Timer 2 overflow bit to be used as the ADC convert start trigger input.															
ADCCON1.0	EXC	The external trigger enable bit (EXC) is set to allow the external Pin 23 (\overline{CONVST}) to be used as the active low convert start input. This input should be an active low pulse (100 ns minimum pulsewidth) at the required sample rate.															

Note: In standby mode the ADC V_{REF} circuits are maintained on, while in powered down mode all ADC peripherals are powered down thus minimizing current consumption. Typical ADC current consumption is 1.6 mA at $V_{DD} = 5\text{ V}$.

ADuC812

ADCCON2 – (ADC Control SFR #2)

The ADCCON2 register controls ADC channel selection and conversion modes as detailed below.

SFR Address: D8H
 SFR Power On Default Value: 00H
 Bit Addressable: YES

ADCI	DMA	CCONV	SCONV	CS3	CS2	CS1	CS0
------	-----	-------	-------	-----	-----	-----	-----

Table II. ADCCON2 SFR Bit Designations

Bit Location	Bit Mnemonic	Description
ADCCON2.7	ADCI	The ADC interrupt bit (ADCI) is set by hardware at the end of a single ADC conversion cycle or at the end of a DMA block conversion. ADCI is cleared by hardware when the PC vectors to the ADC Interrupt Service Routine.
ADCCON2.6	DMA	The DMA mode enable bit (DMA) is set by the user to initiate a pre-configured ADC DMA mode operation. A more detailed description of this mode is given below.
ADCCON2.5	CCONV	The continuous conversion bit (CCONV) is set by the user to initiate the ADC into a continuous mode of conversion. In this mode the ADC starts converting based on the timing and channel configuration already set up in the ADCCON SFRs, the ADC automatically starts an other conversion once a previous conversion cycle has completed.
ADCCON2.4	SCONV	The single conversion bit (SCONV) is set by the user to initiate a single conversion cycle. The SCONV bit is automatically reset to “0” on completion of the single conversion cycle.
ADCCON2.3	CS3	The channel selection bits (CS3-0) allow the user to program the ADC channel selection under software control. Once a conversion is initiated the channel converted will be that pointed to by these channel selection bits. In DMA mode the channel selection is derived from the channel ID written to the external memory.
ADCCON2.2	CS2	
ADCCON2.1	CS1	
ADCCON2.0	CS0	
		CS3 CS2 CS1 CS0 CH#
		0 0 0 0 0
		0 0 0 1 1
		0 0 1 0 2
		0 0 1 1 3
		0 1 0 0 4
		0 1 0 1 5
		0 1 1 0 6
		0 1 1 1 7
		1 0 0 0 Temp Sensor
		1 X X X Other Combinations
		1 1 1 1 DMA STOP

ADCCON3 – (ADC Control SFR #3)

The ADCCON3 register gives user software an indication of ADC busy status.

SFR Address: F5H
 SFR Power On Default Value: 00H
 Bit Addressable: NO

BUSY	RSVD	RSVD	RSVD	CTYP	CAL1	CAL0	CALST
------	------	------	------	------	------	------	-------

Table III. ADCCON3 SFR Bit Designations

Bit Location	Bit Mnemonic	Description
ADCCON3.7	BUSY	The ADC busy status bit (BUSY) is a read-only status bit that is set during a valid ADC conversion or calibration cycle. Busy is automatically cleared by the core at the end of conversion or calibration.
ADCCON3.6	RSVD	ADCCON3.0–3.6 are reserved (RSVD) for internal use. These bits will read as zero and should only be written as zero by user software.
ADCCON3.5	RSVD	
ADCCON3.4	RSVD	
ADCCON3.3	RSVD	
ADCCON3.2	RSVD	
ADCCON3.1	RSVD	
ADCCON3.0	RSVD	

ADC Internal Reference

If the internal reference is being used, both the V_{REF} and C_{REF} pins should be decoupled with 100 nF capacitors to AGND. These decoupling capacitors should be placed very close to the V_{REF} and C_{REF} pins. For specified performance, it is recommended that when using an external reference, this reference should be between 2.3 V and the analog supply AV_{DD} .

If the internal reference is required for use external to the MicroConverter, it should be buffered at the V_{REF} pin and a 100 nF capacitor should be connected from this pin to AGND.

The internal 2.5 V is factory calibrated to an absolute accuracy of $2.5 V \pm 50 mV$. It should also be noted that the internal V_{REF} will remain powered down until either of the DACs or the ADC peripheral blocks are powered on by their respective enable bits.

Calibration

The ADC block also has four associated calibration SFRs. These SFR’s drive calibration logic ensuring optimum performance from the 12-bit ADC at all times. As part of the power-on reset configuration, these SFRs are configured automatically and transparently from factory programmed calibration constants. In many applications use of factory programmed calibration constants will suffice; however, these calibration SFRs may be overwritten by user code to further compensate for system-dependent offset and gain errors.

Calibration Overview

The ADC block incorporates calibration hardware that ensures optimum performance from the ADC at all times. The calibration modes are exercised as part of the ADuC812 internal factory final test routines. The factory calibration results are stored in Flash memory and are automatically downloaded on any power-on-reset event to initialize the ADC calibration registers. In

many applications this autocalibration download function suffices. Alternatively, a device calibration can be easily initiated by user software to compensate for significant changes in operating conditions (CLK frequency, analog input range, reference voltage and supply voltages).

This in-circuit software calibration feature allows the user to remove various system and reference related errors (whether it be internal or external reference) and to make use of the full dynamic range of the ADC by adjusting the analog input range of the part for a specific system. Contact Analog Devices, Inc. for further details on the implementation of the software calibration routine in your applications.

ADC MODES OF OPERATION

Typical Operation

Once configured via the ADCCON 1-3 SFRs (shown previously) the ADC will convert the analog input and provide an ADC 12-bit result word in the ADCDATAH/L SFRs. The top four bits of the ADCDATAH SFR will be written with the channel selection bits to identify the channel result. The format of the ADC 12-bit result word is shown in Figure 5.

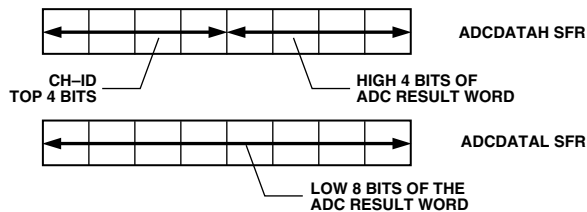

Figure 5. ADC Result Format

ADC DMA Mode

The on-chip ADC has been designed to run at a maximum speed of one sample every 5 μ s (i.e., 200 kHz sampling rate). Therefore, in an interrupt driven routine the user software is required to service the interrupt, read the ADC result and store the result for further post processing, all within 5 μ s otherwise the next ADC sample could be lost. In applications where the ADuC812 cannot sustain the interrupt rate, an ADC DMA Mode is provided.

The ADC DMA Mode is enabled via the DMA enable bit (ADCCON2.6), which allows the ADC to sample continuously as per configuration in ADCCON SFRs. Each sample result is written into an external Static RAM (mapped in the data memory space) without any interaction from the ADuC812 core. This mode ensures the ADuC812 can capture a contiguous sample stream even at full speed ADC update rates.

Before enabling ADC DMA mode the user must first configure the external SRAM to which the ADC samples will be written. This consists of writing the required ADC DMA channels into the channel ID bits (the top four bits) in the external SRAM. A typical preconfiguration of external memory is shown in Figure 6.

Once the external data memory has been preconfigured, the DMA address pointer (DMAP, DMAH and DMAL) SFRs are written. These SFRs should be written with the DMA start address in external memory. In Figure 6, for example, the DMA start address is 000000H. The 3-byte start address should be written in the following order: DMAL, DMAH and DMAP. The end of a DMA table is signified by writing "1111" into the channel selection bits field.

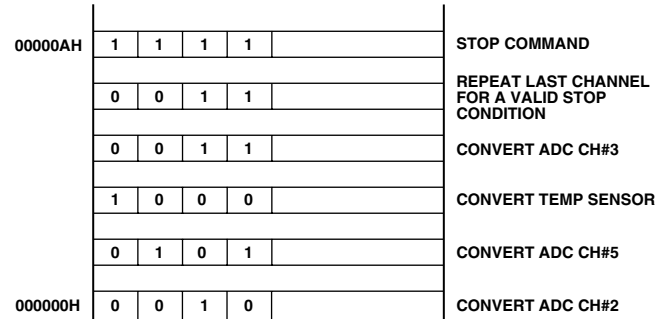

Figure 6. Typical DMA External Memory Preconfiguration

The DMA Enable bit (ADCCON2.6, DMA) can now be set to initiate the DMA conversion and transfer of the results sequentially into external memory. Remember that the DMA mode will only progress if the user has preconfigured the ADC conversion time and trigger modes via the ADCCON1 and 2 SFRs. The end of DMA conversion is signified by the ADC interrupt bit ADCCON2.7.

At the end of ADC DMA Mode, the external data memory contains the new ADC conversion results as shown in Figure 7. It should be noted that the channel selection bits are still present in the result words to identify the individual conversion results.

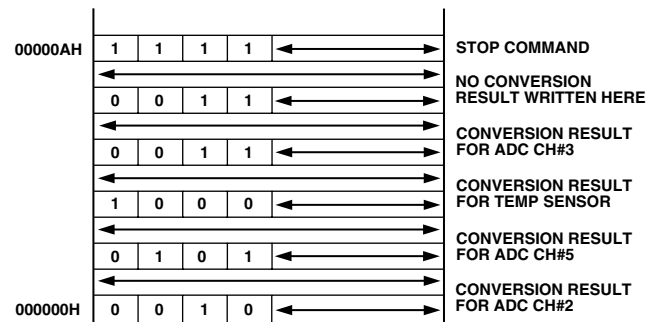

Figure 7. Typical External Memory Configuration Post ADC DMA Operation

Micro Operation during ADC DMA Mode

During ADC DMA mode the MicroConverter core is free to continue code execution, including general housekeeping and communication tasks. However, it should be noted that MCU core accesses to Ports 0 and 2 (which, of course, are being used by the DMA controller) are gated "OFF" during ADC DMA mode of operation. This means that even though the instruction that accesses the external Ports 0 or 2 will appear to execute, no data will be seen at these external port pins as a result.

The MicroConverter core is interrupted once the requested block of DMA data has been captured and written to external memory allowing the service routine for this interrupt to post-process the data without any real time, timing constraints.

SFR Interface to the DAC Block

The ADuC812 incorporates two 12-bit DACs on-chip. DAC operation is controlled via a single control special function register and four data special function registers, namely:

- DAC0L/DAC1L** – Contains the lower 8-bit DAC byte.
- DAC0H/DAC1H** – Contains the high 4-bit DAC byte.
- DACCON** – Contains general purpose control bits required for DAC0 and DAC1 operation.

ADuC812

In normal mode of operation each DAC is updated when the low DAC nibble (DACxL) SFR is written. Both DACs can be updated simultaneously using the SYNC bit in the DACCON SFR.

In 8-bit mode of operation, the 8-bit byte written to the DACxL registers is automatically routed to the top 8 bits of each 12-bit DAC. The bit designations of the DACCON SFR are shown below in Table IV.

SFR Address: FDH
 SFR Power On Default Value: 04H
 Bit Addressable: NO

MODE	RNG1	RNG0	CLR1	CLR0	SYNC	PD1	PD0
------	------	------	------	------	------	-----	-----

Table IV. DACCON SFR Bit Designations

Bit Location	Bit Mnemonic	Description
DACCON.7	MODE	The DAC MODE bit sets the overriding operating mode for both DACs. Set to "1" = 8-bit mode (Write 8 bits to DACxL SFR). Set to "0" = 12-bit mode.
DACCON.6	RNG1	DAC1 range select bit. Set to "1" = DAC1 range 0–V _{DD} . Set to "0" = DAC1 range 0–V _{REF} .
DACCON.5	RNG0	DAC0 range select bit. Set to "1" = DAC0 range 0–V _{DD} . Set to "0" = DAC0 range 0–V _{REF} .
DACCON.4	CLR1	DAC1 clear bit. Set to "0" = DAC1 output forced to 0 V. Set to "1" = DAC1 output normal.
DACCON.3	CLR0	DAC0 clear bit. Set to "0" = DAC0 output forced to 0 V. Set to "1" = DAC0 output normal.
DACCON.2	SYNC	DAC0/1 update synchronization bit. When set to "1" the DAC outputs update as soon as the DACxL SFRs are written. The user can simultaneously update both DACs by first updating the DACxL/H SFRs while SYNC is "0." Both DACs will then update simultaneously when the SYNC bit is set to "1."
DACCON.1	PD1	DAC1 Power-Down Bit. Set to "1" = Power-On DAC1. Set to "0" = Power-Off DAC1.
DACCON.0	PD0	DAC0 Power-Down Bit. Set to "1" = Power-On DAC0. Set to "0" = Power-Off DAC0.

NONVOLATILE FLASH MEMORY

Flash Memory Overview

The ADuC812 incorporates Flash memory technology on-chip to provide the user with a nonvolatile, in-circuit reprogrammable, code and data memory space.

Flash memory is the newest type of nonvolatile memory technology and is based on a single transistor cell architecture. This technology is basically an outgrowth of EPROM technology and was developed through the late 1980s.

Flash memory takes the flexible in-circuit reprogrammable features of EEPROM and combines them with the space efficient/density features of EPROM (see Figure 8).

Because Flash technology is based on a single transistor cell architecture, a Flash memory array, like EPROM can be implemented to achieve the space efficiencies or memory densities required by a given design.

Like EEPROM, Flash memory can be programmed in-system at a byte level, although it must be erased first; the erase being performed in sector blocks. Thus, Flash memory is often and more correctly referred to as Flash/EE memory.

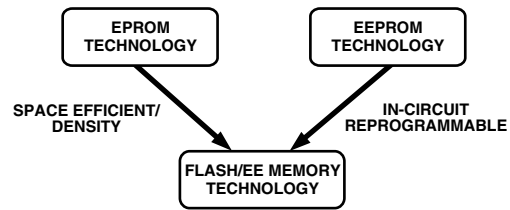

Figure 8. Flash Memory Development

Overall, Flash/EE memory represents a step closer towards the ideal memory device that includes nonvolatility, in-circuit programmability, high density and low cost. Incorporated in the ADuC812, Flash/EE memory technology allows the user to update program code space in-circuit without the need to replace one-time programmable (OTP) devices at remote operating nodes.

Flash/EE Memory and the ADuC812

The ADuC812 provides two arrays of Flash/EE memory for user applications.

8K bytes of Flash/EE Program space are provided on-chip to facilitate code execution without any external discrete ROM device requirements. The program memory can be programmed using conventional third party memory programmers. This array can also be programmed in-circuit, using the serial download mode provided.

A 640-Byte Flash/EE Data Memory space is also provided on-chip. This may be used by the user as a general purpose non-volatile scratchpad area. User access to this area is via a group of six SFRs. This space can be programmed at a byte level, although it must first be erased in 4-byte sectors.

Using the Flash/EE Program Memory

This 8K Byte Flash/EE Program Memory array is mapped into the lower 8K bytes of the 64K bytes program space addressable by the ADuC812 and will be used to hold user code in typical applications.

The program memory array can be programmed in one of two modes, namely:

Serial Downloading (In-Circuit Programming)

As part of its factory boot code, the ADuC812 facilitates serial code download via the standard UART serial port. Serial download mode is automatically entered on power-up if the external pin, PSEN, is pulled low through an external resistor as shown in Figure 9. Once in this mode, the user can download code to the program memory array while the device is sited in its target application hardware. A PC serial download executable is provided as part of the ADuC812 QuickStart development system.

The Serial Download protocol is detailed in a MicroConverter Applications Note available from ADI.

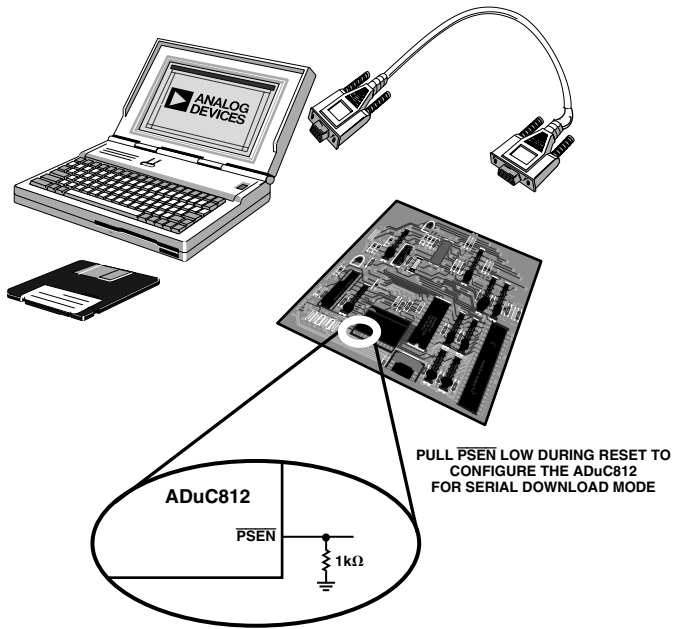

Figure 9. Flash/EE Memory Serial Download Mode Programming

Parallel Programming

The parallel programming mode is fully compatible with conventional third party Flash or EEPROM device programmers. A block diagram of the external pin configuration required to support parallel programming is shown in Figure 10. In this mode Ports P0, P1 and P2 operate as the external data and address bus interface, ALE operates as the Write Enable strobe and Port P3 is used as a general configuration port that configures the device for various program and erase operations during parallel programming. The high voltage (12 V) supply required for Flash programming is generated using on-chip charge pumps to supply the high voltage program lines.

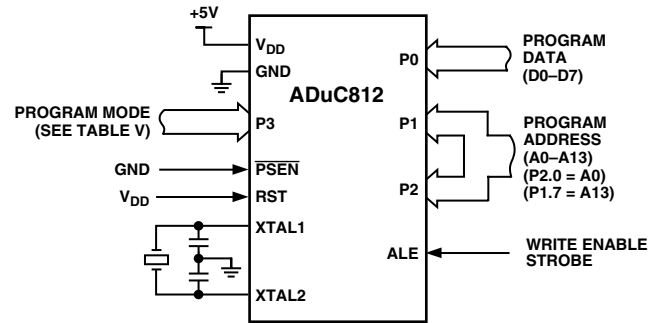

Figure 10. Flash/EE Memory Parallel Programming

Table V shows the normal parallel programming modes that can be configured using Port 3 bits.

Table V. Flash Memory Parallel Programming Modes

Port Pins	(P3.0–P3.7)							Programming Mode	
	.7	.6	.5	.4	.3	.2	.1		.0
1	X	X	X	0	0	0	0	1	Erase Flash Program Erase Flash User
1	X	X	X	0	0	1	1	1	Read Manufacture and Chip ID
1	X	X	X	0	1	0	0	1	Program Byte
1	X	X	X	0	1	1	1	1	Read Byte
1	X	X	X	1	0	0	0	1	Reserved
1	X	X	X	1	0	1	1	1	Reserved
Any Other Code									Redundant

Using the Flash/EE Data Memory

The user Flash/EE data memory array consists of 640 bytes that are configured into 160 (00H to 9FH), 4-byte pages as shown in Figure 11.

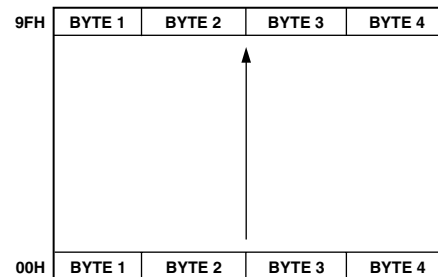

Figure 11. User Flash/EE Memory Configuration

As with other user peripherals the interface to this memory space is via a group of registers mapped in the SFR space. A group of four data registers (EDATA1-4) are used to hold the 4-byte page data just accessed. EADRL is used to hold the 8-bit address of the page to be accessed. Finally, ECON is an 8-bit control register that may be written with one of five Flash/EE memory access commands to enable various read, write, erase and verify modes.

ADuC812

A block diagram of the SFR registered interface to the User Flash/EE Memory array is shown in Figure 12.

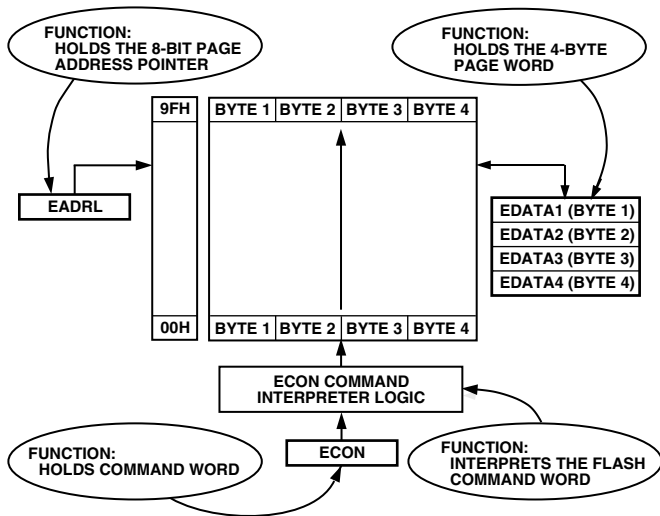

Figure 12. User Flash/EE Memory Control and Configuration

ECON—Flash/EE Memory Control SFR

This SFR acts as a command interpreter and may be written with one of five command modes to enable various read, program and erase cycles as detailed in Table VI:

Table VI. ECON—Flash/EE Memory Control Register Command Modes

Command Byte	Command Mode
01H	READ COMMAND Results in four bytes being read into EDATA 1–4 from memory page location contained in EADRL .
02H	WRITE COMMAND Results in four bytes (EDATA 1–4) being written to memory page location in EADRL. This write command assumes the designated “write” page has been pre-erased.
03H	RESERVED COMMAND “DO NOT USE”
04H	VERIFY COMMAND Allows the user to verify if data in EDATA 1–4 is contained in page location designated by EADRL. A subsequent read of the ECON SFR will result in a “zero” being read if the verification is valid, a nonzero value will be read to indicate an invalid verification.
05H	ERASE COMMAND Results in an erase of the 4-byte page designated in EADRL.
06H	ERASE-ALL COMMAND Results in erase of the full user memory 160-page (640 bytes) array.
07H to FFH	RESERVED COMMANDS Commands reserved for future use.

Flash/EE Memory Write and Erase Times

The typical program/erase times for the User Flash/EE Memory are:

- Erase Full Array (640 Bytes) – 20 ms
- Erase Single Page (4 Bytes) – 20 ms
- Program Page (4 Bytes) – 250 μs
- Read Page (4 Bytes) – Within Single Instruction Cycle

Using the Flash/EE Memory Interface

As with all Flash/EE memory architectures, the array can be programmed in system at a byte level, although it must be erased first; the erasure being performed in page blocks (4-byte pages in this case).

A typical access to the Flash/EE array will involve setting up the page address to be accessed in the EADRL SFR, configuring the EDATA1-4 with data to be programmed to the array (the EDATA SFRs will not be written for read accesses) and finally writing the ECON command word which initiates one of the five modes shown in Table VI.

It should be noted that a given mode of operation is initiated as soon as the command word is written to the ECON SFR. At this time the core microcontroller operation on the ADuC812 is idled until the requested Program/Read or Erase mode is completed.

In practice, this means that even though the Flash/EE memory mode of operation is typically initiated with a 2 machine cycle MOV instruction (to write to the ECON SFR), the next instruction will not be executed until the Flash/EE operation is complete (250 μs or 20 ms later). This means that the core will not respond to Interrupt requests until the Flash/EE operation is complete, although the core peripheral functions like Counter/Timers will continue to count and time as configured throughout this pseudo-idle period.

ERASE-ALL

Although the 640-byte User Flash/EE array is shipped from the factory pre-erased, i.e., Byte locations set to FFH, it is nonetheless good programming practice to include an erase-all routine as part of any configuration/setup code running on the ADuC812.

An “ERASE-ALL” command consists of writing “06H” to the ECON SFR, which initiates an erase of all 640 byte locations in the Flash/EE array. This command coded in 8051 assembly would appear as:

```
MOV ECON, #06H      ; Erase all Command
                    ; 20 ms Duration
```

PROGRAM A BYTE

In general terms, a byte in the Flash/EE array can only be programmed if it has previously been erased. To be more specific, a byte can only be programmed if it already holds the value FFH. Because of the Flash/EE architecture this erasure must happen at a page level, therefore a minimum of four bytes (1 page) will be erased when an erase command is initiated.

A more specific example of the Program-Byte process is shown graphically in Figure 13. In this example the user will write F3H into the second byte on Page 03H of the User Flash/EE Memory space.

However, Page 03H already contains four bytes of valid data, and as the user is only required to modify one of these bytes, the full page must be first read so that this page can then be erased without the existing data being lost.

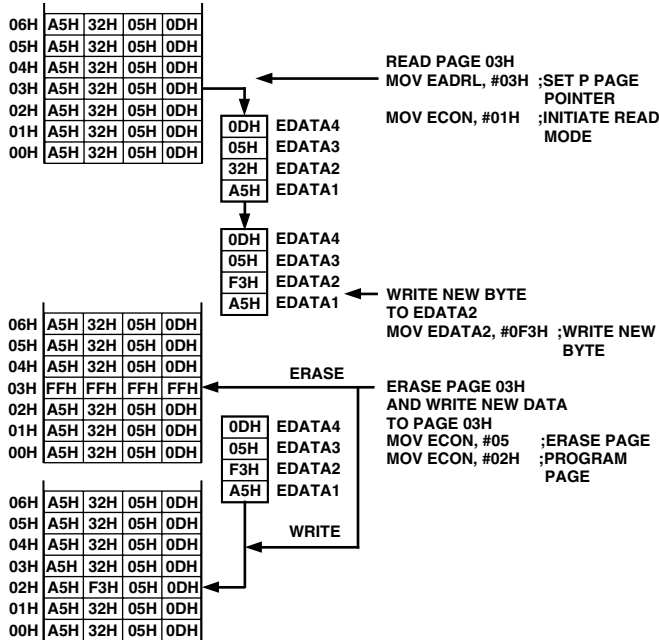

Figure 13. User Flash/EE Memory Program Byte Example

The new byte is then written to the EDATA2 SFR, followed by an ERASE cycle that will ensure this page is erased before the new page data EDATA1-4 is written back into memory.

If the user attempts to initiate a PROGRAM cycle (ECON set to 02H) without an ERASE cycle (ECON set to 05H), then only bit locations set to a “1” would be modified, i.e., the Flash/EE memory byte location must be pre-erased to allow a valid write access to the array. It should also be noted that the time durations for an ERASE-ALL command (640 bytes) and that for an ERASE page command (four bytes) are identical, i.e., 20 ms.

This example coded in 8051 assembly would appear as :

```

MOV     EADRL, #03H      ; Set Page Pointer
MOV     ECON, #01H      ; Read Page Command
MOV     EDATA2, #0F3H   ; Write New Byte
MOV     ECON, #02H      ; Erase Page Command
MOV     ECON, #05H      ; Program Page Command
    
```

INTERRUPT SYSTEM

The ADuC812 provides nine interrupt sources with two priority levels. Interrupt priority within a given level is shown in descending order of priority in Figure 14, which gives a general overview of the interrupt sources and illustrates the request and control flags. The interrupt vector addresses for corresponding interrupts are also included in Table VII.

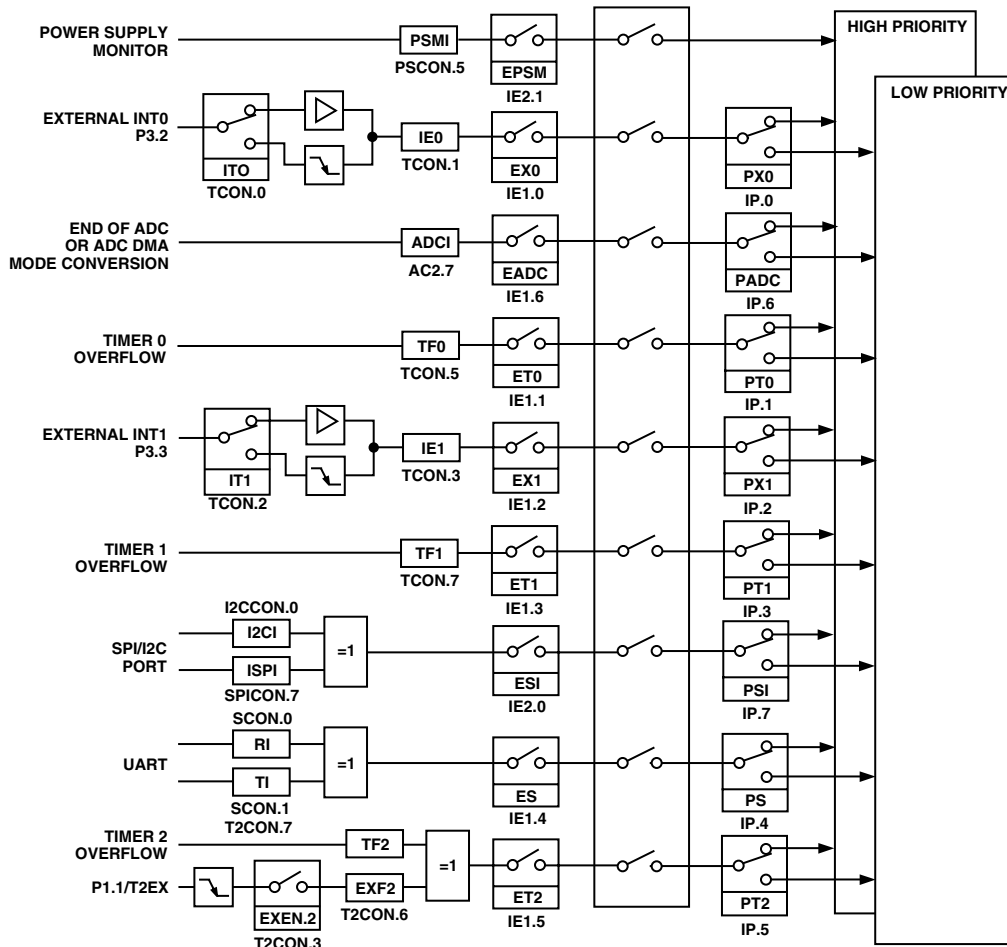

Figure 14. Interrupt Request Sources

ADuC812

Table VII. Interrupt Vector Addresses

Interrupt	Interrupt Name	Interrupt Vector Address	Priority Within Level
PSMI	Power Supply Monitor	43H	1
IE0	External $\overline{\text{INT0}}$	03H	2
ADCI	End of ADC Conversion	33H	3
TF0	Timer 0 Overflow	0BH	4
IE1	External $\overline{\text{INT1}}$	13H	5
TF1	Timer 1 Overflow	1BH	6
I2CI/ISPI	Serial Interrupt	3BH	7
RI/TI	UART Interrupt	23H	8
TF2/EXF2	Timer 2 Interrupt	2BH	9

Use of Interrupts

To use any of the interrupts on the ADuC812, the following three steps must be taken.

1. Locate the interrupt service routine at the corresponding Vector Address of that interrupt. See Table VII above.
2. Set the EA (enable all) bit in the IE SFR to “1.”
3. Set the corresponding individual interrupt bit in the IE or IE2 SFR to “1.”

Three SFRs are used to enable and set priority for the various interrupts. The bit designations of these SFRs are shown in Tables VIII, IX and X. It should be noted that while IE and IP SFRs are bit addressable, IE2 is byte addressable only.

IE – (Interrupt Enable SFR)

The IE register enables the interrupt system and seven interrupt sources.

SFR Address: A8H
 SFR Power On Default Value: 00H
 Bit Addressable: YES

EA	EADC	ET2	ES	ET1	EX1	ET0	EX0
----	------	-----	----	-----	-----	-----	-----

Table VIII. Interrupt Enable (IE) SFR Bit Designations

Bit Location	Bit Mnemonic	Description
IE.7	EA	The Global Interrupt Enable bit (EA) must be set to “1” before any interrupt source will be recognized by the core. EA is set to “0” to disable all interrupts.
IE.6	EADC	The ADC Interrupt Enable bit (EADC) is set to “1” to enable the ADC interrupt.
IE.5	ET2	The Timer 2 Overflow Interrupt Enable bit (ET2) is set to “1” to enable the Timer 2 interrupt.
IE.4	ES	The UART Serial Port Interrupt Enable bit (ES) is set to “1” to enable the UART Serial Port Interrupt.
IE.3	ET1	The Timer 1 Overflow Interrupt Enable bit (ET1) is set to “1” to enable the Timer 1 interrupt.
IE.2	EX1	The INT1 Interrupt Enable bit (EX1) is set to “1” to enable the external INT1 interrupt.

Bit Location	Bit Mnemonic	Description
IE.1	ET0	The Timer 0 Overflow Interrupt Enable bit (ET0) is set to “1” to enable the Timer 0 interrupt.
IE.0	EX0	The INT0 Interrupt Enable bit (EX0) is set to “1” to enable the external INT0 interrupt

IE2 – (Interrupt Enable 2 SFR)

The IE2 register enables two additional interrupt sources.

SFR Address: A9H
 SFR Power On Default Value: 00H
 Bit Addressable: NO

NU	NU	NU	NU	NU	NU	EPSM	ESI
----	----	----	----	----	----	------	-----

Table IX. Interrupt Enable 2 (IE2) SFR Bit Designations

Bit Location	Bit Mnemonic	Description
IE2.7	NU	Not Used
IE2.6	NU	Not Used
IE2.5	NU	Not Used
IE2.4	NU	Not Used
IE2.3	NU	Not Used
IE2.2	NU	Not Used
IE2.1	EPSM	The Power Supply Monitor Interrupt enable bit is set to “1” to enable the PSM Interrupt.
IE2.0	ESI	The SPI/I ² C Interrupt Enable bit (ESI) is set to “1” to enable the SPI or I ² C interrupt.

IP – (Interrupt Priority SFR)

The IP register sets one of two main priority levels for the various interrupt sources. Set the corresponding bit to “1” to configure interrupt as high priority and to “0” to configure interrupt as low priority.

SFR Address: B8H
 SFR Power On Default Value: 00H
 Bit Addressable: YES

PS1	PADC	PT2	PS	PT1	PX1	PT0	PX0
-----	------	-----	----	-----	-----	-----	-----

Table X. Interrupt Priority (IP) SFR Bit Designations

Bit Location	Bit Mnemonic	Description
IP.7	PSI	Sets SPI/I ² C Interrupt Priority
IP.6	PADC	Sets ADC Interrupt Priority
IP.5	PT2	Sets Timer 2 Interrupt Priority
IP.4	PS	Sets UART Serial Port Interrupt Priority
IP.3	PT1	Sets Timer 1 Interrupt Priority
IP.2	PX1	Sets External INT1 Interrupt Priority
IP.1	PT0	Sets Timer 0 Interrupt Priority
IP.0	PX0	Sets External INT0 Interrupt Priority

ON-CHIP PERIPHERALS

The following sections give a brief overview of the various secondary peripherals also available on-chip. A quick reference to the various SFR configuration registers used to control these peripheral functions is given on the following pages.

PARALLEL I/O PORTS 0–3

The ADuC812 uses four general purpose data ports to exchange data with external devices. In addition to performing general purpose I/O, some ports are capable of external memory operations; others are multiplexed with an alternate function for the peripheral features on the device. In general, when a peripheral sharing a port pin is enabled, that pin may not be used as a general purpose I/O pin.

Ports 0, 2 and 3 are bidirectional while Port 1 is an input only port. All ports contain an output latch and input buffer, the I/O Ports will also contain an output driver. Read and Write accesses to Port 0–3 pins are performed via their corresponding special function registers.

Port pins on Ports 0, 2 and 3 can be independently configured as digital inputs or digital outputs via the corresponding port SFR bits. Port 1 pins however, can be configured as digital inputs or analog inputs only, Port 1 digital output capability is not supported on this device.

SERIAL I/O PORTS

UART Interface

The serial port is full duplex, meaning it can simultaneously transmit and receive. It is also receive-buffered, meaning it can commence reception of a second byte before a previously received byte has been read from the receive register. However, if the first byte still hasn't been read by the time reception of the second byte is complete, one of the bytes will be lost.

The physical interface to the serial data network is via Pins RxD(P3.0) and TxD(P3.1) and the serial port can be configured into one of four modes of operation.

Serial Peripheral Interface (SPI)

The Serial Peripheral Interface (SPI) is an industry standard synchronous serial interface that allows eight bits of data to be synchronously transmitted and received simultaneously. The system can be configured for Master or Slave operation.

I²C-Compatible Serial Interface

The ADuC812 supports a 2-wire serial interface mode that is I²C-compatible. This interface can be configured to be a Software Master or Hardware Slave and is multiplexed with the SPI serial interface port.

TIMERS/COUNTERS

The ADuC812 has three 16-bit Timer/Counters, namely: Timer 0, Timer 1 and Timer 2. The Timer/Counter hardware has been included on-chip to relieve the processor core of the overhead inherent in implementing timer/counter functionality in software. Each Timer/Counter consists of two 8-bit registers THx and TLx (x = 0, 1 and 2). All three can be configured to operate either as timers or event counters.

In “Timer” function, the TLx register is incremented every machine cycle. Thus one can think of it as counting machine cycles. Since a machine cycle consists of 12 oscillator periods, the maximum count rate is 1/12 of the oscillator frequency.

In “Counter” function, the TLx register is incremented by a 1-to-0 transition at its corresponding external input pin, T0, T1 or T2.

ON-CHIP MONITORS

The ADuC812 integrates two on-chip monitor functions to minimize code or data corruption during catastrophic programming or other external system faults. Again, both monitor functions are fully configurable via the SFR space.

WATCHDOG TIMER

The purpose of the watchdog timer is to generate a device reset within a reasonable amount of time if the ADuC812 enters an erroneous state, possibly due to a programming error, electrical noise or RFI. The Watchdog function can be permanently disabled by clearing WDE (Watchdog Enable) bit in the Watchdog Control (WDCON) SFR. When enabled, the watchdog circuit will generate a system reset if the user program fails to refresh the watchdog within a predetermined amount of time. The watchdog reset interval can be adjusted via the SFR prescale bits from 16 to 204 ms.

POWER SUPPLY MONITOR

The Power Supply Monitor generates an interrupt when the analog (AV_{DD}) or digital (DV_{DD}) power supplies to the ADuC812 drop below one of five user-selectable voltage trip points from 2.6 V to 4.6 V. The interrupt bit will not be cleared until the power supply has returned above the trip point for at least 256 ms.

This monitor function ensures that the user can save working registers to avoid possible data corruption due to the low supply condition, and that code execution will not resume until a “safe” supply level has been well established. The supply monitor is also protected against spurious glitches triggering the interrupt circuit.

QuickStart DEVELOPMENT SYSTEM

The QuickStart Development System is a full featured, low cost development tool suite supporting the ADuC812. The system consists of the following PC-based (Win95-compatible) hardware and software development tools.

Code Development: Full Assembler and C Compiler
(2K Code Limited)

Code Functionality: ADSIM812, Windows Code Simulator

Code Download: FLASH/EE UART-Serial Downloader

Code Debug: Serial Port Debugger

Misc: System includes CD-ROM documentation, power supply and serial port cable.

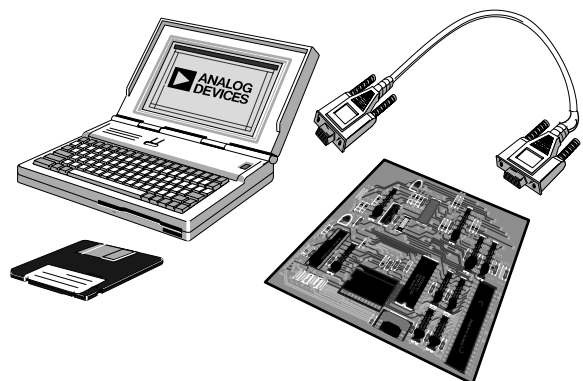

Figure 15. Typical QuickStart System Configuration

ADuC812

SPECIAL FUNCTION REGISTERS

All registers except the program counter and the four general purpose register banks, reside in the special function register (SFR) area. The SFR registers include control, configuration and data registers that provide an interface between the CPU and other on-chip peripherals.

Figure 16 shows a full SFR memory map and SFR contents on Reset; NOT USED indicates unoccupied SFR locations. Unoccupied locations in the SFR address space are not implemented; i.e., no register exists at this location. If an unoccupied location is read, an unspecified value is returned. SFR locations reserved for on-chip testing are shaded (RESERVED) and should not be accessed by user software.

ISPI FFH 0	WCOL FEH 0	SPE FDH 0	SP1M FCH 0	CPOL FBH 0	CPHA FAH 0	SPR1 F9H 0	SPR0 F8H 0	BITS	SPICON ¹ F8H 00H	DAC0L F9H 00H	DAC0H FAH 00H	DAC1L FBH 00H	DAC1H FCH 00H	DACCON FDH 04H	RESERVED	NOT USED
F7H 0	F6H 0	F5H 0	F4H 0	F3H 0	F2H 0	F1H 0	F0H 0	BITS	B ¹ F0H 00H	ADCOFSL ³ F1H 00H	ADCOFSH ³ F2H 20H	ADCGAINL ³ F3H 00H	ADCGAINH ³ F4H 00H	ADCCON3 F5H 00H	RESERVED	SPIDAT F7H 00H
MDO EFH 0	MDE EEH 0	MCO EDH 0	MDI ECH 0	I2CM EBH 0	I2CRS EAH 0	I2CTX E9H 0	I2CI E8H 0	BITS	I2CCON ¹ E8H 00H	RESERVED	RESERVED	RESERVED	RESERVED	RESERVED	RESERVED	ADCCON1 EFH 20H
E7H 0	E6H 0	E5H 0	E4H 0	E3H 0	E2H 0	E1H 0	E0H 0	BITS	ACC ¹ E0H 00H	RESERVED	RESERVED	RESERVED	RESERVED	RESERVED	RESERVED	RESERVED
ADC1 DFH 0	DMA DEH 0	CCONV DDH 0	SCONV DCH 0	CS3 DBH 0	CS2 DAH 0	CS1 D9H 0	CS0 D8H 0	BITS	ADCCON2 ¹ D8H 00H	ADCCON2 ¹ D9H 00H	ADCCON2 ¹ DAH 00H	RESERVED	RESERVED	RESERVED	RESERVED	PSMCON DFH DCH
CY D7H 0	AC D6H 0	F0 D5H 0	RSI D4H 0	RS0 D3H 0	OV D2H 0	FI D1H 0	P D0H 0	BITS	PSW ¹ D0H 00H	RESERVED	DMAL D2H 00H	DMAH D3H 00H	DMAP D4H 00H	RESERVED	RESERVED	RESERVED
TF2 CFH 0	EXF2 CEH 0	RCLK CDH 0	TCLK CCH 0	XEN CBH 0	TR2 CAH 0	CNT2 C9H 0	CAP2 C8H 0	BITS	T2CON ¹ C8H 00H	RESERVED	RCAP2L CAH 00H	RCAP2H CBH 00H	TL2 CCH 00H	TH2 CDH 00H	RESERVED	RESERVED
PRE2 C7H 0	PRE1 C6H 0	PRE0 C5H 0	NOT USED C4H 0	WDR1 C3H 0	WDR2 C2H 0	WDS C1H 0	WDE C0H 0	BITS	WDCON ¹ C0H 00H	NOT USED	NOT USED	NOT USED	ETIM3 C4H C9H	RESERVED	EDARL C6H 00H	RESERVED
PS1 BFH 0	PADC BEH 0	PT2 BDH 0	PS BCH 0	PT1 BBH 0	PX1 BAH 0	PT0 B9H 0	PX0 B8H 0	BITS	IP ¹ B8H 00H	ECON B9H 00H	ETIM1 BAH 52H	ETIM2 BBH 04H	EDATA1 BCH 00H	EDATA2 BDH 00H	EDATA3 BEH 00H	EDATA4 BFH 00H
RD B7H 1	WR B6H 1	T1 B5H 1	T0 B4H 1	INT1 B3H 1	INT0 B2H 1	TxD B1H 1	RxD B0H 1	BITS	P3 ¹ B0H FFH	NOT USED	NOT USED	NOT USED	NOT USED	NOT USED	NOT USED	NOT USED
EA AFH 0	EADC AEH 0	ET2 ADH 0	ES ACH 0	ET1 ABH 0	EX1 AAH 0	ET0 A9H 0	EX0 A8H 0	BITS	IE ¹ A8H 00H	IE2 A9H 00H	NOT USED	NOT USED	NOT USED	NOT USED	NOT USED	NOT USED
A7H	A6H	A5H 1	A4H 1	A3H 1	A2H 1	A1H 1	A0H 1	BITS	P2 ¹ A0H FFH	NOT USED	NOT USED	NOT USED	NOT USED	NOT USED	NOT USED	NOT USED
SM0 9FH 0	SM1 9EH 0	SM2 9DH 0	REN 9CH 0	TB8 9BH 0	RB8 9AH 0	T1 99H 0	R1 98H 0	BITS	SCON ¹ 98H 00H	SBUF 99H 00H	I2CDAT 9AH 00H	I2CADD 9BH 00H	NOT USED	NOT USED	NOT USED	NOT USED
97H 0	96H 0	SS/ 95H 0	94H 0	93H 0	92H 0	T2EX 91H 0	T2 90H 0	BITS	P1 ^{1,2} 90H FFH	NOT USED	NOT USED	NOT USED	NOT USED	NOT USED	NOT USED	NOT USED
TF1 8FH 0	TR1 8EH 0	TF0 8DH 0	TR0 8CH 0	IE1 8BH 0	IT1 8AH 0	IE0 89H 0	IT0 88H 0	BITS	TCON ¹ 88H 00H	TMOD 89H 00H	TL0 8AH 00H	TL1 8BH 00H	TH0 8CH 00H	TH1 8DH 04H	NOT USED	NOT USED
87H 1	86H 1	85H 1	84H 1	83H 1	82H 1	81H 1	80H 1	BITS	P0 ¹ 80H FFH	SP 81H 07H	DPL 82H 00H	DPH 83H 00H	DPP 84H 00H	RESERVED	RESERVED	PCON 87H 00H

SFR MAP KEY:

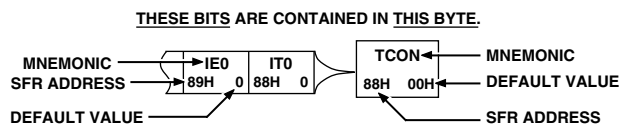

SFR NOTES:

¹SFRs WHOSE ADDRESS ENDS IN 0H OR 8H ARE BIT ADDRESSABLE.

²THE PRIMARY FUNCTION OF PORT1 IS AS AN ANALOG INPUT PORT, THEREFORE, TO ENABLE THE DIGITAL SECONDARY FUNCTIONS ON THESE PORT PINS, WRITE A '0' TO THE CORRESPONDING PORT 1 SFR BIT.

³CALIBRATION COEFFICIENTS ARE PRECONFIGURED ON POWER-UP TO FACTORY CALIBRATED VALUES.

Figure 16. Special Function Register Locations and Reset Values

<p>IE INTERRUPT ENABLE REGISTER #1</p> <p>EA ENABLE INTERRUPTS (0 = ALL INTERRUPTS DISABLED)</p> <p>EADC ENABLE ADC1 (ADC INTERRUPT)</p> <p>ET2 ENABLE TF2/EXF2 (TIMER2 OVERFLOW INTERRUPT)</p> <p>ES ENABLE RI/TI (SERIAL PORT INTERRUPT)</p> <p>ET1 ENABLE TF1 (TIMER1 OVERFLOW INTERRUPT)</p> <p>EX1 ENABLE IE1 (EXTERNAL INTERRUPT 1)</p> <p>ET0 ENABLE TFO (TIMER0 OVERFLOW INTERRUPT)</p> <p>EX0 ENABLE IE0 (EXTERNAL INTERRUPT 0)</p>	<p>TCON TIMER CONTROL REGISTER</p> <p>TF1 TIMER1 OVERFLOW FLAG (AUTO CLEARED ON VECTOR TO ISR)</p> <p>TR1 TIMER1 RUN CONTROL (0 = OFF, 1 = RUN)</p> <p>TF0 TIMER0 OVERFLOW FLAG (AUTO CLEARED ON VECTOR TO ISR)</p> <p>TR0 TIMER0 RUN CONTROL (0 = OFF, 1 = RUN)</p> <p>IE1 EXTERNAL INT1 FLAG (AUTO CLEARED ON VECTOR TO ISR)</p> <p>IT1 IE1 TYPE (0 = LEVEL TRIG, 1 = EDGE TRIG)</p> <p>IE0 EXTERNAL INT0 FLAG (AUTO CLEARED ON VECTOR TO ISR)</p> <p>IT0 IE0 TYPE (0 = LEVEL TRIG, 1 = EDGE TRIG)</p>	<p>SPICON SPI CONTROL REGISTER</p> <p>ISPI SPI INTERRUPT (SET AT END OF SPI TRANSFER)</p> <p>WCOL WRITE COLLISION ERROR FLAG</p> <p>SPE SPI ENABLE (0 = DISABLE, ALSO ENABLES SPI)</p> <p>SPIM MASTER MODE SELECT (0 = SLAVE)</p> <p>CPOL CLOCK POLARITY SELECT (0 = SCLK IDLES LOW)</p> <p>CPHA CLOCK PHASE SELECT (0 = LEADING EDGE LATCH)</p> <p>SPR1 SPI BITRATE SELECT BITS</p> <p>SPR0 BITRATE = $F_{Osc} / [4, 8, 32, 64]$</p>
<p>IE2 INTERRUPT ENABLE REGISTER #2</p> <p>IE2.1 ENABLE PSMI (POWER SUPPLY MONITOR INTERRUPT)</p> <p>IE2.0 ENABLE ISPI/I2CI (SERIAL INTERFACE INTERRUPT)</p>	<p>TH0, TL0 TIMER0 REGISTERS</p> <p>TH1, TL1 TIMER1 REGISTERS</p>	<p>SPIDAT SPI DATA REGISTER</p>
<p>IP INTERRUPT PRIORITY REGISTER</p> <p>PSI PRIORITY OF IS/ISPI (SERIAL INTERFACE INTERRUPT)</p> <p>PADC PRIORITY OF ADC1 (ADC INTERRUPT)</p> <p>PT2 PRIORITY OF TF2/EXF2 (TIMER2 OVERFLOW INTERRUPT)</p> <p>PS PRIORITY OF RI/TI (SERIAL PORT INTERRUPT)</p> <p>PT1 PRIORITY OF TF1 (TIMER1 OVERFLOW INTERRUPT)</p> <p>PX1 PRIORITY OF IE1 (EXTERNAL INT1)</p> <p>PT0 PRIORITY OF TFO (TIMER0 OVERFLOW INTERRUPT)</p> <p>PX0 PRIORITY OF IE0 (EXTERNAL INT0)</p>	<p>T2CON TIMER2 CONTROL REGISTER</p> <p>TF2 OVERFLOW FLAG</p> <p>EXF2 EXTERNAL FLAG</p> <p>RCLK RECEIVE CLOCK ENABLE (0 = TIMER1 USED FOR RxD CLK)</p> <p>TCLK TRANSMIT CLOCK ENABLE (0 = TIMER1 USED FOR TxD CLK)</p> <p>EXEN2 EXTERNAL ENABLE (0 = IGNORE T2EX, 1 = CAP/RL)</p> <p>TR2 RUN CONTROL (0 = STOP, 1 = RUN)</p> <p>CNT2 TIMER/COUNTER SELECT (0 = TIMER, 1 = COUNTER)</p> <p>CAP2 CAPTURE/RELOAD SELECT (0 = RELOAD, 1 = CAPTURE)</p>	<p>I2CCON I²C CONTROL REGISTER</p> <p>MDO MASTER MODE SDATA OUTPUT BIT</p> <p>MDE MASTER MODE SDATA OUTPUT ENABLE</p> <p>MCO MASTER MODE SCLK BIT</p> <p>MDI MASTER MODE SDATA INPUT BIT</p> <p>I2CM MASTER MODE SELECT</p> <p>I2CRS SERIAL PORT RESET</p> <p>I2CTX TRANSMISSION DIRECTION STATUS</p> <p>I2CI SERIAL INTERFACE INTERRUPT</p>
<p>TMOD TIMER MODE REGISTER</p> <p>TMOD.3/7 GATE CONTROL BIT (0 = IGNORE INTx)</p> <p>TMOD.2/6 COUNTER/TIMER SELECT BIT (0 = TIMER)</p> <p>TMOD.1/5 TIMER MODE SELECTON BITS</p> <p>TMOD.0/4 [13 BIT T, 16 BIT T/C, 8 BIT T/C RELOAD, 2 × 8 BIT T]</p> <p>(UPPER NIBBLE = TIMER1, LOWER NIBBLE = TIMER2)</p>	<p>TH2, TL2 TIMER2 REGISTER</p> <p>RCAP2H, RCAP2L TIMER2 CAPTURE/RELOAD</p>	<p>I2CADD I²C ADDRESS REGISTER</p> <p>I2CDAT I²C DATA REGISTER</p>

Figure 19. Interrupt, Timer, SPI and I²C Control SFRs

TIMING SPECIFICATIONS^{1, 2, 3} $AV_{DD} = DV_{DD} = +3.0\text{ V or }5.0\text{ V} \pm 10\%$. All specifications $T_A = T_{MIN}$ to T_{MAX} unless otherwise noted.

Parameter	12 MHz			Variable Clock			Units	Figure
	Min	Typ	Max	Min	Typ	Max		
CLOCK INPUT (External Clock Driven XTAL1)								
t_{CK}		83.33		62.5		1000	ns	20
t_{CKL}	20			20			ns	20
t_{CKH}	20			20			ns	20
t_{CKR}			20			20	ns	20
t_{CKF}			20			20	ns	20
t_{CYC} ⁴		1			$12t_{CK}$		μs	

NOTES

¹AC inputs during testing are driven at $DV_{DD} - 0.5\text{ V}$ for a Logic 1 and 0.45 V for a Logic 0. Timing measurements are made at V_{IH} min for a Logic 1 and V_{IL} max for a Logic 0.

²For timing purposes, a port pin is no longer floating when a 100 mV change from load voltage occurs. A port pin begins to float when a 100 mV change from the loaded V_{OH}/V_{OL} level occurs.

³ C_{LOAD} for Port0, ALE, \overline{PSEN} outputs = 100 pF; C_{LOAD} for all other outputs = 80 pF unless otherwise noted.

⁴ADuC812 Machine Cycle Time is nominally defined as $MCLKIN/12$.

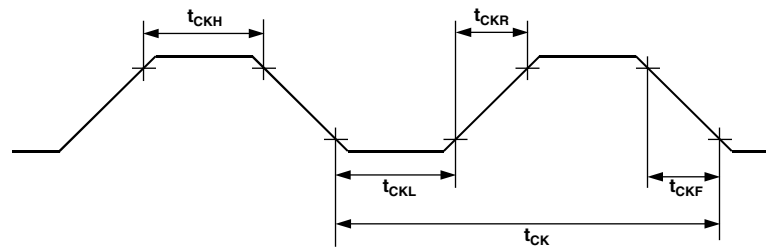

Figure 20. XTAL 1 Input

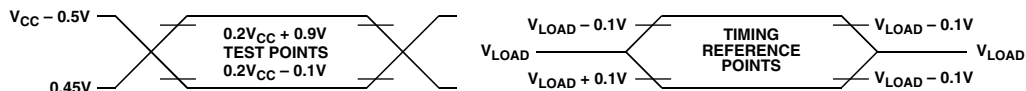

Figure 21. Timing Waveform Characteristics

Parameter	12 MHz		Variable Clock		Units	Figure	
	Min	Max	Min	Max			
EXTERNAL PROGRAM MEMORY							
t_{LHLL}		127		$2t_{CK} - 40$	ns	22	
t_{AVLL}		43		$t_{CK} - 40$	ns	22	
t_{LLAX}		53		$t_{CK} - 30$	ns	22	
t_{LLIV}			234		$4t_{CK} - 100$	ns	22
t_{LLPL}		53		$t_{CK} - 30$	ns	22	
t_{PLPH}		205		$3t_{CK} - 45$	ns	22	
t_{PLIV}			145		$3t_{CK} - 105$	ns	22
t_{PXIX}		0		0	ns	22	
t_{PXIZ}			59		$t_{CK} - 25$	ns	22
t_{AVIV}			312		$5t_{CK} - 105$	ns	22
t_{PLAZ}			25		25	ns	22
t_{PHAX}		0		0	ns	22	

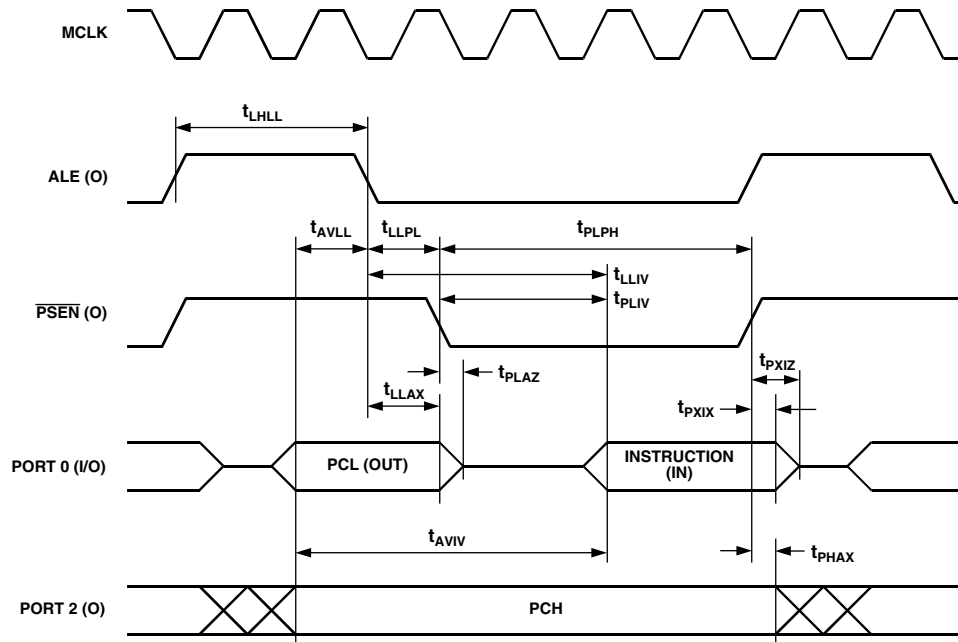

Figure 22. External Program Memory Read Cycle

Parameter	12 MHz		Variable Clock		Units	Figure
	Min	Max	Min	Max		
EXTERNAL DATA MEMORY READ CYCLE						
t_{RLRH}	\overline{RD} Pulsewidth		$6t_{CK} - 100$		ns	23
t_{AVLL}	Address Valid After ALE Low		$t_{CK} - 40$		ns	23
t_{LLAX}	Address Hold After ALE Low		$t_{CK} - 35$		ns	23
t_{RLDV}	\overline{RD} Low to Valid Data In		0		ns	23
t_{RHDX}	Data and Address Hold After \overline{RD}		0		$5t_{CK} - 165$	ns
t_{RHDZ}	Data Float After \overline{RD}		0		$2t_{CK} - 70$	ns
t_{LLDV}	ALE Low to Valid Data In		0		$8t_{CK} - 150$	ns
t_{AVDV}	Address to Valid Data In		0		$9t_{CK} - 165$	ns
t_{LLWL}	ALE Low to \overline{RD} or \overline{WR} Low		$3t_{CK} - 50$		$3t_{CK} + 50$	ns
t_{AVWL}	Address Valid to \overline{RD} or \overline{WR} Low		$4t_{CK} - 130$			ns
t_{RLAZ}	\overline{RD} Low to Address Float		0		0	ns
t_{WHLH}	\overline{RD} or \overline{WR} High to ALE High		$t_{CK} - 40$		$6t_{CK} - 100$	ns

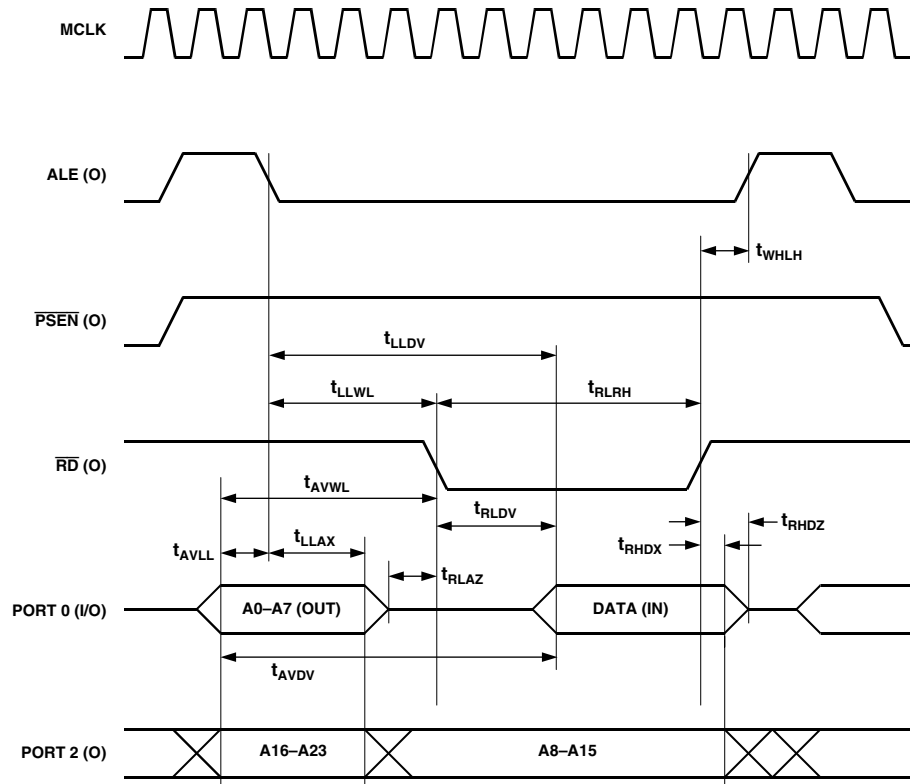

Figure 23. External Data Memory Read Cycle

ADuC812

Parameter	12 MHz		Variable Clock		Units	Figure	
	Min	Max	Min	Max			
EXTERNAL DATA MEMORY WRITE CYCLE							
t_{WLWH}	\overline{WR} Pulsewidth		400	$6t_{CK} - 100$	ns	24	
t_{AVLL}	Address Valid After ALE Low		43	$t_{CK} - 40$	ns	24	
t_{LLAX}	Address Hold After ALE Low		48	$t_{CK} - 35$	ns	24	
t_{LLWL}	ALE Low to \overline{RD} or \overline{WR} Low		200	300	$3t_{CK} - 50$ $3t_{CK} + 50$	ns	24
t_{AVWL}	Address Valid to \overline{RD} or \overline{WR} Low		203	$4t_{CK} - 130$	ns	24	
t_{QVWX}	Data Valid to \overline{WR} Transition		33	$t_{CK} - 50$	ns	24	
t_{QVWH}	Data Setup Before \overline{WR}		433	$7t_{CK} - 150$	ns	24	
t_{WHQX}	Data and Address Hold After \overline{WR}		33	$t_{CK} - 50$	ns	24	
t_{WHLH}	\overline{RD} or \overline{WR} High to ALE High		43	123	$t_{CK} - 40$ $6t_{CK} - 100$	ns	24

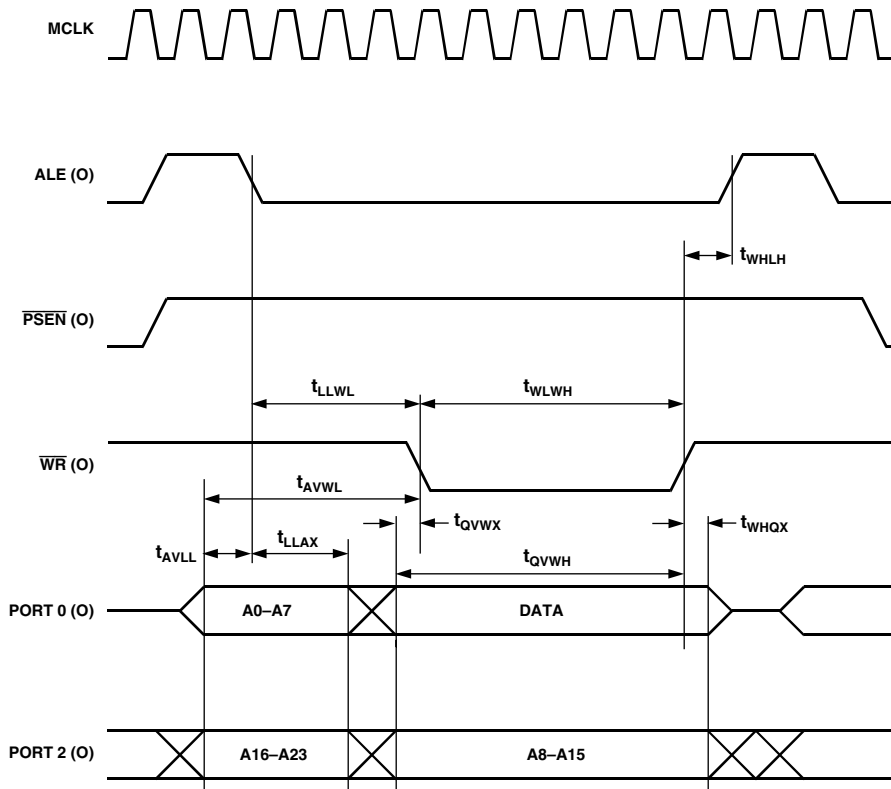

Figure 24. External Data Memory Write Cycle

Parameter	12 MHz			Variable Clock			Units	Figure
	Min	Typ	Max	Min	Typ	Max		
UART TIMING (Shift Register Mode)								
t_{XLXL}		1.0			$12t_{CK}$		μ s	25
t_{QVXH}	700			$10t_{CK} - 133$			ns	25
t_{DVXH}	300			$2t_{CK} + 133$			ns	25
t_{XHDX}	0			0			ns	25
t_{XHGX}	50			$2t_{CK} - 117$			ns	25

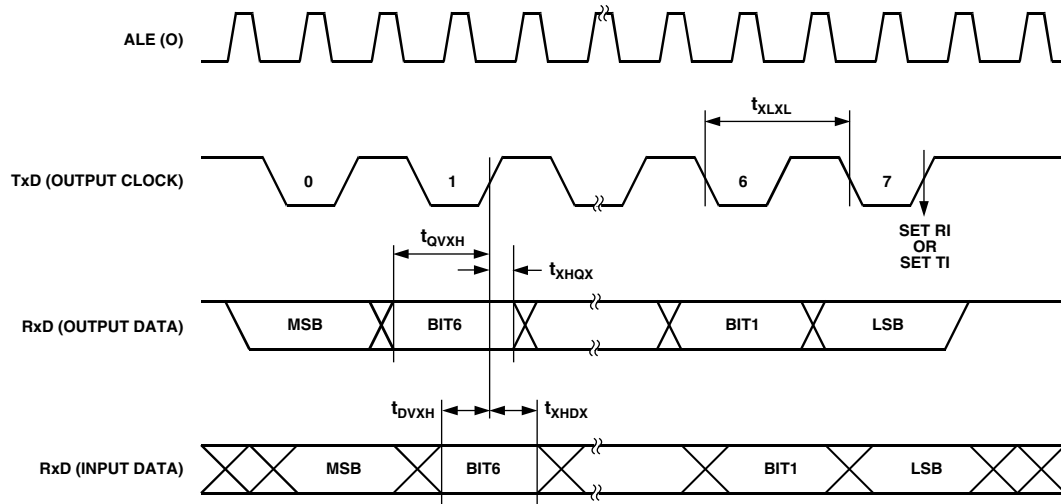

Figure 25. UART Timing in Shift Register Mode

ADuC812

Parameter		Min	Max	Units	Figure
I²C COMPATIBLE INTERFACE TIMING					
t_L	SCLOCK Low Pulsewidth	4.7		μ s	26
t_H	SCLOCK High Pulsewidth	4.0		μ s	26
t_{SHD}	Start Condition Hold Time	0.6		μ s	26
t_{DSU}	Data Setup Time	100		ns	26
t_{DHD}	Data Hold Time	0	0.9	μ s	26
t_{RSU}	Setup Time for Repeated Start	0.6		μ s	26
t_{PSU}	Stop Condition Setup Time	0.6		μ s	26
t_{BUF}	Bus Free Time Between a STOP Condition and a START Condition	1.3		μ s	26
t_R	Rise Time of Both SCLOCK and SDATA		300	ns	26
t_F	Fall Time of Both SCLOCK and SDATA		300	ns	26
t_{SUP}^1	Pulsewidth of Spike Suppressed		50	ns	26

NOTE

¹Input filtering on both the SCLOCK and SDATA inputs suppress noise spikes which are less than 50 ns.

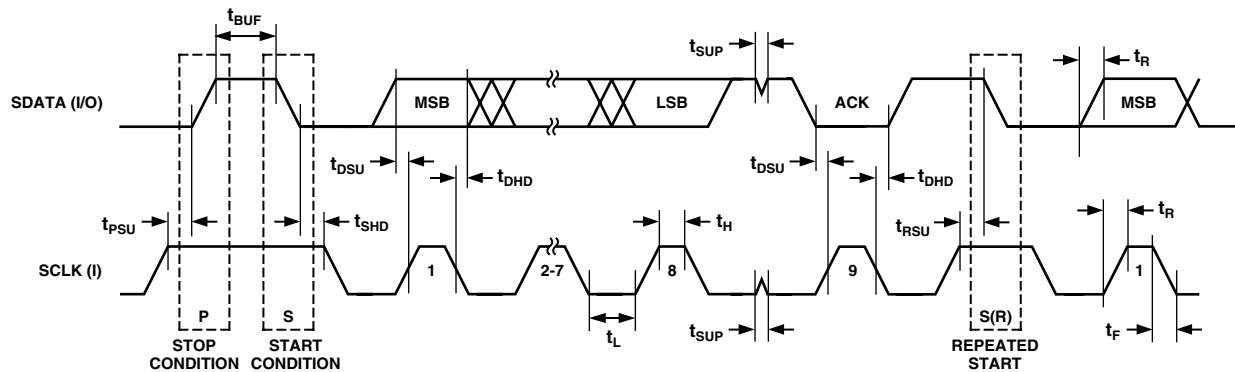

Figure 26. I²C-Compatible Interface Timing

Parameter	Min	Typ	Max	Units	Figure
SPI MASTER MODE TIMING (CPHA = 1)					
t_{SL}		330		ns	27
t_{SH}		330		ns	27
t_{DAV}			50	ns	27
t_{DSU}	100			ns	27
t_{DHD}	100			ns	27
t_{DF}		10	25	ns	27
t_{DR}		10	25	ns	27
t_{SR}		10	25	ns	27
t_{SF}		10	25	ns	27

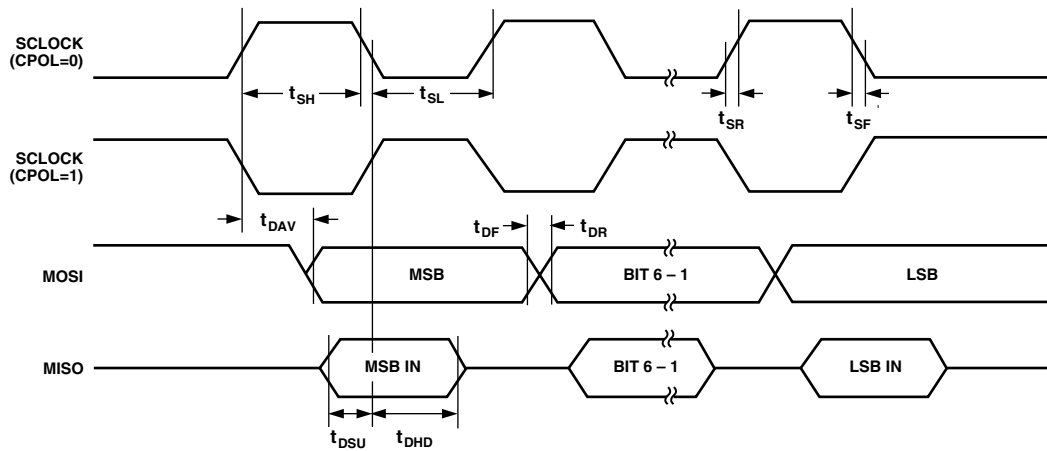

Figure 27. SPI Master Mode Timing (CPHA = 1)

ADuC812

Parameter	Min	Typ	Max	Units	Figure
SPI MASTER MODE TIMING (CPHA = 0)					
t_{SL}		330		ns	28
t_{SH}		330		ns	28
t_{DAV}			50	ns	28
t_{DOSU}			150	ns	28
t_{DSU}	100			ns	28
t_{DHD}	100			ns	28
t_{DF}		10	25	ns	28
t_{DR}		10	25	ns	28
t_{SR}		10	25	ns	28
t_{SF}		10	25	ns	28

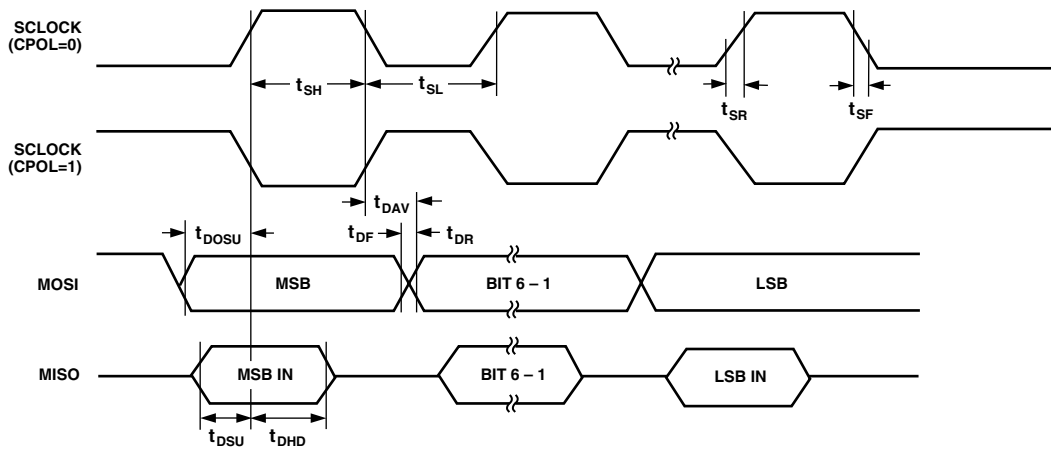

Figure 28. SPI Master Mode Timing (CPHA = 0)

Parameter	Min	Typ	Max	Units	Figure
SPI SLAVE MODE TIMING (CPHA = 1)					
t_{SS}	0			ns	29
t_{SL}		330		ns	29
t_{SH}		330		ns	29
t_{DAV}			50	ns	29
t_{DSU}	100			ns	29
t_{DHD}	100			ns	29
t_{DF}		10	25	ns	29
t_{DR}		10	25	ns	29
t_{SR}		10	25	ns	29
t_{SF}		10	25	ns	29
t_{SFS}	0			ns	29

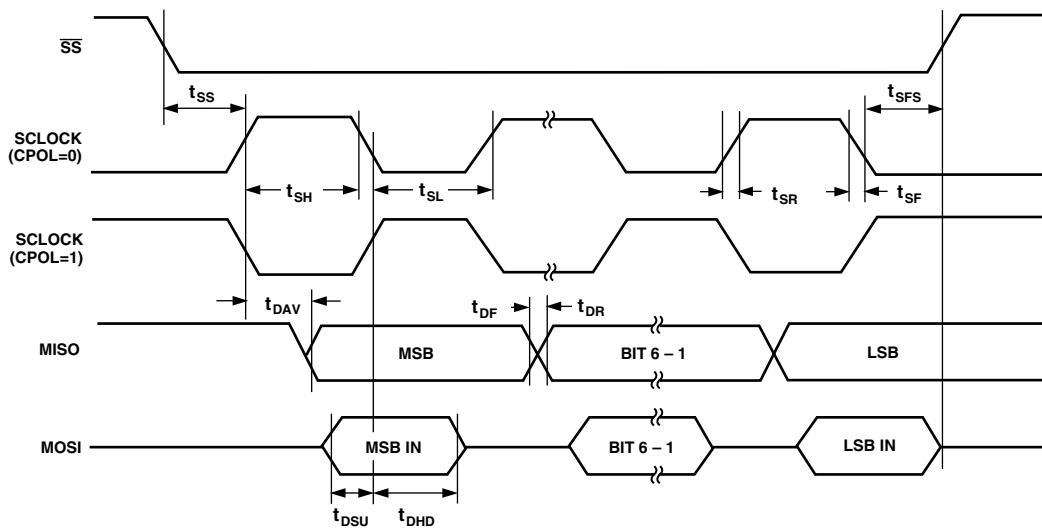

Figure 29. SPI Slave Mode Timing (CPHA = 1)

ADuC812

Parameter	Min	Typ	Max	Units	Figure
SPI SLAVE MODE TIMING (CPHA = 0)					
t_{SS}	0			ns	30
t_{SL}		330		ns	30
t_{SH}		330		ns	30
t_{DAV}			50	ns	30
t_{DSU}	100			ns	30
t_{DHD}	100			ns	30
t_{DF}		10	25	ns	30
t_{DR}		10	25	ns	30
t_{SR}		10	25	ns	30
t_{SF}		10	25	ns	30
t_{DOSS}			20	ns	30
t_{SFS}				ns	30

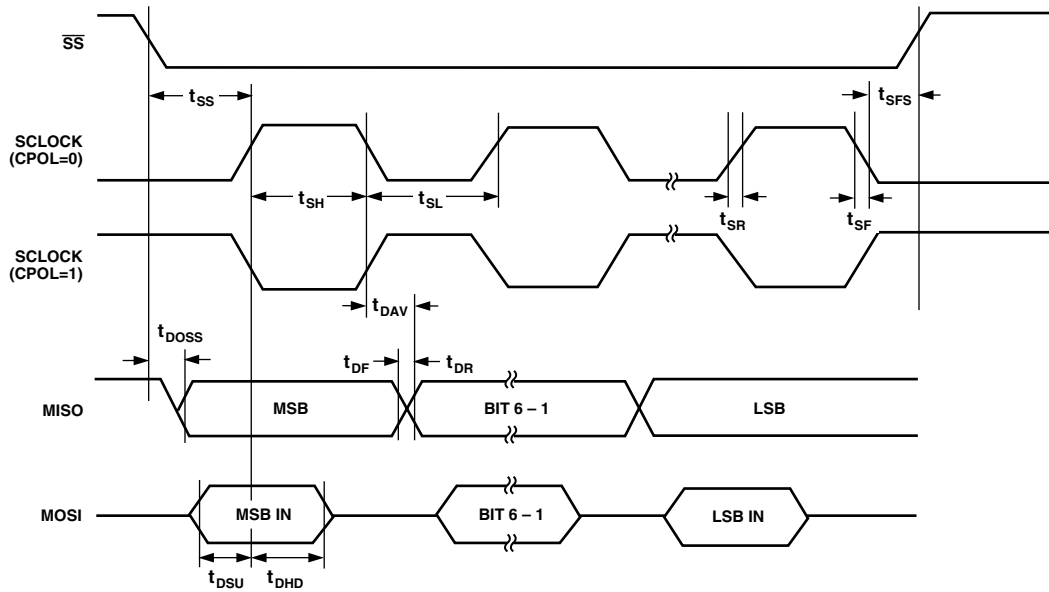
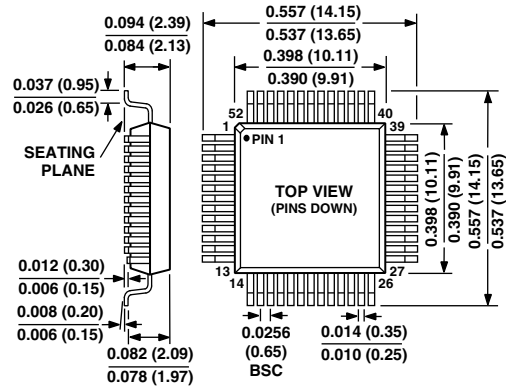

Figure 30. SPI Slave Mode Timing (CPHA = 0)

OUTLINE DIMENSIONS

Dimensions shown in inches and (mm).

**52-Lead Plastic Quad Flatpack
(S-52)**



C3504-8-5/99

PRINTED IN U.S.A.