

PBL 386 40/2 Subscriber Line Interface Circuit

Description

The PBL 386 40/2 Subscriber Line Interface Circuit (SLIC) is a 90 V bipolar integrated circuit for use in Digital Loop Carrier, FITL and other telecommunications equipment. The PBL 386 40/2 has been optimized for low total line interface cost and a high degree of flexibility in different applications.

The PBL 386 40/2 emulates resistive loop feed, programmable between $2 \times 50 \Omega$ and $2 \times 900 \Omega$, with short loop current limiting adjustable to max 45 mA. In the current limited region the loop feed is nearly constant current with a slight slope corresponding to $2 \times 30 \text{ k}\Omega$.

A second, lower battery voltage may be connected to the device to reduce short loop power dissipation. The SLIC automatically switches between the two battery supply voltages without need for external components or external control.

The SLIC incorporates loop current, ground key and ring trip detection functions. The PBL 386 40/2 is compatible with both loop and ground start signaling.

Two- to four-wire and four- to two-wire voice frequency (VF) signal conversion is accomplished by the SLIC in conjunction with either a conventional CODEC/filter or with a programmable CODEC/filter, e.g. SLAC, SiCoFi, Combo II. The programmable two-wire impedance, complex or real, is set by a simple external network.

Longitudinal voltages are suppressed by a feedback loop in the SLIC and the longitudinal balance specifications meet the DLC requirements.

The PBL 386 40/2 package options are 24-pin SSOP package, 24-pin SOIC and 28-pin PLCC.

Key Features

- 24-pin SSOP package
- High and low battery with automatic switching
- 65 mW on-hook power dissipation in active state
- On-hook transmission
- Long loop battery feed tracks Vbat for maximum line voltage
- Only +5 V feed in addition to battery
- Selectable transmit gain (1x or 0.5x)
- No power-up sequence
- Programmable signal headroom
- 43V open loop voltage @ -48V battery feed
- Constant loop voltage for line leakage <5 mA (RLeak ~ >10 k Ω @ -48V)
- Full longitudinal current capability during on-hook state
- Analog over temperature protection permits transmission while the protection circuit is active
- Line voltage measurement
- Polarity reversal
- Ground key detector
- Tip open state with ring ground detector
- -40°C to +85°C ambient temperature range

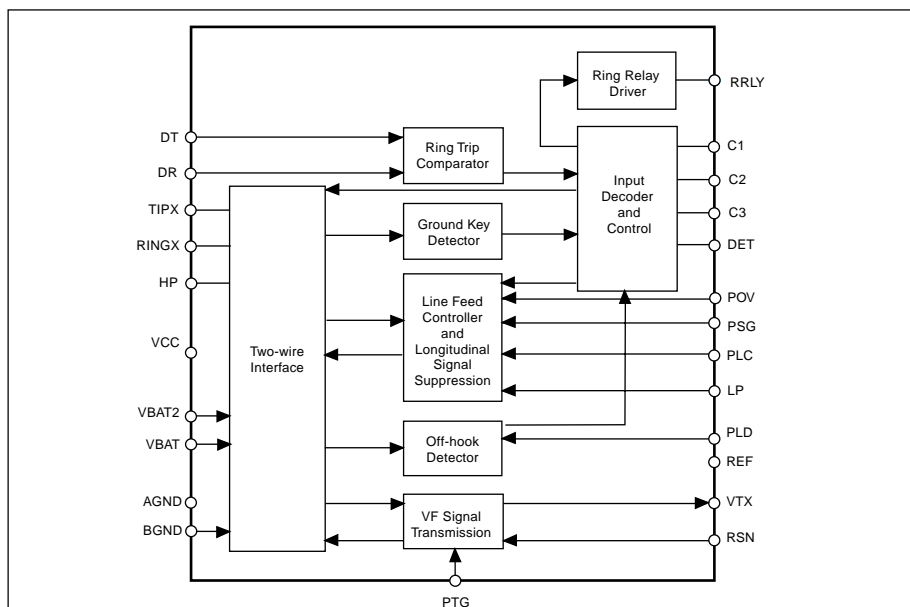
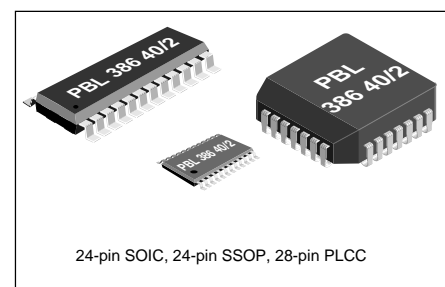

Figure 1. Block diagram.



Maximum Ratings

Parameter	Symbol	Min	Max	Unit
Temperature, Humidity				
Storage temperature range	T_{Stg}	-55	+150	°C
Operating temperature range	T_{Amb}	-40	+110	°C
Operating junction temperature range, Note 1	T_J	-40	+140	°C
Power supply, $-40^{\circ}\text{C} \leq T_{Amb} \leq +85^{\circ}\text{C}$				
V_{CC} with respect to A/BGND	V_{CC}	-0.4	6.5	V
V_{Bat2} with respect to A/BGND	V_{Bat2}	V_{Bat}	0.4	V
V_{Bat} with respect to A/BGND, continuous	V_{Bat}	-75	0.4	V
V_{Bat} with respect to A/BGND, 10 ms	V_{Bat}	-80	0.4	V
Power dissipation				
Continuous power dissipation at $T_{Amb} \leq +85^{\circ}\text{C}$	P_D		1.5	W
Ground				
Voltage between AGND and BGND	V_G	-0.3	+0.3	V
Relay Driver				
Ring relay supply voltage			BGND+14	V
Ring trip comparator				
Input voltage	V_{DT}, V_{DR}	V_{Bat}	AGND	V
Input current	I_{DT}, I_{DR}	-5	5	mA
Digital inputs, outputs (C1, C2, C3, DET)				
Input voltage	V_{ID}	-0.4	V_{CC}	V
Output voltage	V_{OD}	-0.4	V_{CC}	V
TIPX and RINGX terminals, $-40^{\circ}\text{C} < T_{Amb} < +85^{\circ}\text{C}$, $V_{Bat} = -50\text{V}$				
Maximum supplied TIPX or RINGX current	I_{TIPX}, I_{RINGX}	-100	+100	mA
TIPX or RINGX voltage, continuous (referenced to AGND), Note 2	V_{TA}, V_{RA}	-80	2	V
TIPX or RINGX, pulse $< 10\text{ ms}$, $t_{Rep} > 10\text{ s}$, Note 2	V_{TA}, V_{RA}	V_{Bat} -10	5	V
TIPX or RINGX, pulse $< 1\ \mu\text{s}$, $t_{Rep} > 10\text{ s}$, Note 2	V_{TA}, V_{RA}	V_{Bat} -25	10	V
TIPX or RINGX, pulse $< 250\text{ ns}$, $t_{Rep} > 10\text{ s}$, Notes 2 & 3	V_{TA}, V_{RA}	V_{Bat} -35	15	V

Recommended Operating Condition

Parameter	Symbol	Min	Max	Unit
Ambient temperature	T_{Amb}	-40	+85	°C
V_{CC} with respect to AGND	V_{CC}	4.75	5.25	V
V_{Bat} with respect to AGND	V_{Bat}	-58	-8	V
AGND with respect to BGND	V_G	-100	100	mV

Notes

1. The circuit includes thermal protection. Operation at or above 140°C junction temperature may degrade device reliability.
2. With the diodes D_{VB} and D_{VB2} included, see figure 12.
3. R_{F1} and $R_{F2} \geq 20\ \Omega$ is also required. Pulse is applied to TIP and RING outside R_{F1} and R_{F2} .

Electrical Characteristics

-40 °C ≤ T_{Amb} ≤ +85 °C, PTG = open (see pin description), V_{CC} = +5V ±5 %, V_{Bat} = -58V to -40V, V_{Bat2} = -32V, R_{LC} = 32.4 kΩ, I_L = 27 mA. R_L = 600 Ω, R_{F1} = R_{F2} = 0, R_{Ref} = 49.9 kΩ, C_{HP} = 47nF, C_{LP} = 0.15 μF, R_T = 120 kΩ, R_{SG} = 0 kΩ, R_{RX} = 60 kΩ, R_R = 52.3 kΩ, R_{OV} = ∞ unless otherwise specified. Current definition: current is positive if flowing into a pin.

Parameter	Ref fig	Conditions	Min	Typ	Max	Unit
Two-wire port						
Overhead voltage, V _{TRO} , I _{Ldc} ≥ 18mA	2	Active state 1% THD, R _{OV} = ∞	2.7			V _{Peak}
On-Hook, I _{Ldc} ≤ 5mA		Note 1	1.1			V _{Peak}
Input impedance, Z _{TR}		Note 2		Z _T /200		
Longitudinal impedance, Z _{LOT} , Z _{LOR}		0 < f < 100 Hz		20	35	Ω/wire
Longitudinal current limit, I _{LOT} , I _{LOR}		active state	28			mA _{rms} /wire
Longitudinal to metallic balance, B _{LM}		IEEE standard 455-1985, Z _{TRX} = 736Ω Normal polarity: 0.2 kHz < f < 1.0 kHz, T _{amb} 0-70°C 1.0 kHz < f < 3.4 kHz, T _{amb} 0-70°C 0.2 kHz < f < 1.0 kHz, T _{amb} -40-85°C 1.0 kHz < f < 3.4 kHz, T _{amb} -40-85°C Reverse polarity: 0.2 kHz < f < 1.0 kHz, T _{amb} 0-70°C 1.0 kHz < f < 3.4 kHz, T _{amb} 0-70°C 0.2 kHz < f < 1.0 kHz, T _{amb} -40-85°C 1.0 kHz < f < 3.4 kHz, T _{amb} -40-85°C	63 60 60 55 59 55 55 55	66 66 66 66 66 66 66 66		dB dB dB dB dB dB dB dB
Longitudinal to metallic balance, B _{LME}	3	Normal polarity:				
Longitudinal to four wire balance B _{LFE}	3	0.2 kHz < f < 1.0 kHz, T _{amb} 0-70°C 1.0 kHz < f < 3.4 kHz, T _{amb} 0-70°C 0.2 kHz ≤ f ≤ 1.0 kHz, T _{amb} -40-85°C 1.0 kHz < f < 3.4 kHz, T _{amb} -40-85°C Reverse polarity: 0.2 kHz < f < 1.0 kHz, T _{amb} 0-70°C 1.0 kHz < f < 3.4 kHz, T _{amb} 0-70°C 0.2 kHz < f < 1.0 kHz, T _{amb} -40-85°C 1.0 kHz < f < 3.4 kHz, T _{amb} -40-85°C	63 60 60 55 59 55 55 55	66 66 66 66 66 66 66 66		dB dB dB dB dB dB dB dB
B _{LME} = 20 · Log $\frac{E_{Lo}}{V_{TR}}$						
B _{LFE} = 20 · Log $\frac{E_{Lo}}{V_{TX}}$						
Metallic to longitudinal balance, B _{MLE}	4	0.2 kHz < f < 3.4 kHz	40	50		dB
B _{MLE} = 20 · Log $\frac{V_{TR}}{V_{Lo}}$; E _{RX} = 0						

Figure 2. Overhead voltage, V_{TRO}, two-wire port

$$\frac{1}{\omega C} \ll R_L, R_L = 600 \Omega$$

$$R_T = 120 \text{ k}\Omega, R_{RX} = 60 \text{ k}\Omega$$

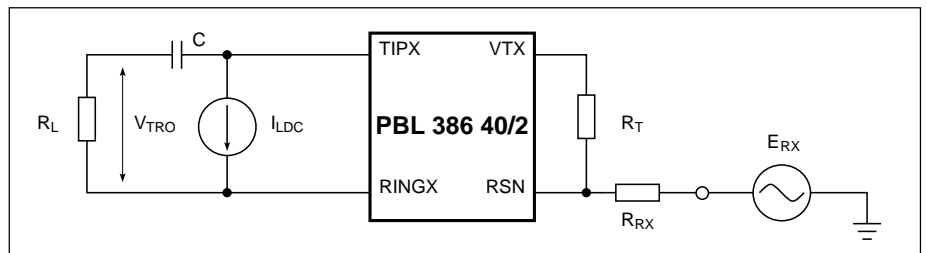
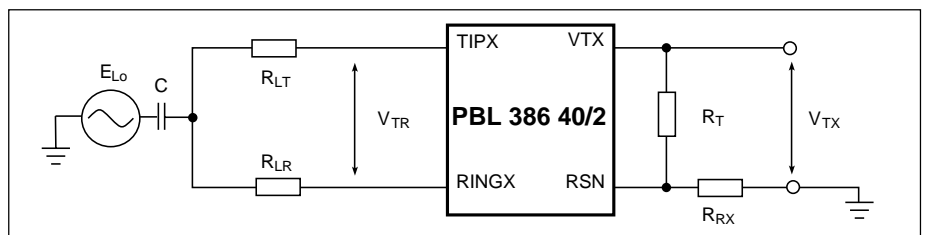

Figure 3. Longitudinal to metallic (B_{LME}) and Longitudinal to four-wire (B_{LFE}) balance

$$\frac{1}{\omega C} \ll 150 \Omega, R_{LR} = R_{LT} = R_L / 2 = 300 \Omega$$

$$R_T = 120 \text{ k}\Omega, R_{RX} = 60 \text{ k}\Omega$$



Parameter	Ref fig	Conditions	Min	Typ	Max	Unit
Four-wire to longitudinal balance, B_{FLE}	4	0.2 kHz < f < 3.4 kHz $B_{FLE} = 20 \cdot \text{Log} \left \frac{E_{RX}}{V_{Lo}} \right $	40	50		dB
Two-wire return loss, r		$r = 20 \cdot \text{Log} \frac{ Z_{TR} + Z_L }{ Z_{TR} - Z_L }$ 0.2 kHz < f < 1.0 kHz 1.0 kHz < f < 3.4 kHz, Note 3	30 20	35 22		dB dB
TIPX idle voltage, V_{Ti}		active, $I_L < 5 \text{ mA}$		- 1.3		V
RINGX idle voltage, V_{Ri}		active, $I_L < 5 \text{ mA}$ tip open, $I_L < 5 \text{ mA}$		$V_{Bat} + 3.0$ $V_{Bat} + 3.0$		V V
V_{TR}		active, $I_L < 5 \text{ mA}$		$V_{Bat} + 4.3$		V
Four-wire transmit port (VTX)						
Overhead voltage, V_{TXO} , $I_L \geq 18 \text{ mA}$	5	Load impedance > 20 k Ω , 1% THD, Note 4	2.7			V_{Peak}
On-hook, $I_L \leq 5 \text{ mA}$			1.1			V_{Peak}
Output offset voltage, ΔV_{TX}			-100	0	100	mV
Output impedance, Z_{TX}		0.2 kHz < f < 3.4 kHz		15	50	Ω
Four-wire receive port (RSN)						
Receive summing node (RSN) DC voltage		$I_{RSN} = -55 \mu\text{A}$	1.15	1.25	1.35	V
Receive summing node (RSN) impedance		0.2 kHz < f < 3.4 kHz		8	20	Ω
Receive summing node (RSN) current (I_{RSN}) to metallic loop current (I_L) gain, α_{RSN}		0.3 kHz < f < 3.4 kHz		200		ratio
Frequency response						
Two-wire to four-wire, g_{2-4}	6	relative to 0 dBm, 1.0 kHz. $E_{RX} = 0 \text{ V}$ 0.3 kHz < f < 3.4 kHz f = 8.0 kHz, 12 kHz, 16 kHz	-0.20 -1.0		0.10 0.1	dB dB

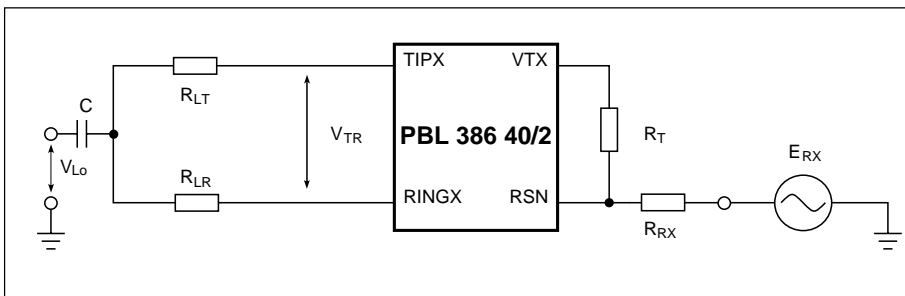

Figure 4. Metallic to longitudinal and four-wire to longitudinal balance

$$\frac{1}{\omega C} \ll 150 \Omega, R_{LT} = R_{LR} = R_L / 2 = 300 \Omega$$

$$R_T = 120 \text{ k}\Omega, R_{RX} = 60 \text{ k}\Omega$$

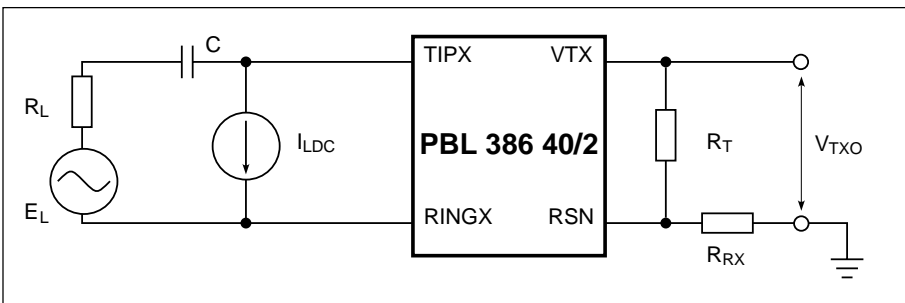

Figure 5. Overhead voltage, V_{TXO} , four-wire transmit port

$$\frac{1}{\omega C} \ll R_L, R_L = 600 \Omega$$

$$R_T = 120 \text{ k}\Omega, R_{RX} = 60 \text{ k}\Omega$$

Parameter	Ref fig	Conditions	Min	Typ	Max	Unit
Four-wire to two-wire, g_{4-2}	6	relative to 0 dBm, 1.0 kHz. $E_L=0$ V				
		0.3 kHz < f < 3.4 kHz	-0.2		0.1	dB
		f = 8 kHz, 12 kHz, 16 kHz	-1.0		0	dB
Four-wire to four-wire, g_{4-4}	6	relative to 0 dBm, 1.0 kHz, $E_L=0$ V 0.3 kHz < f < 3.4 kHz	-0.2		0.1	dB
Insertion loss						
Two-wire to four-wire, G_{2-4}	6	0 dBm, 1.0 kHz, Note 5				
		$G_{2-4} = 20 \cdot \text{Log} \left \frac{V_{TX}}{V_{TR}} \right $; $E_{RX} = 0$	-0.2		0.2	dB
		PTG = AGND	-6.22	-6.02	-5.82	dB
Four-wire to two-wire, G_{4-2}	6	0 dBm, 1.0 kHz, Note 6				
		$G_{4-2} = 20 \cdot \text{Log} \left \frac{V_{TR}}{E_{RX}} \right $; $E_L = 0$	-0.2		0.2	dB
Gain tracking						
Two-wire to four-wire	6	Ref. -10 dBm, 1.0 kHz, Note 7				
		-40 dBm to + 3 dBm	-0.1		0.1	dB
		-55 dBm to -40 dBm	-0.2		0.2	dB
Four-wire to two-wire	6	Ref. -10 dBm, 1.0 kHz,				
		-40 dBm to + 3 dBm	-0.1		0.1	dB
		-55 dBm to -40 dBm	-0.2		0.2	dB
Noise						
Idle channel noise at two-wire (TIPX-RINGX) or four-wire (VTX) output		C-message weighting Psophometrical weighting Note 8			12 -78	dBmC dBmp
Harmonic distortion						
Two-wire to four-wire	6	0 dBm		-67	-50	dB
Four-wire to two-wire		0.3 kHz < f < 3.4 kHz		-67	-50	dB
Battery Feed characteristics						
Loop current, I_L , in the current limited region, reference A, B & C	13	$18\text{mA} \leq I_L \leq 45 \text{ mA}$	$0.92 I_L$	I_L	$1.08 I_L$	mA
Tip open state TIPX current, I_{Leak}	7	S = closed; R = 7 k Ω , note 10			-100	μA
Tip open state RINGX current, I_{LRT0}	7	$R_{LRT0} = 0\Omega$, $V_{Bat} = -48\text{V}$		I_L		mA
		$R_{LRT0} = 2.5 \text{ k}\Omega$, $V_{Bat} = -48\text{V}$		17		mA
Tip open state RINGX voltage, V_{RT0}	7	$I_{LRT0} < 23 \text{ mA}$		$V_{Bat} + 6$		V
Tip voltage (ground start)	7	Active state, Tip lead open (S open), Ring lead to ground through 150 Ω	-4	-2.2		V

Figure 6.
Frequency response, insertion loss, gain tracking.

$$\frac{1}{\omega C} \ll R_L, R_L = 600 \Omega$$

$$R_T = 120 \text{ k}\Omega, R_{RX} = 60 \text{ k}\Omega$$

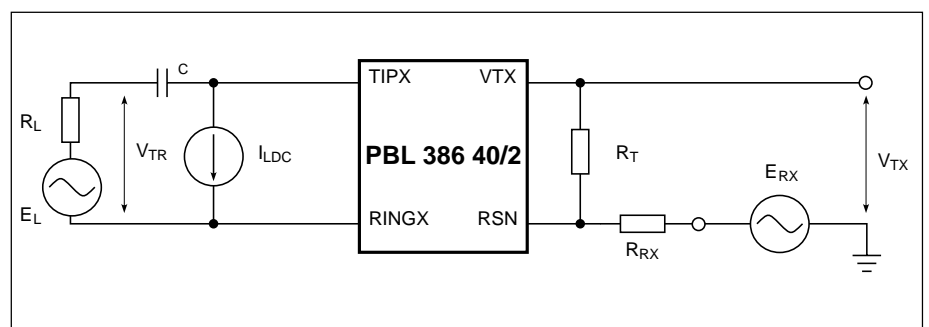

Parameter	Ref fig	Conditions	Min	Typ	Max	Unit
Tip voltage (ground start)	7	Active state, Tip lead to -48 V through 7 kΩ (S closed), Ring lead to ground through 150 Ω	-6	-2.4		V
Open circuit state loop current, I_{LOC}		$R_L = 0\Omega$	-100	0	100	μA
Loop current detector						
Programmable threshold, I_{LTh} , active, active reverse		$I_{LTh} = \frac{500}{R_{LD}}$ R_{LD} in kΩ, $I_{LTh} \geq 7$ mA	$0.85 \cdot I_{LTh}$	I_{LTh}	$1.15 \cdot I_{LTh}$	mA
Tip open state		$I_{LTh} = \frac{500}{R_{LD}}$	$0.85 \cdot I_{LTh}$	I_{LTh}	$1.15 \cdot I_{LTh}$	mA
Ground key detector						
Ground key detector threshold (I_{LTIPX} and I_{LRINGX} current difference to trigger ground key det.)			10	16	22	mA
Line voltage measurement						
Pulse width, t_{LVM}		Note 9		5.5		μs/V
Ring trip comparator						
Offset voltage, ΔV_{DTDR}		Source resistance, $R_S = 0\Omega$	-20	0	20	mV
Input bias current, I_B		$I_B = (I_{DT} + I_{DR})/2$	-200	-20	200	nA
Input common mode range, V_{DT} , V_{DR}			$V_{Bat}+1$		-1	V
Ring relay driver						
Saturation voltage, V_{OL}		$I_{OL} = 50$ mA		0.2	0.5	V
Off state leakage current, I_{Lk}		$V_{OH} = 12$ V			10	μA
Digital inputs (C1, C2, C3)						
Input low voltage, V_{IL}			0		0.5	V
Input high voltage, V_{IH}			2.5		V_{CC}	V
Input low current, I_{IL}		$V_{IL} = 0.5$			-50	μA
Input high current, I_{IH}		$V_{IH} = 2.5$ V			50	μA
Detector output (DET)						
Output Low Voltage		$I_{OL} = 0.5$ mA			0.7	V
Internal pull-up resistor				15		kΩ
Power dissipation ($V_{Bat} = -48$V, $V_{Bat2} = -32$ V)						
P_1		Open circuit state, C1, C2, C3 = 0, 0, 0		10	15	mW
P_2		Active state, C1, C2, C3 = 0, 1, 0 Longitudinal current = 0 mA, $I_L = 0$ mA (on-hook)		65	85	mW
P_3		$R_L = 300\Omega$ (off-hook)		730		mW
P_4		$R_L = 800\Omega$ (off-hook)		360		mW
Power supply currents ($V_{Bat} = -48$V)						
V_{CC} current, I_{CC}		Open circuit state		1.2	2	mA
V_{Bat} current, I_{Bat}			-0.1	-0.05		mA
V_{CC} current, I_{CC}		Active state		2.8	4	mA
V_{Bat} current, I_{Bat}		On-hook, Long Current = 0 mA	-1.5	-1.0		mA
Power supply rejection ratios						
V_{CC} to 2- or 4-wire port		Active State	30	42		dB
V_{Bat} to 2- or 4-wire port		$f = 1$ kHz, $V_n = 100$ mV	36	45		dB
V_{Bat2} to 2- or 4-wire port			40	60		dB
Temperature guard						
Junction threshold temperature, T_{JG}				145		°C
Thermal resistance						
24-pin SSOP, $\theta_{JP24ssop}$				55		°C/W
24-pin SOIC, $\theta_{JP24soic}$				43		°C/W
28-pin PLCC, $\theta_{JP28plcc}$				39		°C/W

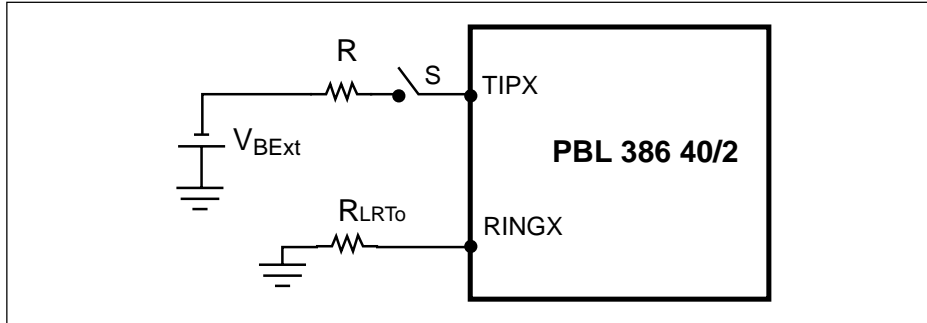

Figure 7. Tipx voltage.

Notes

1. The overhead voltage can be adjusted with the R_{OV} resistor for higher levels e.g. min $3.1 V_{Peak}$ and is specified at the two-wire port with the signal source at the four-wire receive port.
2. The two-wire impedance is programmable by selection of external component values according to:
 $Z_{TRX} = Z_T / |G_{2-4S} \alpha_{RSN}|$ where:
 Z_{TRX} = impedance between the TIPX and RINGX terminals
 Z_T = programming network between the VTX and RSN terminals
 G_{2-4S} = transmit gain, nominally = 1 (or 0.5 see pin PTG)
 α_{RSN} = receive current gain, nominally = 200 (current defined as positive flowing into the receive summing node, RSN, and when flowing from ring to tip).
3. Higher return loss values can be achieved by adding a reactive component to R_T , the two-wire terminating impedance programming resistance, e.g. by dividing R_T into two equal halves and connecting a capacitor from the common point to ground.
4. The overhead voltage can be adjusted with the R_{OV} resistor for higher levels e.g. min $3.1 V_{Peak}$ and is specified at the four-wire transmit port, VTX, with the signal source at the two-wire port. Note that the gain from the two-wire port to the four-wire transmit port is $G_{2-4S} = 1$ (or 0.5 see pin PTG)
5. Pin PTG = Open sets transmit gain to nom. 0.0dB
 Pin PTG = AGND sets transmit gain to nom. -6.02 dB
 Secondary protection resistors R_F impact the insertion loss as explained in the text, section Transmission. The specified insertion loss is for $R_F = 0$.
6. The specified insertion loss tolerance does not include errors caused by external components.
7. The level is specified at the two-wire port.
8. The two-wire idle noise is specified with the port terminated in $600 \Omega (R_L)$ and with the four-wire receive port grounded ($E_{RX} = 0$; see figure 6).
 The four-wire idle noise at VTX is specified with the two-wire port terminated in $600 \Omega (R_L)$. The noise specification is referenced to a 600Ω programmed two-wire impedance level at VTX. The four-wire receive port is grounded ($E_{RX} = 0$).
9. Previous state must be active - loop or ground key detector.
10. If $|V_{BEExt}| \geq |V_{Bat} + 2 V|$, where V_{Bat} is the voltage at V_{BAT} pin, the current I_{Leak} is limited to $\approx 5mA$.

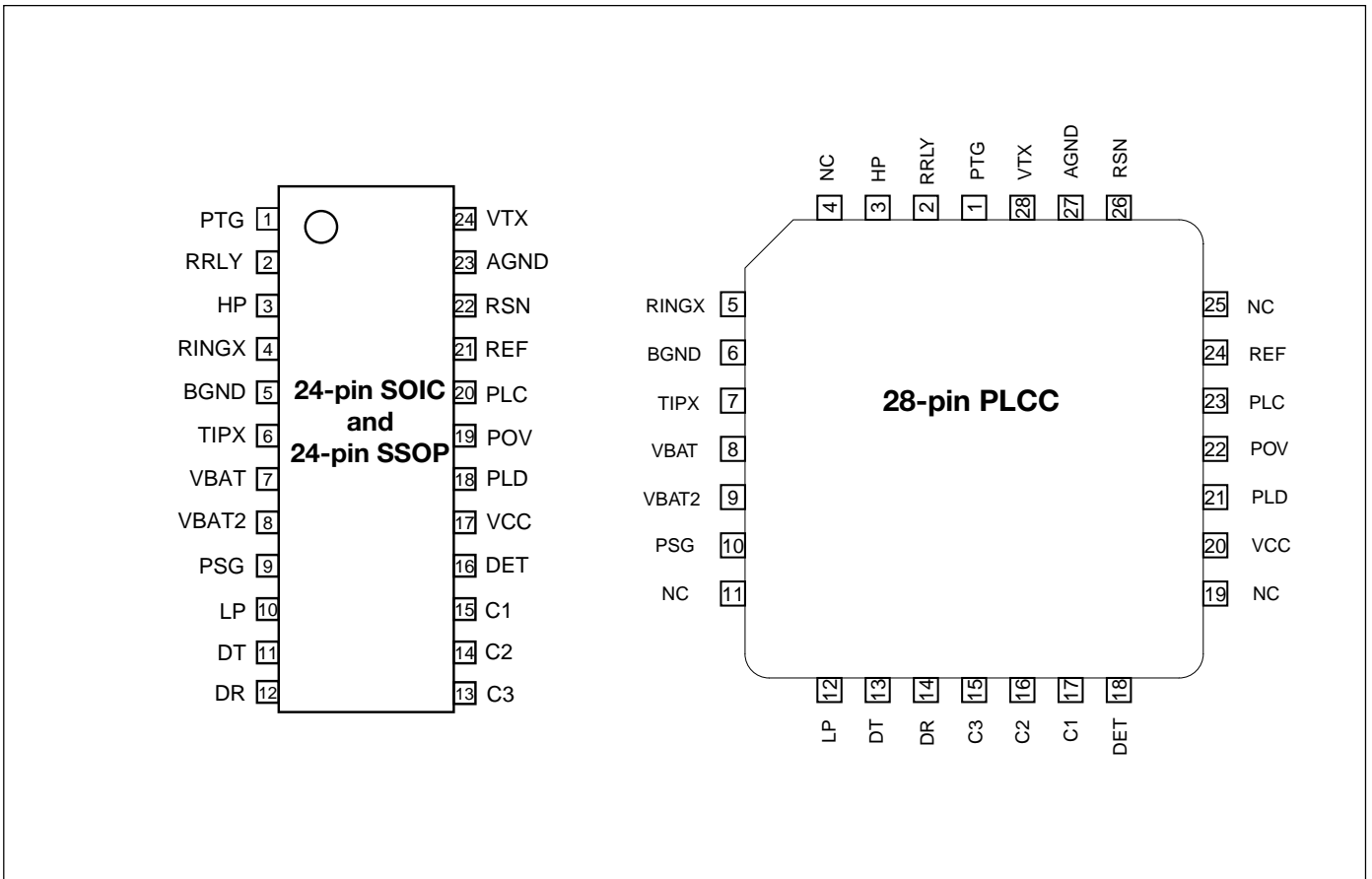

Figure 8. Pin configuration, 24-pin SOIC, 24-pin SSOP and 28 pin PLCC package, top view.

Pin Description

Refer to figure 8.

PLCC	Symbol	Description
1	PTG	Prog. Transmit Gain. Left open transmit gain = 0.0 dB, connected to AGND transmit gain = -6.02 dB.
2	RRLY	Ring Relay driver output. The relay coil may be connected to maximum +14V.
3	HP	Connection for High Pass filter capacitor, C_{HP} . Other end of C_{HP} connects to TIPX.
4	NC	No internal Connection
5	RINGX	The TIPX and RINGX pins connect to the tip and ring leads of the two-wire interface via overvoltage protection components and ring relay (and optional test relay).
6	BGND	Battery Ground , should be tied together with AGND.
7	TIPX	The TIPX and RINGX pins connect to the tip and ring leads of the two-wire interface via overvoltage protection components and ring relay (and optional test relay).
8	VBAT	Battery supply Voltage. Negative with respect to AGND.
9	VBAT2	An optional second (2) Battery Voltage connects to this pin.
10	PSG	Programmable Saturation Guard. The resistive part of the DC Feed characteristic is programmed by a resistor connected from this pin to VBAT.
11	NC	No internal Connection
12	LP	Connection for Low Pass filter capacitor, C_{LP} . Other end of C_{LP} connects to VBAT.
13	DT	Input to the ring trip comparator. With DR more positive than DT the detector output, DET, is at logic level low, indicating off-hook condition. The external ring trip network connects to this input.
14	DR	Input to the ring trip comparator. With DR more positive than DT the detector output, DET, is at logic level low, indicating off-hook condition. The external ring trip network connects to this input.

15	C3	}	C1, C2 and C3 are digital inputs (internal pull-up) controlling the SLIC operating states. Refer to section "Operating states" for details.
16	C2		
17	C1		
18	DET	D etector output. Active low when indicating loop detection and ring trip, active high when indicating ground key detection.	
19	NC	N o internal C onnection	
20	VCC	+5 V power supply.	
21	PLD	P rogrammable L oop D etector threshold. The loop detection threshold is programmed by a resistor connected from this pin to AGND.	
22	POV	P rogrammable O verhead V oltage. If pin is left open: The overhead voltage is internally set to min 2.7 V in off-hook and min 1.1 V in On-hook. If a resistor is connected between this pin and AGND: the overhead voltage can be set to higher values.	
23	PLC	P rog. L ine C urrent, the current limit, reference C in figure 13, is programmed by a resistor connected from this pin to AGND.	
24	REF	A R eference, 49.9 kΩ, resistor should be connected from this pin to AGND.	
25	NC	N o internal C onnection	
26	RSN	R ecieve S umming N ode. 200 times the AC-current flowing into this pin equals the metallic (transversal) AC-current flowing from RINGX to TIPX. Programming networks for two-wire impedance and receive gain connect to the receive summing node. A resistor should be connected from this pin to AGND.	
27	AGND	Analog Ground, should be tied together with BGND.	
28	VTX	Transmit v _f output. The AC voltage difference between TIPX and RINGX, the AC metallic voltage, is reproduced as an unbalanced GND referenced signal at VTX with a gain of one (or one half, see pin PTG). The two-wire impedance programming network connects between VTX and RSN.	

SLIC Operating States

State	C3	C2	C1	SLIC operating state	Active detector
0	0	0	0	Open circuit	-
1	0	0	1	Ringing state	Ring trip detector (active low)
2	0	1	0	Active state	Loop detector (active low)
3	0	1	1	Active state	Line voltage measurement (note 9)
4	1	0	0	Tip open state	Loop detector (active low)
5	1	0	1	Active state	Ground key detector (active high)
6	1	1	0	Active reverse	Loop detector (active low)
7	1	1	1	Active reverse	Ground key detector (active high)

Table 1. SLIC operating states.

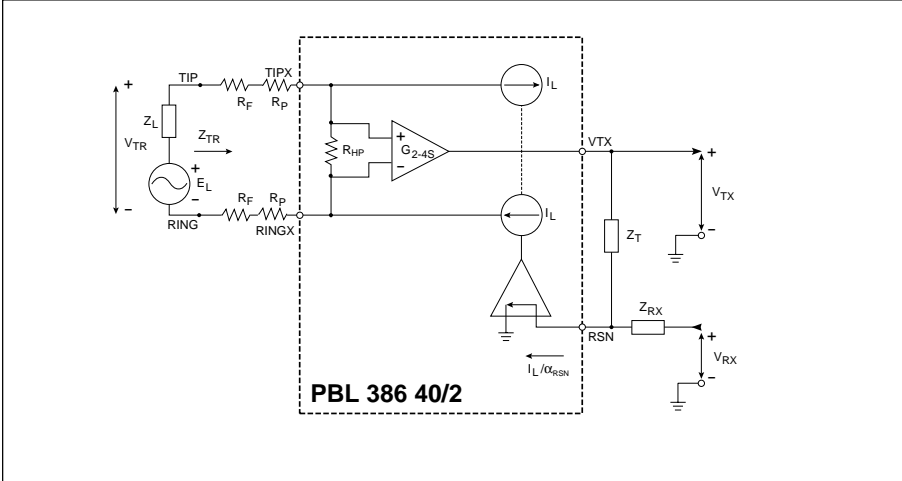

Figure 9. Simplified ac transmission circuit.

Functional Description and Applications Information

Transmission

General

A simplified ac model of the transmission circuits is shown in figure 9. Circuit analysis yields:

$$V_{TR} = \frac{V_{TX}}{G_{2-4S}} + I_L \cdot (2R_F + 2R_P) \quad (1)$$

$$\frac{V_{TX}}{Z_T} + \frac{V_{RX}}{Z_{RX}} = \frac{I_L}{\alpha_{RSN}} \quad (2)$$

$$V_{TR} = E_L - I_L \cdot Z_L \quad (3)$$

where:

V_{TX} is a ground referenced version of the ac metallic voltage between the TIPX and RINGX terminals.

G_{2-4S} is the programmable SLIC two-wire to four-wire gain (transmit direction). See note below.

V_{TR} is the ac metallic voltage between tip and ring.

E_L is the line open circuit ac metallic voltage.

I_L is the ac metallic current.

R_F is a fuse resistor.

R_P is part of the SLIC protection.

Z_L is the line impedance.

Z_T determines the SLIC TIPX to RINGX impedance at voice frequencies.

Z_{RX} controls four- to two-wire gain.

V_{RX} is the analog ground referenced receive signal.

α_{RSN} is the receive summing node current to metallic loop current gain = 200.

Note that the SLICs two-wire to four-wire gain, G_{2-4S} , is user programmable between two fix values. Refer to the datasheets for values on G_{2-4S} .

Two-Wire Impedance

To calculate Z_{TR} , the impedance presented to the two-wire line by the SLIC including the fuse and protection resistors R_F and R_P , let:

$$V_{RX} = 0.$$

From (1) and (2):

$$Z_{TR} = \frac{Z_T}{\alpha_{RSN} \cdot G_{2-4S}} + 2R_F + 2R_P$$

Thus with Z_{TR} , α_{RSN} , G_{2-4S} , R_P and R_F known:

$$Z_T = \alpha_{RSN} \cdot G_{2-4S} \cdot (Z_{TR} - 2R_F - 2R_P)$$

Two-Wire to Four-Wire Gain

From (1) and (2) with $V_{RX} = 0$:

$$G_{2-4} = \frac{V_{TX}}{V_{TR}} = \frac{Z_T / \alpha_{RSN}}{\frac{Z_T}{\alpha_{RSN} \cdot G_{2-4S}} + 2R_F + 2R_P}$$

Four-Wire to Two-Wire Gain

From (1), (2) and (3) with $E_L = 0$:

$$G_{4-2} = \frac{V_{TR}}{V_{RX}} = -\frac{Z_T}{Z_{RX}} \cdot \frac{Z_L}{\alpha_{RSN} + G_{2-4S} \cdot (Z_L + 2R_F + 2R_P)}$$

For applications where

$Z_T / (\alpha_{RSN} \cdot G_{2-4S}) + 2R_F + 2R_P$ is chosen to be equal to Z_L the expression for G_{4-2} simplifies to:

$$G_{4-2} = -\frac{Z_T}{Z_{RX}} \cdot \frac{1}{2G_{2-4S}}$$

Four-Wire to Four-Wire Gain

From (1), (2) and (3) with $E_L = 0$:

$$G_{4-4} = \frac{V_{TX}}{V_{RX}} = -\frac{Z_T}{Z_{RX}} \cdot \frac{G_{2-4S} \cdot (Z_L + 2R_F + 2R_P)}{\alpha_{RSN} + G_{2-4S} \cdot (Z_L + 2R_F + 2R_P)}$$

Hybrid Function

The hybrid function can easily be implemented utilizing the uncommitted amplifier in conventional CODEC/filter combinations. Please, refer to figure 10. Via impedance Z_B a current proportional to V_{RX} is injected into the summing node of the combination CODEC/filter amplifier. As can be seen from the expression for the four-wire to four-wire gain a voltage proportional to V_{RX} is returned to V_{TX} . This voltage is converted by R_{TX} to a current flowing into the same summing node. These currents can be made to cancel by letting:

$$\frac{V_{TX}}{R_{TX}} + \frac{V_{RX}}{Z_B} = 0 (E_L = 0)$$

The four-wire to four-wire gain, G_{4-4} , includes the required phase shift and thus the balance network Z_B can be calculated from:

$$Z_B = -R_{TX} \cdot \frac{V_{RX}}{V_{TX}}$$

$$R_{TX} \cdot \frac{Z_{RX}}{Z_T} \cdot \frac{\alpha_{RSN} + G_{2-4S} \cdot (Z_L + 2R_F + 2R_P)}{G_{2-4S} \cdot (Z_L + 2R_F + 2R_P)}$$

When choosing R_{TX} , make sure the output load of the VTX terminal is $>20\text{ k}\Omega$.

If calculation of the Z_B formula above yields a balance network containing an inductor, an alternate method is recommended. Contact Ericsson Microelectronics for assistance.

The PBL 386 40/2 SLIC may also be used together with programmable CODEC/filters. The programmable CODEC/filter allows for system controller adjustment of hybrid balance to accommodate different line impedances without change of hardware. In addition, the transmit and receive gain may be adjusted. Please, refer to the programmable CODEC/filter data sheets for design information.

Longitudinal Impedance

A feed back loop counteracts longitudinal voltages at the two-wire port by injecting longitudinal currents in opposing phase.

Thus longitudinal disturbances will appear as longitudinal currents and the TIPX and RINGX terminals will experience very small longitudinal voltage excursions, leaving metallic voltages well within the SLIC common mode range.

The SLIC longitudinal impedance per wire, Z_{LoT} and Z_{LoR} , appears as typically $20\ \Omega$ to longitudinal disturbances. It should be noted that longitudinal currents may exceed the dc loop current without disturbing the vf transmission.

Capacitors C_{TC} and C_{RC}

The capacitors designated C_{TC} and C_{RC} in figure 12, connected between TIPX and ground as well as between RINGX and ground, can be used for RFI filtering. The recommended value for C_{TC} and C_{RC} is 2200 pF. Higher capacitance values may be used, but care must be taken to prevent degradation of either longitudinal balance or return loss. C_{TC} and C_{RC} contribute to a metallic impedance of $1/(\pi \cdot f \cdot C_{TC}) = 1/(\pi \cdot f \cdot C_{RC})$, a TIPX to ground impedance of $1/(2 \cdot \pi \cdot f \cdot C_{TC})$ and a RINGX to ground impedance of $1/(2 \cdot \pi \cdot f \cdot C_{RC})$.

AC - DC Separation Capacitor, C_{HP}

The high pass filter capacitor connected between terminals HP and TIPX provides the separation of the ac signal from the dc part. C_{HP} positions the low end

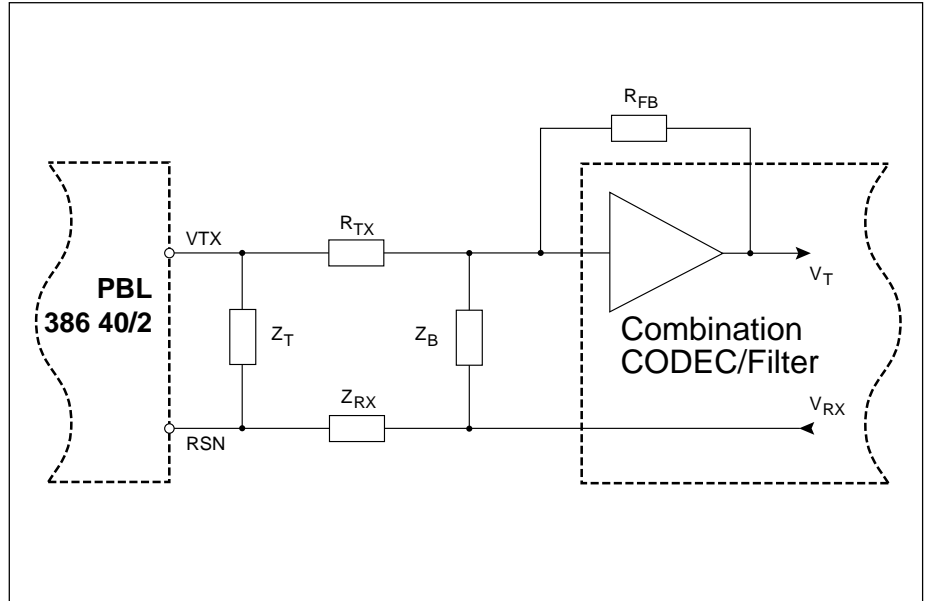

Figure 10. Hybrid function.

frequency response break point of the ac loop in the SLIC. Refer to table 1 for recommended values of C_{HP} . Example: A C_{HP} value of 150 nF will position the low end frequency response 3dB break point of the ac loop at 1.8 Hz (f_{3dB}) according to $f_{3dB} = 1/(2 \cdot \pi \cdot R_{HP} \cdot C_{HP})$ where $R_{HP} = 600\text{ k}\Omega$.

High-Pass Transmit Filter

The capacitor C_{TX} in figure 12 connected between the VTX output and the CODEC/filter forms, together with R_{TX} and/or the input impedance of a programmable CODEC/filter, a high-pass RC filter. It is recommended to position the 3 dB break point of this filter between 30 and 80 Hz to get a faster response for the dc steps that may occur at DTMF signalling.

Capacitor C_{LP}

The capacitor C_{LP} , which connects between the terminals CLP and VBAT, positions together with the resistive loop feed resistor R_{SG} (see section Battery Feed), the high end frequency break point of the low pass filter in the dc loop in the SLIC. C_{LP} together with R_{SG} , C_{HP} and Z_T (see section Two-Wire Impedance) forms the total two wire output

impedance of the SLIC. The choice of these programmable components have an influence on the power supply rejection ratio (PSRR) from VBAT to the two wire side at sub-audio frequencies. At these frequencies capacitor C_{LP} also influences the transversal to longitudinal balance in the SLIC. Table 1 suggests suitable values on C_{LP} for different Feeding characteristics. Typical values of the transversal to longitudinal balance (T-L bal.) at 200Hz is given in table 1 for the chosen values on C_{LP} .

R_{Feed}	R_{SG}	C_{LP}	T-L bal. @200Hz	C_{HP}
[Ω]	[k Ω]	[nF]	[dB]	[nF]
2-50	0	150	-46	47
2-200	60.4	100	-46	150
2-400	147	47	-43	150
2-800	301	22	-36	150

Table 1. R_{SG} , C_{LP} and C_{HP} values for different Feeding characteristics.

Battery Feed

The PBL 386 40/2 SLIC emulate resistive loop Feed, programmable between 2.50Ω and 2.900 Ω, with adjustable current limitation. In the current limited region the loop current has a slight slope corresponding to 2.30 kΩ, see figure 13 reference B.

The open loop voltage measured between the TIPX and RINGX terminals is tracking the battery voltage V_{Bat} . The signalling headroom, or overhead voltage V_{TRO} , is programmable with a resistor R_{OV} connected between terminal POV on the SLIC and ground. Please refer to section "Programmable overhead voltage(POV)".

The battery voltage overhead, V_{OH} , depends on the programmed signal overhead voltage V_{TRO} . V_{OH} defines the TIPX to RINGX voltage at open loop conditions according to $V_{TR}(at I_L = 0 \text{ mA}) = |V_{Bat}| - V_{OH}$.

Refer to table 2 for typical values on V_{OH} and V_{OHvirt} . The overhead voltage is changed when the line current is approaching open loop conditions. To ensure maximum open loop voltage, even with a leaking telephone line, this occurs at a line current of approximately 6 mA. When the overhead voltage has changed, the line voltage is kept nearly constant with a steep slope corresponding to 2.25 Ω(reference G in figure 13).

The virtual battery overhead, V_{OHvirt} , is defined as the difference between the battery voltage and the crossing point of all possible resistive Feeding slopes, see figure 13 reference J. The virtual battery overhead is a theoretical constant needed to be able to calculate the Feeding characteristics.

SLIC	$V_{OH(typ)}$ [V]	$V_{OHvirt(typ)}$ [V]
PBL 386 40/2	3.0 + V_{TRO}	4.9 + V_{TRO}

Table 2. Battery overhead.

The resistive loop Feed (reference D in figure 13) is programmed by connecting a resistor, R_{SG} , between terminals PSG and VBAT according to the equation:

$$R_{Feed} = \frac{R_{SG} + 2 \cdot 10^4}{200} + 2R_F$$

where R_{Feed} is in Ω for R_{SG} , and R_F in Ω.

The current limit (reference C in figure 13) is adjusted by connecting a resistor, R_{LC} , between terminal PLC and ground according to the equation:

$$R_{LC} = \frac{1000}{I_{LProg} + 4}$$

where R_{LC} is in kΩ for I_{LProg} in mA.

A second, lower battery voltage may be connected to the device at terminal VBAT2 to reduce short loop power dissipation. The SLIC automatically switches between the two battery supply voltages without need for external control. The silent battery switching occurs when the line voltage passes the value $|VB2| - 40 \cdot I_L - (V_{OHvirt} - 1.3)$, if $I_L > 6 \text{ mA}$.

For correct functionality it is important to connect the terminal VBAT2 to the second power supply via the diode D_{VB2} in figure 12.

An optional diode D_{BB} connected between terminal VB and the VB2 power supply, see figure 12, will make sure that the SLIC continues to work on the second battery even if the first battery voltage disappears.

If a second battery voltage is not used, VBAT2 is connected to VBAT on the SLIC and C_{VB2} , D_{BB} and D_{VB2} are removed.

Metering applications

For designs with metering applications please contact Ericsson Microelectronics for assistance.

CODEC Receive Interface

The PBL 386 40/2 SLIC have got a completely new receive interface at the four wire side which makes it possible to reduce the number of capacitors in the applications and to fit both single and dual battery Feed CODECs. The RSN terminal, connecting to the CODEC

receive output via the resistor R_{RX} , is dc biased with +1.25V. This makes it possible to compensate for currents floating due to dc voltage differences between RSN and the CODEC output without using any capacitors. This is done by connecting a resistor R_R between the RSN terminal and ground. With current directions defined as in figure 14, current summation gives:

$$-I_{RSN} = I_{RT} + I_{RRX} + I_{RR} =$$

$$\frac{1,25}{R_T} + \frac{1,25 - V_{CODEC}}{R_{RX}} + \frac{1,25}{R_R}$$

where V_{CODEC} is the reference voltage of the CODEC at the receive output. From this equation the resistor R_R can be calculated as

$$R_R = \frac{1,25}{-I_{RSN} - \frac{1,25}{R_T} - \frac{1,25 - V_{CODEC}}{R_{RX}}}$$

For values on I_{RSN} , see table 3. The resistor R_R has no influence on the ac transmission.

SLIC	I_{RSN} [μA]
PBL 386 40/2	-55

Table 3. The SLIC internal bias current with the direction of the current defined as positive when floating into the terminal RSN.

Programmable overhead voltage(POV)

With the POV function the overhead voltage can be increased.

If the POV pin is left open the overhead voltage is internally set to 3,2 V_{Peak} in off-hook and 1,3 V_{Peak} on-hook. If a resistor R_{OV} is connected between the POV pin

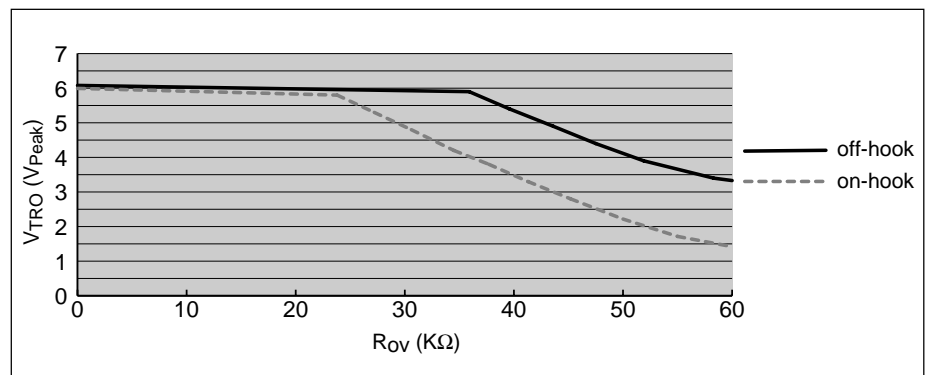

Figure 11. Programmable overhead voltage (POV). $R_L = 600 \Omega$ or ∞ .

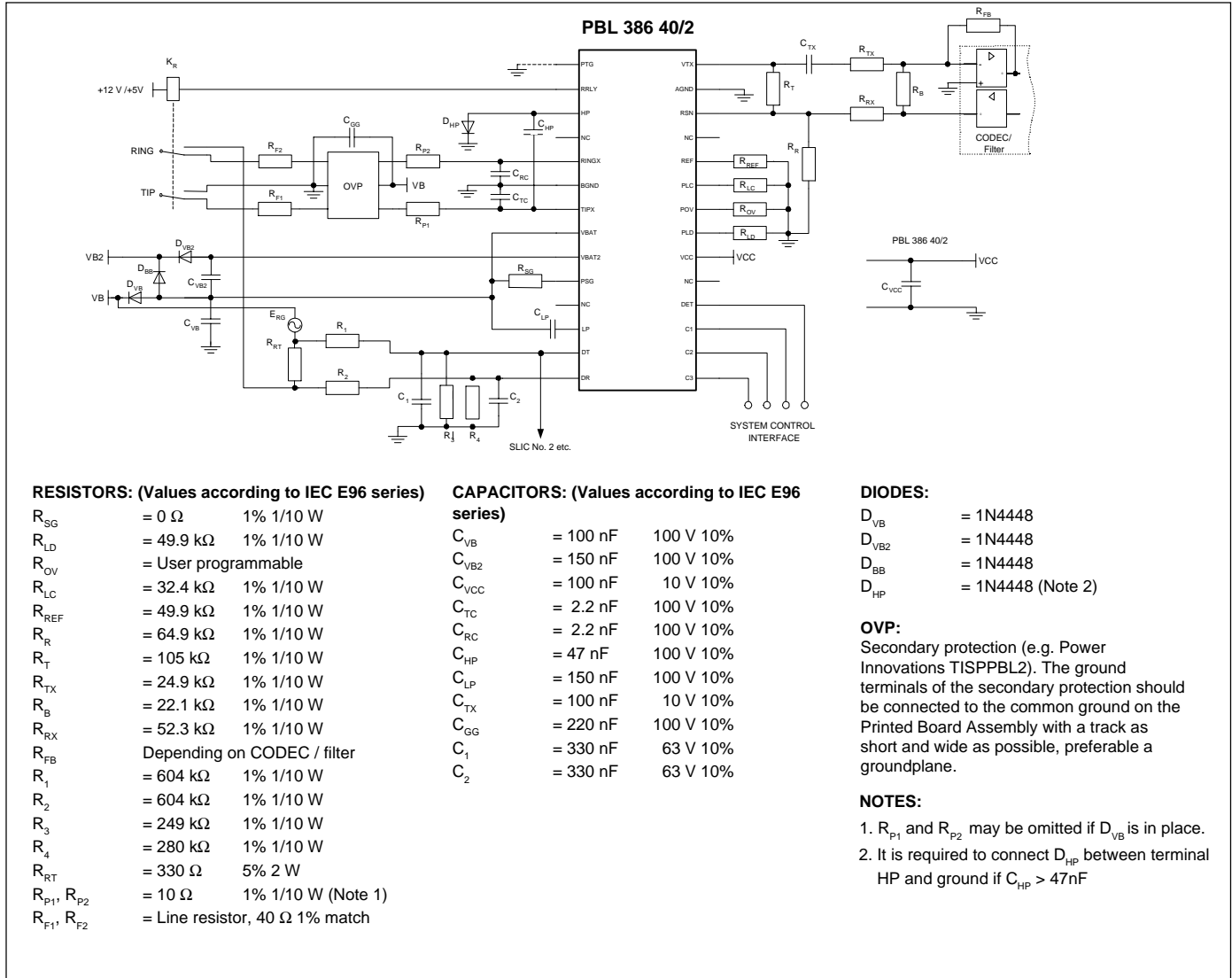

Figure 12. Single-channel subscriber line interface with PBL 386 40/2 and combination CODEC/filter.

and AGND, the overhead voltage can be set to higher values, typical values can be seen in figure 11. The R_{OV} and corresponding V_{TRO} (signal headroom) are typical values for THD <1% and the signal frequency 1000Hz.

Observe that the 4-wire output terminal V_{TX} can not handle more than $3,2 V_{Peak}$. So if the gain 2-wire to 4-wire is 0dB, $3,2 V_{Peak}$ is maximum also for the 2-wire side. Signal levels between $3,2$ and $6,4 V_{Peak}$ on the 2-wire side can be handled with the PTG shorted so that the gain G_{2-4S} become -6,02dB. Please note that the 2-wire impedance, R_R and the 4-wire to 4-wire gain has to be recalculated if the PTG is shorted.

Please note that the maximum signal current at the 2-wire side can not be greater than 9 mA.

How to use POV:

- Decide what overhead voltage (V_{TRO}) is needed. The POV function is only needed if the overhead voltage exceeds $3,2 V_{Peak}$
- In figure 11 the corresponding R_{OV} for the decided V_{TRO} can be found.
- If the overhead voltage exceeds $3,2 V_{Peak}$, the G_{2-4S} gain has to be changed to -6,02dB by connecting the PTG pin to AGND. Please note that the two-wire impedance, R_R and the 4-wire to 4-wire gain has to be recalculated.

Analog Temperature Guard

The widely varying environmental conditions in which SLICs operate may lead to the chip temperature limitations being exceeded. The PBL 386 40/2 SLIC reduce the dc line current when approximately 145°C and increases it again automatically when the temperature drops. Accordingly transmission is not lost under high ambient temperature conditions.

The detector output, DET, is forced to a logic low level when the temperature guard is active.

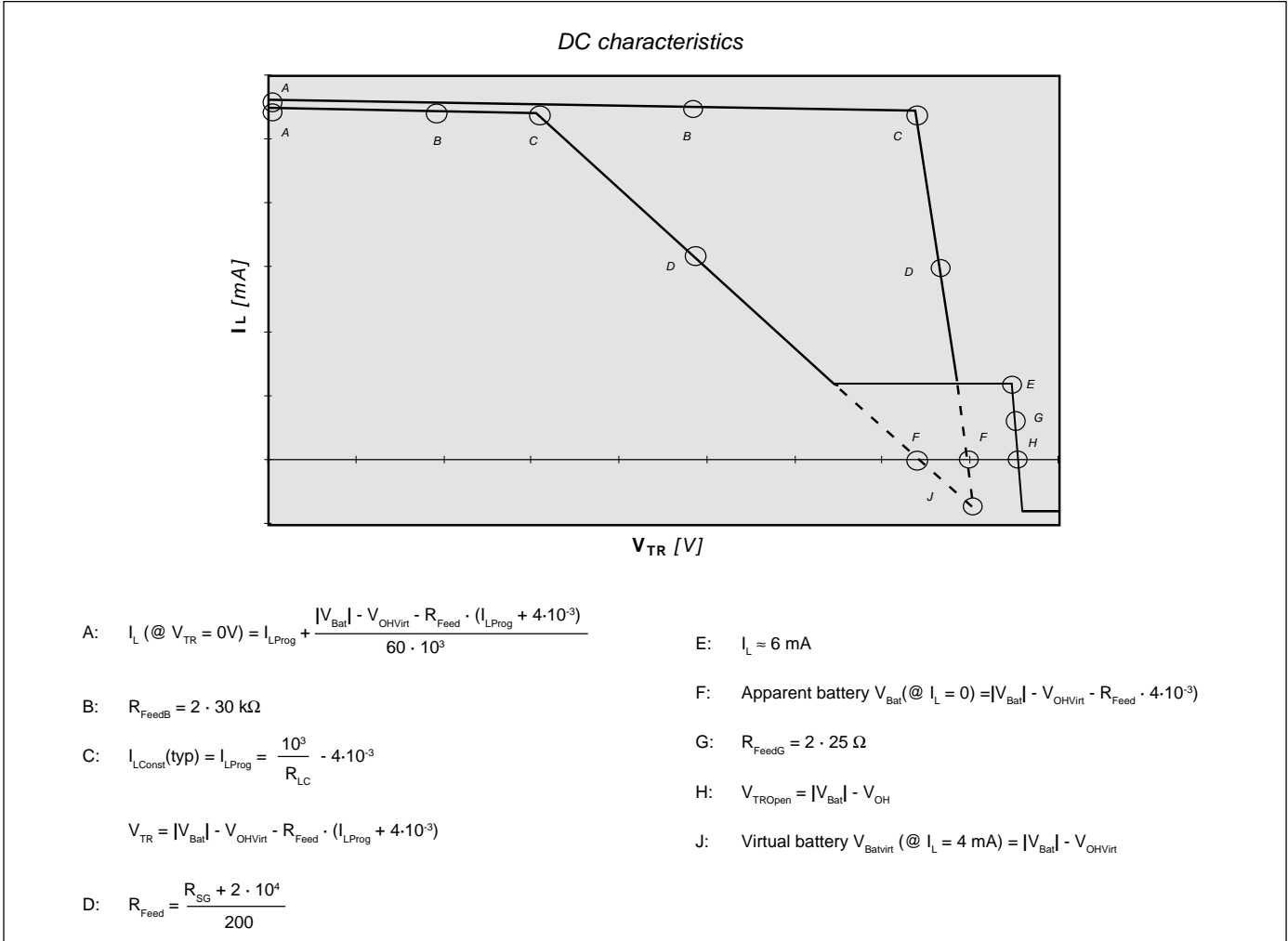

Figure 13. Battery Feed characteristics (without the protection resistors on the line).

Loop Monitoring Functions

The loop current, ground key and ring trip detectors report their status through a common output, DET. The detector to be connected to DET is selected via the three bit wide control interface C1, C2 and C3. Please refer to section Control Inputs for a description of the control interface.

Loop Current Detector

The loop current detector is indicating that the telephone is off hook and that current is flowing in the loop by putting the output DET to a logical low level when selected. The loop current threshold value, I_{LTh} , at which the loop current detector changes state is programmable by selecting the value of resistor R_{LD} . R_{LD} connects between pin PLD and ground

and is calculated according to

$$R_{LD} = \frac{500}{I_{LTh}}$$

the current detector is internally filtered and is not influenced by the ac signal at the two wire side.

Ground Key Detector

The ground key detector is indicating when the ground key is pressed (active) by putting the output pin DET to a logical high level when selected. The ground key detector circuit senses the difference in TIPX and RINGX currents. When the current at the RINGX side exceeds the current at the TIPX side with the threshold value the detector is triggered. For threshold current values, please refer to the datasheet.

Ring Trip Detector

Ring trip detection is accomplished by connecting an external network to a comparator in the SLIC with inputs DT and DR. The ringing source can be balanced or unbalanced superimposed on V_b or GND. The unbalanced ringing source may be applied to either the ring lead or the tip lead with return via the other wire. A ring relay driven by the SLIC ring relay driver connects the ringing source to tip and ring.

The ring trip function is based on a polarity change at the comparator input when the line goes off-hook. In the on-hook state no dc current flows through the loop and the voltage at comparator input DT is more positive than the voltage at input DR. When the line goes off-hook, while the ring relay is energized, dc current flows and the comparator input voltage reverses polarity.

Figure 12 gives an example of a ring

trip detection network. This network is applicable, when the ring voltage superimposed on V_B and is injected on the ring lead of the two-wire port. The dc voltage across sense resistor R_{RT} is monitored by the ring trip comparator input DT and DR via the network R_1, R_2, R_3, R_4, C_1 and C_2 . With the line on-hook (no dc current) DT is more positive than DR and the DET output will report logic level high, i.e. the detector is not tripped. When the line goes off-hook, while ringing, a dc current will flow through the loop including sense resistor R_{RT} and will cause input DT to become more negative than input DR. This changes output DET to logic level low, i.e. tripped detector condition. The system controller (or line card processor) responds by de-energizing the ring relay, i.e. ring trip.

Complete filtering of the 20 Hz ac component at terminal DT and DR is not necessary. A toggling DET output can be examined by a software routine to determine the duty cycle. When the DET output is at logic level low for more than half the time, off-hook condition is indicated.

Relay driver

The PBL 386 40/2 SLIC incorporates a ring relay driver designed as open collector (npn) with a current sinking capability of 50 mA. The drive transistor emitter is connected to BGND. The relay driver has an internal zener diode clamp for inductive kick-back voltages. Care must be taken when using the relay driver together with relays that have high impedance.

Control Inputs

The PBL 386 40/2 SLIC have three digital control inputs, C1, C2 and C3.

A decoder in the SLIC interprets the control input condition and sets up the commanded operating state.

C1 to C3 are internal pull-up inputs.

Open Circuit State

In the Open Circuit State the TIPX and RINGX line drive amplifiers as well as other circuit blocks are powered down. This causes the SLIC to present a high impedance to the line. Power dissipation is at a minimum and no detectors are active.

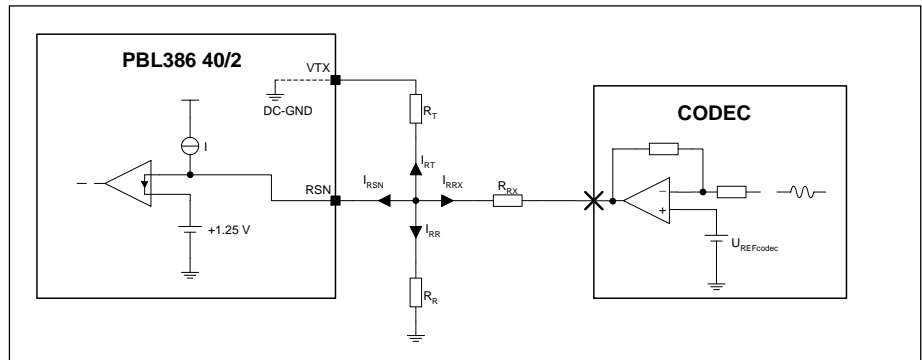

Figure 14. CODEC receive interface.

Ringing State

The ring relay driver and the ring trip detector are activated and the ring trip detector is indicating off hook with a logic low level at the detector output. The SLIC is in the active normal state.

Active States

TIPX is the terminal closest to ground and sources loop current while RINGX is the more negative terminal and sinks loop current. Vf signal transmission is normal. The loop current or the ground key detector is activated. The loop current detector is indicating off hook with a logic low level and the ground key detector is indicating active ground key with a logic high level present at the detector output.

In PBL 386 40/2 a line voltage measurement feature is available in the active state, which may be used for line length estimations or for line test purposes. The line voltage is presented on the detector output as a pulse at logic high level with a pulsewidth of 5.5 μ s/V. To start the line voltage measurement this mode has to be entered from the Active State with the loop or ground key detector active. The pulse presented at the DET output proportional to the line voltage starts when entering the line voltage measuring mode.

Tip Open State

Tip Open State is used for ground start signalling.

In this state the SLICs present a high impedance to the line on the TIPX pin and the programmed dc characteristic, with the longitudinal current compensation (see section Longitudinal Impedance) not active, to the line on the RINGX pin.

The loop current detector is active.

Active Polarity Reversal State

TIPX and RINGX polarity is reversed from the Active State: RINGX is the terminal closest to ground and sources loop current while TIPX is the more negative terminal and sinks current. Vf signal transmission is normal. The loop current or the ground key detector is activated. The loop current detector is indicating off hook with a logic low level and the ground key detector is indicating active ground key with a logic high level present at the detector output.

Overvoltage Protection

The PBL 386 40/2 SLIC must be protected against overvoltages on the telephone line caused by lightning, ac power contact and induction. Refer to Maximum Ratings, TIPX and RINGX terminals, for maximum allowable continuous and transient ratings that may be applied to the SLIC.

Secondary Protection

The circuit shown in figure 12 utilizes series resistors together with a programmable overvoltage protector (e.g. PowerInnovations TISPPBL2), serving as a secondary protection.

The TISP PBL2 is a dual forward-conducting buffered p-gate overvoltage protector. The protector gate references the protection (clamping) voltage to negative supply voltage (i.e. the battery voltage, V_B). As the protection voltage will track the negative supply voltage the overvoltage stress on the SLIC is minimized.

Positive overvoltages are clamped to ground by a diode. Negative overvoltages are initially clamped close to the SLIC negative supply rail voltage and the

protector will crowbar into a low voltage on-state condition, by firing an internal thyristor.

A gate decoupling capacitor, C_{GG} , is needed to carry enough charge to supply a high enough current to quickly turn on the thyristor in the protector. C_{GG} shall be placed close to the overvoltage protection device. Without the capacitor even the low inductance in the track to the V_{Bat} supply will limit the current and delay the activation of the thyristor clamp.

The fuse resistors R_F serve the dual purposes of being non-destructive energy dissipators, when transients are clamped and of being fuses, when the line is exposed to a power cross.

If a PTC is chosen for R_F , note that it is important to always use the PTC's in series with resistors not sensitive to temperature, as the PTC will act as a capacitance for fast transients and therefore will not protect the TISP.

Power-up Sequence

No special power-up sequence is necessary except that ground has to be present before all power supply voltages.

Printed Circuit Board Layout

Care in PCB layout is essential for proper function. The components connecting to the RSN input should be placed in close proximity to that pin, so that no interference is injected into the RSN pin. Ground plane surrounding the RSN pin is advisable.

The two ground pins AGND and BGND should be connected together on the PCB at the device location.

The capacitors for the battery should be connected with short wide leads of the same length.

Ordering Information

Package	Temp. Range	Part No.
24 pin SSOP Tape & Reel	-40° - +85° C	PBL 386 40/2SHT
24 pin SOIC Tube	-40° - +85° C	PBL 386 40/2SOS
24 pin SOIC Tape & Reel	-40° - +85° C	PBL 386 40/2SOT
28 pin PLCC Tube	-40° - +85° C	PBL 386 40/2QNS
28 pin PLCC Tape & Reel	-40° - +85° C	PBL 386 40/2QNT

Information given in this data sheet is believed to be accurate and reliable. However no responsibility is assumed for the consequences of its use nor for any infringement of patents or other rights of third parties which may result from its use. No license is granted by implication or otherwise under any patent or patent rights of Ericsson Microelectronics AB. These products are sold only according to Ericsson Microelectronics AB' general conditions of sale, unless otherwise confirmed in writing.

Specifications subject to change without notice.

1522-PBL 386 40/2 Uen Rev. B

© Ericsson Microelectronics AB 2000

This product is an original Ericsson product protected by US, Europe and other patents.



Ericsson Microelectronics AB

SE-164 81 Kista-Stockholm, Sweden

Telephone: +46 8 757 50 00