

# DATA SHEET

## **TEA6300** **TEA6300T** Sound fader control circuit

Product specification  
File under Integrated Circuits, IC01

May 1990

## Sound fader control circuit

TEA6300  
TEA6300T

### GENERAL DESCRIPTION

The Sound Fader Control circuit (SOFAC) is an I<sup>2</sup>C-bus controlled preamplifier for car radios.



### Features

- Source selector for three stereo inputs
- Inputs and outputs for noise reduction circuits
- Volume and balance control; control range of 86 dB in steps of 2 dB
- Bass and treble control from + 15 dB (treble 12 dB) to -12 dB in steps of 3 dB
- Fader control from 0 dB to -30 dB in steps of 2 dB
- Fast muting
- Low noise suitable for DOLBY\* B and C NR (noise reduction)
- Signal handling suitable for compact disc
- I<sup>2</sup>C-bus control for all functions
- ESD protected

### QUICK REFERENCE DATA

SYMBOL	PARAMETER	MIN.	TYP.	MAX.	UNIT
V <sub>CC</sub>	Supply voltage	7,0	8,5	13,2	V
V <sub>i(rms)</sub>	Input sensitivity for full power at the output stage	-	50	-	mV
V <sub>i(rms)</sub>	Input signal handling	-	1,65	-	V
f <sub>r</sub>	Frequency response	35	-	20 000	Hz
α <sub>CS</sub>	Channel separation; f = 250 Hz to 10 kHz	70	92	-	dB
THD	Total harmonic distortion	-	0,05	-	%
(S+N)/N	Signal plus noise-to-noise ratio	-	80	-	dB
T <sub>amb</sub>	Operating ambient temperature range	-40	-	+ 85	°C

\* Dolby is a registered trademark of Dolby Laboratories Licensing Corporation, San Francisco, California (U.S.A.).

### PACKAGE OUTLINES

28-lead dual in-line; plastic (SOT117); SOT117-1; 1996 August 15.

28-lead mini-pack; plastic (SO28; SOT136A); SOT136-1; 1996 August 15.

Sound fader control circuit

TEA6300  
TEA6300T

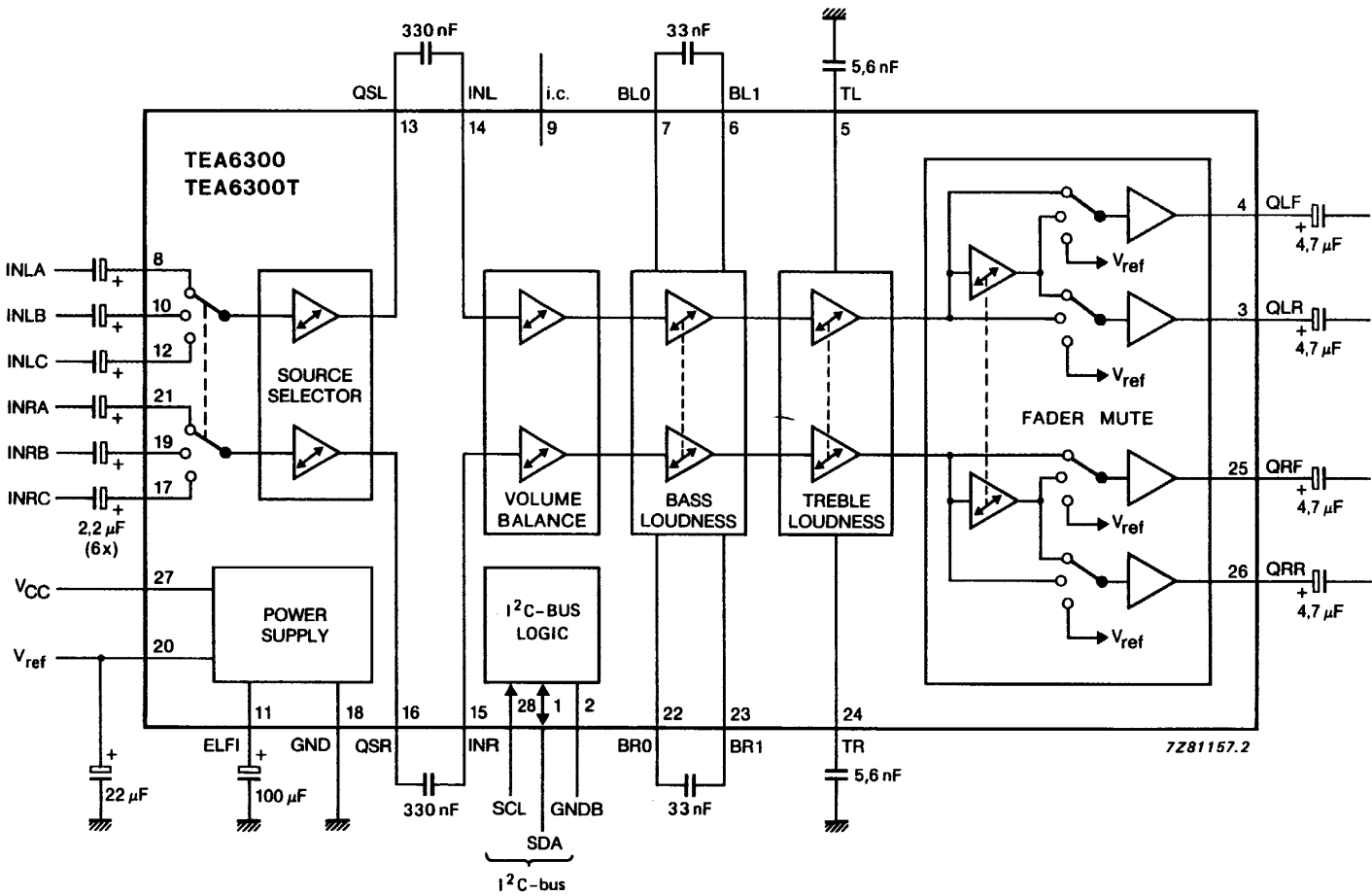

Fig.1 Block diagram.

## Sound fader control circuit

TEA6300  
TEA6300T

## PINNING

1	SDA	serial data input/output (I <sup>2</sup> C-bus)
2	GNDB	ground for I <sup>2</sup> C-bus terminals
3	QLR	output left rear
4	QLF	output left front
5	TL	treble control capacitor; left channel
6	BL1	bass control capacitor; left channel
7	BLO	bass control capacitor; left channel
8	INLA	input left source A
9	i.c.	internally connected
10	INLB	input left source B
11	ELFI	electronic filtering for supply
12	INLC	input left source C
13	QSL	output source selector left
14	INL	input left control part
15	INR	input right control part
16	QSR	output source selector right
17	INRC	input right source C
18	GND	ground
19	INRB	input right source B
20	V <sub>ref</sub>	reference voltage (1/2 V <sub>CC</sub> )
21	INRA	input right source A
22	BRO	bass control capacitor; right channel
23	BR1	bass control capacitor; right channel
24	TR	treble control capacitor; right channel
25	QRF	output right front
26	QRR	output right rear
27	V <sub>CC</sub>	supply voltage
28	SCL	serial clock input (I <sup>2</sup> C-bus)

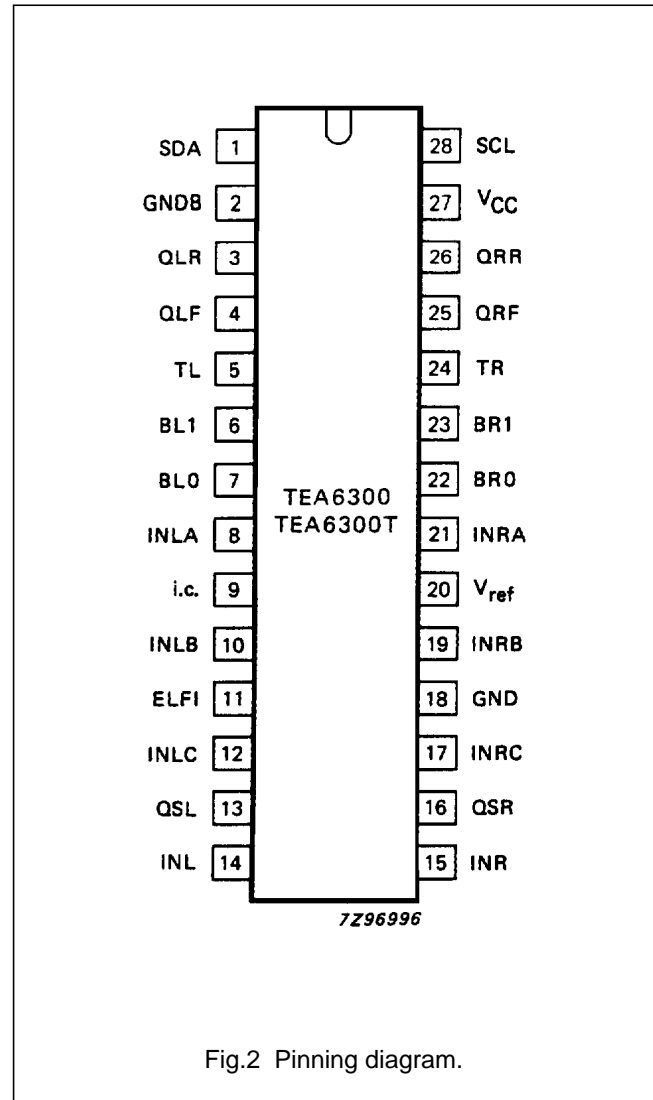

---

**Sound fader control circuit**
**TEA6300**  
**TEA6300T**

---

**FUNCTIONAL DESCRIPTION**

The source selector selects three stereo channels –RF part (AM/FM), recorder and compact disc. As the outputs of the source selector and the inputs of the main control part are available, additional circuits such as compander and equalizer systems may be inserted into the signal path. The AC signal setting is performed by resistor chains in combination with multi-input operational amplifiers. The advantage of this principle is the combination of low noise, low distortion and a high dynamic range for the circuit.

The separate volume controls of the left and the right channel facilitate correct balance control. The range and balance control is software programmable.

Because the TEA6300 has four outputs a low-level fader is included. The fader control is independent of the volume control and an extra mute position is built in for the front, the rear or for all channels. The last function may be used for muting during preset selection. An extra pop suppression circuit is built in for pop-free switching on and off. As all switching and control functions are controllable via the two-wire I<sup>2</sup>C-bus, no external interface between the microcomputer and the TEA6300 is required.

The on-chip power-on-reset sets the TEA6300 to the general mute mode.

**RATINGS**

Limiting values in accordance with the Absolute Maximum System (IEC 134)

SYMBOL	PARAMETER	MIN.	MAX.	UNIT
V <sub>CC</sub>	Supply voltage (pin 27-18)	–	16	V
P <sub>tot</sub>	Maximum power dissipation	–	1	W
T <sub>stg</sub>	Storage temperature range	–55	+150	°C
T <sub>amb</sub>	Operating ambient temperature range	–40	+ 85	°C

## Sound fader control circuit

TEA6300  
TEA6300T**CHARACTERISTICS** $V_{CC} = 8,5 \text{ V}$ ;  $R_S = 600 \ \Omega$ ;  $R_L = 10 \text{ k}\Omega$ ;  $f = 1 \text{ kHz}$ ;  $T_{amb} = 25 \text{ }^\circ\text{C}$ ; test circuit Fig.10; unless otherwise specified

SYMBOL	PARAMETER	MIN.	TYP.	MAX.	UNIT
$V_{CC}$	Supply voltage	7,0	8,5	13,2	V
$I_{CC}$	Supply current	–	26	–	mA
$I_{CC}$	Supply current at 8,5 V	–	–	33	mA
$I_{CC}$	Supply current at 13,2 V	–	–	44	mA
$V_{DC}$	DC voltage inputs, outputs and reference	0,45	0,5	0,55	$V_{CC}$
$V_{REF}$	Internal reference voltage (pin 20) $V_{ref} = 0,5 V_{CC}$	–	4,25	–	V
$G_v$	Maximum voltage gain bass and treble linear, fader off	19	20	21	dB
$V_{o(rms)}$	Output voltage level for $P_{max}$ at the output stage	–	500	–	mV
$V_{o(rms)}$	for start of clipping	–	1000	–	mV
$V_{i(rms)}$	Input sensitivity at $V_o = 500 \text{ mV}$	–	50	–	mV
$f_r$	Frequency response bass and treble linear; roll-off frequency –1 dB	35	–	20 000	Hz
$\alpha_{CS}$	Channel separation $G_v = 0 \text{ dB}$ ; bass and treble linear; frequency range 250 Hz to 10 kHz	70	92	–	dB
THD	Total harmonic distortion frequency range 20 Hz to 12,5 kHz $V_i = 50 \text{ mV}$ ; $G_v = 20 \text{ dB}$	–	0,1	0,3	%
THD	$V_i = 500 \text{ mV}$ ; $G_v = 0 \text{ dB}$	–	0,05	0,2	%
THD	$V_i = 1,6 \text{ V}$ ; $G_v = -10 \text{ dB}$	–	0,2	0,5	%
RR <sub>100</sub>	Ripple rejection $V_{r(rms)} < 200 \text{ mV}$ ; $G_v = 0 \text{ dB}$ ; bass and treble linear; at $f = 100 \text{ Hz}$	–	70	–	dB
RR <sub>range</sub>	at $f = 40 \text{ Hz to } 12,5 \text{ kHz}$	–	60	–	dB

## Sound fader control circuit

TEA6300  
TEA6300T

SYMBOL	PARAMETER	MIN.	TYP.	MAX.	UNIT
	Signal plus noise-to-noise ratio bass and treble linear; notes 1 and 2 CCIR 468-2 weighted; quasi peak				
$(S + N)/N$	$V_i = 50 \text{ mV}; V_o = 46 \text{ mV}; P_o = 50 \text{ mW}$	–	65	–	dB
$(S + N)/N$	$V_i = 500 \text{ mV}; V_o = 45 \text{ mV}; P_o = 50 \text{ mW}$	–	67	–	dB
$(S + N)/N$	$V_i = 50 \text{ mV}; V_o = 200 \text{ mV}; P_o = 1 \text{ W}$	65	70	–	dB
$(S + N)/N$	$V_i = 500 \text{ mV}; V_o = 200 \text{ mV}; P_o = 1 \text{ W}$	65	78	–	dB
$(S + N)/N$	$V_i = 50 \text{ mV}; V_o = 500 \text{ mV}; P_o = 6 \text{ W}$	–	70	–	dB
$(S + N)/N$	$V_i = 500 \text{ mV}; V_o = 500 \text{ mV}; P_o = 6 \text{ W}$	–	85	–	dB
	Noise output power mute position, only contribution of TEA6300; power amplifier for 25 W	–	–	10	nW
	Crosstalk ( $20 \log V_{\text{bus(p-p)}}/V_{o(\text{rms})}$ ) between bus inputs and signal outputs				
$\alpha_B$	$G_V = 0 \text{ dB}$ ; bass and treble linear	–	110	–	dB
<b>Source selector</b>					
$Z_i$	Input impedance	20	30	40	k $\Omega$
$Z_o$	Output impedance	–	–	100	$\Omega$
$R_L$	Output load resistance	10	–	–	k $\Omega$
$C_L$	Output load capacity	0	–	200	pF
	Input isolation not selected source; frequency range 40 Hz to 12,5 kHz	–	80	–	dB
$\alpha_S$	Voltage gain $R_L \geq 10 \text{ k}\Omega$	–	0	–	dB
$V_{b \text{ int}}/V_{\text{ref}}$	Internal bias voltage ratio	–	1	–	
	Maximum input voltage level (RMS value)				
$V_{i(\text{rms})}$	THD < 0,5%	–	1,65	–	V
$V_{i(\text{rms})}$	THD < 0,5%; $V_{CC} = 7,5 \text{ V}$	–	1,5	–	V
	Total harmonic distortion				
THD	$V_i = 500 \text{ mV}; R_L = 10 \text{ k}\Omega$	–	–	0,1	%
	Noise output voltage weighted CCIR 468-2, quasi peak	–	9	20	$\mu\text{V}$
$V_{no}$	DC offset voltage between any inputs	–	–	10	mV
$V_o$					

## Sound fader control circuit

TEA6300  
TEA6300T

SYMBOL	PARAMETER	MIN.	TYP.	MAX.	UNIT
<b>Control part</b>					
$Z_i$	Source selector disconnected, source resistance 600 $\Omega$ Input impedance	35	50	65	k $\Omega$
$Z_o$	Output impedance	–	100	150	$\Omega$
$R_L$	Output load resistance	5	–	–	k $\Omega$
$C_L$	Output load capacity	0	–	2500	pF
$V_{i(rms)}$	Maximum input voltage THD < 0,5%; $G_v = -10$ dB; bass and treble linear	–	2,0	–	V
$V_{no}$	Noise output voltage weighted acc CCIR 468-2, quasi-peak, bass and treble linear, fader off $G_v = 20$ dB	–	110	220	$\mu$ V
$V_{no}$	$G_v = 0$ dB	–	25	50	$\mu$ V
$V_{no}$	$G_v = -66$ dB	–	19	38	$\mu$ V
$V_{no}$	mute position	–	11	22	$\mu$ V
<b>Volume control</b>					
$G_c$	Continuous control range	–	86	–	dB
	Step resolution	–	2	–	dB
$\Delta G_a$	Attenuator set error ( $G_v = +20$ to $-50$ dB)	–	–	2	dB
$\Delta G_a$	Attenuator set error ( $G_v = +20$ to $-66$ dB)	–	–	3	dB
$\Delta G_t$	Gain tracking error balance in mid position, bass and treble linear	–	–	2	dB
$\alpha_m$	Mute attenuation	72	90	–	dB
<b>DC step offset</b>					
	Between any adjoining step and any step to mute $G_v = 0$ to $-66$ dB	–	0,2	10	mV
	$G_v = 20$ to $0$ dB	–	2	15	mV
	In any treble and fader position $G_v = 0$ to $-66$ dB	–	–	10	mV
	In any bass position $G_v = 0$ to $-66$ dB	–	–	20	mV



## Sound fader control circuit

TEA6300  
TEA6300T

SYMBOL	PARAMETER	MIN.	TYP.	MAX.	UNIT
<b>Bass control</b>					
$G_b$	Bass control range f = 40 Hz; maximum boost	14	15	16	dB
$G_b$	f = 40 Hz; maximum attenuation	11	12	13	dB
	Step resolution	–	3	–	dB
	Step error	–	–	0,5	dB
<b>Treble control</b>					
$G_t$	Treble control range f = 15 kHz; maximum boost	11	12	13	dB
$G_t$	f = 15 kHz; maximum attenuation	11	12	13	dB
$G_t$	f > 15 kHz; maximum boost	–	–	15	dB
	Step resolution	–	3	–	dB
	Step error	–	–	0,5	dB
<b>Fader control</b>					
$G_f$	Continuous attenuation fader control range	–	30	–	dB
	Step resolution	–	2	–	dB
	Attenuator set error	–	–	1,5	dB
$\alpha_m$	Mute attenuation	74	84	–	dB
<b>Digital part</b>					
<i>Bus terminals</i>					
$V_{IH}$	Input voltage HIGH	3	–	12	V
$V_{IL}$	LOW	–0,3	–	+ 1,5	V
	Input current				
$I_{IH}$	HIGH	–10	–	+10	$\mu$ A
$I_{IL}$	LOW	–10	–	+10	$\mu$ A
$V_{OL}$	Output voltage LOW; $I_L = 3$ mA	–	–	0,4	V
<i>AC characteristics</i>	In accordance with the I2C-bus specification				
<i>Power-on-Reset</i>					
	When RESET is active the GMU (general mute) bit is set and the I <sup>2</sup> C-bus receiver is in RESET position				
$V_{CC}$	Increasing supply voltage start of reset	–	–	2,5	V
$V_{CC}$	end of reset	5,2	6,0	6,8	V
$V_{CC}$	Decreasing supply voltage; start of reset	4,2	5,0	5,8	V

**Notes to the characteristics**

- The indicated values for output power assume a 6 W power amplifier with 20 dB gain, connected to the output of the

Sound fader control circuit

TEA6300  
TEA6300T

circuit. Signal-to-noise ratios exclude noise contribution of the power amplifier.

2. Signal-to-noise ratios on a CCIR 468-2 average meter reading are 4,5 dB better than on CCIR 468-2 quasi peak.

I<sup>2</sup>C-BUS FORMAT

S	SLAVE ADDRESS	A	SUBADDRESS	A	DATA	A	P
---	---------------	---	------------	---	------	---	---

- S = start condition
- SLAVE ADDRESS = 1000 0000
- A = acknowledge, generated by the slave
- SUBADDRESS = see Table 1
- DATA = see Table 1
- P = STOP condition

If more than 1 byte of DATA is transmitted, then auto-increment of the subaddress is performed.

Table 1 I<sup>2</sup>C-bus; subaddress/data

FUNCTION	SUBADDRESS	DATA							
		D7	D6	D5	D4	D3	D2	D1	D0
volume left	00000000	X	X	VL5	VL4	VL3	VL2	VL1	VL0
volume right	00000001	X	X	VR5	VR4	VR3	VR2	VR1	VR0
bass	00000010	X	X	X	X	BA3	BA2	BA1	BA0
treble	00000011	X	X	X	X	TR3	TR2	TR1	TR0
fader	00000100	X	X	MFN	FCH	FA3	FA2	FA1	FA0
switch	00000101	GMU	X	X	X	X	SCC	SCB	SCA

Function of the bits:

- VL0 to VL5 volume control left
- VR0 to VR5 volume control right
- BA0 to BA3 bass control
- TR0 to TR3 treble control
- FA0 to FA3 fader control
- FCH select fader channel (front or rear)
- MFN mute control of the selected fader channel (front or rear)
- SCA to SCC source selector control
- GMU mute control (general mute)  
for the outputs QLF, QLR, QRF and QRR
- X don't care bits (logic 1 during testing)

Sound fader control circuit

TEA6300  
TEA6300T

**Table 2** Bass setting

G <sub>v</sub> DB	DATA			
	BA3	BA2	BA1	BA0
+15	1	1	1	1
+15	1	1	1	0
+15	1	1	0	1
+15	1	1	0	0
+12	1	0	1	1
+ 9	1	0	1	0
+ 6	1	0	0	1
+ 3	1	0	0	0
0	0	1	1	1
- 3	0	1	1	0
- 6	0	1	0	1
- 9	0	1	0	0
-12	0	0	1	1
-12	0	0	1	0
-12	0	0	0	1
-12	0	0	0	0

**Table 3** Treble setting

G <sub>v</sub> DB	DATA			
	TR3	TR2	TR1	TR0
+12	1	1	1	1
+12	1	1	1	0
+12	1	1	0	1
+12	1	1	0	0
+12	1	0	1	1
+ 9	1	0	1	0
+ 6	1	0	0	1
+ 3	1	0	0	0
0	0	1	1	1
- 3	0	1	1	0
- 6	0	1	0	1
- 9	0	1	0	0
-12	0	0	1	1
-12	0	0	1	0
-12	0	0	0	1
-12	0	0	0	0

Sound fader control circuit

TEA6300  
TEA6300T

**Table 4** Volume setting LEFT

G <sub>V</sub> DB	DATA						G <sub>V</sub> DB	DATA					
	VL5	VL4	VL3	VL2	VL1	VL0		VL5	VL4	VL3	VL2	VL1	VL0
20	1	1	1	1	1	1	-30	1	0	0	1	1	0
18	1	1	1	1	1	0	-32	1	0	0	1	0	1
16	1	1	1	1	0	1	-34	1	0	0	1	0	0
14	1	1	1	1	0	0	-36	1	0	0	0	1	1
12	1	1	1	0	1	1	-38	1	0	0	0	1	0
10	1	1	1	0	1	0	-40	1	0	0	0	0	1
8	1	1	1	0	0	1	-42	1	0	0	0	0	0
6	1	1	1	0	0	0	-44	0	1	1	1	1	1
4	1	1	0	1	1	1	-46	0	1	1	1	1	0
2	1	1	0	1	1	0	-48	0	1	1	1	0	1
0	1	1	0	1	0	1	-50	0	1	1	1	0	0
-2	1	1	0	1	0	0	-52	0	1	1	0	1	1
-4	1	1	0	0	1	1	-54	0	1	1	0	1	0
-6	1	1	0	0	1	0	-56	0	1	1	0	0	1
-8	1	1	0	0	0	1	-58	0	1	1	0	0	0
-10	1	1	0	0	0	0	-60	0	1	0	1	1	1
-12	1	0	1	1	1	1	-62	0	1	0	1	1	0
-14	1	0	1	1	1	0	-64	0	1	0	1	0	1
-16	1	0	1	1	0	1	-66	0	1	0	1	0	0
-18	1	0	1	1	0	0	mute left	0	1	0	0	1	1
-20	1	0	1	0	1	1	mute left	0	1	0	0	1	0
-22	1	0	1	0	1	0	.				.		
-24	1	0	1	0	0	1	.				.		
-26	1	0	1	0	0	0	.				.		
-28	1	0	0	1	1	1	mute left	0	0	0	0	0	0

Sound fader control circuit

TEA6300  
TEA6300T

**Table 5** Volume setting RIGHT

G <sub>v</sub> DB	DATA					
	VR5	VR4	VR3	VR2	VR1	VR0
20	1	1	1	1	1	1
18	1	1	1	1	1	0
16	1	1	1	1	0	1
14	1	1	1	1	0	0
12	1	1	1	0	1	1
10	1	1	1	0	1	0
8	1	1	1	0	0	1
6	1	1	1	0	0	0
4	1	1	0	1	1	1
2	1	1	0	1	1	0
0	1	1	0	1	0	1
- 2	1	1	0	1	0	0
- 4	1	1	0	0	1	1
- 6	1	1	0	0	1	0
- 8	1	1	0	0	0	1
-10	1	1	0	0	0	0
-12	1	0	1	1	1	1
-14	1	0	1	1	1	0
-16	1	0	1	1	0	1
-18	1	0	1	1	0	0
-20	1	0	1	0	1	1
-22	1	0	1	0	1	0
-24	1	0	1	0	0	1
-26	1	0	1	0	0	0
-28	1	0	0	1	1	1

G <sub>v</sub> DB	DATA					
	VR5	VR4	VR3	VR2	VR1	VR0
-30	1	0	0	1	1	0
-32	1	0	0	1	0	1
-34	1	0	0	1	0	0
-36	1	0	0	0	1	1
-38	1	0	0	0	1	0
-40	1	0	0	0	0	1
-42	1	0	0	0	0	0
-44	0	1	1	1	1	1
-46	0	1	1	1	1	0
-48	0	1	1	1	0	1
-50	0	1	1	1	0	0
-52	0	1	1	0	1	1
-54	0	1	1	0	1	0
-56	0	1	1	0	0	1
-58	0	1	1	0	0	0
-60	0	1	0	1	1	1
-62	0	1	0	1	1	0
-64	0	1	0	1	0	1
-66	0	1	0	1	0	0
mute right	0	1	0	0	1	1
mute right	0	1	0	0	1	0
.				.		
.				.		
.				.		
mute right	0	0	0	0	0	0

## Sound fader control circuit

TEA6300  
TEA6300T

Table 6 Fader function

SETTING		DATA					
FRONT REAR							
DB	DB	MFN	FCH	FA3	FA2	FA1	FA0
		fader off					
0	0	1	1	1	1	1	1
0	0	0	1	1	1	1	1
		fader front					
-2	0	1	1	1	1	1	0
-4	0	1	1	1	1	0	1
-6	0	1	1	1	1	0	0
-8	0	1	1	1	0	1	1
-10	0	1	1	1	0	1	0
-12	0	1	1	1	0	0	1
-14	0	1	1	1	0	0	0
-16	0	1	1	0	1	1	1
-18	0	1	1	0	1	1	0
-20	0	1	1	0	1	0	1
-22	0	1	1	0	1	0	0
-24	0	1	1	0	0	1	1
-26	0	1	1	0	0	1	0
-28	0	1	1	0	0	0	1
-30	0	1	1	0	0	0	0
		mute front					
-80	0	0	1	1	1	1	0
.	.			.			
.	.			.			
.	.			.			
-80	0	0	1	0	0	0	0

SETTING		DATA					
FRONT REAR							
DB	DB	MFN	FCH	FA3	FA2	FA1	FA0
		fader off					
0	0	1	0	1	1	1	1
0	0	0	0	1	1	1	1
		fader rear					
0	-2	1	0	1	1	1	0
0	-4	1	0	1	1	0	1
0	-6	1	0	1	1	0	0
0	-8	1	0	1	0	1	1
0	-10	1	0	1	0	1	0
0	-12	1	0	1	0	0	1
0	-14	1	0	1	0	0	0
0	-16	1	0	0	1	1	1
0	-18	1	0	0	1	1	0
0	-20	1	0	0	1	0	1
0	-22	1	0	0	1	0	0
0	-24	1	0	0	0	1	1
0	-26	1	0	0	0	1	0
0	-28	1	0	0	0	0	1
0	-30	1	0	0	0	0	0
		mute rear					
0	-80	0	0	1	1	1	0
.	.			.			
.	.			.			
.	.			.			
0	-80	0	0	0	0	0	0

Table 7 Selected inputs

SELECTED INPUTS	DATA		
	SCC	SCB	SCA
data not allowed	1	1	1
data not allowed	1	1	0
data not allowed	1	0	1
INLC, INRC	1	0	0
data not allowed	0	1	1
INLB, INRB	0	1	0
INLA, INRA	0	0	1
data not allowed	0	0	0

Table 8 Mute control

MUTE CONTROL	DATA GMU	REMARKS
active	1	outputs QLF, QLR QRF and QRR are muted
passive	0	no general mute

Sound fader control circuit

TEA6300  
TEA6300T

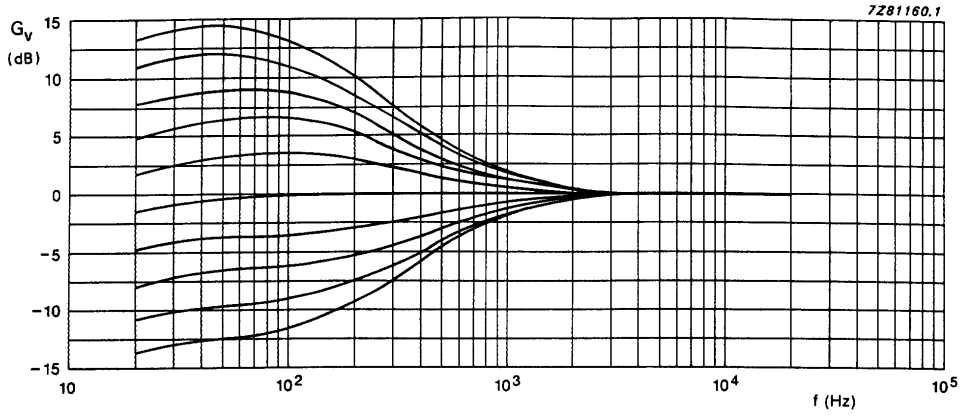

Fig.3 Bass control without T-pass filter.

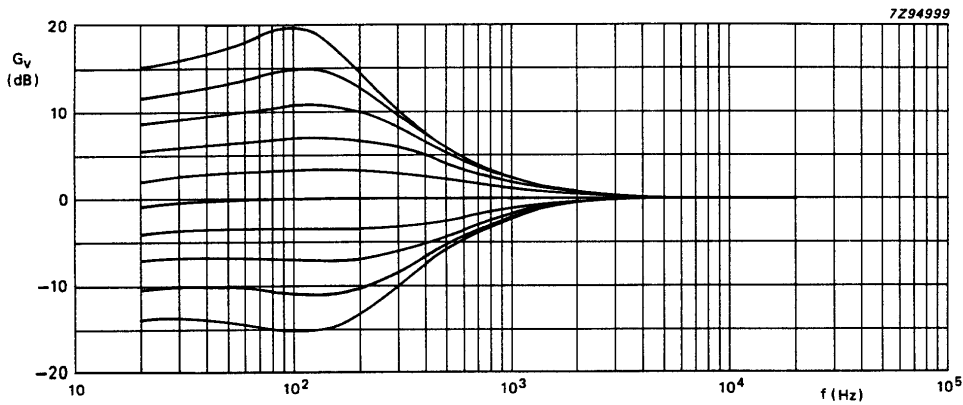
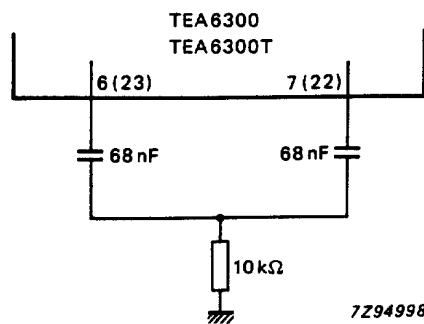

Fig.4 Bass control with T-pass filter.



Pin numbers in parentheses refer to the bass control, right channel.

Fig.5 T-pass filter.

Sound fader control circuit

TEA6300  
TEA6300T

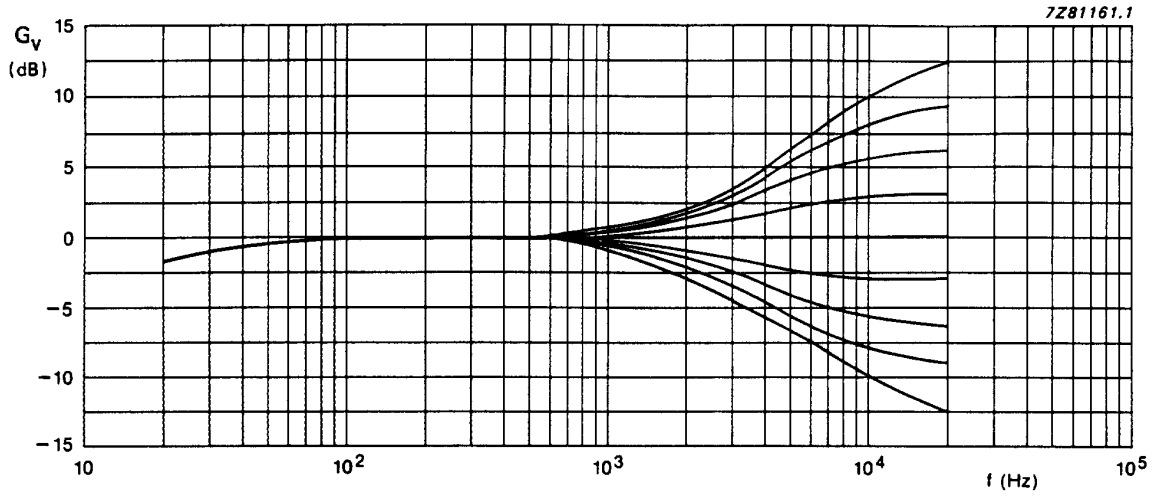

Fig.6 Treble control.

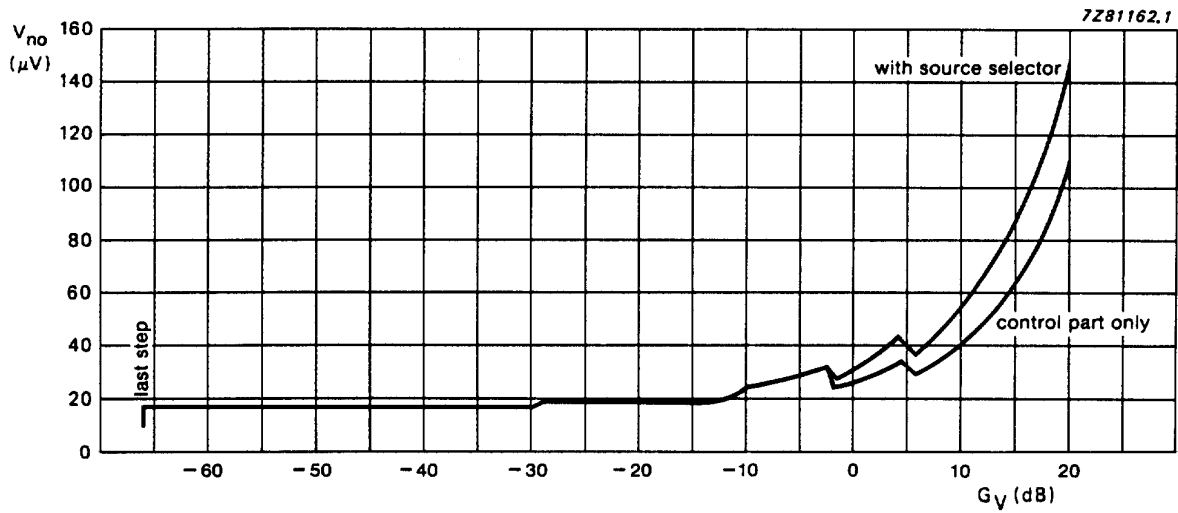

Fig.7 Output noise voltage (CCIR 468-2 weighted: quasi peak).



Sound fader control circuit

TEA6300  
TEA6300T

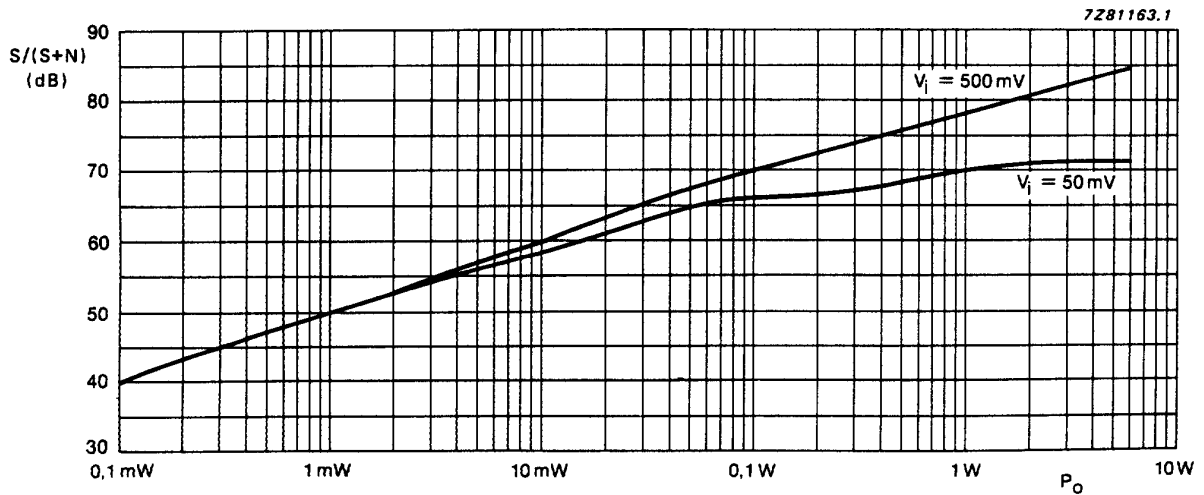

Fig.8 Signal-to-noise ratio (CCIT 468-2 weighted; quasi peak) with a 6 W power amplifier (gain 20 dB) without noise contribution of the power amplifier (see Fig.9).

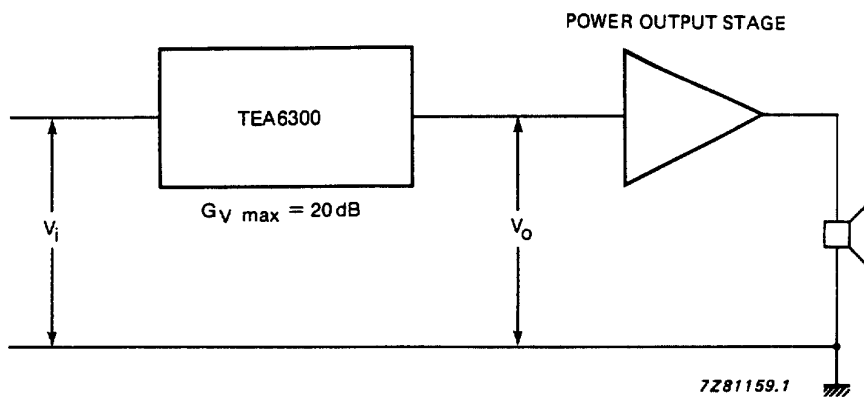

Fig.9 Recommended level diagram;  $V_{i\ min} = 50$  mV,  $V_o = 500$  mV for  $P_{max}$ .

Sound fader control circuit

TEA6300  
TEA6300T

APPLICATION INFORMATION

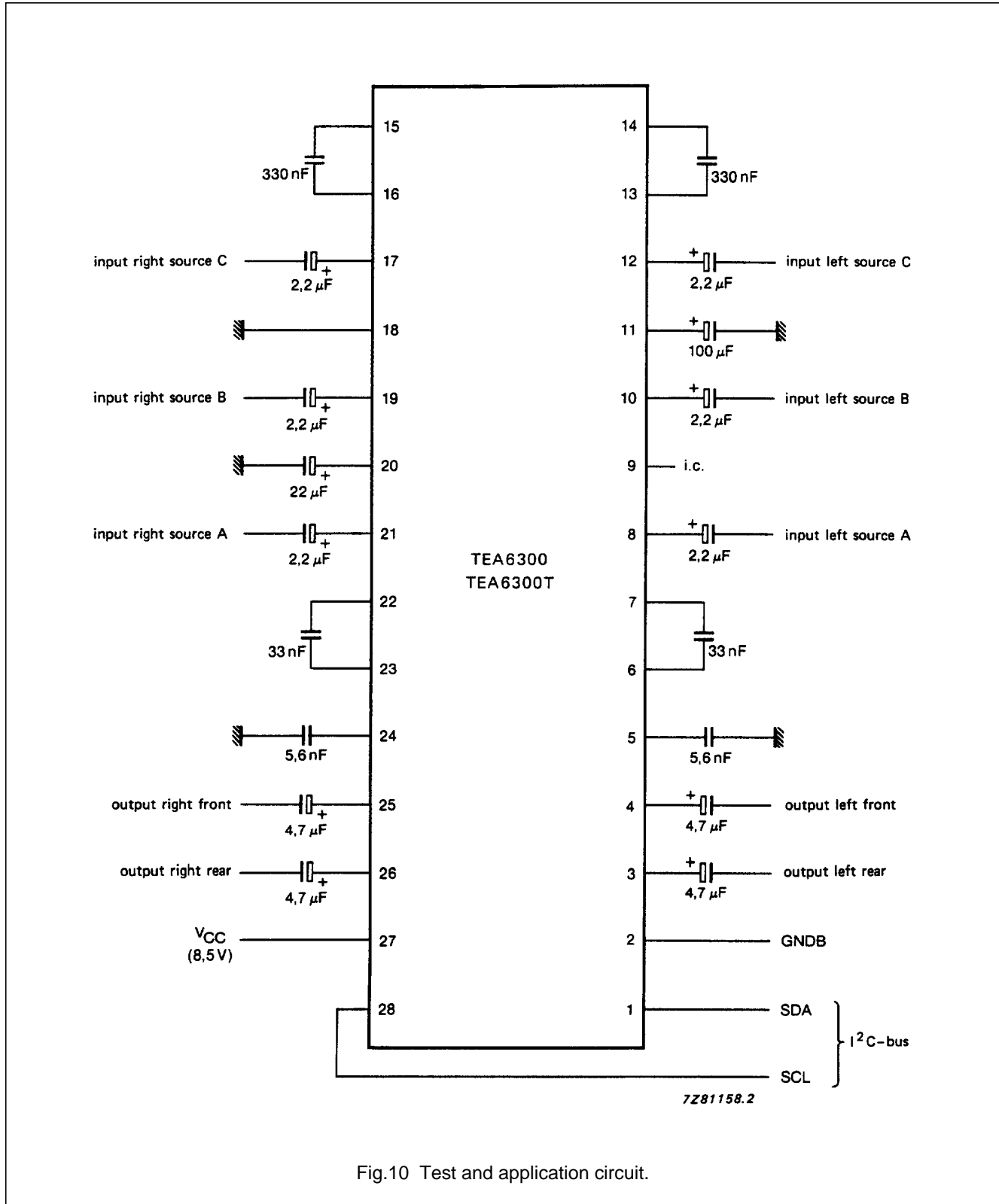

Fig.10 Test and application circuit.

Sound fader control circuit

TEA6300  
TEA6300T

PACKAGE OUTLINES

DIP28: plastic dual in-line package; 28 leads (600 mil)

SOT117-1

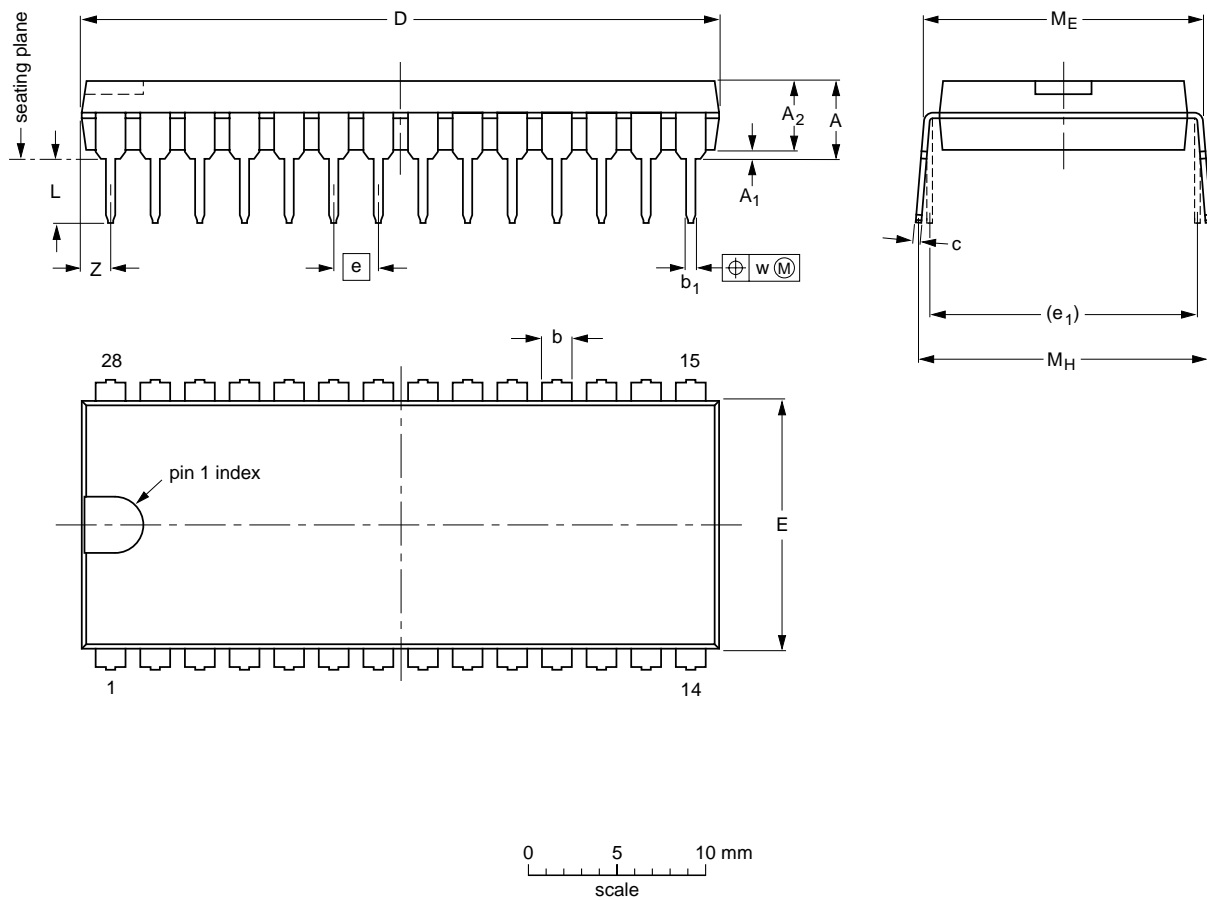

DIMENSIONS (inch dimensions are derived from the original mm dimensions)

UNIT	A max.	A <sub>1</sub> min.	A <sub>2</sub> max.	b	b <sub>1</sub>	c	D <sup>(1)</sup>	E <sup>(1)</sup>	e	e <sub>1</sub>	L	M <sub>E</sub>	M <sub>H</sub>	w	Z <sup>(1)</sup> max.
mm	5.1	0.51	4.0	1.7 1.3	0.53 0.38	0.32 0.23	36.0 35.0	14.1 13.7	2.54	15.24	3.9 3.4	15.80 15.24	17.15 15.90	0.25	1.7
inches	0.20	0.020	0.16	0.066 0.051	0.020 0.014	0.013 0.009	1.41 1.34	0.56 0.54	0.10	0.60	0.15 0.13	0.62 0.60	0.68 0.63	0.01	0.067

Note

1. Plastic or metal protrusions of 0.25 mm maximum per side are not included.

OUTLINE VERSION	REFERENCES				EUROPEAN PROJECTION	ISSUE DATE
	IEC	JEDEC	EIAJ			
SOT117-1	051G05	MO-015AH				92-11-17 95-01-14

Sound fader control circuit

TEA6300  
TEA6300T

SO28: plastic small outline package; 28 leads; body width 7.5 mm

SOT136-1

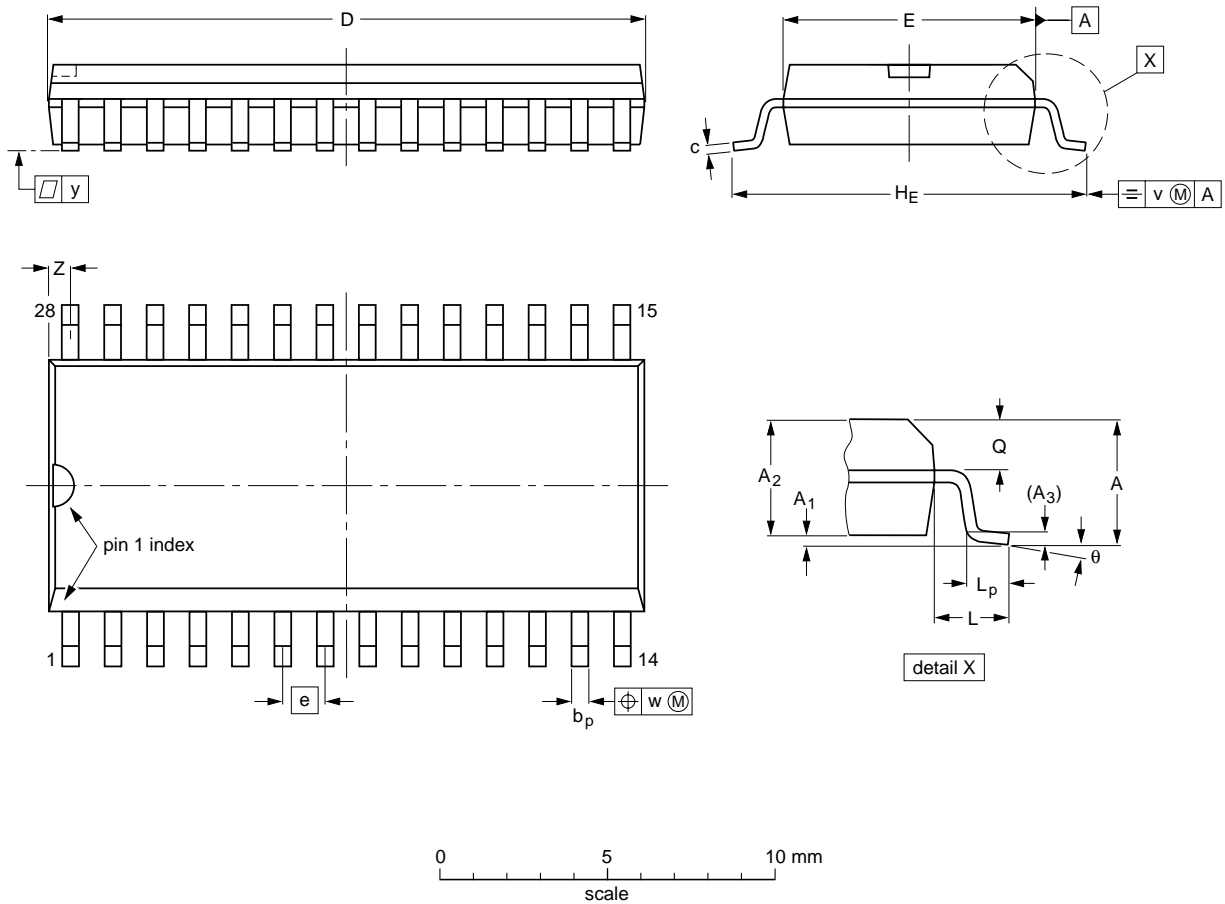

DIMENSIONS (inch dimensions are derived from the original mm dimensions)

UNIT	A max.	A <sub>1</sub>	A <sub>2</sub>	A <sub>3</sub>	b <sub>p</sub>	c	D <sup>(1)</sup>	E <sup>(1)</sup>	e	H <sub>E</sub>	L	L <sub>p</sub>	Q	v	w	y	z <sup>(1)</sup>	θ
mm	2.65	0.30 0.10	2.45 2.25	0.25	0.49 0.36	0.32 0.23	18.1 17.7	7.6 7.4	1.27	10.65 10.00	1.4	1.1 0.4	1.1 1.0	0.25	0.25	0.1	0.9 0.4	8° 0°
inches	0.10	0.012 0.004	0.096 0.089	0.01	0.019 0.014	0.013 0.009	0.71 0.69	0.30 0.29	0.050	0.419 0.394	0.055	0.043 0.016	0.043 0.039	0.01	0.01	0.004	0.035 0.016	

Note

1. Plastic or metal protrusions of 0.15 mm maximum per side are not included.

OUTLINE VERSION	REFERENCES				EUROPEAN PROJECTION	ISSUE DATE
	IEC	JEDEC	EIAJ			
SOT136-1	075E06	MS-013AE				95-01-24 97-05-22

## Sound fader control circuit

TEA6300  
TEA6300T

### SOLDERING

#### Introduction

There is no soldering method that is ideal for all IC packages. Wave soldering is often preferred when through-hole and surface mounted components are mixed on one printed-circuit board. However, wave soldering is not always suitable for surface mounted ICs, or for printed-circuits with high population densities. In these situations reflow soldering is often used.

This text gives a very brief insight to a complex technology. A more in-depth account of soldering ICs can be found in our "IC Package Databook" (order code 9398 652 90011).

#### DIP

##### SOLDERING BY DIPPING OR BY WAVE

The maximum permissible temperature of the solder is 260 °C; solder at this temperature must not be in contact with the joint for more than 5 seconds. The total contact time of successive solder waves must not exceed 5 seconds.

The device may be mounted up to the seating plane, but the temperature of the plastic body must not exceed the specified maximum storage temperature ( $T_{stg\ max}$ ). If the printed-circuit board has been pre-heated, forced cooling may be necessary immediately after soldering to keep the temperature within the permissible limit.

##### REPAIRING SOLDERED JOINTS

Apply a low voltage soldering iron (less than 24 V) to the lead(s) of the package, below the seating plane or not more than 2 mm above it. If the temperature of the soldering iron bit is less than 300 °C it may remain in contact for up to 10 seconds. If the bit temperature is between 300 and 400 °C, contact may be up to 5 seconds.

#### SO

##### REFLOW SOLDERING

Reflow soldering techniques are suitable for all SO packages.

Reflow soldering requires solder paste (a suspension of fine solder particles, flux and binding agent) to be applied to the printed-circuit board by screen printing, stencilling or pressure-syringe dispensing before package placement.

Several techniques exist for reflowing; for example, thermal conduction by heated belt. Dwell times vary between 50 and 300 seconds depending on heating method. Typical reflow temperatures range from 215 to 250 °C.

Preheating is necessary to dry the paste and evaporate the binding agent. Preheating duration: 45 minutes at 45 °C.

##### WAVE SOLDERING

Wave soldering techniques can be used for all SO packages if the following conditions are observed:

- A double-wave (a turbulent wave with high upward pressure followed by a smooth laminar wave) soldering technique should be used.
- The longitudinal axis of the package footprint must be parallel to the solder flow.
- The package footprint must incorporate solder thieves at the downstream end.

During placement and before soldering, the package must be fixed with a droplet of adhesive. The adhesive can be applied by screen printing, pin transfer or syringe dispensing. The package can be soldered after the adhesive is cured.

Maximum permissible solder temperature is 260 °C, and maximum duration of package immersion in solder is 10 seconds, if cooled to less than 150 °C within 6 seconds. Typical dwell time is 4 seconds at 250 °C.

A mildly-activated flux will eliminate the need for removal of corrosive residues in most applications.

##### REPAIRING SOLDERED JOINTS

Fix the component by first soldering two diagonally-opposite end leads. Use only a low voltage soldering iron (less than 24 V) applied to the flat part of the lead. Contact time must be limited to 10 seconds at up to 300 °C. When using a dedicated tool, all other leads can be soldered in one operation within 2 to 5 seconds between 270 and 320 °C.

---

**Sound fader control circuit**
**TEA6300**  
**TEA6300T**

---

**DEFINITIONS**

<b>Data sheet status</b>	
Objective specification	This data sheet contains target or goal specifications for product development.
Preliminary specification	This data sheet contains preliminary data; supplementary data may be published later.
Product specification	This data sheet contains final product specifications.
<b>Limiting values</b>	
Limiting values given are in accordance with the Absolute Maximum Rating System (IEC 134). Stress above one or more of the limiting values may cause permanent damage to the device. These are stress ratings only and operation of the device at these or at any other conditions above those given in the Characteristics sections of the specification is not implied. Exposure to limiting values for extended periods may affect device reliability.	
<b>Application information</b>	
Where application information is given, it is advisory and does not form part of the specification.	

**LIFE SUPPORT APPLICATIONS**

These products are not designed for use in life support appliances, devices, or systems where malfunction of these products can reasonably be expected to result in personal injury. Philips customers using or selling these products for use in such applications do so at their own risk and agree to fully indemnify Philips for any damages resulting from such improper use or sale.