

SN54HC193, SN74HC193 4-BIT SYNCHRONOUS UP/DOWN COUNTERS (DUAL CLOCK WITH CLEAR)

SCLS122D – DECEMBER 1982 – REVISED OCTOBER 2003

- Wide Operating Voltage Range of 2 V to 6 V
- Outputs Can Drive Up To 10 LSTTL Loads
- Low Power Consumption, 80- μ A Max I_{CC}
- Typical $t_{pd} = 20$ ns
- ± 4 -mA Output Drive at 5 V
- Low Input Current of 1 μ A Max
- Look-Ahead Circuitry Enhances Cascaded Counters
- Fully Synchronous in Count Modes
- Parallel Asynchronous Load for Modulo-N Count Lengths
- Asynchronous Clear

SN54HC193 . . . J OR W PACKAGE
SN74HC193 . . . D, N, NS, OR PW PACKAGE
(TOP VIEW)

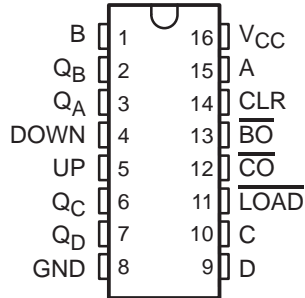

SN54HC193 . . . FK PACKAGE
(TOP VIEW)

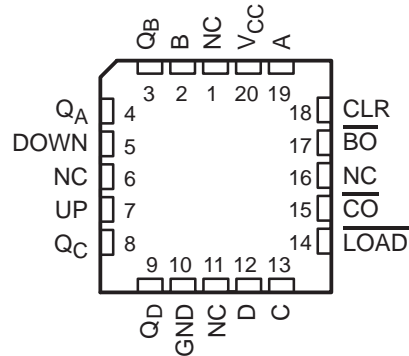

NC – No internal connection

description/ordering information

The 'HC193 devices are 4-bit synchronous, reversible, up/down binary counters. Synchronous operation is provided by having all flip-flops clocked simultaneously so that the outputs change coincidentally with each other when so instructed by the steering logic. This mode of operation eliminates the output counting spikes normally associated with asynchronous (ripple-clock) counters.

ORDERING INFORMATION

TA	PACKAGE†		ORDERABLE PART NUMBER	TOP-SIDE MARKING
-40°C to 85°C	PDIP – N	Tube of 25	SN74HC193N	SN74HC193N
	SOIC – D	Tube of 40	SN74HC193D	HC193
		Reel of 2500	SN74HC193DR	
		Reel of 250	SN74HC193DT	
	SOP – NS	Reel of 2000	SN74HC193NSR	HC193
	TSSOP – PW	Tube of 90	SN74HC193PW	HC193
Reel of 2000		SN74HC193PWR		
Reel of 250		SN74HC193PWT		
-55°C to 125°C	CDIP – J	Tube of 25	SNJ54HC193J	SNJ54HC193J
	CFP – W	Tube of 150	SNJ54HC193W	SNJ54HC193W
	LCCC – FK	Tube of 55	SNJ54HC193FK	SNJ54HC193FK

† Package drawings, standard packing quantities, thermal data, symbolization, and PCB design guidelines are available at www.ti.com/sc/package.



Please be aware that an important notice concerning availability, standard warranty, and use in critical applications of Texas Instruments semiconductor products and disclaimers thereto appears at the end of this data sheet.

PRODUCTION DATA information is current as of publication date. Products conform to specifications per the terms of Texas Instruments standard warranty. Production processing does not necessarily include testing of all parameters.

 **TEXAS
INSTRUMENTS**

POST OFFICE BOX 655303 • DALLAS, TEXAS 75265

Copyright © 2003, Texas Instruments Incorporated
On products compliant to MIL-PRF-38535, all parameters are tested unless otherwise noted. On all other products, production processing does not necessarily include testing of all parameters.

SN54HC193, SN74HC193 4-BIT SYNCHRONOUS UP/DOWN COUNTERS (DUAL CLOCK WITH CLEAR)

SCLS122D – DECEMBER 1982 – REVISED OCTOBER 2003

description/ordering information (continued)

The outputs of the four flip-flops are triggered on a low-to-high-level transition of either count (clock) input (UP or DOWN). The direction of counting is determined by which count input is pulsed while the other count input is high.

All four counters are fully programmable; that is, each output may be preset to either level by placing a low on the load ($\overline{\text{LOAD}}$) input and entering the desired data at the data inputs. The output changes to agree with the data inputs independently of the count pulses. This feature allows the counters to be used as modulo-N dividers simply by modifying the count length with the preset inputs.

A clear (CLR) input has been provided that forces all outputs to the low level when a high level is applied. The clear function is independent of the count and $\overline{\text{LOAD}}$ inputs.

These counters were designed to be cascaded without the need for external circuitry. The borrow ($\overline{\text{BO}}$) output produces a low-level pulse while the count is zero (all outputs low) and DOWN is low. Similarly, the carry ($\overline{\text{CO}}$) output produces a low-level pulse while the count is maximum (9 or 15), and UP is low. The counters then can be cascaded easily by feeding $\overline{\text{BO}}$ and $\overline{\text{CO}}$ to DOWN and UP, respectively, of the succeeding counter.



POST OFFICE BOX 655303 • DALLAS, TEXAS 75265

SN54HC193, SN74HC193 4-BIT SYNCHRONOUS UP/DOWN COUNTERS (DUAL CLOCK WITH CLEAR)

SCLS122D – DECEMBER 1982 – REVISED OCTOBER 2003

logic diagram (positive logic)

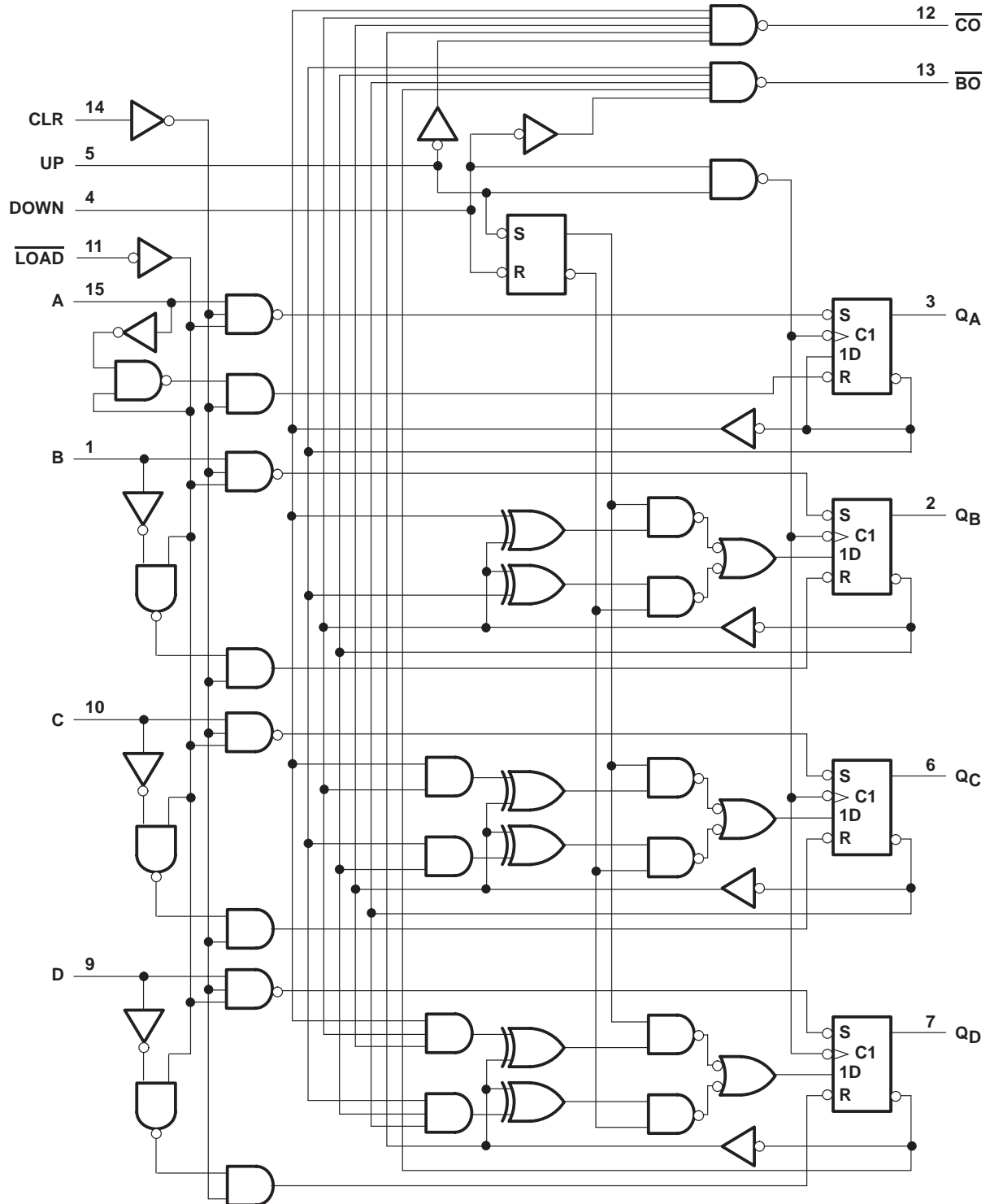

Pin numbers shown are for the D, J, N, NS, PW, and W packages.

SN54HC193, SN74HC193 4-BIT SYNCHRONOUS UP/DOWN COUNTERS (DUAL CLOCK WITH CLEAR)

SCLS122D – DECEMBER 1982 – REVISED OCTOBER 2003

typical clear, load, and count sequence

The following sequence is illustrated below:

1. Clear outputs to 0
2. Load (preset) to binary 13
3. Count up to 14, 15, carry, 0, 1, and 2
4. Count down to 1, 0, borrow, 15, 14, and 13

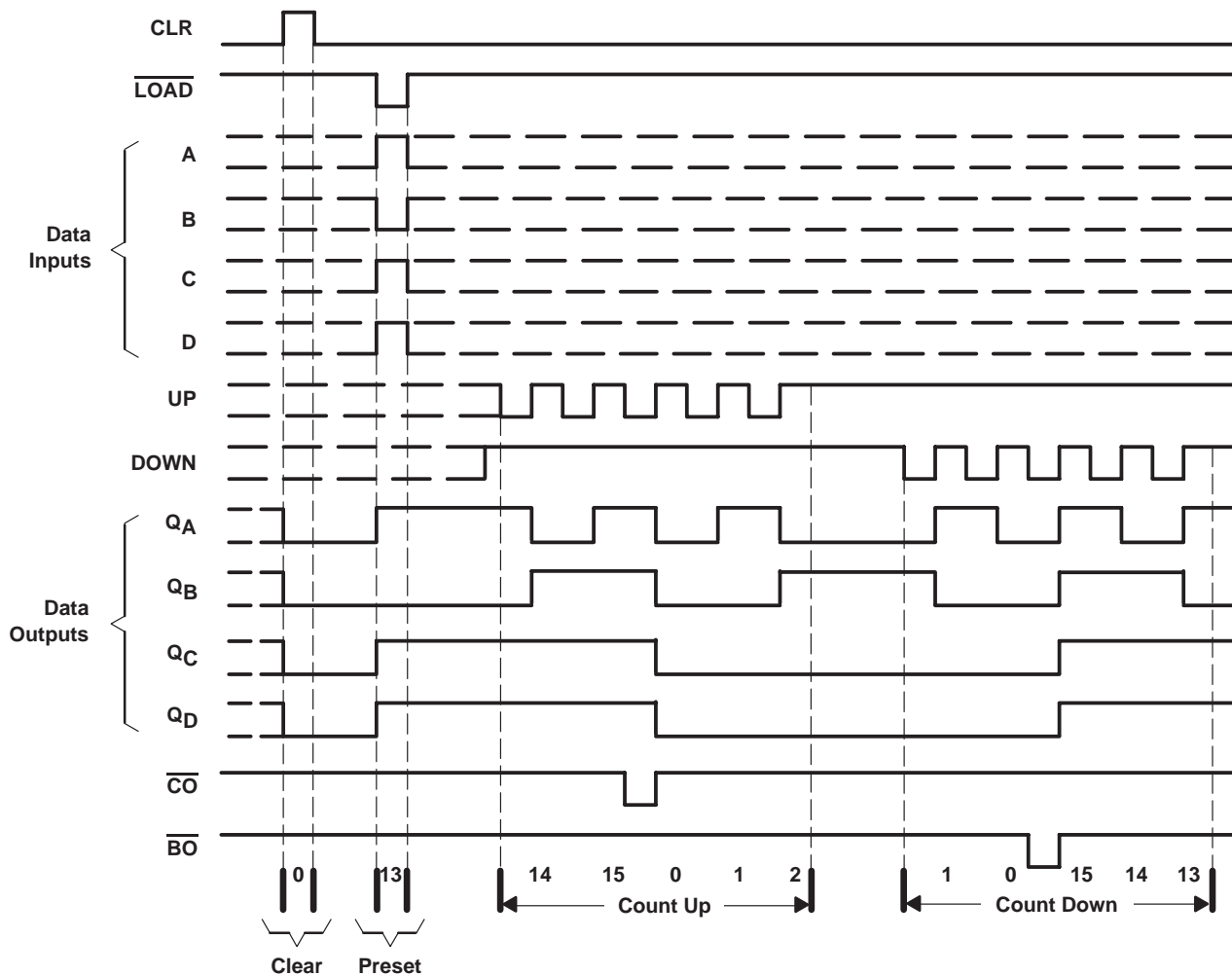

NOTES: A. CLR overrides $\overline{\text{LOAD}}$, data, and count inputs.

B. When counting up, count-down input must be high; when counting down, count-up input must be high.



POST OFFICE BOX 655303 • DALLAS, TEXAS 75265

SN54HC193, SN74HC193 4-BIT SYNCHRONOUS UP/DOWN COUNTERS (DUAL CLOCK WITH CLEAR)

SCLS122D – DECEMBER 1982 – REVISED OCTOBER 2003

absolute maximum ratings over operating free-air temperature range (unless otherwise noted)†

Supply voltage range, V_{CC}	–0.5 V to 7 V
Input clamp current, I_{IK} ($V_I < 0$ or $V_I > V_{CC}$) (see Note 1)	±20 mA
Output clamp current, I_{OK} ($V_O < 0$ or $V_O > V_{CC}$) (see Note 1)	±20 mA
Continuous output current, I_O ($V_O = 0$ to V_{CC})	±25 mA
Continuous current through V_{CC} or GND	±50 mA
Package thermal impedance, θ_{JA} (see Note 2): D package	73°C/W
N package	67°C/W
NS package	64°C/W
PW package	108°C/W
Storage temperature range, T_{stg}	–65°C to 150°C

† Stresses beyond those listed under “absolute maximum ratings” may cause permanent damage to the device. These are stress ratings only, and functional operation of the device at these or any other conditions beyond those indicated under “recommended operating conditions” is not implied. Exposure to absolute-maximum-rated conditions for extended periods may affect device reliability.

- NOTES: 1. The input and output voltage ratings may be exceeded if the input and output current ratings are observed.
2. The package thermal impedance is calculated in accordance with JESD 51-7.

recommended operating conditions (see Note 3)

		SN54HC193			SN74HC193			UNIT
		MIN	NOM	MAX	MIN	NOM	MAX	
V_{CC}	Supply voltage	2	5	6	2	5	6	V
V_{IH}	High-level input voltage	$V_{CC} = 2$ V		1.5	$V_{CC} = 2$ V		1.5	V
		$V_{CC} = 4.5$ V		3.15	$V_{CC} = 4.5$ V		3.15	
		$V_{CC} = 6$ V		4.2	$V_{CC} = 6$ V		4.2	
V_{IL}	Low-level input voltage	$V_{CC} = 2$ V			$V_{CC} = 2$ V		0.5	V
		$V_{CC} = 4.5$ V			$V_{CC} = 4.5$ V		1.35	
		$V_{CC} = 6$ V			$V_{CC} = 6$ V		1.8	
V_I	Input voltage	0		V_{CC}	0		V_{CC}	V
V_O	Output voltage	0		V_{CC}	0		V_{CC}	V
$\Delta t/\Delta v$ ‡	Input transition rise/fall time	$V_{CC} = 2$ V			$V_{CC} = 2$ V		1000	ns
		$V_{CC} = 4.5$ V			$V_{CC} = 4.5$ V		500	
		$V_{CC} = 6$ V			$V_{CC} = 6$ V		400	
T_A	Operating free-air temperature	–55		125	–40		85	°C

NOTE 3: All unused inputs of the device must be held at V_{CC} or GND to ensure proper device operation. Refer to the TI application report, *Implications of Slow or Floating CMOS Inputs*, literature number SCBA004.

‡ If this device is used in the threshold region (from $V_{ILmax} = 0.5$ V to $V_{IHmin} = 1.5$ V), there is a potential to go into the wrong state from induced grounding, causing double clocking. Operating with the inputs at $t_f = 1000$ ns and $V_{CC} = 2$ V does not damage the device; however, functionally, the CLK inputs are not ensured while in the shift, count, or toggle operating modes.



SN54HC193, SN74HC193

4-BIT SYNCHRONOUS UP/DOWN COUNTERS

(DUAL CLOCK WITH CLEAR)

SCLS122D – DECEMBER 1982 – REVISED OCTOBER 2003

electrical characteristics over recommended operating free-air temperature range (unless otherwise noted)

PARAMETER	TEST CONDITIONS		V _{CC}	T _A = 25°C			SN54HC193		SN74HC193		UNIT
				MIN	TYP	MAX	MIN	MAX	MIN	MAX	
V _{OH}	V _I = V _{IH} or V _{IL}	I _{OH} = -20 μA	2 V	1.9	1.998		1.9		1.9	V	
			4.5 V	4.4	4.499		4.4		4.4		
			6 V	5.9	5.999		5.9		5.9		
		I _{OH} = -4 mA	4.5 V	3.98	4.3		3.7		3.84		
			6 V	5.48	5.8		5.2		5.34		
V _{OL}	V _I = V _{IH} or V _{IL}	I _{OL} = 20 μA	2 V		0.002	0.1		0.1		V	
			4.5 V		0.001	0.1		0.1			0.1
			6 V		0.001	0.1		0.1			0.1
		I _{OL} = 4 mA	4.5 V		0.17	0.26		0.4			0.33
			6 V		0.15	0.26		0.4			0.33
I _I	V _I = V _{CC} or 0		6 V		±0.1	±100		±1000		±1000	nA
I _{CC}	V _I = V _{CC} or 0, I _O = 0		6 V			8		160		80	μA
C _i			2 V to 6 V		3	10		10		10	pF

timing requirements over recommended operating free-air temperature range (unless otherwise noted)

		V _{CC}	T _A = 25°C		SN54HC193		SN74HC193		UNIT
			MIN	MAX	MIN	MAX	MIN	MAX	
f _{clock}	Clock frequency	2 V		4.2		2.8		3.3	MHz
		4.5 V		21		14		17	
		6 V		24		16		19	
t _w	CLR high	2 V		120		180		150	ns
		4.5 V		24		36		30	
		6 V		21		31		26	
	LOAD low	2 V		120		180		150	
		4.5 V		24		36		30	
		6 V		21		31		26	
	UP or DOWN high or low	2 V		120		180		150	
		4.5 V		24		36		30	
		6 V		21		31		26	
t _{su}	Data before LOAD inactive	2 V		110		165		140	ns
		4.5 V		22		33		28	
		6 V		19		28		24	
	CLR inactive before UP↑ or DOWN↑	2 V		110		165		140	
		4.5 V		22		33		28	
		6 V		19		28		24	
	LOAD inactive before UP↑ or DOWN↑	2 V		110		165		140	
		4.5 V		22		33		28	
		6 V		19		28		24	
t _h	Data after LOAD inactive	2 V		5		5		5	ns
		4.5 V		5		5		5	
		6 V		5		5		5	



SN54HC193, SN74HC193
4-BIT SYNCHRONOUS UP/DOWN COUNTERS
(DUAL CLOCK WITH CLEAR)

SCLS122D – DECEMBER 1982 – REVISED OCTOBER 2003

switching characteristics over recommended operating free-air temperature range, $C_L = 50$ pF (unless otherwise noted) (see Figure 1)

PARAMETER	FROM (INPUT)	TO (OUTPUT)	V _{CC}	T _A = 25°C			SN54HC193		SN74HC193		UNIT
				MIN	TYP	MAX	MIN	MAX	MIN	MAX	
f _{max}			2 V	4.2	8		2.8		3.3	MHz	
			4.5 V	21	55		14		17		
			6 V	24	60		16		19		
t _{pd}	UP	\overline{CO}	2 V		75	165		250		205	ns
			4.5 V		24	33		50		41	
			6 V		20	28		43		35	
	DOWN	\overline{BO}	2 V		75	165		250		205	
			4.5 V		24	33		50		41	
			6 V		20	28		43		35	
	UP or DOWN	Any Q	2 V		190	250		375		315	
			4.5 V		40	50		75		63	
			6 V		35	43		64		54	
	\overline{LOAD}	Any Q	2 V		190	260		390		325	
			4.5 V		40	52		78		65	
			6 V		35	44		66		55	
t _{PHL}	CLR	Any Q	2 V		170	240		360		300	ns
			4.5 V		36	48		72		60	
			6 V		31	41		61		51	
t _t		Any	2 V		38	75		110		95	ns
			4.5 V		8	15		22		19	
			6 V		6	13		19		16	

operating characteristics, T_A = 25°C

PARAMETER	TEST CONDITIONS	TYP	UNIT
C _{pd} Power dissipation capacitance	No load	50	pF

SN54HC193, SN74HC193 4-BIT SYNCHRONOUS UP/DOWN COUNTERS (DUAL CLOCK WITH CLEAR)

SCLS122D – DECEMBER 1982 – REVISED OCTOBER 2003

PARAMETER MEASUREMENT INFORMATION

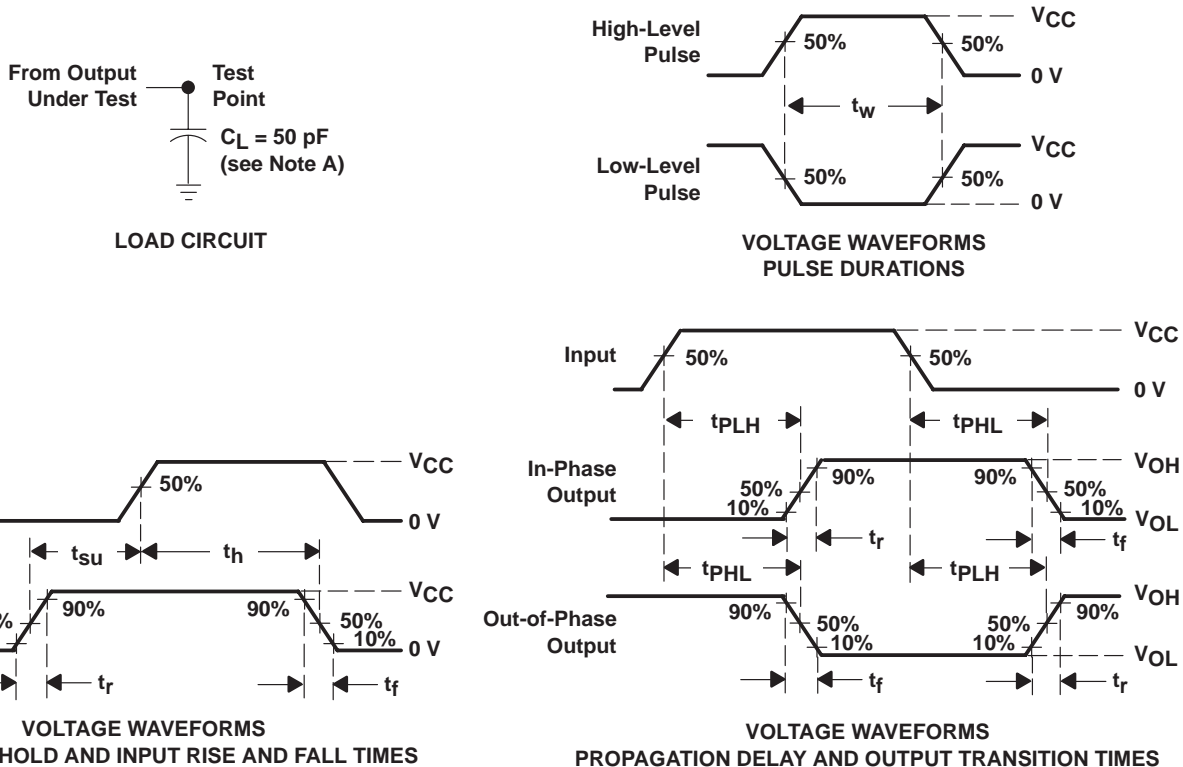

- NOTES:
- A. C_L includes probe and test-fixture capacitance.
 - B. Phase relationships between waveforms were chosen arbitrarily. All input pulses are supplied by generators having the following characteristics: $PRR \leq 1 \text{ MHz}$, $Z_O = 50 \Omega$, $t_r = 6 \text{ ns}$, $t_f = 6 \text{ ns}$.
 - C. For clock inputs, f_{max} is measured when the input duty cycle is 50%.
 - D. The outputs are measured one at a time with one input transition per measurement.
 - E. t_{PLH} and t_{PHL} are the same as t_{pd} .

Figure 1. Load Circuit and Voltage Waveforms

J (R-GDIP-T**)

14 LEADS SHOWN

CERAMIC DUAL IN-LINE PACKAGE



DIM \ PINS **	14	16	18	20
A	0.300 (7,62) BSC	0.300 (7,62) BSC	0.300 (7,62) BSC	0.300 (7,62) BSC
B MAX	0.785 (19,94)	.840 (21,34)	0.960 (24,38)	1.060 (26,92)
B MIN	—	—	—	—
C MAX	0.300 (7,62)	0.300 (7,62)	0.310 (7,87)	0.300 (7,62)
C MIN	0.245 (6,22)	0.245 (6,22)	0.220 (5,59)	0.245 (6,22)



4040083/F 03/03

- NOTES:
- A. All linear dimensions are in inches (millimeters).
 - B. This drawing is subject to change without notice.
 - C. This package is hermetically sealed with a ceramic lid using glass frit.
 - D. Index point is provided on cap for terminal identification only on press ceramic glass frit seal only.
 - E. Falls within MIL STD 1835 GDIP1-T14, GDIP1-T16, GDIP1-T18 and GDIP1-T20.

FK (S-CQCC-N**)

LEADLESS CERAMIC CHIP CARRIER

28 TERMINAL SHOWN



- NOTES:
- A. All linear dimensions are in inches (millimeters).
 - B. This drawing is subject to change without notice.
 - C. This package can be hermetically sealed with a metal lid.
 - D. The terminals are gold plated.
 - E. Falls within JEDEC MS-004

N (R-PDIP-T**)

PLASTIC DUAL-IN-LINE PACKAGE

16 PINS SHOWN

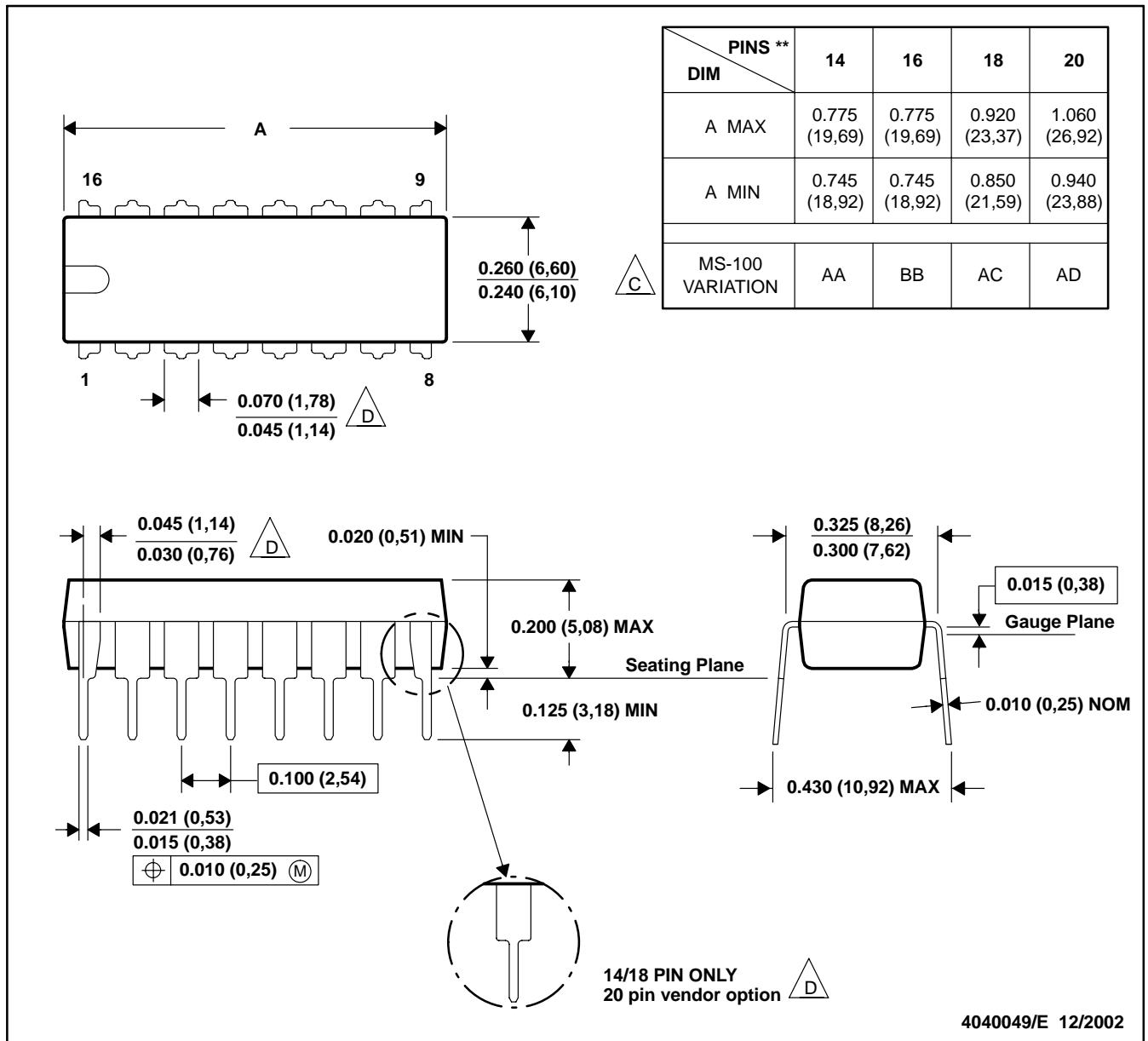

- NOTES: A. All linear dimensions are in inches (millimeters).
 B. This drawing is subject to change without notice.
 (C) Falls within JEDEC MS-001, except 18 and 20 pin minimum body length (Dim A).
 (D) The 20 pin end lead shoulder width is a vendor option, either half or full width.

D (R-PDSO-G**)

PLASTIC SMALL-OUTLINE PACKAGE

8 PINS SHOWN

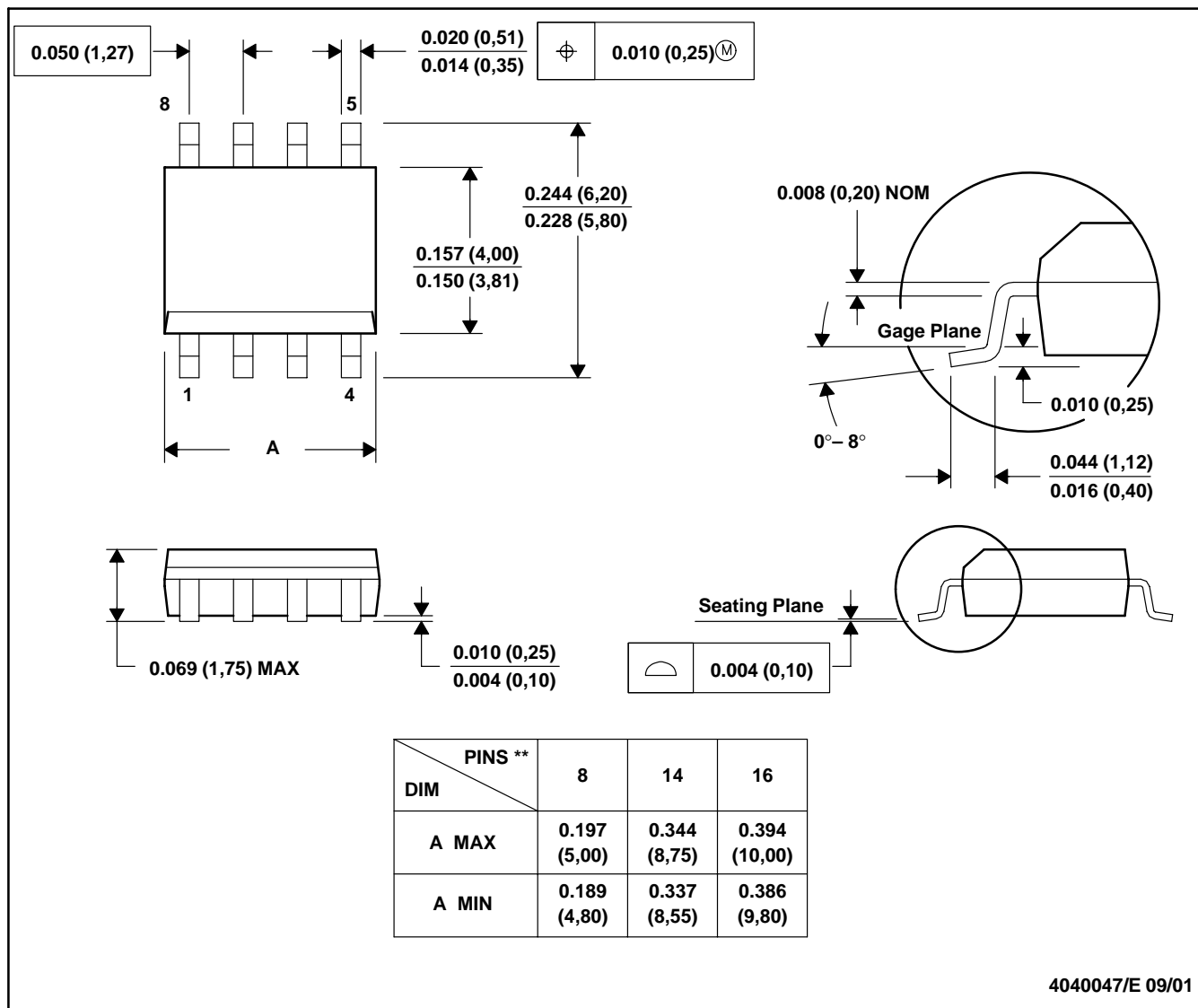

4040047/E 09/01

- NOTES: A. All linear dimensions are in inches (millimeters).
 B. This drawing is subject to change without notice.
 C. Body dimensions do not include mold flash or protrusion, not to exceed 0.006 (0,15).
 D. Falls within JEDEC MS-012

MECHANICAL DATA

NS (R-PDSO-G**)

PLASTIC SMALL-OUTLINE PACKAGE

14-PINS SHOWN



- NOTES:
- A. All linear dimensions are in millimeters.
 - B. This drawing is subject to change without notice.
 - C. Body dimensions do not include mold flash or protrusion, not to exceed 0,15.

PW (R-PDSO-G**)

PLASTIC SMALL-OUTLINE PACKAGE

14 PINS SHOWN



4040064/F 01/97

- NOTES: A. All linear dimensions are in millimeters.
 B. This drawing is subject to change without notice.
 C. Body dimensions do not include mold flash or protrusion not to exceed 0,15.
 D. Falls within JEDEC MO-153

IMPORTANT NOTICE

Texas Instruments Incorporated and its subsidiaries (TI) reserve the right to make corrections, modifications, enhancements, improvements, and other changes to its products and services at any time and to discontinue any product or service without notice. Customers should obtain the latest relevant information before placing orders and should verify that such information is current and complete. All products are sold subject to TI's terms and conditions of sale supplied at the time of order acknowledgment.

TI warrants performance of its hardware products to the specifications applicable at the time of sale in accordance with TI's standard warranty. Testing and other quality control techniques are used to the extent TI deems necessary to support this warranty. Except where mandated by government requirements, testing of all parameters of each product is not necessarily performed.

TI assumes no liability for applications assistance or customer product design. Customers are responsible for their products and applications using TI components. To minimize the risks associated with customer products and applications, customers should provide adequate design and operating safeguards.

TI does not warrant or represent that any license, either express or implied, is granted under any TI patent right, copyright, mask work right, or other TI intellectual property right relating to any combination, machine, or process in which TI products or services are used. Information published by TI regarding third-party products or services does not constitute a license from TI to use such products or services or a warranty or endorsement thereof. Use of such information may require a license from a third party under the patents or other intellectual property of the third party, or a license from TI under the patents or other intellectual property of TI.

Reproduction of information in TI data books or data sheets is permissible only if reproduction is without alteration and is accompanied by all associated warranties, conditions, limitations, and notices. Reproduction of this information with alteration is an unfair and deceptive business practice. TI is not responsible or liable for such altered documentation.

Resale of TI products or services with statements different from or beyond the parameters stated by TI for that product or service voids all express and any implied warranties for the associated TI product or service and is an unfair and deceptive business practice. TI is not responsible or liable for any such statements.

Following are URLs where you can obtain information on other Texas Instruments products and application solutions:

Products		Applications	
Amplifiers	amplifier.ti.com	Audio	www.ti.com/audio
Data Converters	dataconverter.ti.com	Automotive	www.ti.com/automotive
DSP	dsp.ti.com	Broadband	www.ti.com/broadband
Interface	interface.ti.com	Digital Control	www.ti.com/digitalcontrol
Logic	logic.ti.com	Military	www.ti.com/military
Power Mgmt	power.ti.com	Optical Networking	www.ti.com/opticalnetwork
Microcontrollers	microcontroller.ti.com	Security	www.ti.com/security
		Telephony	www.ti.com/telephony
		Video & Imaging	www.ti.com/video
		Wireless	www.ti.com/wireless

Mailing Address: Texas Instruments
Post Office Box 655303 Dallas, Texas 75265

Copyright © 2003, Texas Instruments Incorporated