

A6800/A6801

DABiC-5 Latched Sink Drivers

A6800SA

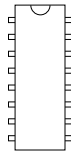

A6800SL



A6801SA

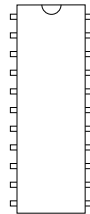

A6801SEP

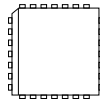

A6801SLW

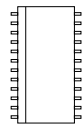

ABSOLUTE MAXIMUM RATINGS

Output Voltage, V_{CE}	50 V
Supply Voltage, V_{DD}	7 V
Input Voltage Range, V_{IN}	-0.3 V to $V_{DD}+0.3 V$
Continuous Collector Current, I_C	600 mA
Package Power Dissipation, P_D , see Allowable Power Dissipation chart, page 5	
Operating Temperature Range	
Ambient Temperature, T_A	-20°C to +85°C
Storage Temperature, T_S	-55°C to +150°C

Caution: CMOS devices have input-static protection, but are susceptible to damage when exposed to extremely high static-electrical charges.

The A6800 and A6801 latched-input BiMOS ICs merge high-current, high-voltage outputs with CMOS logic. The CMOS input section consists of 4 or 8 data ('D' type) latches with associated common CLEAR, STROBE, and OUTPUT ENABLE circuitry. The power outputs are bipolar NPN Darlington. This merged technology provides versatile, flexible interface. These BiMOS power interface ICs greatly benefit the simplification of computer or microprocessor I/O. The A6800 ICs each contain four latched drivers. A6801 ICs contain eight latched drivers.

The CMOS inputs are compatible with standard CMOS circuits. TTL circuits may mandate the addition of input pull-up resistors. The bipolar Darlington outputs are suitable for directly driving many peripheral/power loads: relays, lamps, solenoids, small dc motors, etc.

All devices have open-collector outputs and integral diodes for inductive load transient suppression. The output transistors are capable of sinking 600 mA and will withstand at least 50 V in the OFF state. Because of limitations on package power dissipation, the simultaneous operation of all drivers at maximum rated current can only be accomplished by a reduction in duty cycle. Outputs may be paralleled for higher load current capability.

The A6800SA is furnished in a standard 14-pin DIP; the A6800SL and A6801SLW in surface-mountable SOICs; the A6801SA in a 22-pin DIP with 0.400" (10.16 mm) row centers; the A6801SEP in a 28-lead PLCC. These devices are lead (Pb) free, with 100% matte tin plated leadframes.

FEATURES

- 3.3 V to 5 V logic supply range
- To 10 MHz data input rate
- High-voltage, high-current outputs
- Darlington current-sink outputs, with improved low-saturation voltages
- CMOS, TTL compatible inputs
- Output transient protection
- Internal pull-down resistors
- Low-power CMOS latches

APPLICATIONS

- Relays
- Lamps
- Solenoids
- Small dc motors



Use the following complete part numbers when ordering:

Part Number	Pins	Package
A6800SA-T	14	DIP
A6800SL-T	14	SOIC
A6801SA-T	22	DIP
A6801SEP-T	28	PLCC
A6801SLW-T	24	SOIC

A6800/A6801 DABiC-5 Latched Sink Drivers

Datasheet
 26180.110

Functional Block Diagram

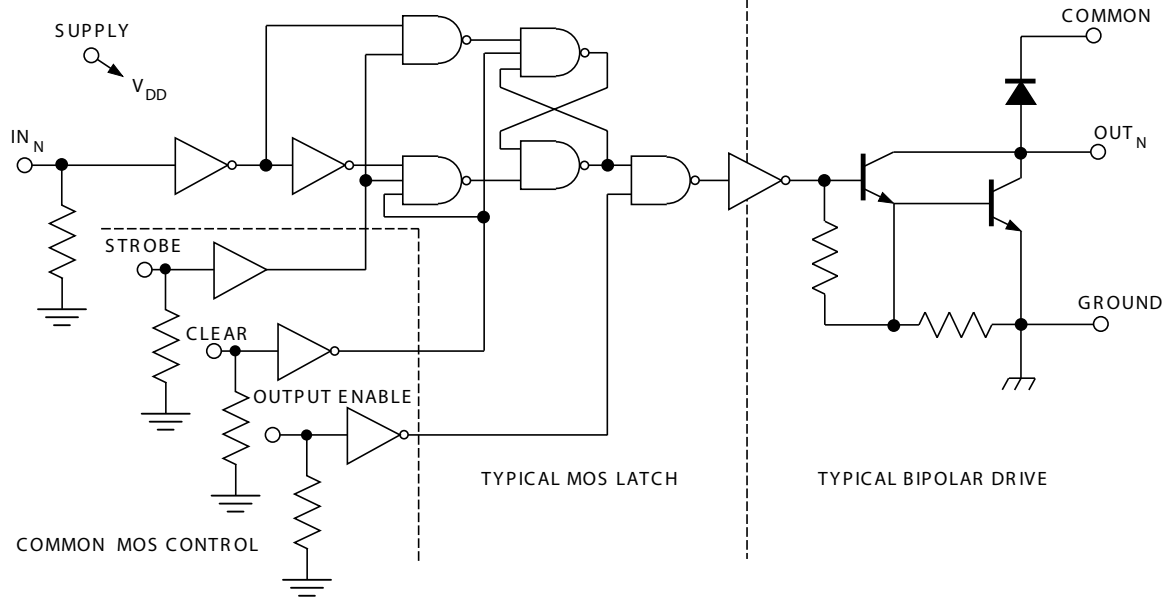

Typical Input Circuit

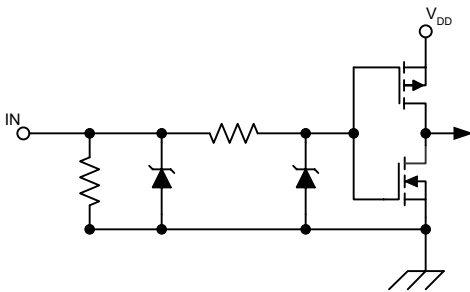

Allowable Power Dissipation

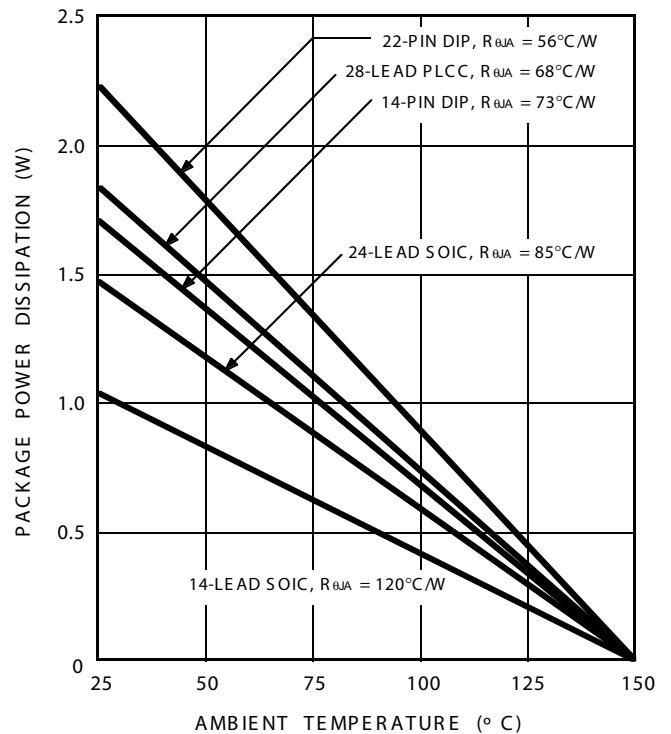

A6800/A6801

DABiC-5 Latched Sink Drivers

ELECTRICAL CHARACTERISTICS¹ Unless otherwise noted: $T_A = 25^\circ\text{C}$, logic supply operating voltage $V_{dd} = 3.0\text{V to } 5.5\text{V}$

Characteristic	Symbol	Test Conditions	$V_{dd} = 3.3\text{V}$			$V_{dd} = 5\text{V}$			Units
			Min.	Typ.	Max.	Min.	Typ.	Max.	
Output Leakage Current	I_{CEX}	$V_{OUT} = 50\text{V}$	–	–	10	–	–	10	μA
Output Sustaining Voltage	$V_{CE(SUS)}$	$I_{OUT} = 350\text{mA}$, $L = 3\text{mH}$	35	–	–	35	–	–	V
Collector-Emitter Saturation Voltage	$V_{CE(SAT)}$	$I_{OUT} = 100\text{mA}$	–	0.8	1.0	–	0.8	1.0	V
		$I_{OUT} = 200\text{mA}$	–	0.9	1.1	–	0.9	1.1	V
		$I_{OUT} = 350\text{mA}$ (See note 2)	–	1.0	1.3	–	1.0	1.3	V
Input Voltage	$V_{IN(1)}$		2.2	–	–	3.3	–	–	V
	$V_{IN(0)}$		–	–	1.1	–	–	1.7	V
Input Resistance	R_{IN}		50	–	–	50	–	–	$\text{k}\Omega$
Logic Supply Current	$I_{DD(1)}$	One output on, $I_{OUT} = 100\text{mA}$	–	–	1.0	–	–	1.0	mA
	$I_{DD(0)}$	All outputs off	–	130	150	–	130	150	μA
Clamp Diode Leakage Current	I_r	$V_r = 50\text{V}$	–	–	50	–	–	50	μA
Clamp Diode Forward Voltage	V_f	$I_f = 350\text{mA}$	–	–	2.0	–	–	2.0	V
Output Fall Time	t_f	$V_{CC} = 50\text{V}$, $R_1 = 500\Omega$, $C_1 \leq 30\text{pF}$	–	80	–	–	80	–	ns
Output Rise Time	t_r	$V_{CC} = 50\text{V}$, $R_1 = 500\Omega$, $C_1 \leq 30\text{pF}$	–	100	–	–	100	–	ns

¹ Operation of these devices with standard TTL or DTL may require the use of appropriate pull-up resistors to ensure a minimum logic 1.

² Because of limitations on package power dissipation, the simultaneous operation of multiple drivers can only be accomplished by reduction in duty cycle.

Truth Table

IN_N	STROBE	CLEAR	OUTPUT ENABLE	OUT_N	
				t-1	t
0	1	0	0	X	OFF
1	1	0	0	X	ON
X	X	1	X	X	OFF
X	X	X	1	X	OFF
X	0	0	0	ON	ON
X	0	0	0	OFF	OFF

X = irrelevant

t-1 = previous output state

t = present output state

A6800/A6801

DABiC-5 Latched Sink Drivers

Timing Requirements and Specifications

(Logic Levels are V_{DD} and Ground)

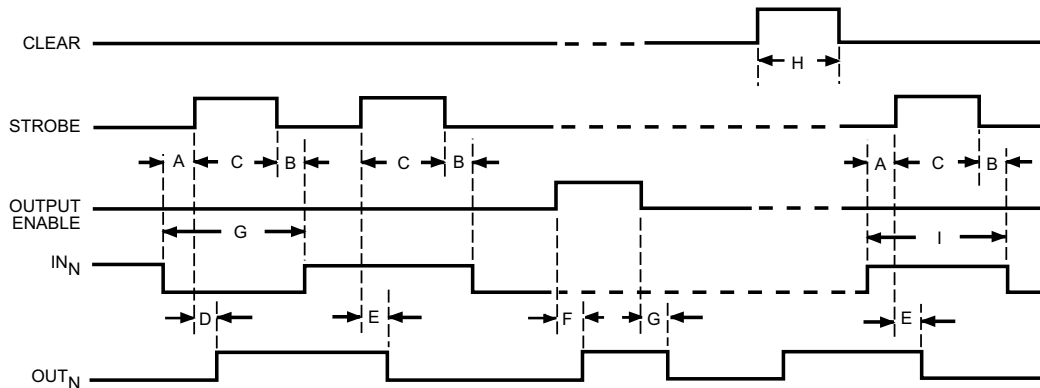

Key	Description	Time (ns)
A	Minimum data active time before Strobe enabled (Data Set-Up Time)	25
B	Minimum data active time after Strobe disabled (Data Hold Time)	25
C	Minimum Strobe pulse width	50
D	Maximum time between Strobe activation and transition from output on to output off*	500
E	Minimum time between Strobe activation and transition from output off to output on*	500
F	Maximum time between Output Enable activation and transition from output on to output off*	500
G	Minimum time between Output Enable activation and transition from output off to output on*	500
H	Minimum Clear pulse width	50
I	Minimum data pulse width	100

*Conditions for output transition testing are: $V_{DD} = 5.0\text{ V}$, $V_{CC} = 5\text{ V}$, $R1 = 500\ \Omega$, $C1 \leq 30\text{ pF}$.

NOTE: Information present at an input is transferred to its latch when the STROBE is high. A high CLEAR input will set all latches to the output off condition regardless of the data or STROBE input levels. A high

OUTPUT ENABLE will set all outputs to the off condition, regardless of any other input conditions. When the OUTPUT ENABLE is low, the outputs depend on the state of their respective latches.

A6800/A6801 DABiC-5 Latched Sink Drivers

Datasheet
 26180.110

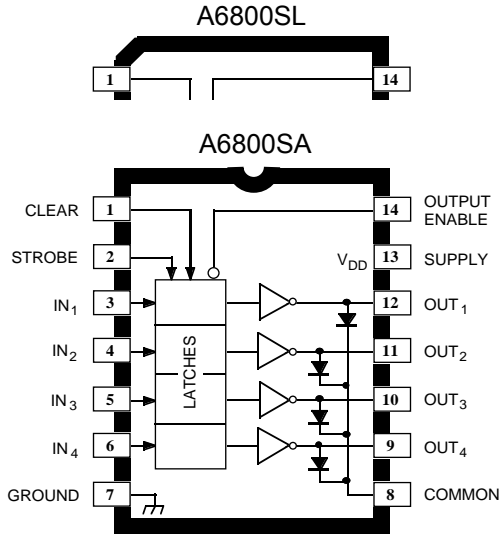

Dwg. PP-014A

Note: The A6800SL (SOIC) and the A6800SA (DIP) are electrically identical and share a common terminal number assignment.

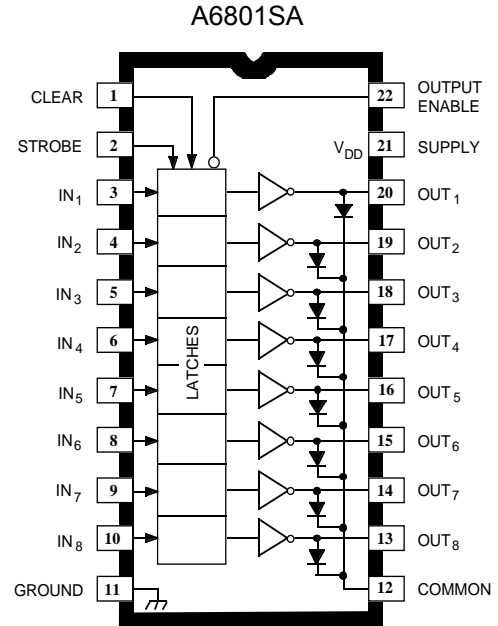

Dwg. PP-015

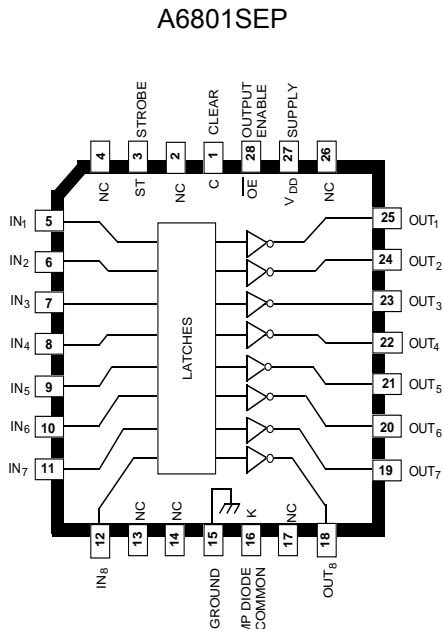

Dwg. PP-037

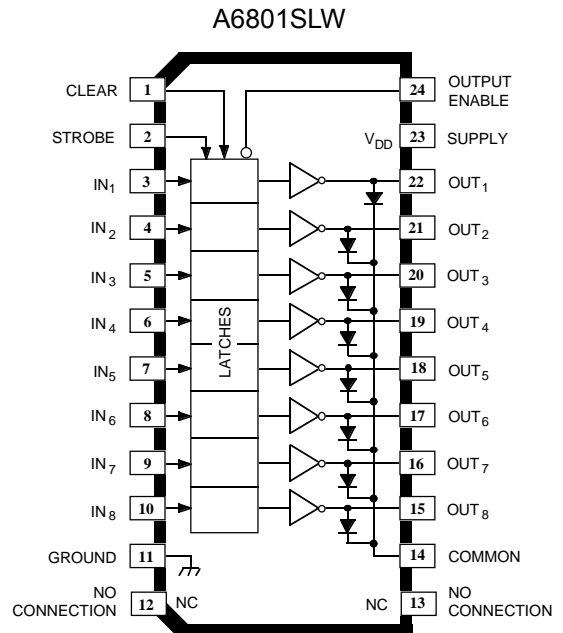

Dwg. PP-015-1

A6800/A6801 DABiC-5 Latched Sink Drivers

Datasheet
 26180.110

TYPICAL APPLICATION UNIPOLAR STEPPER-MOTOR DRIVE

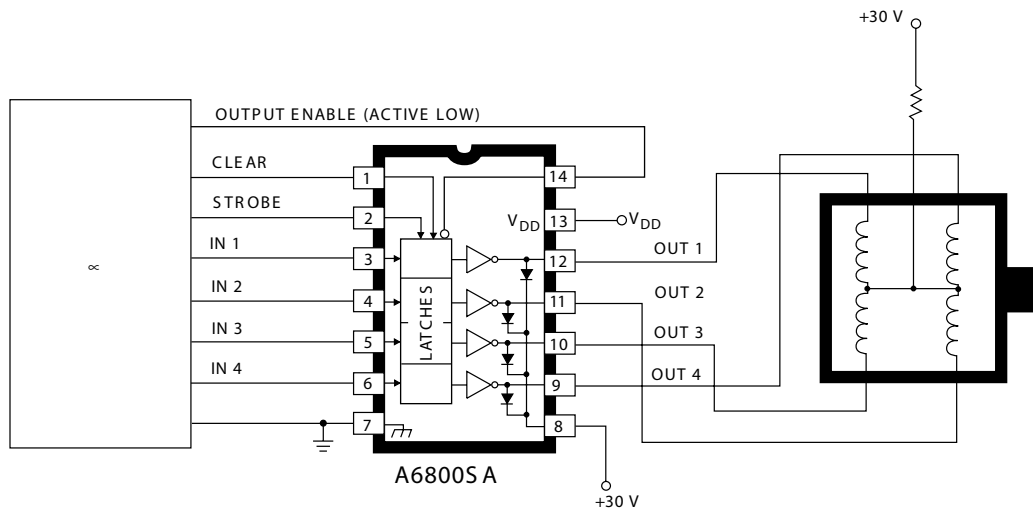

Dwg. No. B-1537

UNIPOLAR WAVE DRIVE

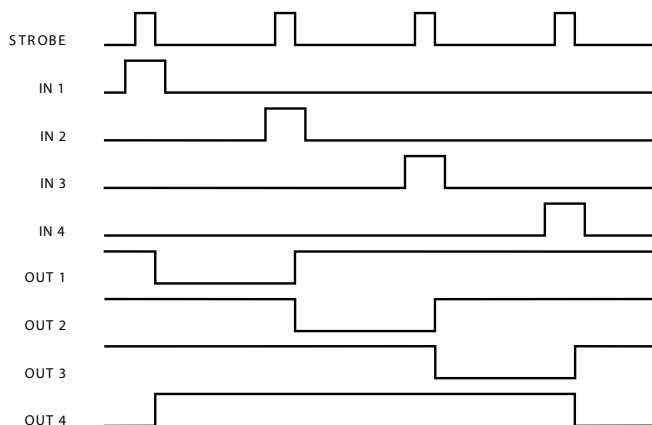

Dwg. GP-060

UNIPOLAR 2-PHASE DRIVE

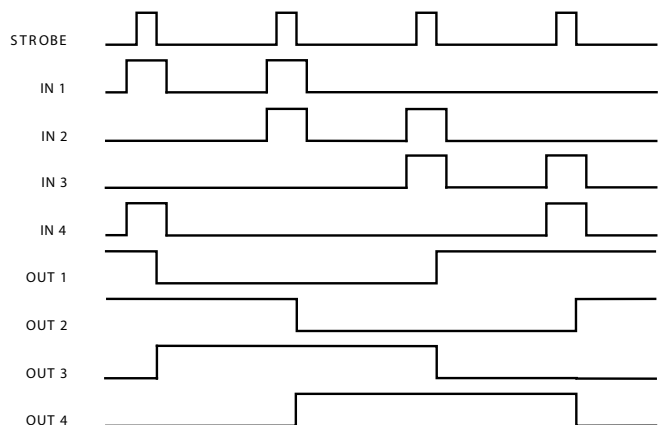

Dwg. GP-060-1

A6800/A6801 DABiC-5 Latched Sink Drivers

Datasheet
26180.110

A6800SA

Dimensions in Inches
(controlling dimensions)

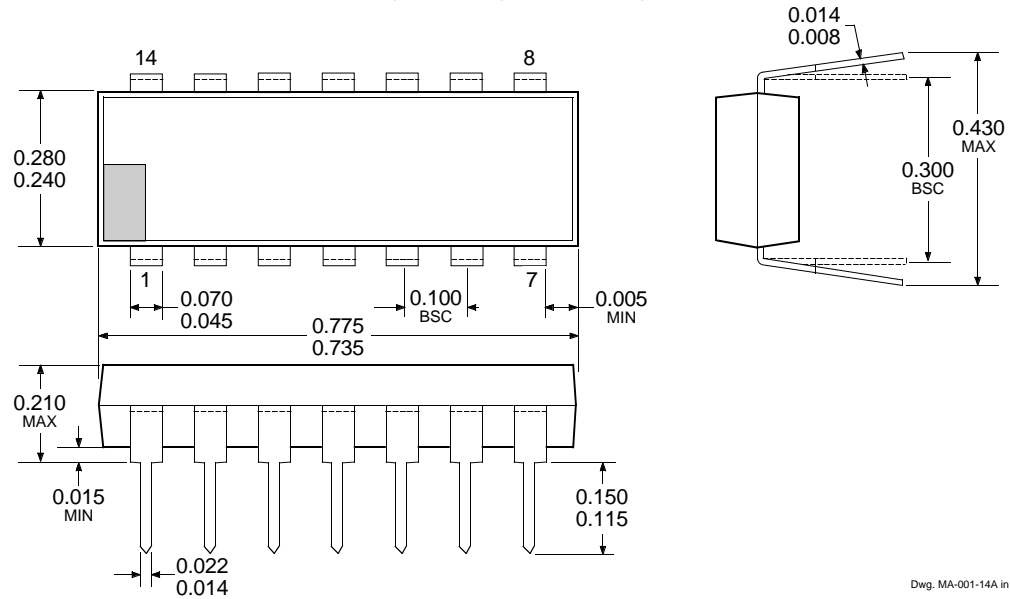

Dimensions in Millimeters
(for reference only)

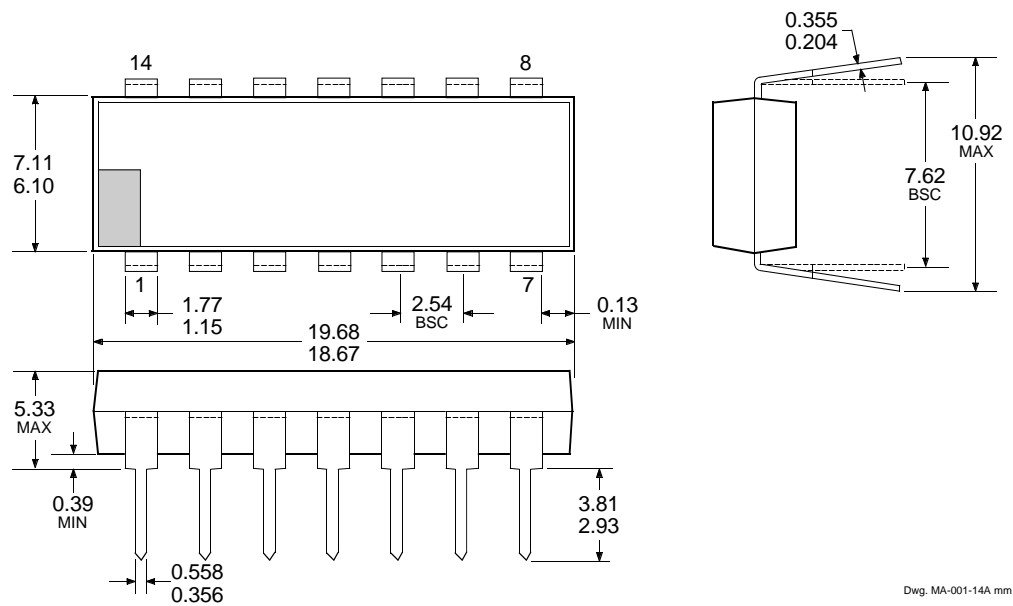

- NOTES: 1. Exact body and lead configuration at vendor's option within limits shown.
 2. Lead spacing tolerance is non-cumulative.
 3. Lead thickness is measured at seating plane or below.

A6800/A6801 DABiC-5 Latched Sink Drivers

Datasheet
26180.110

A6800SL

Dimensions in Inches
(for reference only)

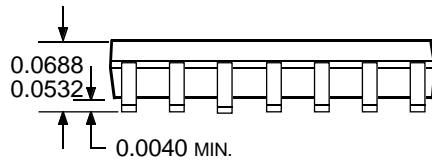
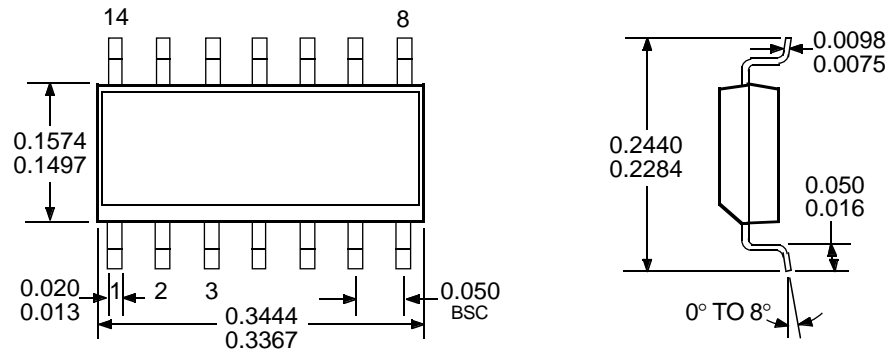

Dwg. MA-007-14 in

Dimensions in Millimeters
(controlling dimensions)

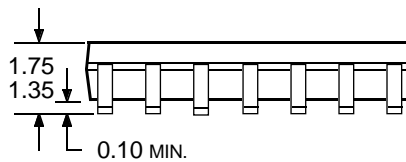
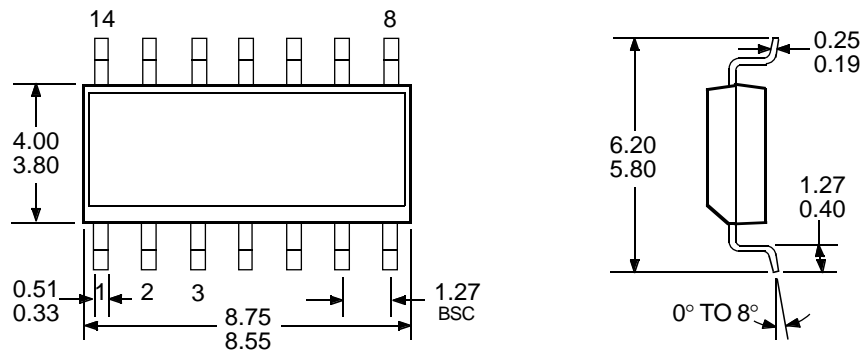

Dwg. MA-007-14A mm

- NOTES: 1. Exact body and lead configuration at vendor's option within limits shown.
2. Lead spacing tolerance is non-cumulative.

A6800/A6801 DABiC-5 Latched Sink Drivers

Datasheet
 26180.110

A6801SA

Dimensions in Inches
(controlling dimensions)

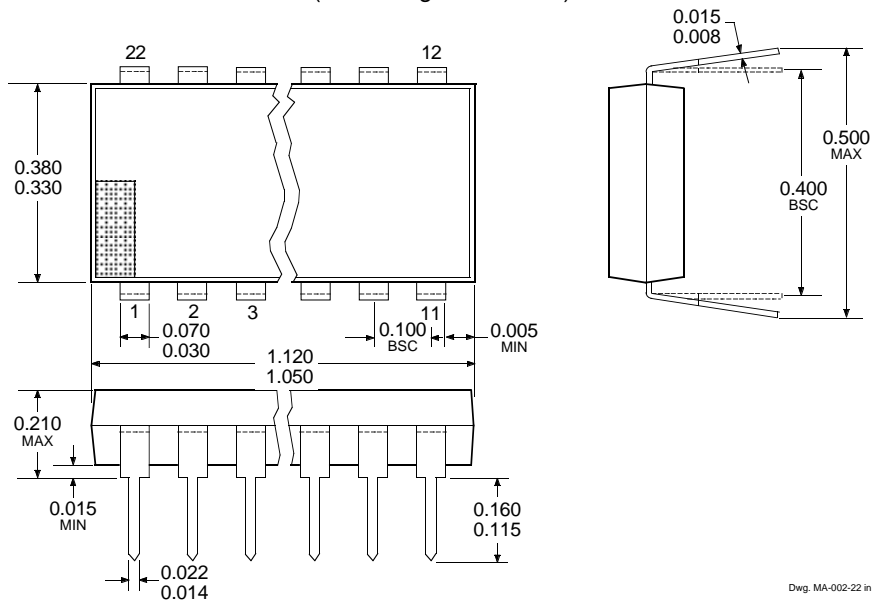

Dimensions in Millimeters
(for reference only)

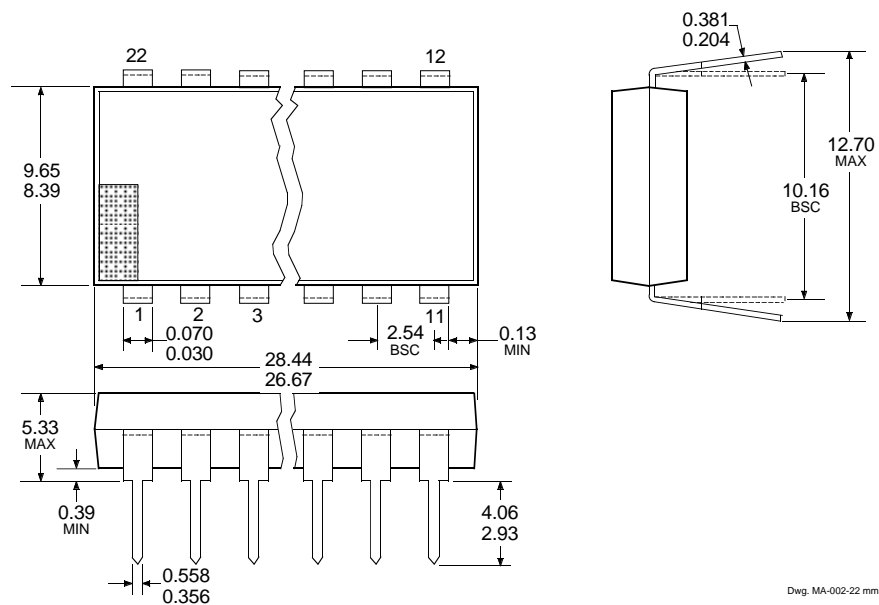

- NOTES:
1. Exact body and lead configuration at vendor's option within limits shown.
 2. Lead spacing tolerance is non-cumulative.
 3. Lead thickness is measured at seating plane or below.

A6800/A6801 DABiC-5 Latched Sink Drivers

Datasheet
26180.110

A6801SEP

Dimensions in Inches
(controlling dimensions)

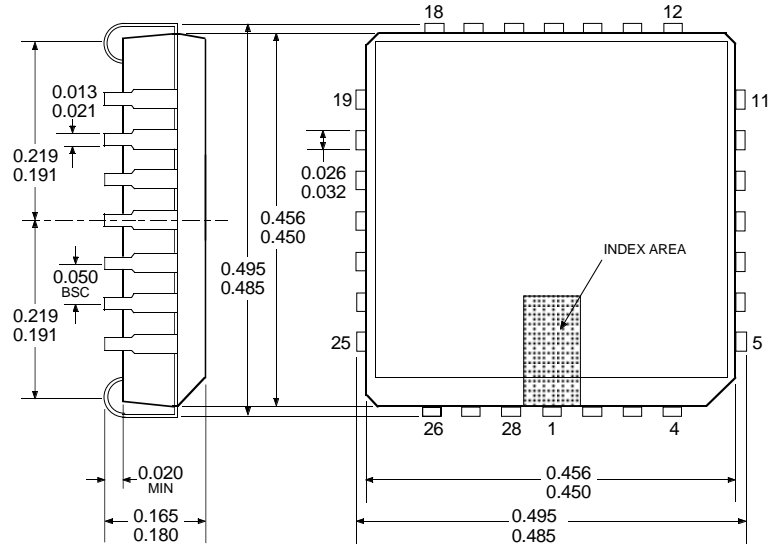

Dimensions in Millimeters
(for reference only)

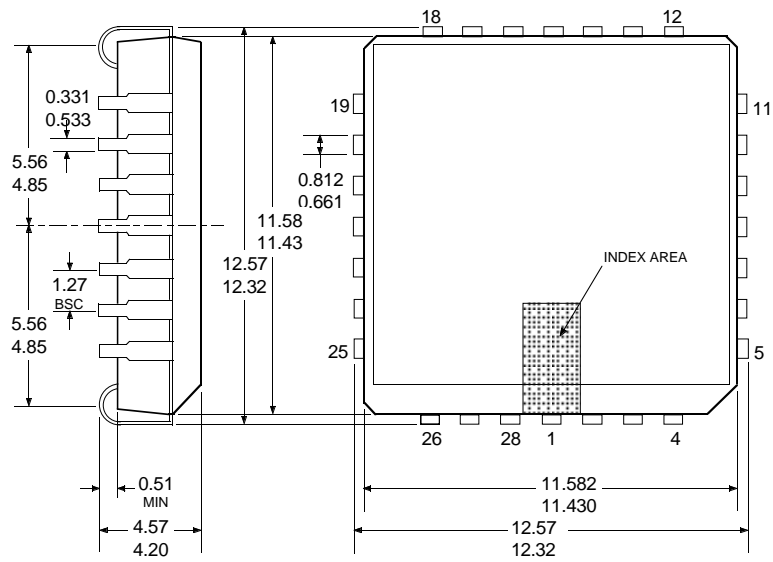

- NOTES: 1. Exact body and lead configuration at vendor's option within limits shown.
2. Lead spacing tolerance is non-cumulative.

A6800/A6801

DABiC-5 Latched Sink Drivers

A6801SLW

Dimensions in Inches
(for reference only)

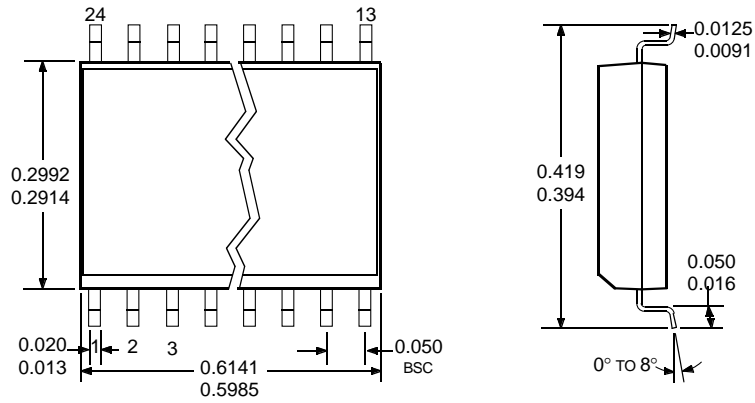

Dwg. MA-008-24A in

Dimensions in Millimeters
(controlling dimensions)

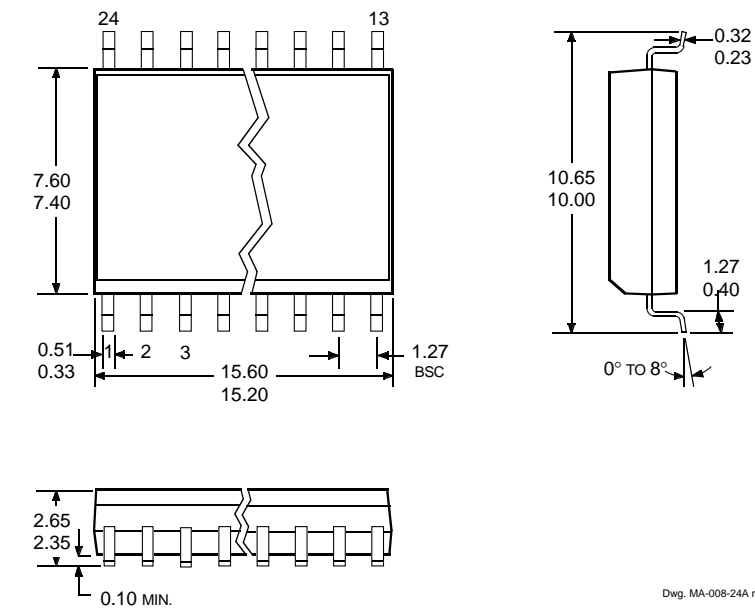

Dwg. MA-008-24A mm

- NOTES: 1. Exact body and lead configuration at vendor's option within limits shown.
 2. Lead spacing tolerance is non-cumulative.

A6800/A6801

DABiC-5 Latched Sink Drivers

Datasheet
26180.110

The products described here are manufactured under one or more U.S. patents or U.S. patents pending.

Allegro MicroSystems, Inc. reserves the right to make, from time to time, such departures from the detail specifications as may be required to permit improvements in the performance, reliability, or manufacturability of its products. Before placing an order, the user is cautioned to verify that the information being relied upon is current.

Allegro products are not authorized for use as critical components in life-support devices or systems without express written approval.

The information included herein is believed to be accurate and reliable. However, Allegro MicroSystems, Inc. assumes no responsibility for its use; nor for any infringement of patents or other rights of third parties which may result from its use.

Copyright©2003, 2004, 2005 Allegro Microsystems, Inc.

