

### Surface Mount Ultra Fast Rectifiers

**(Pb)** Lead(Pb)-Free

#### Features:

- \* For Surface Mount Application
- \* Glass Passivated Chip
- \* Low Reverse Leakage Current
- \* Low Forward Voltage Drop And High Current Capability
- \* Ultra Fast Switching For High Efficiency
- \* Plastic Meterial Has UL Flammability Classification 94V-0

**REVERSE VOLTAGE  
50 TO 1000 VOLTS  
FORWARD CURRENT  
1.0 AMPERE**



**SMA(DO-214AC)**

#### Mechanical Data

- \* Case : Molded Plastic
- \* Terminals: Solder Plated Terminal-Solderable per MIL-STD-202, Method 208
- \* Polarity :Indicated by cathode band
- \* Weight : 0.002 Ounce ,0.064 grams

### SMA Outline Dimension

Unit:mm

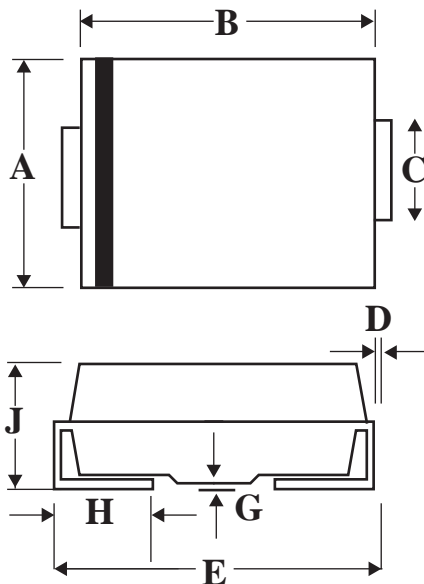

SMA		
Dim	Min	Max
A	2.20	2.92
B	4.00	4.60
C	1.27	1.63
D	0.15	0.31
E	4.48	5.59
G	0.10	0.20
H	0.76	1.52
J	1.70	2.62

## Maximum Ratings and Electrical Characteristics

Rating 25°C Ambient Temperature Unless Otherwise Specified.

Single Phase Half Wave, 60Hz , Resistive or Inductive Load.

For Capacitive Load, Derate Current by 20%.

Characteristics	Symbol	US1A	US1B	US1D	US1G	US1J	US1K	US1M	Unit
Maximum Recurrent Peak Reverse Voltage	VRRM	50	100	200	400	600	800	1000	V
Maximum RMS Voltage	VRMS	35	70	140	280	420	560	700	
Maximum DC Blocking Voltage	VDC	50	100	200	400	600	800	1000	
Maximum Average Forward Rectified Current @ $T_T=75^\circ\text{C}$	IF(AV)	1.0							A
Peak Forward Surge Current, 8.3 ms Single Half Sine-Wave Superimposed on Rated Load (JEDEC Method)	IFSM	30							A
Maximum Instantaneous At 1.0A DC	VF	1.0		1.30	1.70				V
Maximum DC Reverse Current @ $T_A=25^\circ\text{C}$ At Rated DC Blocking Voltage @ $T_A=100^\circ\text{C}$	IR	5.0			100				uA
Maximum Reverse Recovery Time(Note1)	Trr	50			100			nS	
Typical Junction Capacitance (Note 2)	C <sub>J</sub>	20			10			P <sub>F</sub>	
Typical Thermal Resistance (Note 3)	R <sub>θJT</sub>	75							°C/W
Operating Temperature Range	T <sub>J</sub>	-55 to+150							°C
Storage Temperature Range	TSTG	-55 to+150							°C

NOTES:1.Reverse Recovery Test Conditions:  $I_F=0.5\text{A}$ ,  $I_R=1.0\text{A}$ ,  $I_{RR}=0.25\text{A}$ .

2.Measured at 1.0MHz applied reverse voltage of 4.0V DC.

3.Unit Mounted on PC board with 5.0 mm<sup>2</sup>(0.03mm thick) land areas.

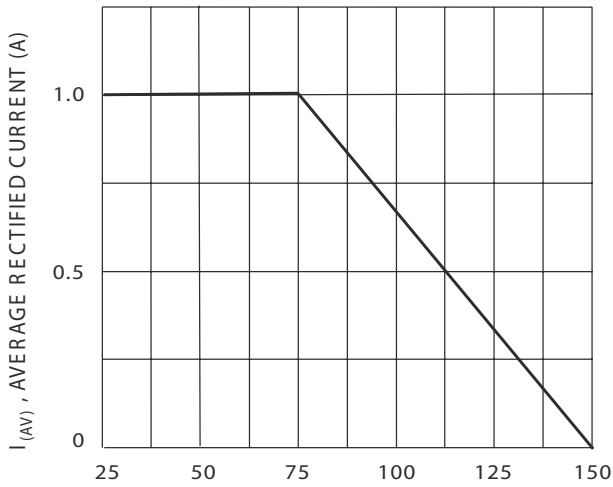

$T_T$ , TERMINAL TEMPERATURE (°C)  
FIG.1 Forward Current Derating Curve

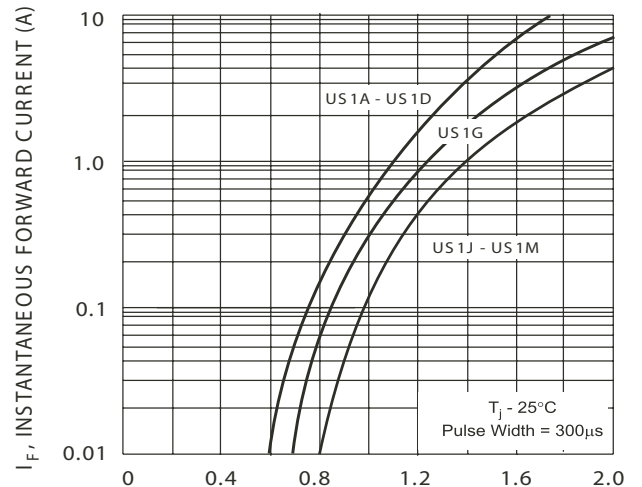

$V_F$ , INSTANTANEOUS FORWARD VOLTAGE (V)  
FIG.2 Typical Forward Characteristics

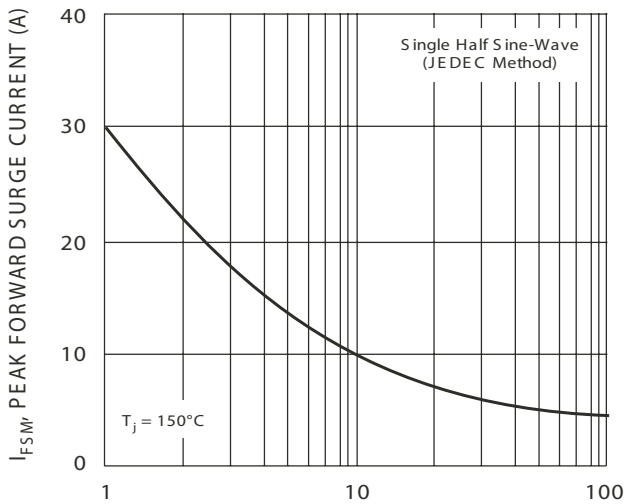

NUMBER OF CYCLES AT 60Hz  
FIG.3 Forward Surge Current Derating Curve

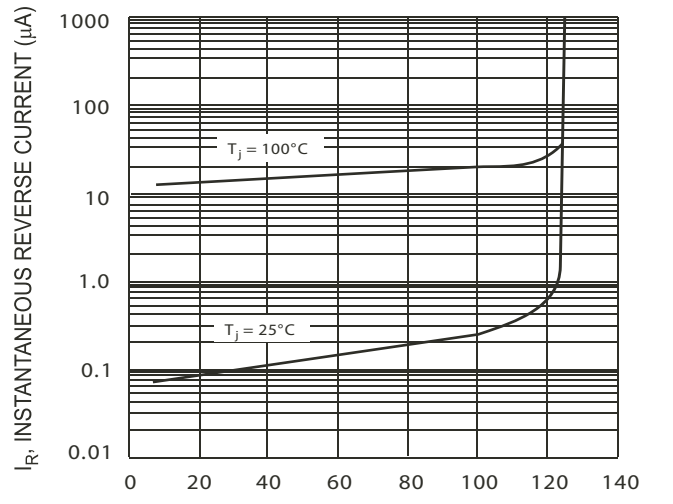

PERCENT OF RATED PEAK REVERSE VOLTAGE (%)  
FIG.4 Typical Reverse Characteristics

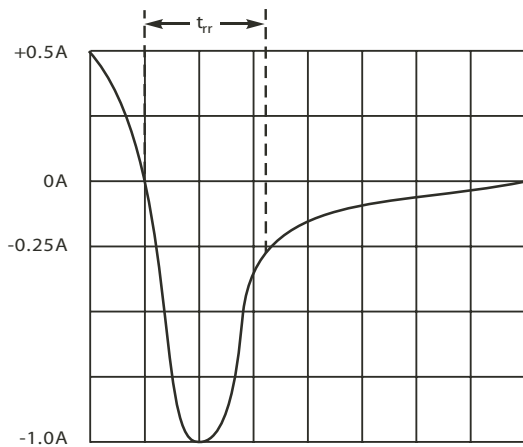

Set time base for 50/100 ns/cm

FIG.5 Reverse Recovery Time Characteristic and Test Circuit

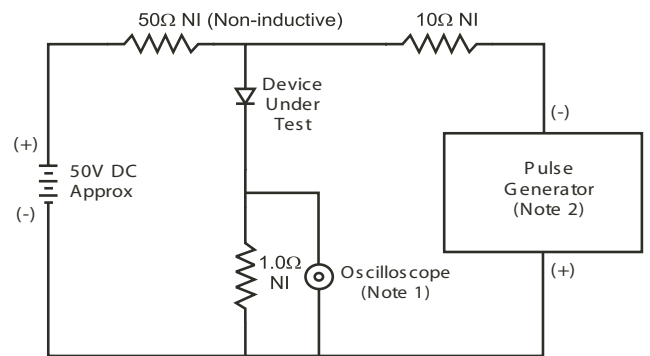

- Notes:  
1. Rise Time = 7.0ns max. Input Impedance = 1.0MΩ, 22pF.  
2. Rise Time = 10ns max. Input Impedance = 50Ω.