

PRELIMINARY SPEC

Part Number: KA-1011SEC28

Reddish-Orange

Features

- PLCC-4 PACKAGE.
- SINGLE COLOR.
- HIGH LUMINANCE.
- HIGH POWER, OPERATING CURRENT @350mA.
- SUITABLE FOR ALL SMT ASSEMBLY METHODS.
- PACKAGE : 500PCS / REEL.
- MOISTURE SENSITIVITY LEVEL : LEVEL 4.
- PATENT PENDING.
- RoHS COMPLIANT.

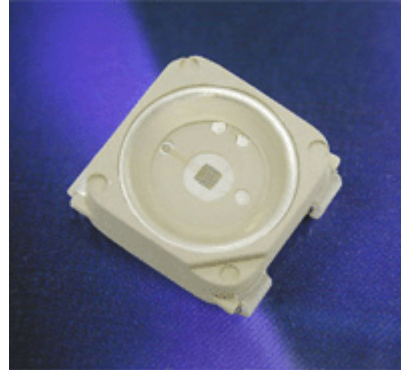

Applications

- traffic signaling
- backlighting (illuminated advertising , general lighting)
- interior and exterior automotive lighting
- substitution of micro incandescent lamps
- portable light source (e.g. bicycle flashlight)
- signal and symbol luminaire for orientation
- marker lights (e.g. steps, exit ways, etc)
- decorative and entertainment lighting
- indoor and outdoor commercial and residential architectural lighting

Package Dimensions

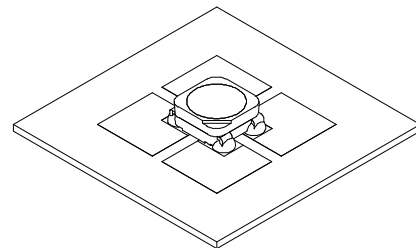
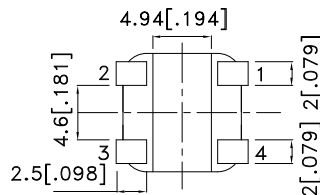
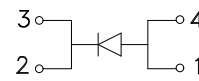
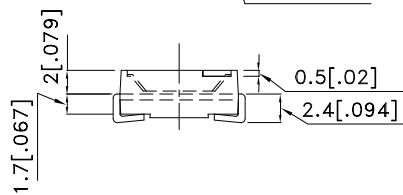
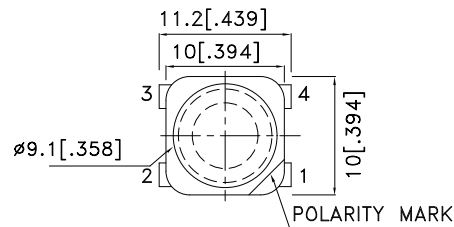

Notes:

1. All dimensions are in millimeters (inches).
2. Tolerance is $\pm 0.25(0.01")$ unless otherwise noted.
3. Specifications are subject to change without notice.
4. The device has a single mounting surface. The device must be mounted according to the specifications.



Selection Guide

Part No.	Dice	Lens Type	Luminous Intensity [2] Iv(cd)@ 350mA		Φv (lm) [2] @ 350mA		Viewing Angle [1]
			Min.	Typ.	Min.	Typ.	2θ1/2
KA-1011SEC28	Reddish-Orange (InGaAlP)	WATER CLEAR	24	40	15	22	60°

Notes:

1. θ1/2 is the angle from optical centerline where the luminous intensity is 1/2 the optical centerline value.
2. Luminous intensity / luminous Flux: +/-15%.

Absolute Maximum Ratings at TA=25°C

Parameter	Symbol	Value	Unit
Power dissipation	Pt	1.2	W
Reverse Voltage	VR	5	V
Junction temperature	TJ	110	°C
Operating Temperature	Top	-40 To +85	°C
Storage Temperature	Tstg	-40 To +85	°C
DC Forward Current [1]	IF	350	mA
Peak Forward Current [2]	IFM	500	mA
Thermal resistance [1]	Rth	60	°C/W

Notes:

1. Results from mounting on PC board FR4 (pad size ≥ 100mm² per pad), mounted on pc board-metal core PCB is recommend for lowest thermal Resistance.
2. 1/10 Duty Cycle, 0.1ms Pulse Width.

Electrical / Optical Characteristics at TA=25°C

Parameter	Symbol	Value	Unit
Wavelength at peak emission IF=350mA [Typ.]	λpeak	640	nm
Dominant Wavelength IF=350mA [Typ.]	λdom [1]	625	nm
Spectral bandwidth at 50%ΦREL MAX IF=350mA [Typ.]	Δλ	30	nm
Forward Voltage IF=350mA [Min.]	VF [2]	2.0	V
Forward Voltage IF=350mA [Typ.]		2.5	
Forward Voltage IF=350mA [Max.]		3.0	
Reverse Current (VR=5V) [Max.]	IR	10	μA
Temperature coefficient of λpeak IF=350mA, -10°C ≤ T ≤ 100°C [Typ.]	TCλpeak	0.14	nm/°C
Temperature coefficient of λdom IF=350mA, -10°C ≤ T ≤ 100°C [Typ.]	TCλdom	0.12	nm/°C
Temperature coefficient of VF IF=350mA, -10°C ≤ T ≤ 100°C [Typ.]	TCV	-3.0	mV/°C

Notes:

1. Wavelength: +/-1nm.
2. Forward Voltage: +/-0.1V.

KA-1011SEC28

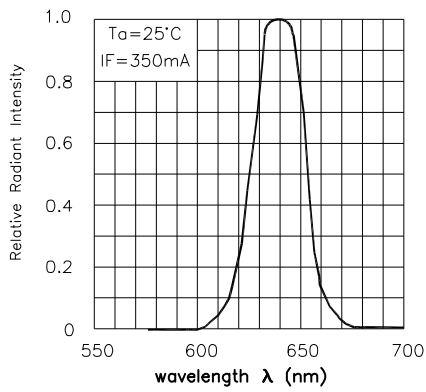

RELATIVE INTENSITY Vs. WAVELENGTH

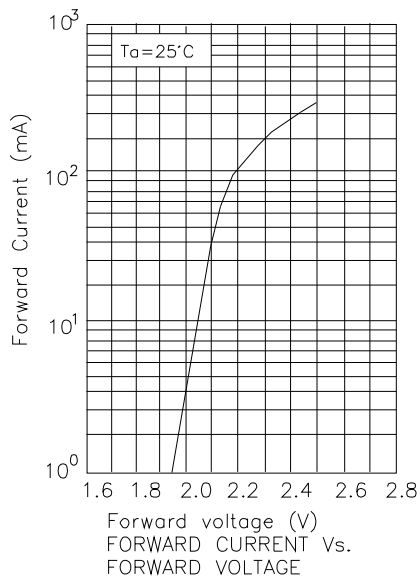
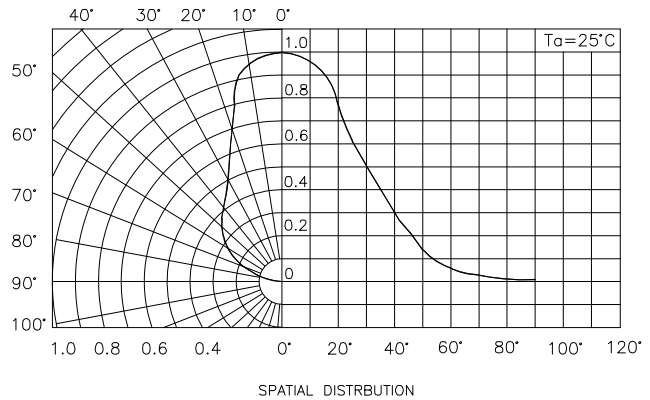

FORWARD CURRENT Vs. FORWARD VOLTAGE

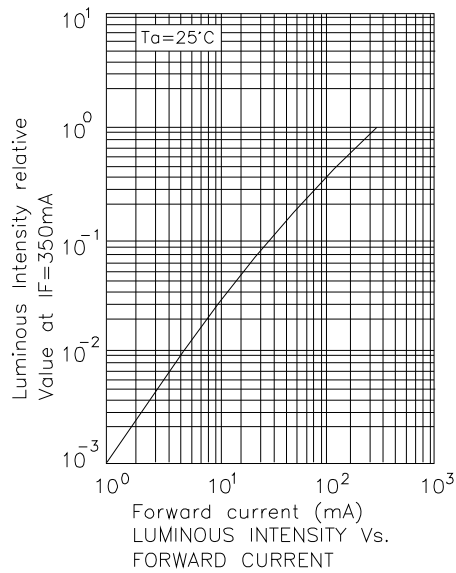

LUMINOUS INTENSITY Vs. FORWARD CURRENT

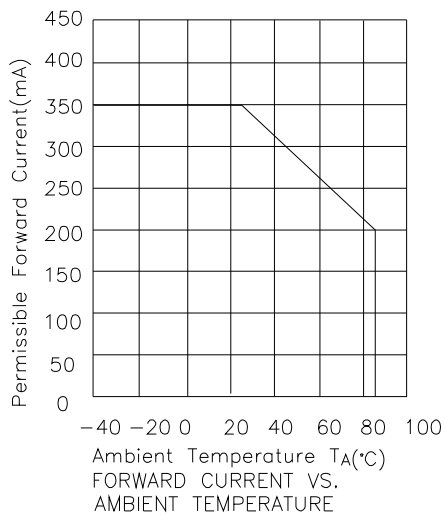

FORWARD CURRENT Vs. AMBIENT TEMPERATURE

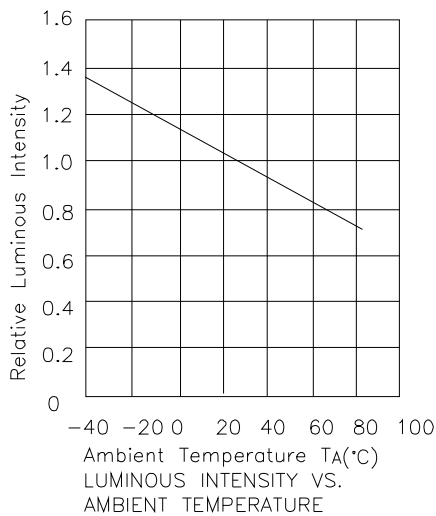

LUMINOUS INTENSITY Vs. AMBIENT TEMPERATURE

KA-1011SEC28

Reflow Soldering Profile For Lead-free SMT Process.

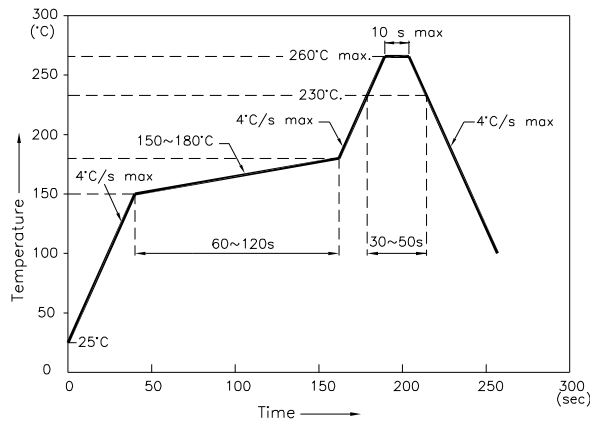

NOTES:

1. We recommend the reflow temperature 245°C (+/-5°C). The maximum soldering temperature should be limited to 260°C.
2. Don't cause stress to the epoxy resin while it is exposed to high temperature.
3. Number of reflow process shall be 2 times or less.

Recommended Soldering Pattern (Units : mm; Tolerance: ±0.1)

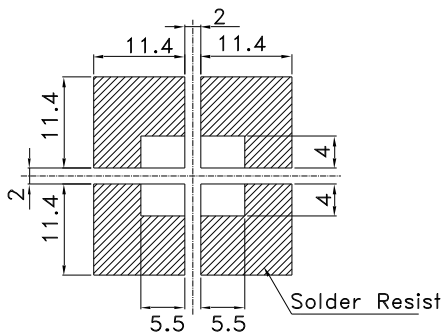

Reel Dimension

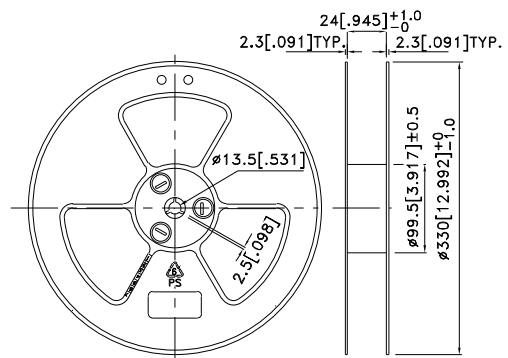

Tape Specifications (Units : mm)

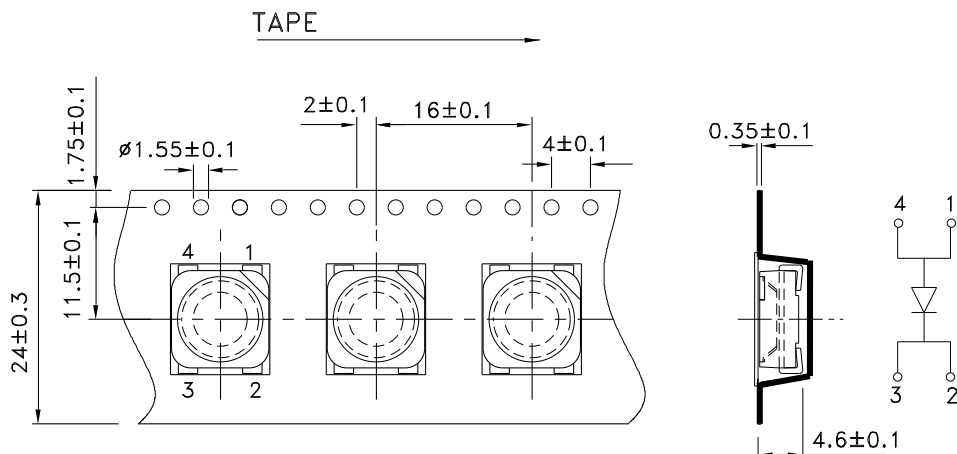

Kingbright

PACKING & LABEL SPECIFICATIONS

KA-1011SEC28

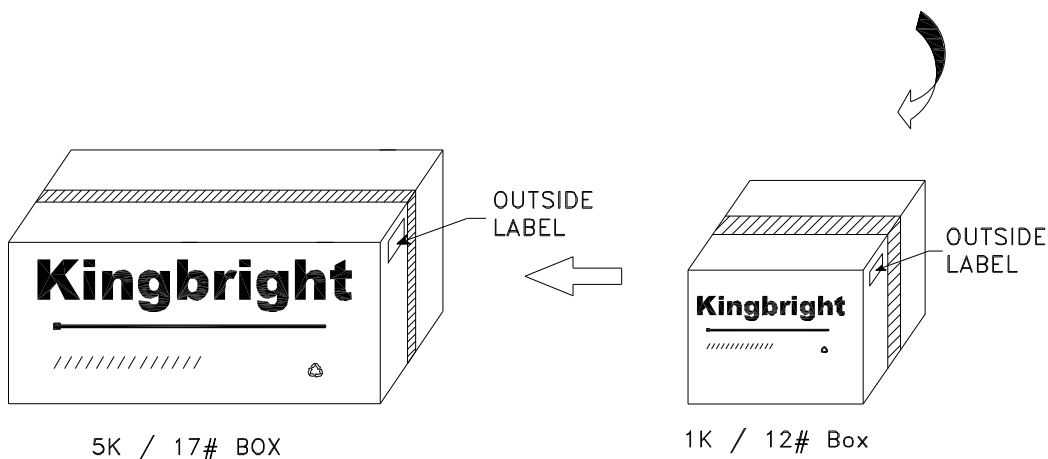
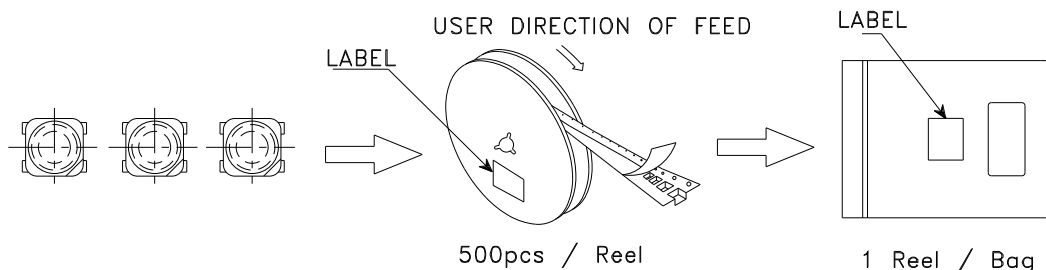

<h1>Kingbright</h1>	
P/NO: KA-1011XXX	
QTY: 500 pcs	Q.C. Q C xx xx xxxx PASSED
S/N: XXXX	
CODE: XXX	
LOT NO:	
 xxxxxxxxxxxxxxxxxxxxxxxxxxxx	
RoHS Compliant	