

## FEATURES

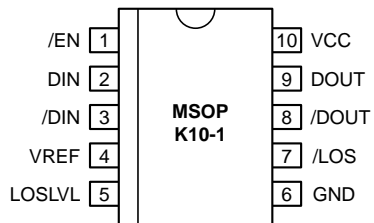
- 3.3V and 5V power supply options
- Up to 1.5Gbps operation
- Low power
- Low noise
- Chatter-Free /LOS Generation
- PECL /LOS Output
- TTL /EN Input
- Differential PECL inputs for data
- /EN input is TTL with internal 27K pull up
- Single power supply
- Designed for use with Micrel-Synergy laser diode driver and controller
- Available in a tiny 10-pin (3mm) MSOP

## DESCRIPTION

The SY88913V limiting post amplifier with its high gain and wide bandwidth is ideal for use as a post amplifier in fiber-optic receivers with data rates up to 1.5Gbps. Signals as small as 5mVp-p can be amplified to drive devices with PECL inputs. The SY88913V generates a chatter-free PECL Loss of Signal (/LOS) output.

The SY88913V incorporates a programmable level detect function to identify when the input signal has been lost. This information can be fed back to the /EN input of the device to maintain stability under loss of signal conditions. Using  $LOS_{LVL}$  pin the sensitivity of the level detect can be adjusted. The  $LOS_{LVL}$  voltage can be set by connecting a resistor divider between  $V_{CC}$  and  $V_{REF}$ . Figure 2, Figure 3 and 4 show the relationship between input level sensitivity and the voltage set on  $LOS_{LVL}$ .

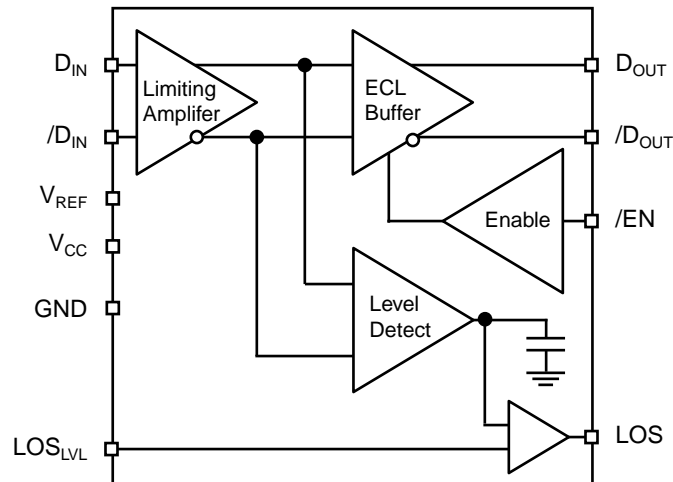
## PIN CONFIGURATION



## APPLICATIONS

- 1.25Gbps Gigabit Ethernet
- 531Mbps and 1062Mbps Fibre Channel
- 622Mbps SONET
- Gigabit Interface Converter

## BLOCK DIAGRAM



**PIN NAMES**

| Pin                | Type         | Function  |
|--------------------|--------------|---|
| D <sub>IN</sub>    | Data Input   | Data Input  |
| /D <sub>IN</sub>   | Data Input   | Inverting Data Input                                    |
| LOS <sub>LVL</sub> | Input        | Loss of Signal Level Set                                |
| /EN                | TTL Input    | Output Enable (active Low)                              |
| /LOS               | PECL Output  | Loss of Signal Indicator (active Low)                   |
| GND                | Ground       | Ground  |
| D <sub>OUT</sub>   | PECL Output  | Data Output   |
| /D <sub>OUT</sub>  | PECL Output  | Inverting Data Output                                   |
| V <sub>CC</sub>    | Power Supply | Positive Power Supply                                   |
| V <sub>REF</sub>   | Output       | Reference Voltage Output for LOS Level Set (see Fig. 2) |

**GENERAL DESCRIPTION****General**

The SY88913V is an integrated limiting amplifier intended for high-frequency fiber-optic applications. The circuit connects to typical transimpedance amplifiers found within a fiber-optics link. The linear signal output from a transimpedance amplifier can contain significant amounts of noise, and may vary in amplitude over time. The SY88913V limiting amplifier quantizes the signal and outputs a voltage-limited waveform.

The TTL /EN pin allows the user to disable the signal without removing the input signal.

**ABSOLUTE MAXIMUM RATINGS<sup>(1)</sup>**

| Symbol                                      | Rating                         | Value  | Unit |
|---|--------------------------------|--|------|
| V <sub>CC</sub>                             | Power Supply Voltage           | 0 to +7.0                                    | V    |
| D <sub>IN</sub> , /D <sub>IN</sub>          | Input Voltage                  | 0 to V <sub>CC</sub>                         | V    |
| D <sub>OUT</sub> , /D <sub>OUT</sub> , /LOS | Output Voltage (with 50Ω load) | V <sub>CC</sub> -2.5 to V <sub>CC</sub> +0.3 | V    |
| LOS <sub>LVL</sub>                          | Input Voltage                  | 0 to V <sub>CC</sub>                         | V    |
| V <sub>REF</sub>                            | Output Voltage                 | V <sub>CC</sub> -2.0 to V <sub>CC</sub>      | V    |
| T <sub>A</sub>                              | Operating Temperature Range    | -40 to +85                                   | °C   |
| T <sub>store</sub>                          | Storage Temperature Range      | -55 to +125                                  | °C   |

**NOTE:**

1. Permanent device damage may occur if ABSOLUTE MAXIMUM RATINGS are exceeded. This is a stress rating only and functional operation is not implied at conditions other than those detailed in the operational sections of this data sheet. Exposure to ABSOLUTE MAXIMUM RATING conditions for extended periods may affect device reliability.

**DC ELECTRICAL CHARACTERISTICS**

$V_{CC} = +3.3V \pm 10\%$  or  $+5V \pm 10\%$ ,  $R_{LOAD} = 50\Omega$  to  $V_{CC} - 2V$

| Symbol       | Parameter                            | $T_A = -40^\circ C$ |                    | $T_A = 0^\circ C$   |                    | $T_A = +25^\circ C$ |                 |                 | $T_A = +85^\circ C$ |                     | Unit               |         |
|--------------|--------------------------------------|---------------------|--------------------|---------------------|--------------------|---------------------|-----------------|-----------------|---------------------|---------------------|--------------------|---------|
|              |                                      | Min.                | Max.               | Min.                | Max.               | Min.                | Typ.            | Max.            | Min.                | Max.                |                    |         |
| $I_{CC}$     | Power Supply Current <sup>(1)</sup>  | 5V                  | —                  | 35                  | —                  | 35                  | —               | 21              | 35                  | —                   | 40                 | mA      |
|              |                                      | 3.3V                | —                  | 35                  | —                  | 35                  | —               | 23              | 35                  | —                   | 40                 |         |
| $I_{IL}$     | /EN Input LOW Current                | -0.3 <sup>(5)</sup> | —                  | -0.3 <sup>(5)</sup> | —                  | -0.3 <sup>(5)</sup> | —               | —               | —                   | -0.3 <sup>(5)</sup> | —                  | mA      |
| $I_{IH}$     | /EN Input HIGH Current               | —                   | 20 <sup>(2)</sup>  | —                   | 20 <sup>(2)</sup>  | —                   | —               | —               | 20 <sup>(2)</sup>   | —                   | 20 <sup>(2)</sup>  | $\mu A$ |
|              |                                      | —                   | 100 <sup>(3)</sup> | —                   | 100 <sup>(3)</sup> | —                   | —               | —               | 100 <sup>(3)</sup>  | —                   | 100 <sup>(3)</sup> |         |
| $V_{CMR}$    | Common Mode Range                    | GND +2.0            | $V_{CC} - 1.0$     | GND +2.0            | $V_{CC} - 1.0$     | GND +2.0            | —               | $V_{CC} - 1.0$  | GND +2.0            | $V_{CC} - 1.0$      | V                  |         |
| $V_{offset}$ | Differential Output Offset           | —                   | $\pm 100$          | —                   | $\pm 100$          | —                   | $\pm 40$        | $\pm 100$       | —                   | $\pm 100$           | mV                 |         |
| $LOS_{LVL}$  | $LOS_{LVL}$ Level                    | $V_{REF}$           | $V_{CC}$           | $V_{REF}$           | $V_{CC}$           | $V_{REF}$           | —               | $V_{CC}$        | $V_{REF}$           | $V_{CC}$            | V                  |         |
| $V_{OH}$     | $D_{OUT}$ and $/D_{OUT}$ HIGH Output | $V_{CC} - 1085$     | $V_{CC} - 880$     | $V_{CC} - 1025$     | $V_{CC} - 880$     | $V_{CC} - 1025$     | $V_{CC} - 955$  | $V_{CC} - 880$  | $V_{CC} - 1025$     | $V_{CC} - 880$      | mV                 |         |
| $V_{OL}$     | $D_{OUT}$ and $/D_{OUT}$ LOW Output  | $V_{CC} - 1830$     | $V_{CC} - 1555$    | $V_{CC} - 1810$     | $V_{CC} - 1620$    | $V_{CC} - 1810$     | $V_{CC} - 1705$ | $V_{CC} - 1620$ | $V_{CC} - 1810$     | $V_{CC} - 1620$     | mV                 |         |
| $V_{REF}$    | Reference Supply <sup>(4)</sup>      | $V_{CC} - 1.38$     | $V_{CC} - 1.26$    | $V_{CC} - 1.38$     | $V_{CC} - 1.26$    | $V_{CC} - 1.38$     | $V_{CC} - 1.32$ | $V_{CC} - 1.26$ | $V_{CC} - 1.38$     | $V_{CC} - 1.26$     | V                  |         |
| $V_{IH}$     | /EN Input HIGH Voltage               | 2.0                 | —                  | 2.0                 | —                  | 2.0                 | —               | —               | 2.0                 | —                   | V                  |         |
| $V_{IL}$     | /EN Input LOW Voltage                | —                   | 0.8                | —                   | 0.8                | —                   | —               | 0.8             | —                   | 0.8                 | V                  |         |

**NOTES:**

1. No Output Load.
2.  $V_{IN} = 2.7V$ .
3.  $V_{IN} = V_{CC}$ .

4.  $I_{REF}$  must be limited to be within  $-0.8mA$  (source) and  $0.5mA$  (sink).
5.  $V_{IN} = 0.5V$ .

**AC ELECTRICAL CHARACTERISTICS**

$V_{CC} = +3.3V \pm 10\%$  or  $+5V \pm 10\%$ ,  $R_{LOAD} = 50\Omega$  to  $V_{CC} - 2V$

| Symbol     | Parameter  | $T_A = -40^\circ C$ |      | $T_A = 0^\circ C$ |      | $T_A = +25^\circ C$ |                    |      | $T_A = +85^\circ C$ |      | Unit    | Conditions                                 |
|------------|--|---------------------|------|-------------------|------|---------------------|--------------------|------|---------------------|------|---------|--|
|            |  | Min.                | Max. | Min.              | Max. | Min.                | Typ.               | Max. | Min.                | Max. |         |  |
| PSRR       | Power Supply <sup>(1)</sup> Rejection Ratio      | —                   | —    | —                 | —    | —                   | 35                 | —    | —                   | —    | dB      | Input referred, 55MHz                      |
| $V_{ID}$   | Input Voltage Range                              | 5                   | 1800 | 5                 | 1800 | 5                   | —                  | 1800 | 5                   | 1800 | mVp-p   |  |
| $V_{OD}$   | Differential Output Voltage Swing <sup>(2)</sup> | —                   | —    | —                 | —    | —                   | 700                | —    | —                   | —    | mV      | $V_{ID} = 15mVp-p$<br>$V_{ID} = 5mVp-p$    |
|            |  | 200                 | —    | 200               | —    | 200                 | 250                | —    | 200                 | —    | mV      |  |
| $t_{OFFL}$ | /LOS Release Time <sup>(3)</sup> Minimum Input   | —                   | 0.5  | —                 | 0.5  | —                   | 0.1                | 0.5  | —                   | 0.5  | $\mu s$ |  |
| $t_{ONL}$  | /LOS Assert Time <sup>(3)</sup>                  | —                   | 0.5  | —                 | 0.5  | —                   | 0.2                | 0.5  | —                   | 0.5  | $\mu s$ |  |
| $t_{OFFH}$ | /LOS Release Time <sup>(4)</sup> Maximum Input   | —                   | 0.5  | —                 | 0.5  | —                   | 0.1                | 0.5  | —                   | 0.5  | $\mu s$ |  |
| $V_{SR}$   | /LOS Sensitivity Range                           | 5                   | 50   | 5                 | 50   | 5                   | —                  | 50   | 5                   | 50   | mVp-p   |  |
| HYS        | /LOS Hysteresis                                  | 2                   | 8    | 2                 | 8    | 2                   | 4.6                | 8    | 2                   | 8    | dB      |  |
| $t_r, t_f$ | Output Rise/Fall Time                            | —                   | 260  | —                 | 260  | —                   | 170                | 260  | —                   | 260  | ps      | $V_{ID} > 100mVp-p$<br>$V_{ID} < 100mVp-p$ |
|            |  | —                   | —    | —                 | —    | —                   | $t_{rin}, t_{fin}$ | —    | —                   | —    | —       |  |

**NOTES:**

1. Input referred noise = RMS output noise/low frequency gain.
2. Input is 622MHz square wave.

3. Input is a 200MHz square wave,  $t_r < 300ps$ ,  $8mVp-p$ .
4. Input is a 200MHz square wave,  $t_r < 300ps$ ,  $1.8Vp-p$ .

**APPLICATION NOTE**

**Output Termination**

The SY88913V outputs must be terminated with a 50Ω load to V<sub>CC</sub> -2V (or Thevenin equivalent).

**Layout and PCB Design**

Since the SY88913V is a high-frequency component, performance can largely be determined by board layout and design. A common problem with high-gain amplifiers is feedback from the large swing outputs to the input via the power supply.

The SY88913V ground pin should be connected to the circuit board ground. Use multiple PCB vias close to the part to connect to ground. Avoid long, inductive runs which can degrade performance.

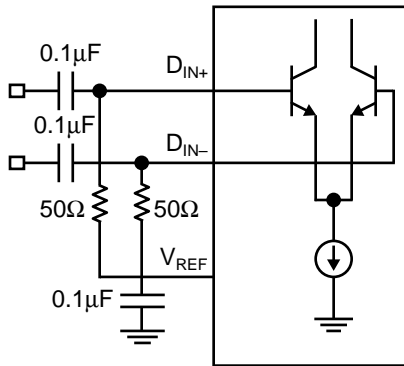


Figure 1. Differential Input Configuration

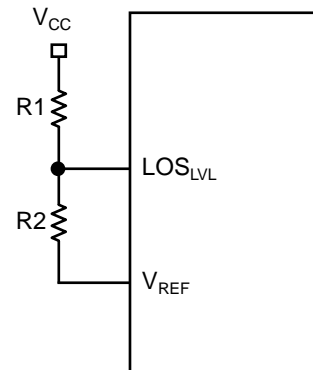


Figure 2. LOS<sub>LVL</sub> Circuit

**NOTES:**

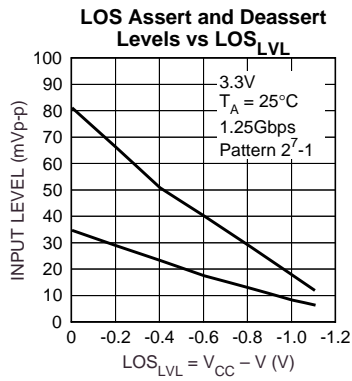
$$LOS_{LVL} = V_{CC} - 1.32 + \frac{R2 \times 1.32}{R1 + R2}$$

$$R1 + R2 \geq 5k\Omega$$

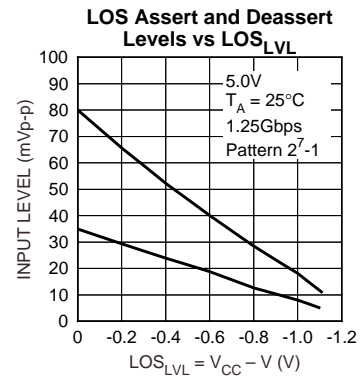
**PRODUCT ORDERING CODE**

| Ordering Code | Package Type | Operating Range |
|---------------|--------------|-----------------|
| SY88913VKC    | K10-1        | Commercial      |

**PERFORMANCE CURVE**

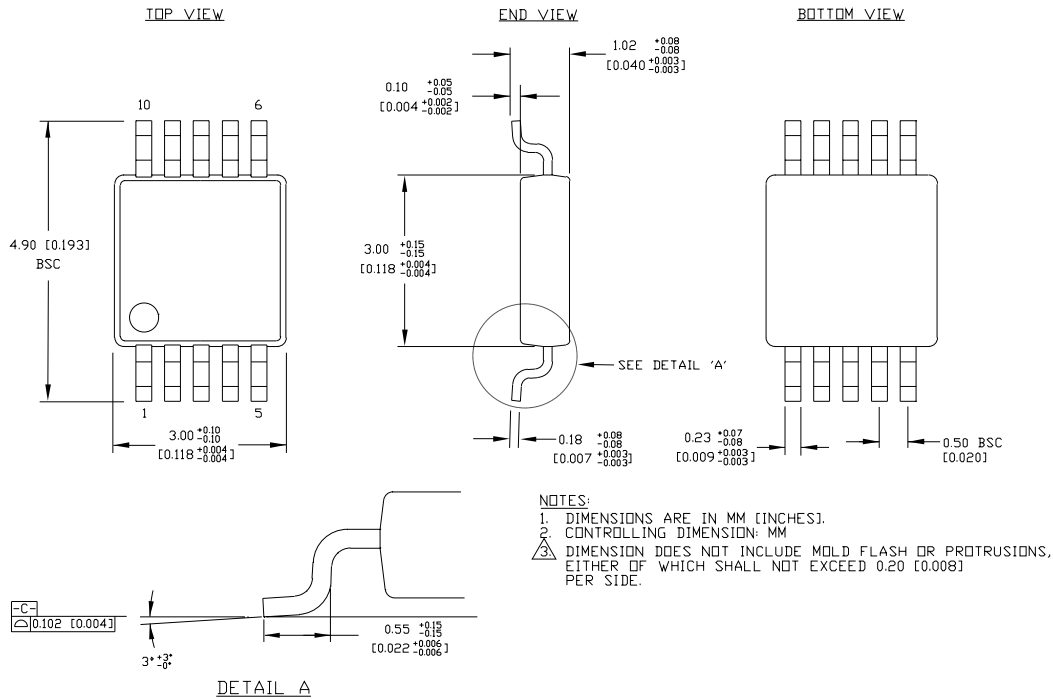


**Figure 3. 3.3V LOS Assert and Deassert Levels vs. LOS<sub>LVL</sub>**



**Figure 4. 5.0V LOS Assert and Deassert Levels vs. LOS<sub>LVL</sub>**

**10 LEAD MSOP (K10-1)**



Rev. 00

**MICREL-SYNERGY 3250 SCOTT BOULEVARD SANTA CLARA CA 95054 USA**

TEL + 1 (408) 980-9191 FAX + 1 (408) 914-7878 WEB <http://www.synergysmi.com> <http://www.micrel.com>

This information is believed to be accurate and reliable, however no responsibility is assumed by Micrel for its use nor for any infringement of patents or other rights of third parties resulting from its use. No license is granted by implication or otherwise under any patent or patent right of Micrel Inc.

© 2000 Micrel Incorporated