

AME10 Series

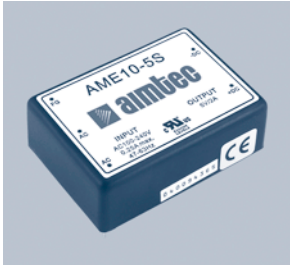

10 watt encapsulated ac-dc converter

- SWITCHING POWER MODULES FOR PCB MOUNTING
- FULLY ENCAPSULATED PLASTIC CASE
- UNIVERSAL INPUT RANGE 90 ... 260 VAC, 47 ... 440 Hz
- REGULATED OUTPUT
- LOW RIPPLE & NOISE
- HIGH EFFICIENCY
- CE, cUL APPROVALS

ELECTRICAL SPECIFICATIONS



All specifications valid at nominal Input voltage, full load and +25°C after warm-up time unless otherwise stated.

Model No. (Single Output)		AME10-3.3S	AME10-5S	AME10-12S	AME10-15S	AME10-24S
Max output wattage (W)		10W	10W	10W	10W	10W
Input	Voltage	90 ... 260 VAC or 120 ... 370 VDC				
	Frequency (Hz)	47 ... 440 Hz				
	Current (Full Load)	200mA max. (115 VAC) / 130mA max. (230 VAC)				
	Inrush Current (<2ms)	10 A max. (115 VAC) / 20 A max. (230VAC)				
	Leakage Current	0.75mA max.				
	External Fuse (recommended)	1.5 A slow blow type				
Output	Voltage (VDC)	3.3V	5V	12V	15V	24V
	Voltage Accuracy	±2%				
	Current (mA) max.	3000	2000	833	666	416
	Line Regulation (typ.)	±0.3%				
	Load Regulation (typ.)	±0.5%				
	Minimum Load	4%	5%	5%	3%	5%
	Maximum Capacitive Load	470-23,000m F depending on model				
	Noise	<0.5% Vout +50mV max (Vp-p)				
	Ripple	<0.2% Vout +40mV max (Vp-p)				
	Efficiency	68%	71%	76%	76%	80%
	Hold-up Time	15 ms min.				
	Switching Frequency	100 kHz				
	Protection	Over Current Protection	Hiccup technique, auto-recovery			
Over Voltage Protection		Zener diode clamp				
Short Circuit Protection		Hiccup mode, indefinite (automatic recovery)				
Isolation	Input-Output (VAC)	3000V				
	Input-FG (VAC)	1500V				
	Outut-FG (VAC)	500V				
Environment	Operating Temperature	-25°C ... +71°C				
	Storage Temperature	-40°C ... +85°C				
	Temperature Coefficient	0.02% / °C				
	Humidity	95% RH				
	MTBF	>230,000 h @ 25°C (MIL-HDBK-217F)				
Physical	Dimension (L x W x H)	2.52 x 1.77 x 0.81 inches (64.0 x 45.0 x 20.5 mm)				
	Case Material	Plastic resin + Fiberglass (flammability to UL 94V-0)				
	Weight	100g				
	Cooling Method	Free air convection				
Safety	Agency Approvals	cUL, CE				
EMC	EMI (Conducted & Radiated Emission)	EN 55022 class B				
	EMS (Noise Immunity)	EN 50082-1				

AME10 Series

10 watt encapsulated ac-dc converter

ELECTRICAL SPECIFICATIONS

All specifications valid at nominal Input voltage, full load and +25°C after warm-up time unless otherwise stated.

Model No. (Dual Output)		AME10-5D	AME10-12D	AME10-15D
Max output wattage (W)		10W	10W	10W
Input	Voltage	90 ... 260 VAC or 120 ... 370 VDC		
	Frequency (Hz)	47 ... 440 Hz		
	Current (Full Load)	200mA max. (115 VAC) / 130mA max. (230 VAC)		
	Inrush Current (<2ms)	10 A max. (115 VAC) / 20 A max. (230VAC)		
	Leakage Current	0.75mA max.		
	External Fuse (recommended)	1.5 A slow blow type		
Output	Voltage (VDC)	±5V	±12V	±15V
	Voltage Accuracy	±2%		
	Current (mA) max.	±800	±380	±300
	Line Regulation (typ.)	±0.3%		
	Load Regulation (typ.)	±0.5%		
	Minimum Load	1%	3%	1%
	Maximum Capacitive Load	470-23,000m F depending on model		
	Noise	<0.5% Vout +50mV max (Vp-p)		
	Ripple	<0.2% Vout +40mV max (Vp-p)		
	Efficiency	72%	77%	77%
	Hold-up Time	15 ms min.		
	Switching Frequency	100 kHz		
Protection	Over Current Protection	Hiccup technique, auto-recovery		
	Over Voltage Protection	Zener diode clamp		
	Short Circuit Protection	Hiccup mode, indefinite (automatic recovery)		
Isolation	Input-Output (VAC)	3000V		
	Input-FG (VAC)	1500V		
	Output-FG (VAC)	500V		
Environment	Operating Temperature	-25°C ... +71°C		
	Storage Temperature	-40°C ... +85°C		
	Temperature Coefficient	0.02% / °C		
	Humidity	95% RH		
	MTBF	>230,000 h @ 25°C (MIL-HDBK-217F)		
Physical	Dimension (L x W x H)	2.52 x 1.77 x 0.81 inches (64.0 x 45.0 x 20.5 mm)		
	Case Material	Plastic resin + Fiberglass (flammability to UL 94V-0)		
	Weight	100g		
	Cooling Method	Free air convection		
Safety	Agency Approvals	cUL, CE		
EMC	EMI (Conducted & Radiated Emission)	EN 55022 class B		
	EMS (Noise Immunity)	EN 50082-1		

Specifications are subject to change without notification

OUTLINE DIMENSIONS & PIN CONNECTIONS

MECHANICAL DIMENSION (Top View)

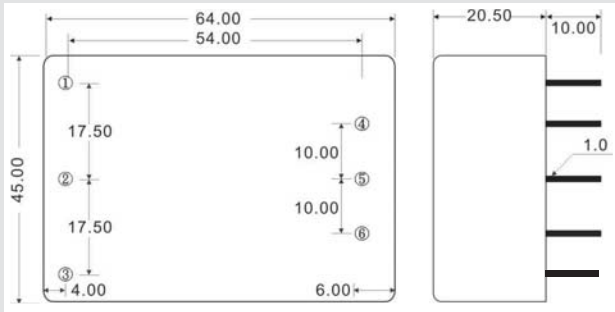

Pin	Single	Dual
1	FG	FG
2	AC Input (N)	AC Input (N)
3	AC Input (L)	AC Input (L)
4	-DC Output	-DC Output
5	Do not connect	Common
6	+DC Output	+DC Output

BLOCK DIAGRAM

Single Output

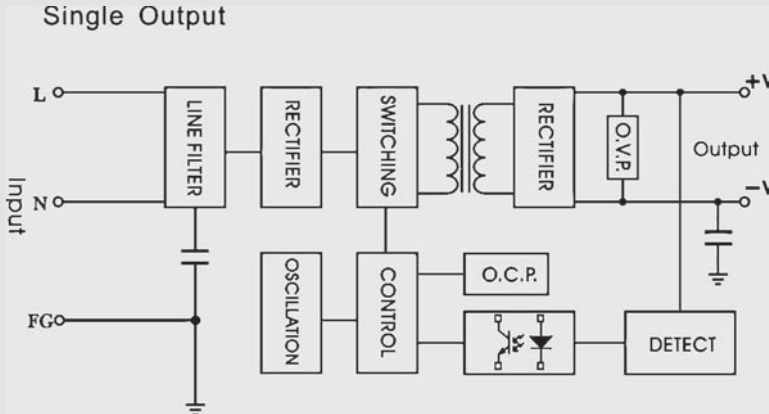

Dual Output

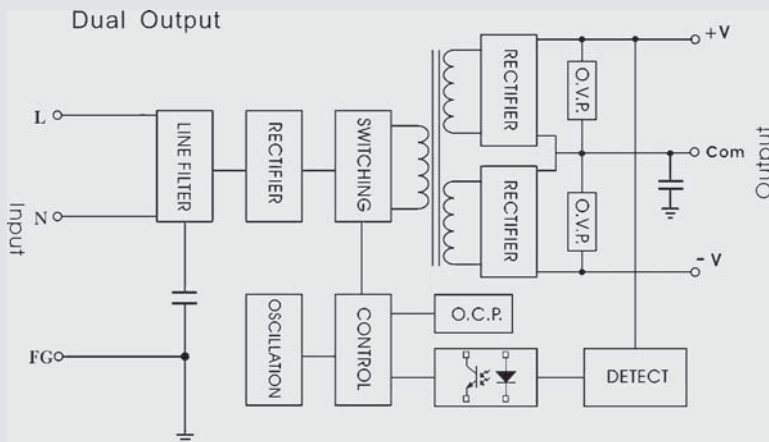

DERATING

