

FEATURES

- Logic-Level Gate Drive
- Avalanche Rugged Technology
- Rugged Gate Oxide Technology
- Lower Input Capacitance
- Improved Gate Charge
- Extended Safe Operating Area
- Lower Leakage Current : 10 μ A (Max.) @ $V_{DS} = 60V$
- Lower $R_{DS(on)}$: 0.02 Ω (Typ.)

$BV_{DSS} = 60 V$
 $R_{DS(on)} = 0.025 \Omega$
 $I_D = 50 A$

TO-220

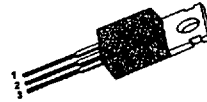

1. Gate 2. Drain 3. Source

Absolute Maximum Ratings

Symbol	Characteristic	Value	Units
V_{DSS}	Drain-to-Source Voltage	60	V
I_D	Continuous Drain Current ($T_C=25^\circ C$)	50	A
	Continuous Drain Current ($T_C=100^\circ C$)	35	
I_{DM}	Drain Current-Pulsed ①	175	A
V_{GS}	Gate-to-Source Voltage	± 20	V
E_{AS}	Single Pulsed Avalanche Energy ②	857	mJ
I_{AR}	Avalanche Current ①	50	A
E_{AR}	Repetitive Avalanche Energy ①	12.5	mJ
dv/dt	Peak Diode Recovery dv/dt ③	5.5	V/ns
P_D	Total Power Dissipation ($T_C=25^\circ C$)	125	W
	Linear Derating Factor	0.83	
T_J, T_{STG}	Operating Junction and Storage Temperature Range	- 55 to +175	$^\circ C$
T_L	Maximum Lead Temp. for Soldering Purposes, 1/8" from case for 5-seconds	300	

Thermal Resistance

Symbol	Characteristic	Typ.	Max.	Units
$R_{\theta JC}$	Junction-to-Case	--	1.2	$^\circ C/W$
$R_{\theta CS}$	Case-to-Sink	0.5	--	
$R_{\theta JA}$	Junction-to-Ambient	--	62.5	



IRLZ44A

N-CHANNEL POWER MOSFET

Electrical Characteristics ($T_C=25^\circ\text{C}$ unless otherwise specified)

Symbol	Characteristic	Min.	Typ.	Max.	Units	Test Condition
BV_{DSS}	Drain-Source Breakdown Voltage	60	–	–	V	$V_{GS}=0V, I_D=250\mu\text{A}$
$\Delta BV/\Delta T_J$	Breakdown Voltage Temp. Coeff.	–	0.056	–	V/ $^\circ\text{C}$	$I_D=250\mu\text{A}$ See Fig 7
$V_{GS(th)}$	Gate Threshold Voltage	1.0	–	2.0	V	$V_{DS}=5V, I_D=250\mu\text{A}$
I_{GSS}	Gate-Source Leakage, Forward	–	–	100	nA	$V_{GS}=20V$
	Gate-Source Leakage, Reverse	–	–	-100	nA	$V_{GS}=-20V$
I_{DSS}	Drain-to-Source Leakage Current	–	–	10	μA	$V_{DS}=60V$
		–	–	100		$V_{DS}=48V, T_C=150^\circ\text{C}$
$R_{DS(on)}$	Static Drain-Source On-State Resistance	–	–	0.025	Ω	$V_{GS}=5V, I_D=25A$ ④
g_{fs}	Forward Transconductance	–	40	–	S	$V_{DS}=30V, I_D=25A$ ④
C_{iss}	Input Capacitance	–	1530	1990	pF	$V_{GS}=0V, V_{DS}=25V, f=1\text{MHz}$ See Fig 5
C_{oss}	Output Capacitance	–	555	640		
C_{rss}	Reverse Transfer Capacitance	–	225	260		
$t_{d(on)}$	Turn-On Delay Time	–	14	40	ns	$V_{DD}=30V, I_D=50A,$ $R_G=4.6\Omega$ See Fig 13 ④ ⑤
t_r	Rise Time	–	24	60		
$t_{d(off)}$	Turn-Off Delay Time	–	43	95		
t_f	Fall Time	–	37	85		
Q_g	Total Gate Charge	–	42	55	nC	$V_{DS}=48V, V_{GS}=5V,$ $I_D=50A$ See Fig 6 & Fig 12 ④ ⑤
Q_{gs}	Gate-Source Charge	–	12	–		
Q_{gd}	Gate-Drain ("Miller") Charge	–	20	–		

Source-Drain Diode Ratings and Characteristics

Symbol	Characteristic	Min.	Typ.	Max.	Units	Test Condition
I_S	Continuous Source Current	–	–	50	A	Integral reverse pn-diode in the MOSFET
I_{SM}	Pulsed-Source Current ①	–	–	175		
V_{SD}	Diode Forward Voltage ④	–	–	1.8	V	$T_J=25^\circ\text{C}, I_S=50A, V_{GS}=0V$
t_{rr}	Reverse Recovery Time	–	72	–	ns	$T_J=25^\circ\text{C}, I_F=50A$
Q_{rr}	Reverse Recovery Charge	–	0.133	–	μC	$di_F/dt=100A/\mu\text{s}$ ④

Notes :

- ① Repetitive Rating : Pulse Width Limited by Maximum Junction Temperature
- ② $L=0.4\text{mH}, I_{AS}=50A, V_{DD}=25V, R_G=27\Omega,$ Starting $T_J=25^\circ\text{C}$
- ③ $I_{SD} \leq 50A, di/dt \leq 350A/\mu\text{s}, V_{DD} \leq BV_{DSS},$ Starting $T_J=25^\circ\text{C}$
- ④ Pulse Test : Pulse Width = 250 μs , Duty Cycle $\leq 2\%$
- ⑤ Essentially Independent of Operating Temperature

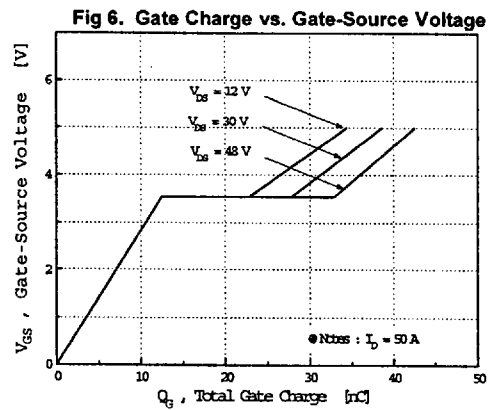
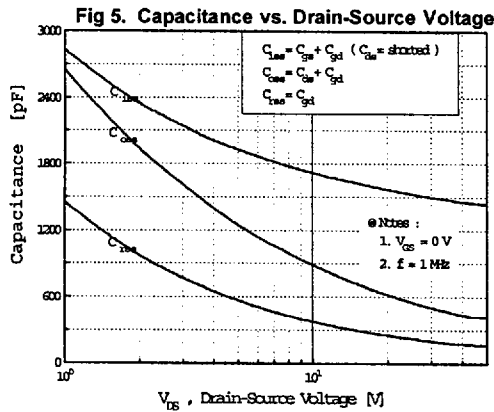
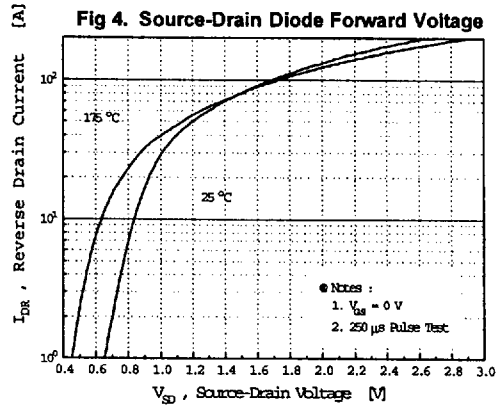
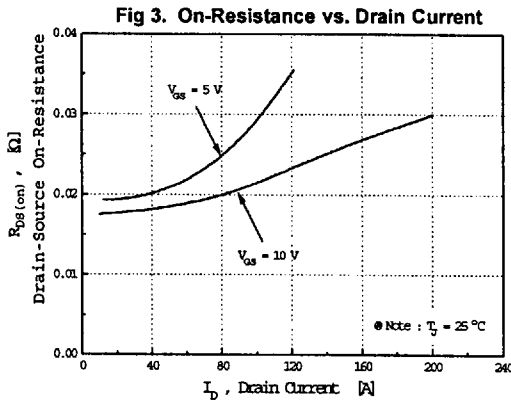
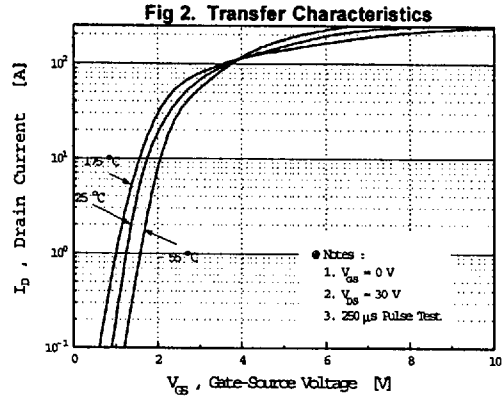
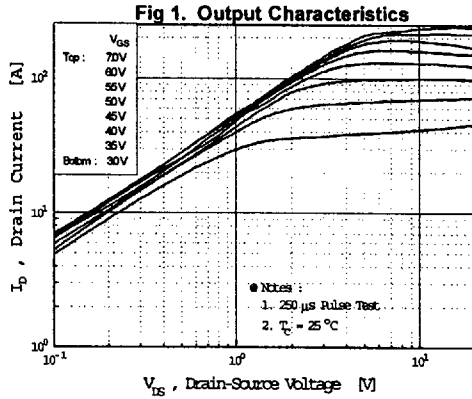

IRLZ44A

N-CHANNEL POWER MOSFET

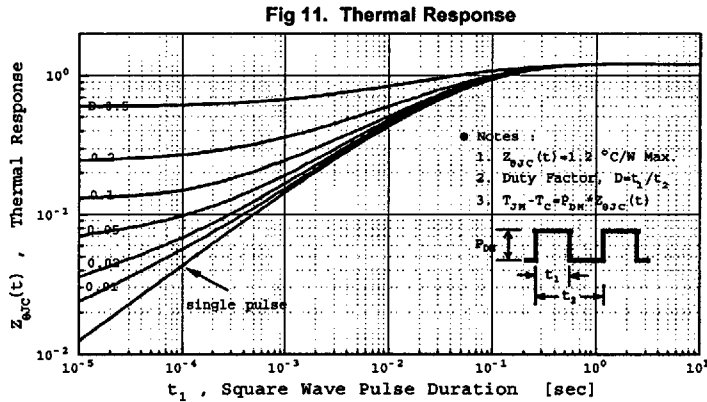
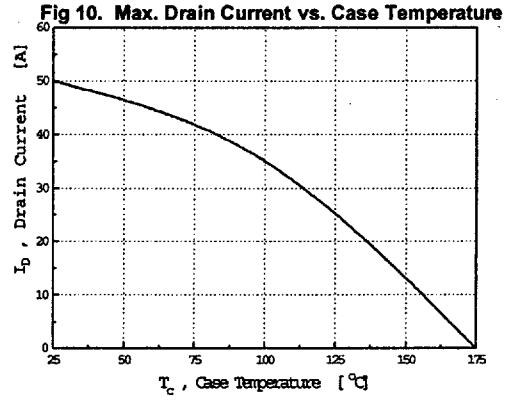
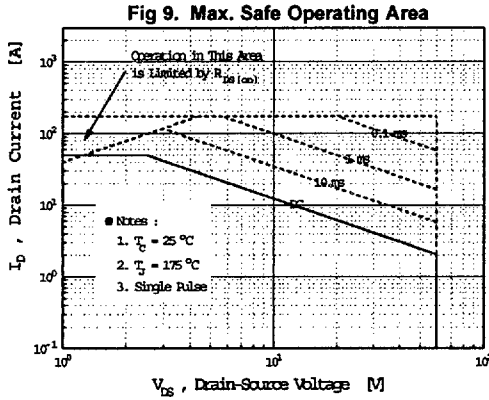
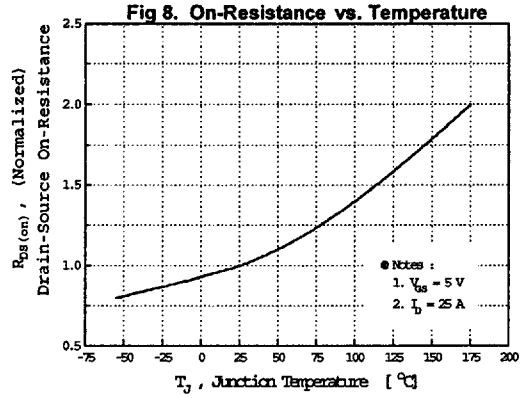
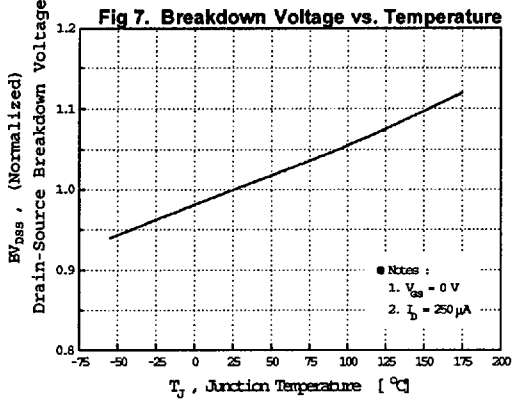

Fig 12. Gate Charge Test Circuit & Waveform

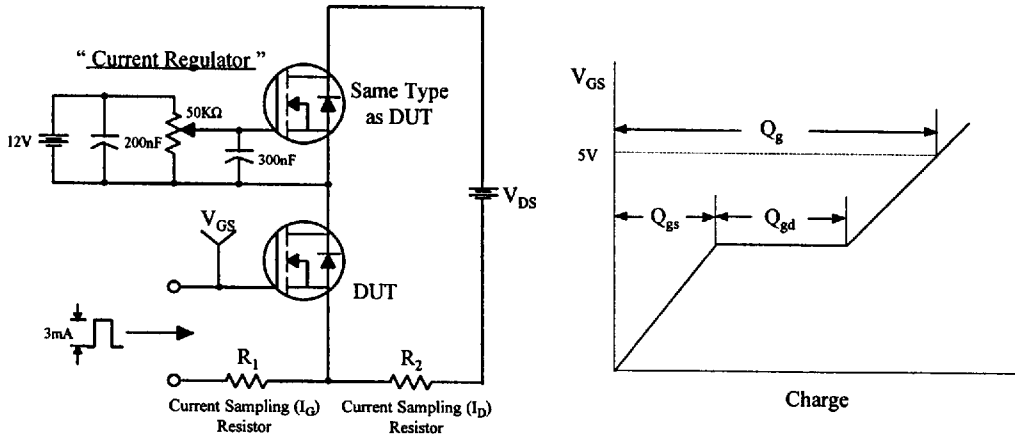

Fig 13. Resistive Switching Test Circuit & Waveforms

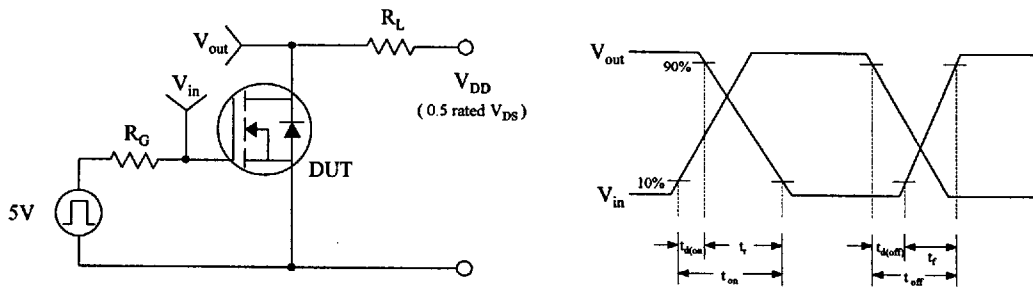

Fig 14. Unclamped Inductive Switching Test Circuit & Waveforms

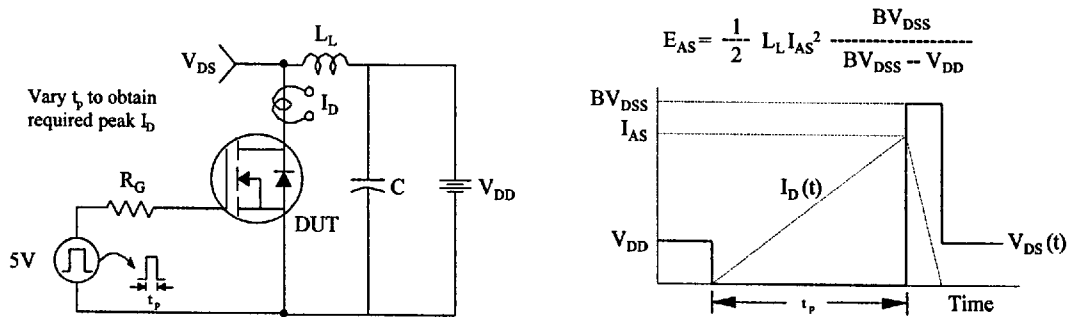
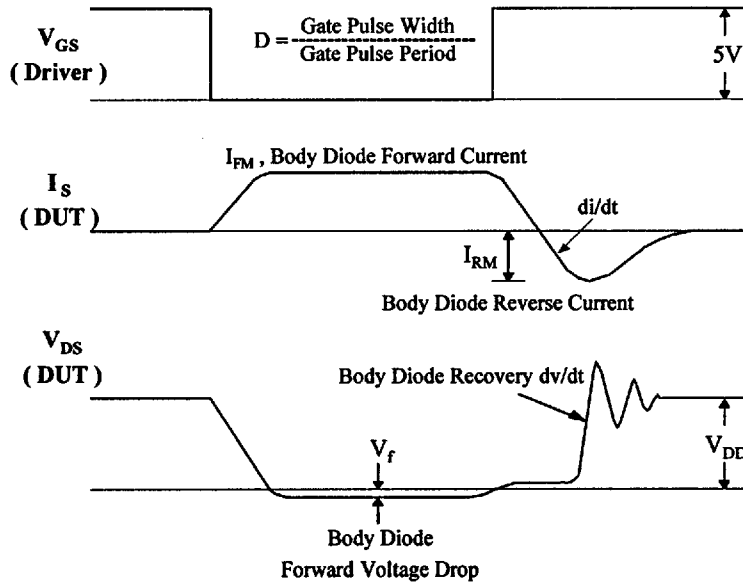
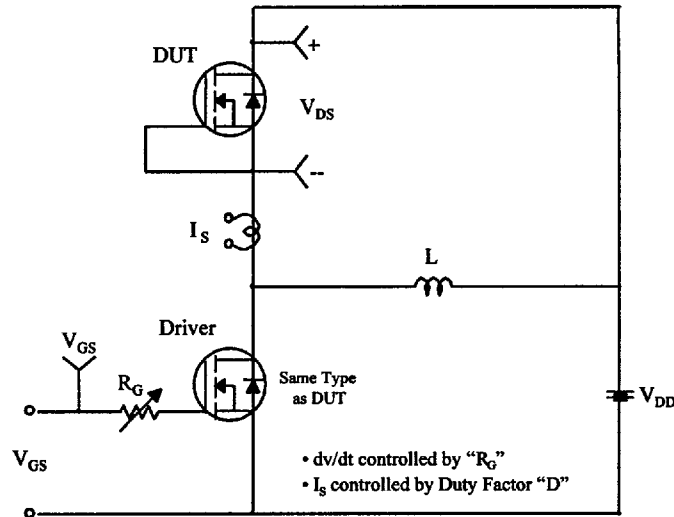
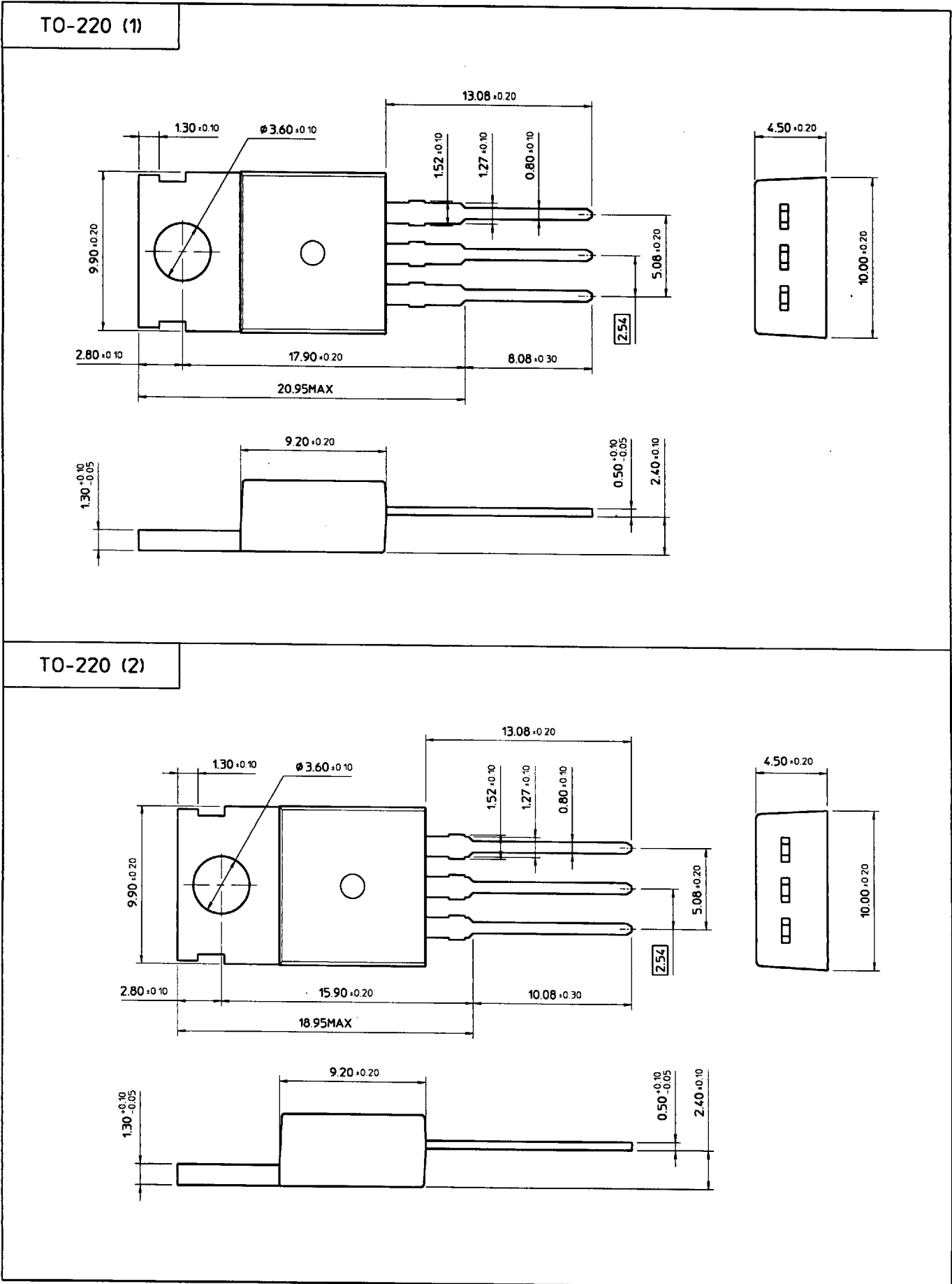
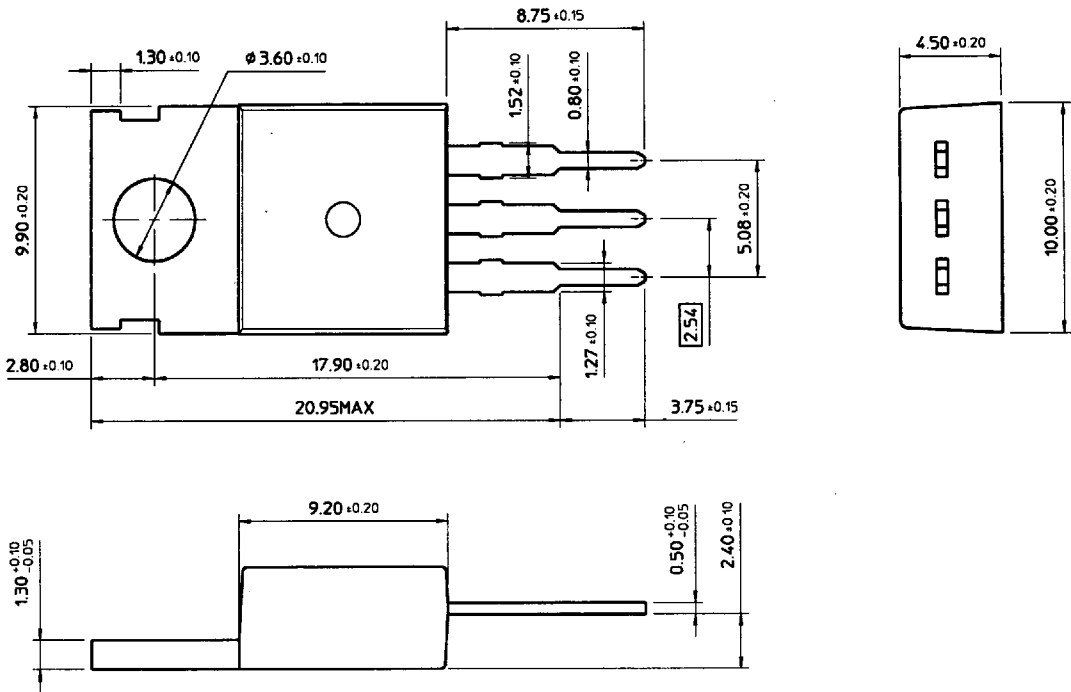

Fig 15. Peak Diode Recovery dv/dt Test Circuit & Waveforms





TO-220 (3)



TO-220 (4)

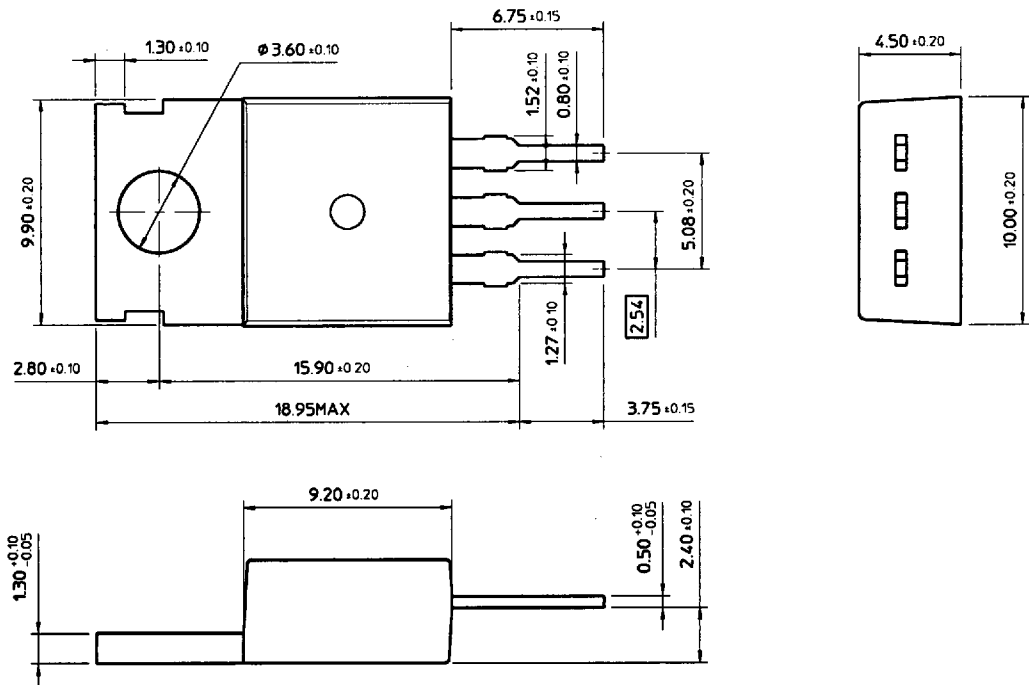

T0-220 (5)

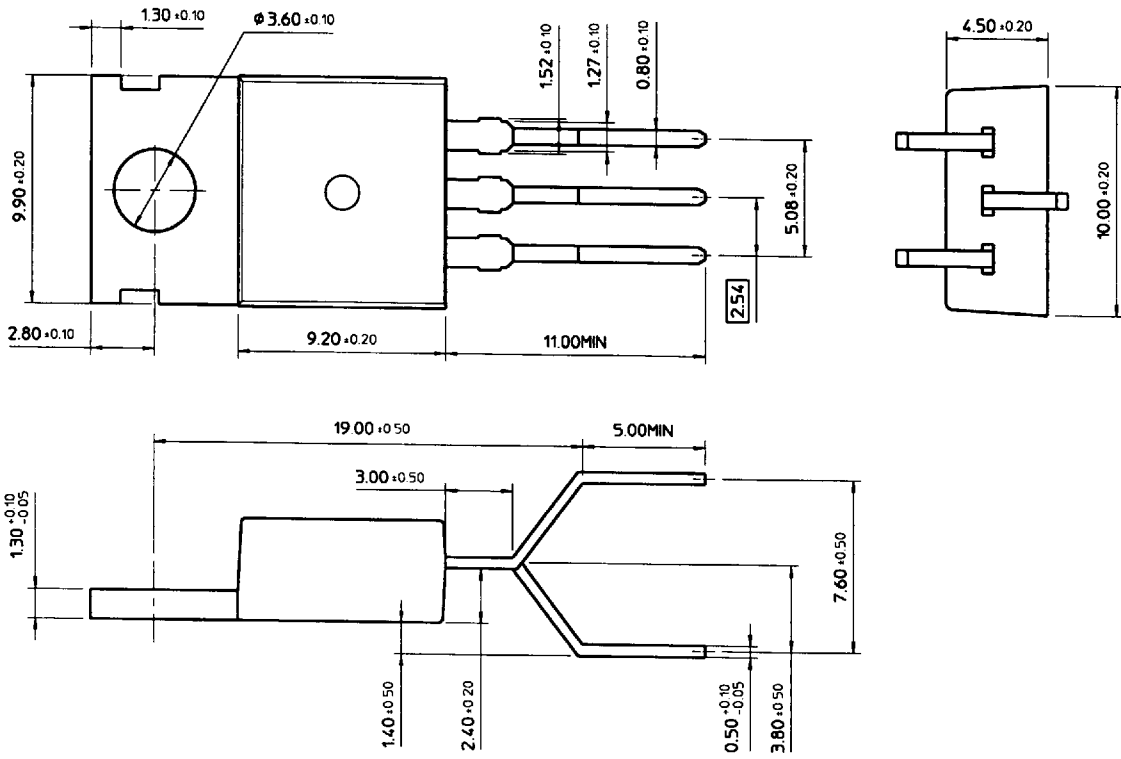

NOTE