

LT1Z□95A series

3528 Size, 1.9mm Thickness, Leadless Chip LED

Outline Dimensions

(Unit : mm)

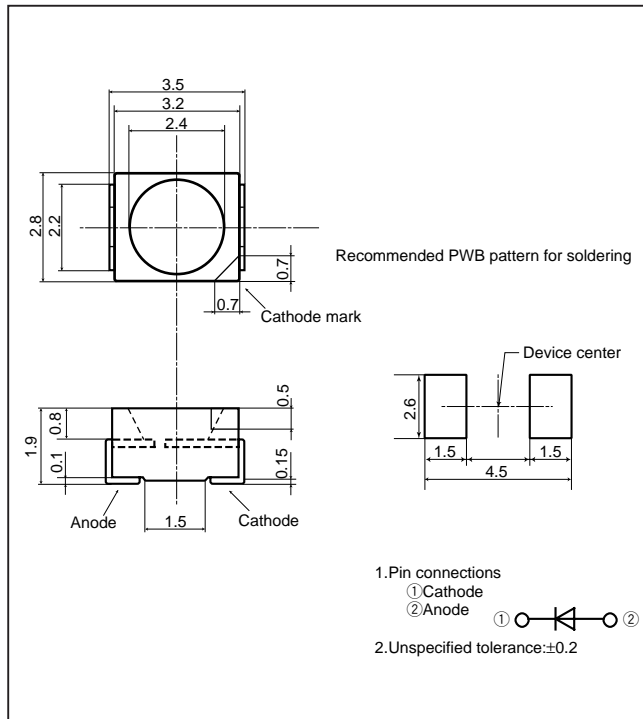

Radiation Diagram

(Ta=25°C)

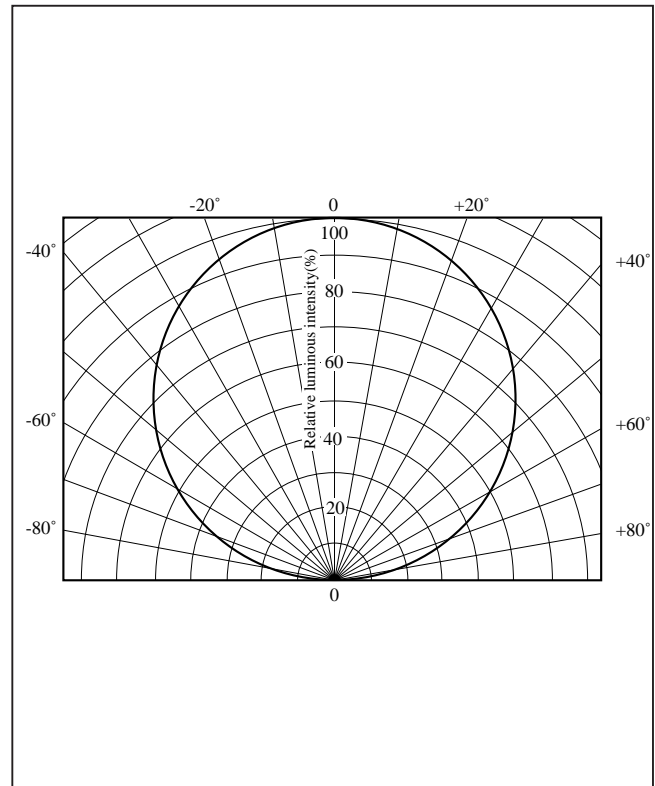

Absolute Maximum Ratings

(Ta=25°C)

Model No.	Radiation color	Radiation material	Power dissipation P (mW)	Forward current IF (mA)	Peak forward current IFM*1 (mA)	Derating factor (mA/°C)		Reverse voltage VR (V)	Operating temperature Topr (°C)	Storage temperature Tstg (°C)	Soldering temperature Tsol*2 (°C)
						DC	Pulse				
LT1ZR95A	Red	AlGaInP on GaAs	130	50	100	0.67	1.33	5	-55 to +110	-55 to +110	295
LT1ZJ95A	Orange	AlGaInP on GaAs	130	50	100	0.67	1.33	5	-55 to +110	-55 to +110	295
LT1ZS95A	Sunset orange	AlGaInP on GaAs	130	50	100	0.67	1.33	5	-55 to +110	-55 to +110	295
LT1ZV95A	Amber	AlGaInP on GaAs	130	50	100	0.67	1.33	5	-55 to +110	-55 to +110	295
LT1ZE95A	Yellow-green	AlGaInP on GaAs	130	50	100	0.67	1.33	5	-55 to +110	-55 to +110	295
LT1ZG95A	Green	AlGaInP on GaAs	130	50	100	0.67	1.33	5	-55 to +110	-55 to +110	295

*1 Duty ratio=1/10, Pulse width=0.1ms

*2 For 3s or less at the temperature of hand soldering. Temperature of reflow soldering is shown on the page 7.

Electro-optical Characteristics

(IF=20mA, Ta=25°C)

Lens type	Model No.	Forward voltage VF(V)		Peak emission wavelength λp(nm) TYP	Dominant wavelength λd(nm) TYP	Luminous intensity Iv(mcd) TYP	Spectrum radiation bandwidth Δλ(nm) TYP	Reverse current IR(μA) MAX	VR (V)	Terminal capacitance		Page for characteristics diagrams
		TYP	MAX							Ct(pF) TYP	(MHz)	
Colorless transparency	LT1ZR95A	2.1	2.6	647	635	90	20	100	4	60	1	142
	LT1ZJ95A	2.1	2.6	627	618	200	15	100	4	60	1	142
	LT1ZS95A	2.1	2.6	609	605	290	15	100	4	60	1	143
	LT1ZV95A	2.1	2.6	591	588	170	15	100	4	60	1	144
	LT1ZE95A	2.1	2.6	570	570	45	15	100	4	60	1	144
	LT1ZG95A	2.1	2.6	560	560	15	15	100	4	60	1	145

LED Lamp Characteristics Diagrams

ZR series

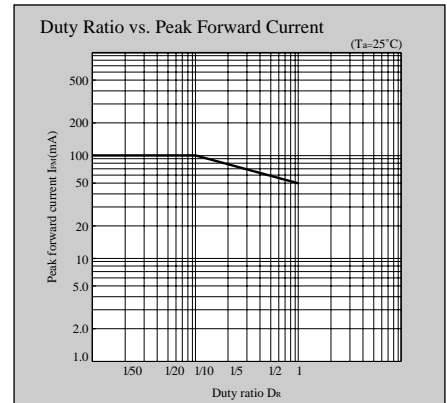
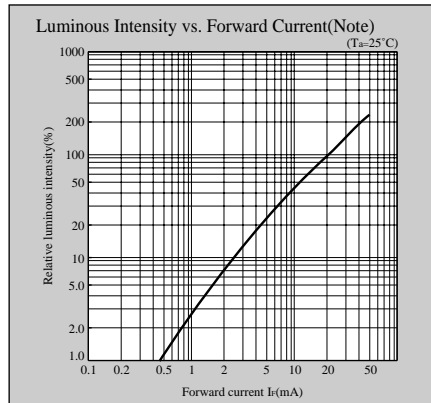
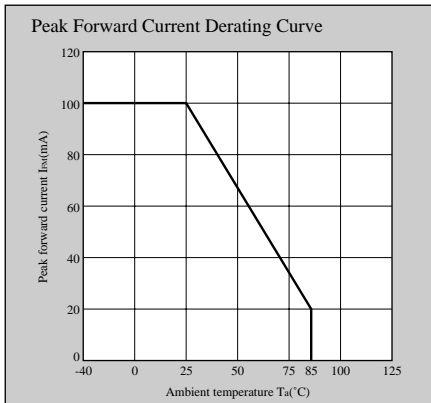
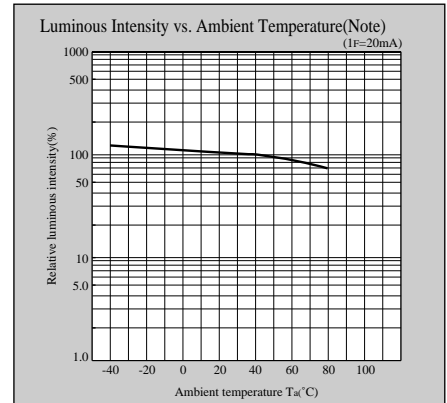
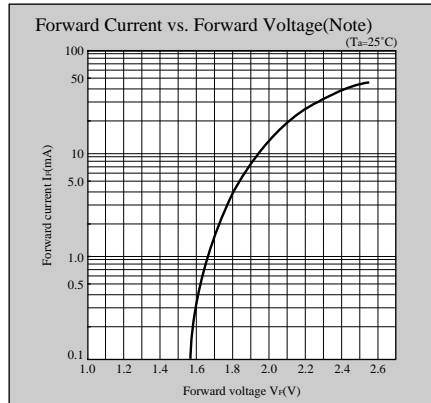
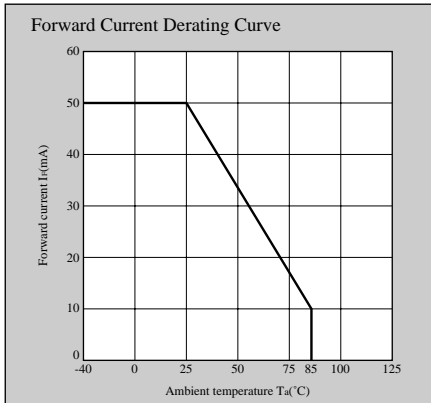

ZJ series

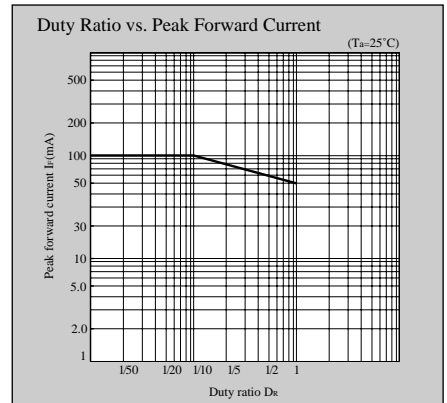
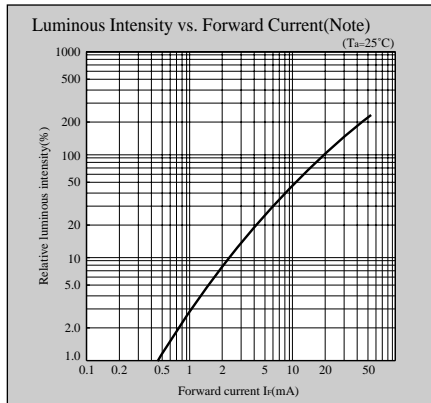
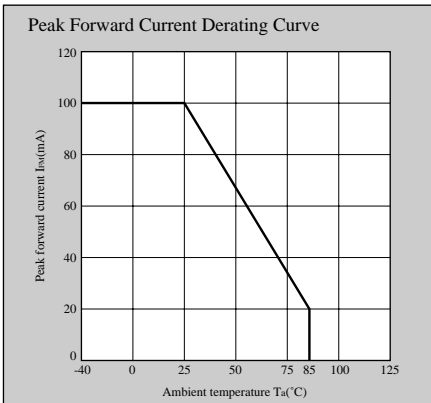
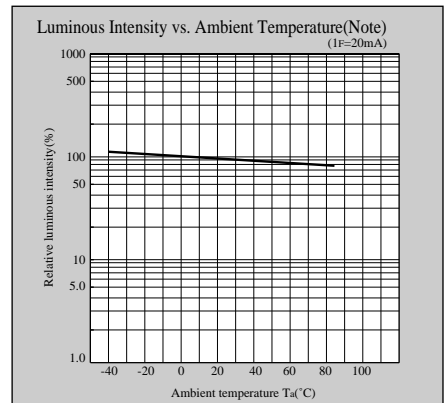
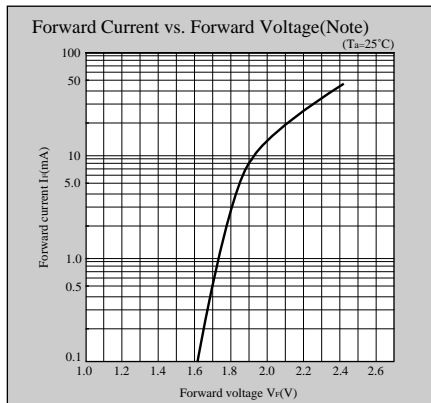
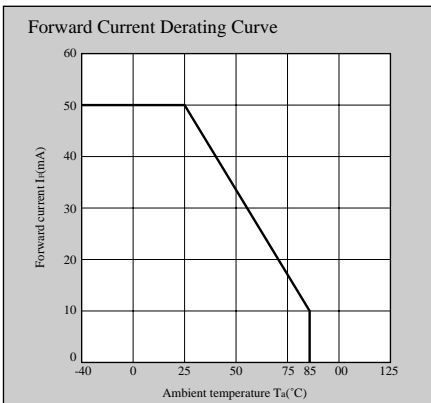

Note) Characteristics shown in diagrams are typical values. (not assurance value)

LED Lamp Characteristics Diagrams

ZS series

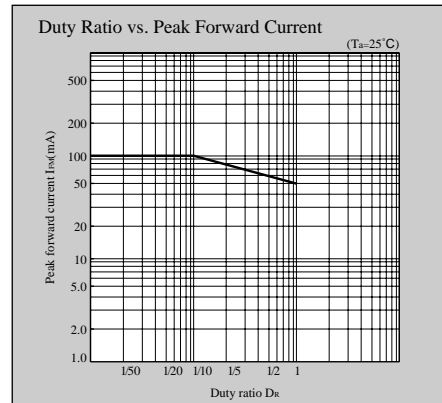
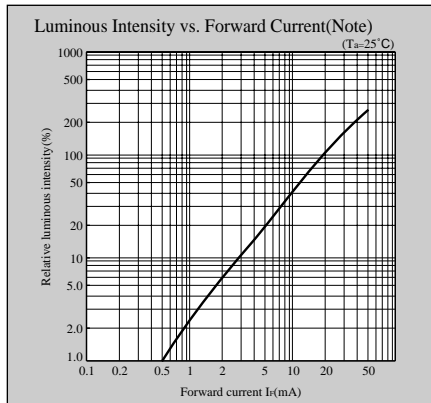
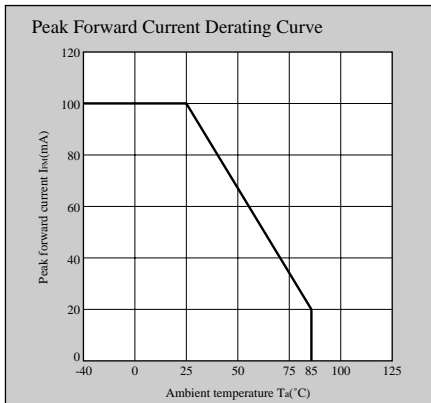
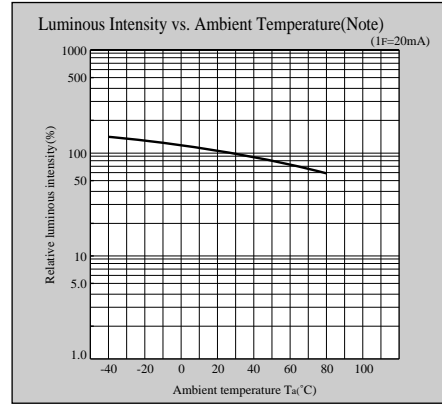
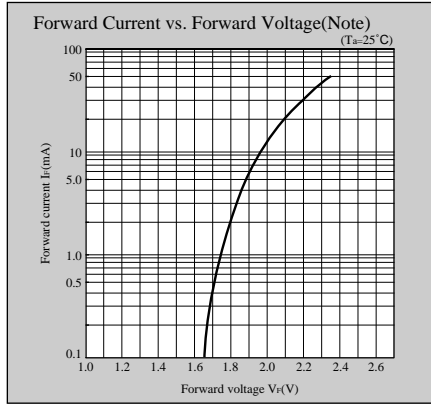
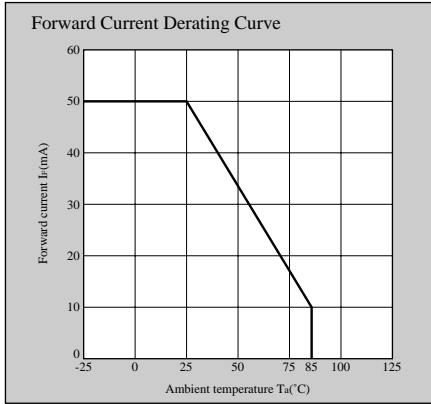

GL5XS022BOS

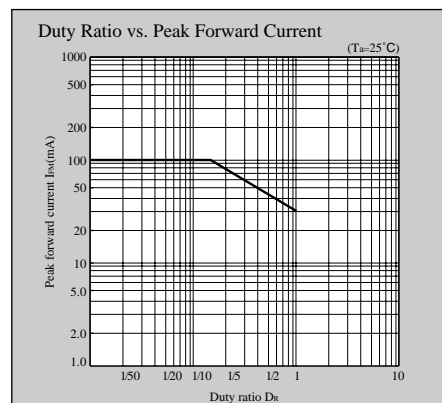
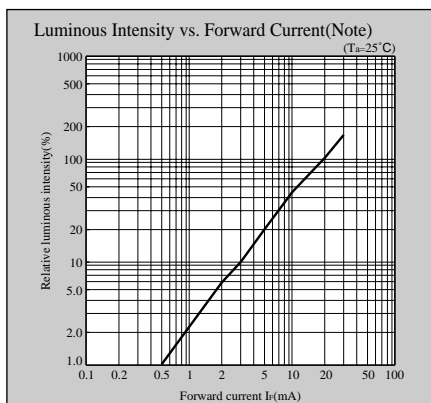
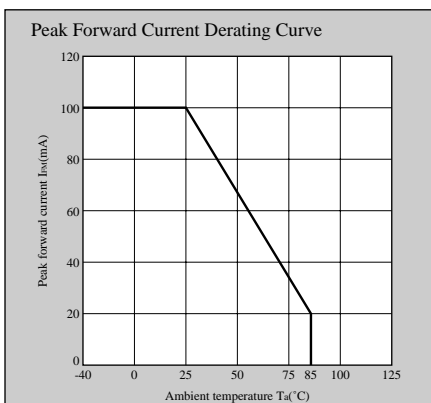
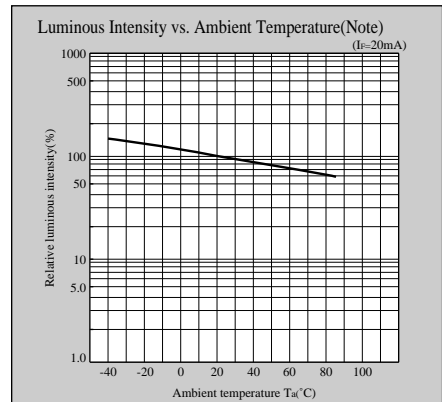
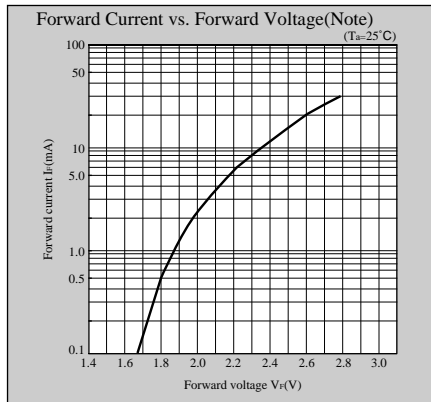
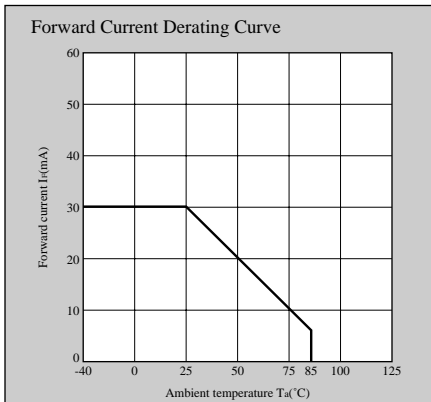

Note) Characteristics shown in diagrams are typical values. (not assurance value)

LED Lamp Characteristics Diagrams

ZV series

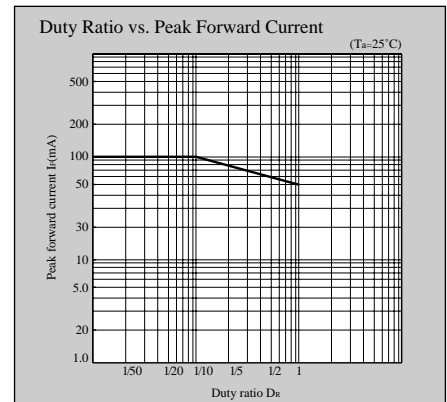
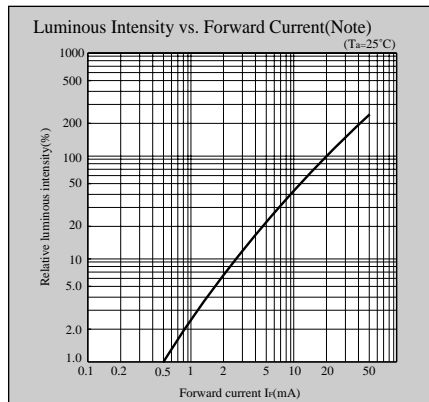
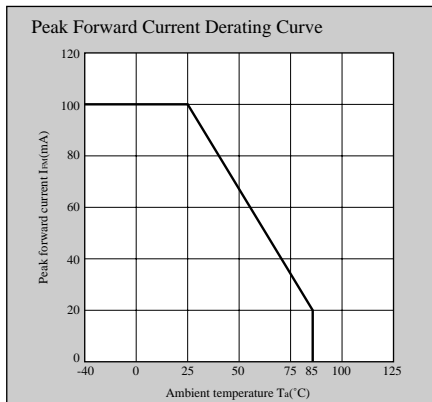
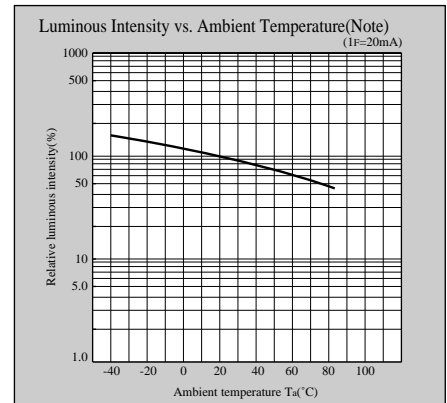
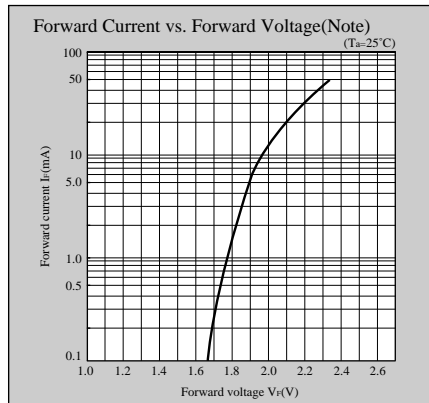
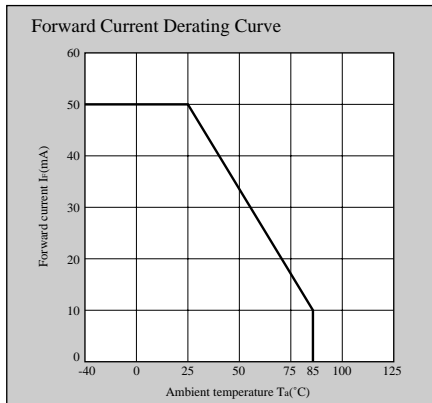

ZE series

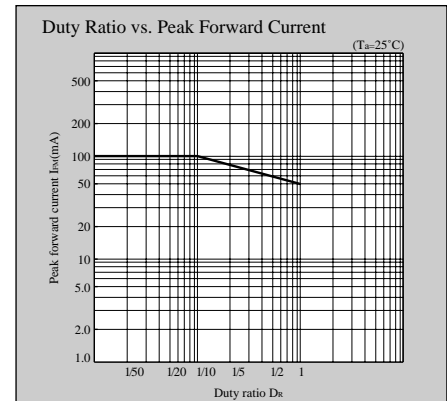
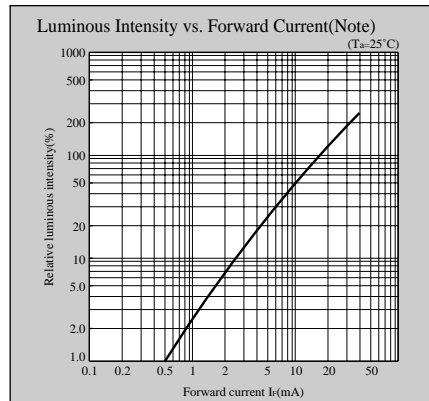
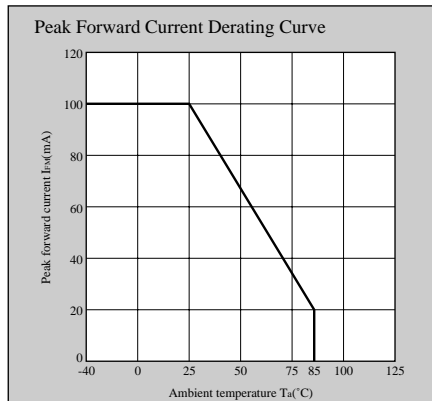
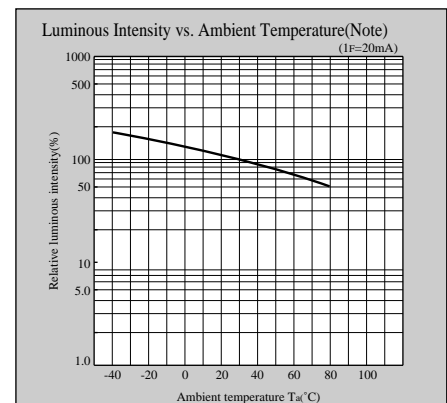
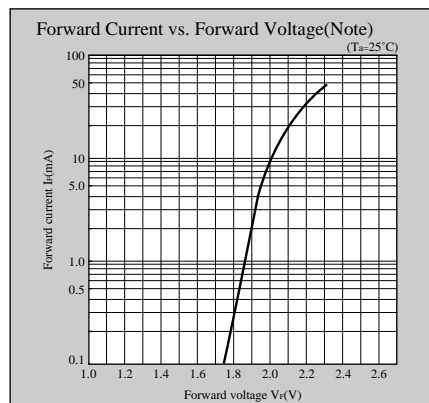
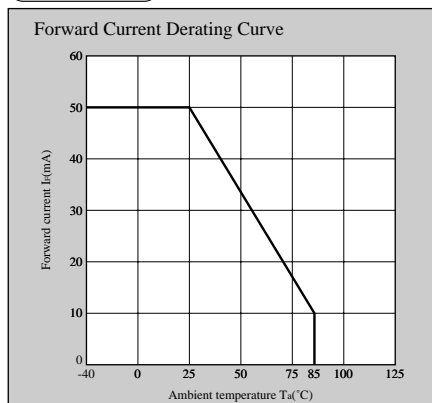

Note) Characteristics shown in diagrams are typical values. (not assurance value)

LED Lamp Characteristics Diagrams

ZG series

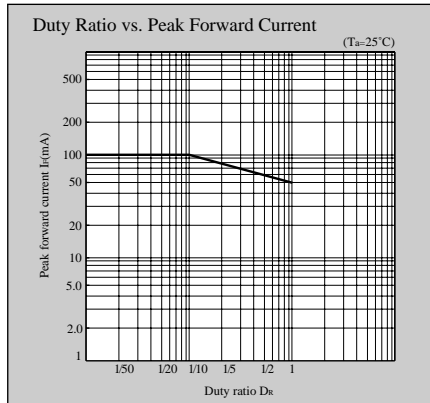
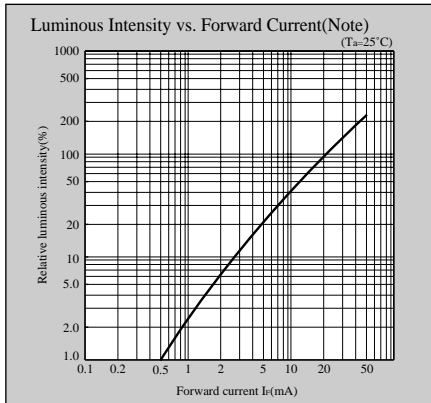
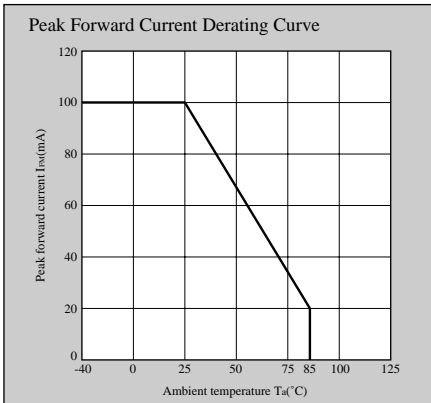
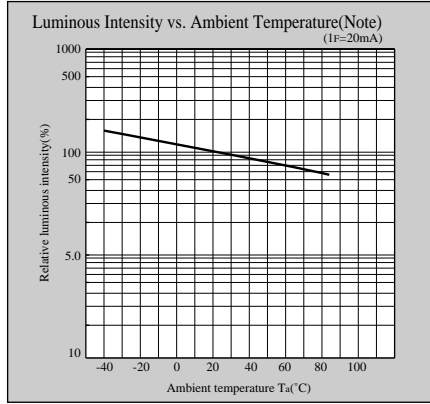
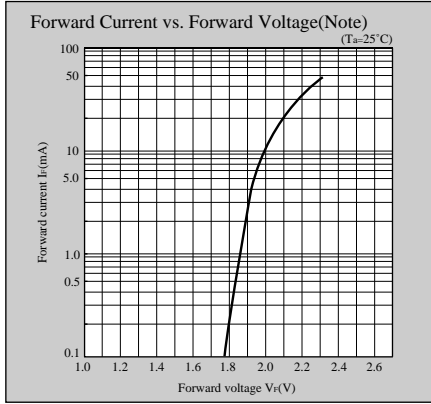
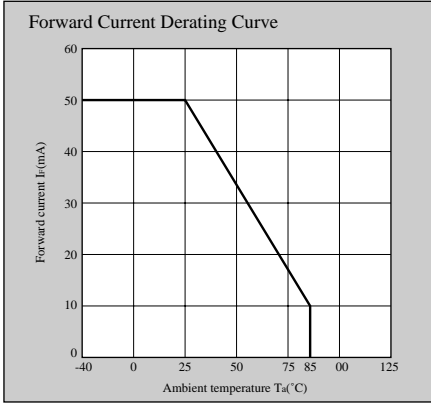

UR,U series

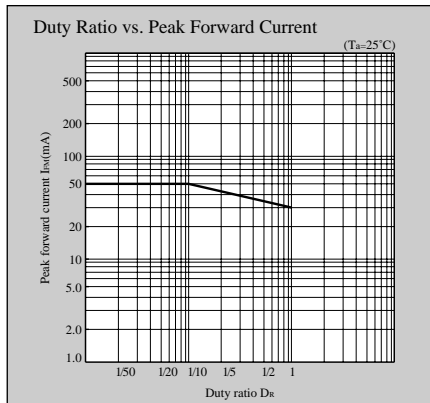
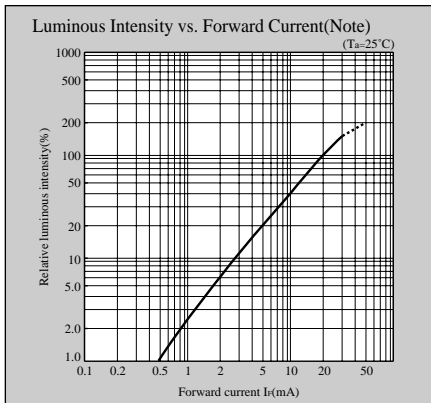
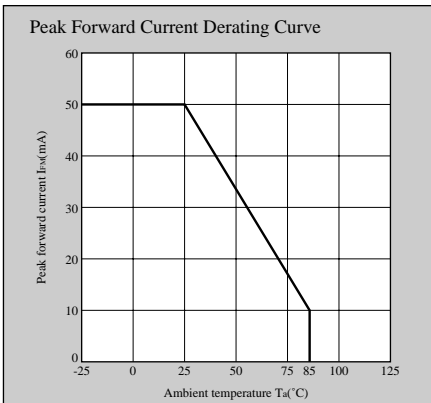
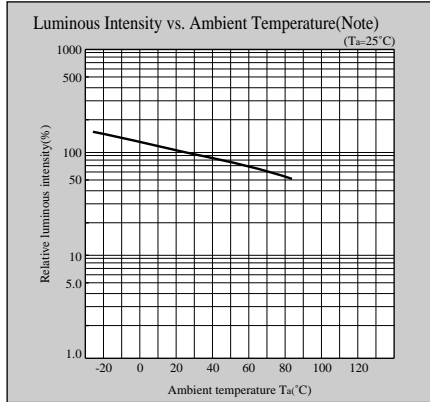
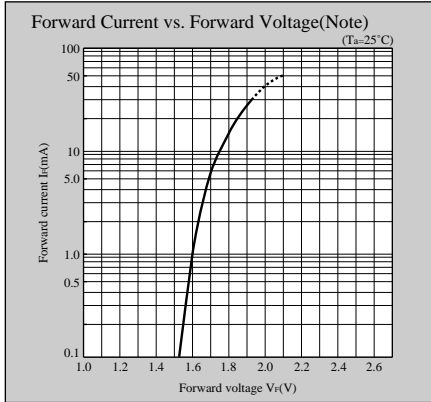
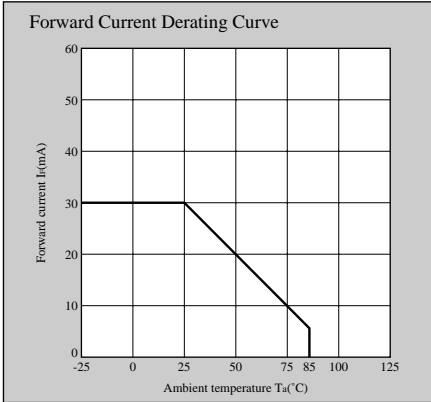

Note) Characteristics shown in diagrams are typical values. (not assurance value)

Notice In the absence of confirmation by device specification sheets, SHARP takes no responsibility for any defects that may occur in equipment using any SHARP devices shown in catalogs, data books, etc. Contact SHARP in order to obtain the latest device specification sheets before using any SHARP device.
 Internet Internet address for Electronic Components Group <http://www.sharp.co.jp/ecg/>

LED Lamp

General Description of Light Emitting Diodes

E: Chip LED Device Type

■ Mounting to a PWB

Design the product so that the devices will not be mounted in the same direction as the warp of the PWB.

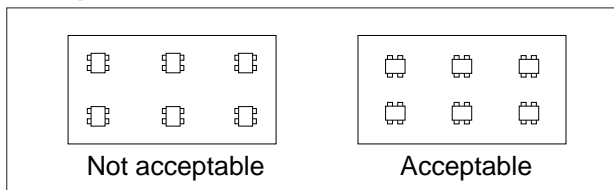

■ Soldering Conditions

Solder the lead pins under the following conditions.

Type of Soldering	Conditions
1. Manual soldering	300°C ± 5°C within 5 seconds
2. Reflow soldering	Preheating 100°C to 150°C within 2 minutes Soldering 245°C ± 5°C within 5 seconds Gradual cooling (Avoid quenching)

- In manual soldering, do not move the lead pins with the soldering edge.
- Avoid applying excessive solder reinforcement.
- In using surface mount type numeric LEDs, please refer to the specification sheet because conditions shall be changed.

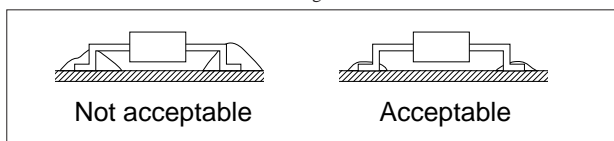

- Do not try to correct the position of the devices after soldering.
- Do not warp PWB after soldering.

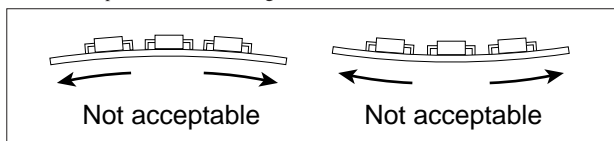

■ Cleaning

(1) Solvents

The package resin may be penetrated by solvents used in cleaning. Refer to the table below for usable solvents.

Solvent	Usable
Ethyl alcohol	○
Isopropyl alcohol	○
Chlorosen	×
Acetone	×
Trichloroethylene	×

- : Acceptable
- × : Not acceptable

(Notes) • There is a world-wide movement to restrict the use of chlorofluorocarbon (CFC) based solvents and we recommend that you avoid their use. However, before using a CFC substitute solvent, carefully check that it will not penetrate the package resin.

(2) Cleaning Methods

Cleaning Method	Usable	Remarks
Solvent cleaning	○	Immersion up to one minute at room temperature
Ultrasonic cleaning	△	Test the cleaning under actual conditions and check for abnormalities before actual use.

- : Acceptable
- △ : Acceptability depends on device type and conditions

(Notes) • The affect on the device from ultrasonic cleaning differs depending on the size of the cleaning bath, ultrasonic output, duration, board size and device mounting method. Test the cleaning method under actual conditions and check for abnormalities before actual use.

- Please contact our representative before using a cleaning solvent or method not given above.
- Since the device is very small, it may be damaged by excessive stress. So, pay special attention to the transport method and handling.

■ Leadless Chip LED(Unit : mm)

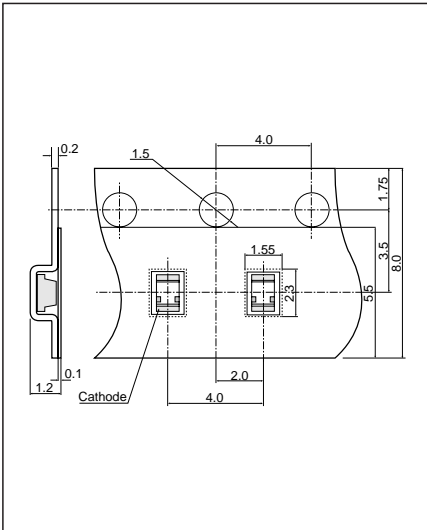

LT1□40A series 4 000 pcs. /reel

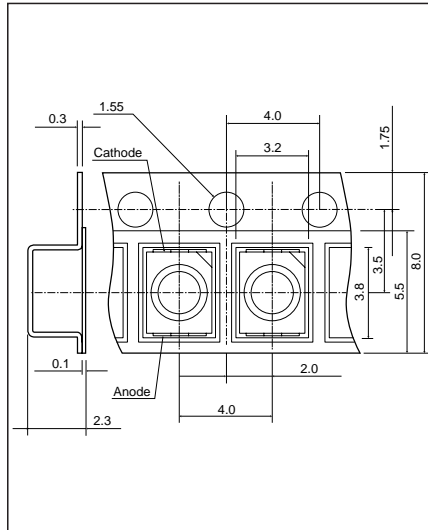

LT1Z□95 series

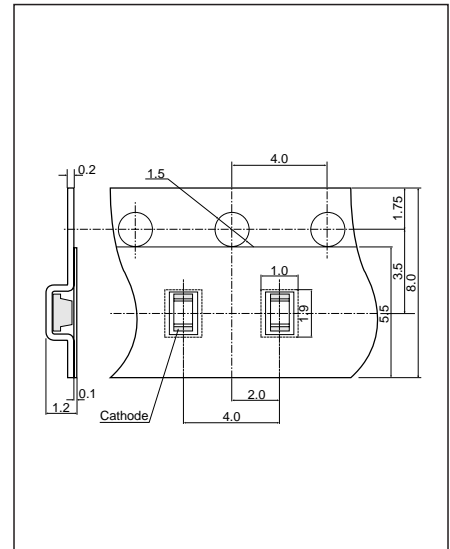

LT1□67A series 4 000 pcs. /reel

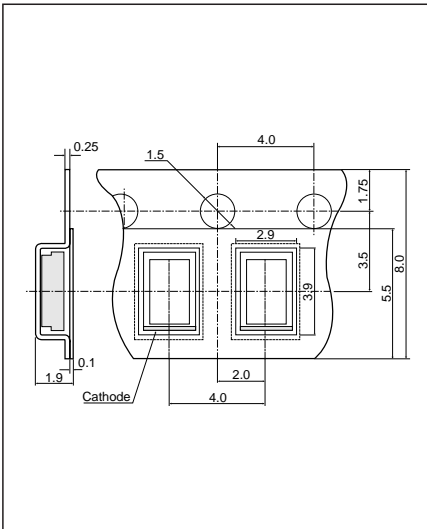

LT1□90A series 3 000 pcs. / reel

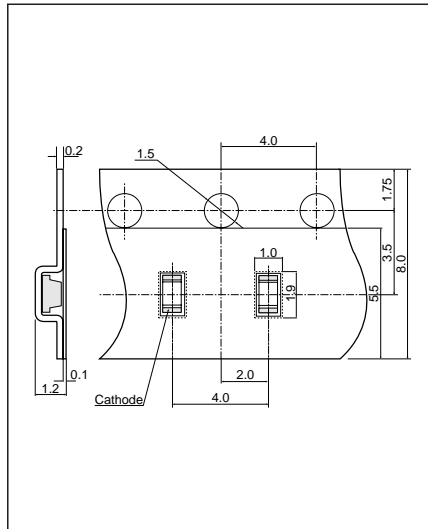

LT1□97A series 5 000 pcs. / reel

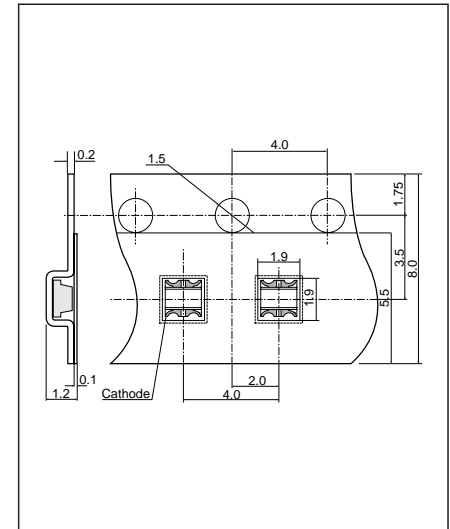

LT1□□67A series/LT1W67A 4 000 pcs. /reel

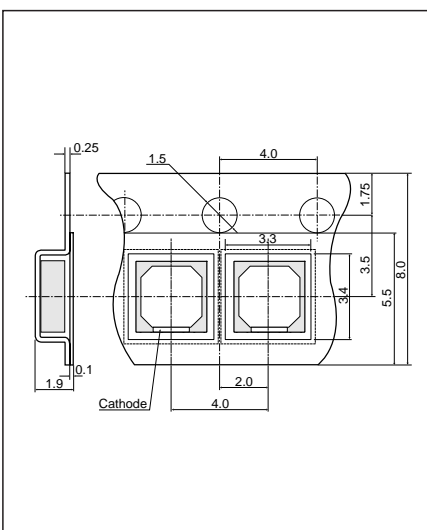

LT1□□90A series 3 000 pcs. / reel

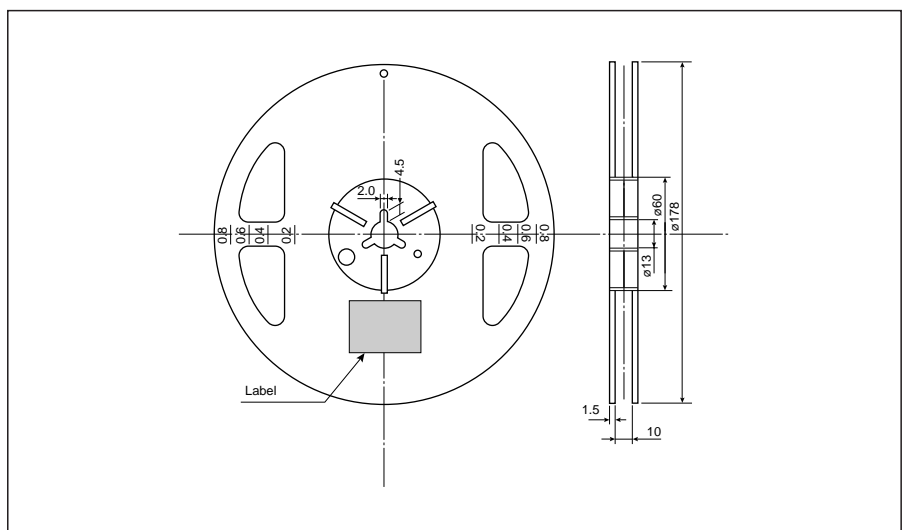

NOTICE

- The circuit application examples in this publication are provided to explain representative applications of SHARP devices and are not intended to guarantee any circuit design or license any intellectual property rights. SHARP takes no responsibility for any problems related to any intellectual property right of a third party resulting from the use of SHARP's devices.
- Contact SHARP in order to obtain the latest device specification sheets before using any SHARP device. SHARP reserves the right to make changes in the specifications, characteristics, data, materials, structure, and other contents described herein at any time without notice in order to improve design or reliability. Manufacturing locations are also subject to change without notice.
- Observe the following points when using any devices in this publication. SHARP takes no responsibility for damage caused by improper use of the devices which does not meet the conditions and absolute maximum ratings to be used specified in the relevant specification sheet nor meet the following conditions:
 - (i) The devices in this publication are designed for use in general electronic equipment designs such as:
 - Personal computers
 - Office automation equipment
 - Telecommunication equipment [terminal]
 - Test and measurement equipment
 - Industrial control
 - Audio visual equipment
 - Consumer electronics
 - (ii) Measures such as fail-safe function and redundant design should be taken to ensure reliability and safety when SHARP devices are used for or in connection with equipment that requires higher reliability such as:
 - Transportation control and safety equipment (i.e., aircraft, trains, automobiles, etc.)
 - Traffic signals
 - Gas leakage sensor breakers
 - Alarm equipment
 - Various safety devices, etc.
 - (iii) SHARP devices shall not be used for or in connection with equipment that requires an extremely high level of reliability and safety such as:
 - Space applications
 - Telecommunication equipment [trunk lines]
 - Nuclear power control equipment
 - Medical and other life support equipment (e.g., scuba).
- Contact a SHARP representative in advance when intending to use SHARP devices for any "specific" applications other than those recommended by SHARP or when it is unclear which category mentioned above controls the intended use.
- If the SHARP devices listed in this publication fall within the scope of strategic products described in the Foreign Exchange and Foreign Trade Control Law of Japan, it is necessary to obtain approval to export such SHARP devices.
- This publication is the proprietary product of SHARP and is copyrighted, with all rights reserved. Under the copyright laws, no part of this publication may be reproduced or transmitted in any form or by any means, electronic or mechanical, for any purpose, in whole or in part, without the express written permission of SHARP. Express written permission is also required before any use of this publication may be made by a third party.
- Contact and consult with a SHARP representative if there are any questions about the contents of this publication.