

Dual preamplifier with ALC detector circuit

BA3313L

The BA3313L is a dual preamplifier IC with built-in ALC detector circuit, designed for use in stereo radio cassette recorders. It comes in a compact 12-pin ZIP package, and has two record/playback preamplifiers, and an ALC detector circuit. The preamplifiers can be directly coupled to the tape head without coupling capacitors to prevent tape head magnetization and "pop" noise generation.

With the built-in ALC detector circuit, an ALC circuit with large dynamic range can be constructed with addition of just an external time constant circuit.

●Applications

Stereo radio cassette recorders

●Features

- 1) Input bias circuit does not require coupling capacitors.
- 2) Built-in ALC circuit with external time constant circuit.
- 3) Wide operating power supply voltage range.
- 4) High gain.
- 5) Low noise.

●Block diagram

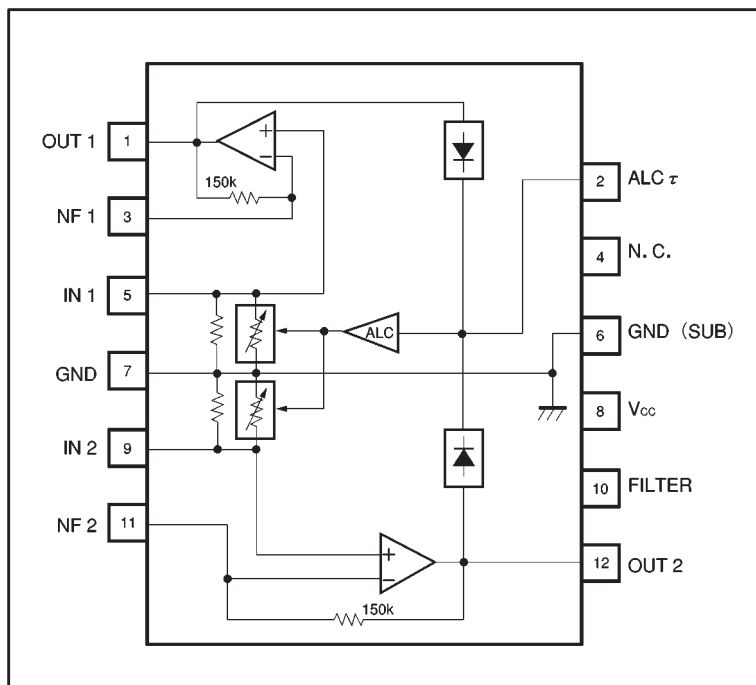

● Absolute maximum ratings (Ta = 25°C)

Parameter	Symbol	Limits	Unit
Power supply voltage	Vcc	14	V
Power dissipation	Pd	400*	mW
Operating temperature	Topr	-25~+75	°C
Storage temperature	Tstg	-55~+125	°C

* Reduced by 4.0mW for each increase in Ta of 1°C over 25°C

● Recommended operating conditions (Ta = 25°C)

Parameter	Symbol	Min.	Typ.	Max.	Unit
Power supply voltage	Vcc	5.0	8.0	12.0	V

● Electrical characteristics (unless otherwise noted, Ta = 25°C, Vcc = 8V and f = 1kHz)

Parameter	Symbol	Min.	Typ.	Max.	Unit	Conditions
Quiescent current	I _Q	1.5	3.0	6.0	mA	
Open loop voltage gain	G _{VO}	70	85	—	dB	V _O = 1V _{rms}
Closed loop voltage gain	G _{VC}	49	52	55	dB	V _O = 0.3V _{rms}
Total harmonic distortion	THD 1	—	0.3	1.0	%	V _O = 0.3V _{rms}
Maximum output voltage	V _{OM}	1.5	2.0	—	V _{rms}	THD = 1%
Input conversion-noise voltage	V _{NIN}	—	1.0	1.8	μV _{rms}	R _g = 2.2kΩ, DIN AUDIO 45dB at 1kHz NAB
Input resistance	R _{IN}	35	51	71	kΩ	
Channel separation	CS	40	55	—	dB	R _g = 2.2kΩ
ALC range *	ALC	40	53	—	dB	
ALC balance	ALB	—	0	3.0	dB	V _{IN} = -45dBV
ALC distortion	THD 2	—	0.3	1.0	%	V _{IN} = -45dBV
ALC output voltage	V _{ALC}	700	850	1000	mV _{rms}	V _{IN} = -45dBV

* The range for which the ALC begins to operate is the output voltage + 3dB with respect to the output voltage.

● Measurement circuit

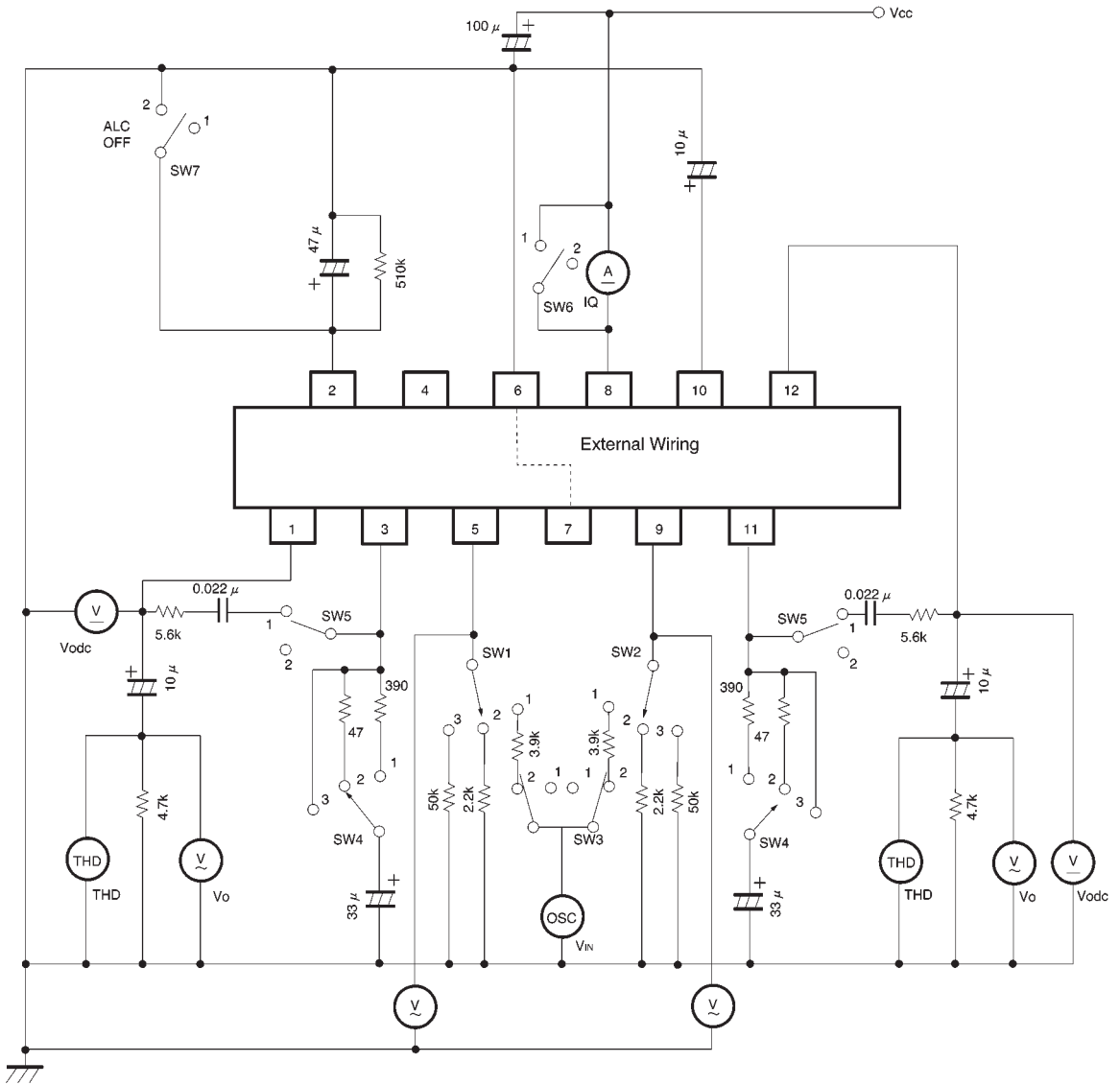

Fig. 1

Units

- Resistance : Ω (±1%)
- Film capacitors : F (±1%)
- Electrolytic capacitors : F (±5%)

●Electrical characteristics curve

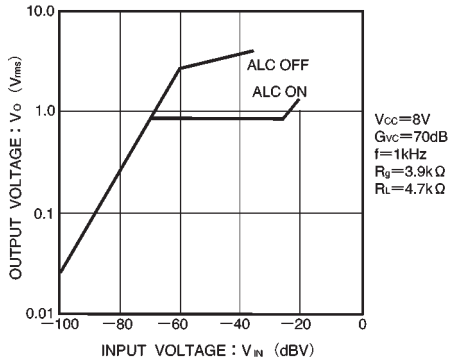

Fig. 3 Input voltage vs. output voltage

●External dimensions (Units: mm)

