

Reversible motor driver

BA6287F

The BA6287F is a reversible-motor driver with a maximum output current of 1.0A. Two logic inputs allow four output modes: forward, reverse, stop (idling), and brake. A built-in power saving circuit suppresses current consumption when the motor is in stop mode.

●Applications

VCRs and audio equipment in general

●Features

- 1) Built-in power saving circuit suppresses the stop mode current dissipation.
- 2) Output voltage can be set arbitrarily with the V_{REF} pin.
- 3) Interfaces with TTL devices.
- 4) Built-in thermal shutdown circuit.

●Absolute maximum ratings ($T_a = 25^\circ\text{C}$)

Parameter	Symbol	Limits	Unit
Power supply voltage	V_{CC}	18	V
Power dissipation	P_d	650*1	mW
Operating temperature	T_{opr}	$-20 \sim +75$	$^\circ\text{C}$
Storage temperature	T_{stg}	$-55 \sim +150$	$^\circ\text{C}$
Output current	$I_{Omax.}$	1000*2	mA

* When mounted on a glass epoxy board ($50 \times 50 \times 1.6$ mm).

* 1 Reduced by 5.2 mW for each increase in T_a 1°C over 25°C .

* 2 Should not exceed P_d or ASO values.

●Recommended operating conditions ($T_a = 25^\circ\text{C}$)

Parameter	Symbol	Min.	Typ.	Max.	Unit
Power supply voltage	V_{CC}	4.5	—	15	V
Motor power supply voltage	V_M	4.5	—	15	V
Output high level voltage setting pin	V_{REF}	4.5	—	15	V

●Block diagram

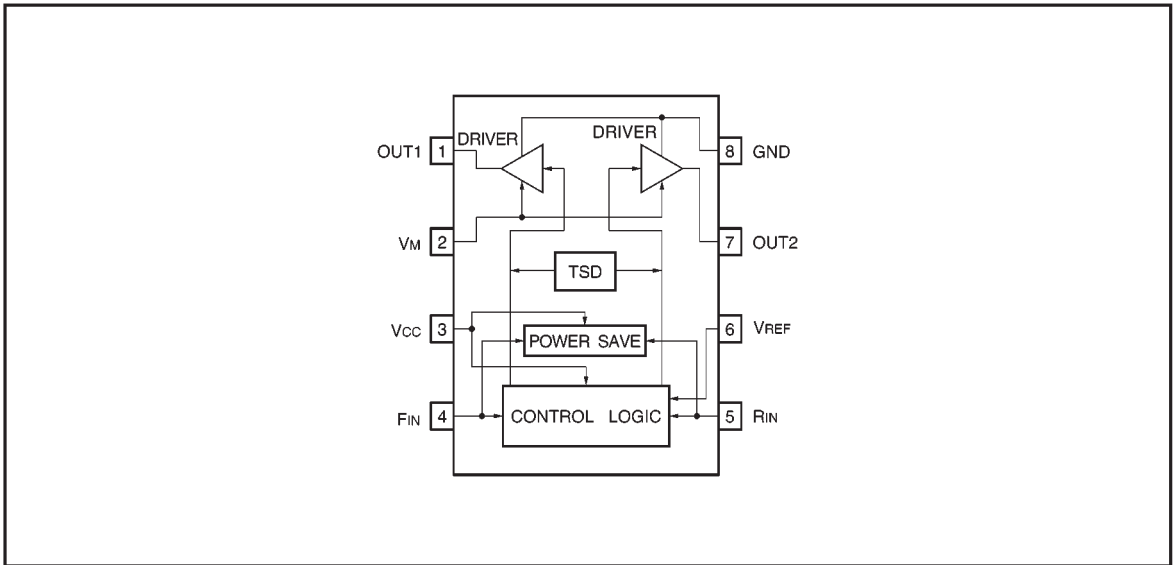

●Pin descriptions

Pin No.	Pin name	Function
1	OUT1	Motor output
2	VM	Motor power supply
3	VCC	Power supply
4	FIN	Logic input
5	RIN	Logic input
6	VREF	HIGH level output voltage setting
7	OUT2	Motor output
8	GND	GND

●Input / output circuits

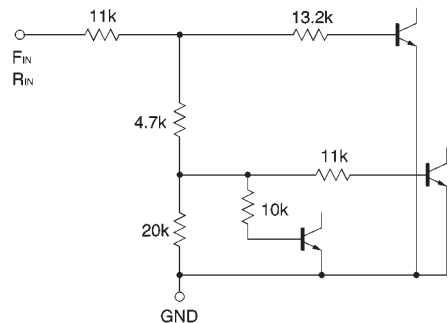
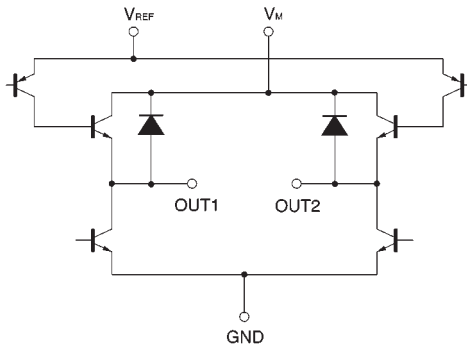

●Electrical characteristics (unless otherwise noted, Ta = 25°C, VCC = 9V, VM=9V, VREF = 9V)

Parameter	Symbol	Min.	Typ.	Max.	Unit	Conditions
Supply current 1	ICC1	12	24	36	mA	Forward or reverse mode
Supply current 2	ICC2	29	48	67	mA	Brake mode
Standby supply current	IST	—	—	15	μA	Standby mode
VREF pin sink current	IREF	6	12	18	mA	Forward or reverse mode Io=200mA
Input high level voltage	VIH	2.0	—	—	V	
Input low level voltage	VIL	—	—	0.8	V	
Input high level current	IiH	45	90	135	μA	VIN=2.0V
Output saturation voltage	VCE	—	1.0	1.5	V	Io=200mA Sum of output transistor high- and low-side voltages

●Circuit operation

(1) Input section

The four output modes are controlled by two logic inputs. Current flows from OUT1 to OUT2 when FIN is HIGH and RIN is LOW, and from OUT2 to OUT1 when RIN is HIGH and FIN is LOW (refer to the truth table). The input circuit can be operated by a logic circuit with a current capacity of 120 ~ 170μA.

Input / output truth table

FIN	RIN	OUT1	OUT2	Mode
H	L	H	L	Forward
L	H	L	H	Reverse
H	H	L	L	Brake
L	L	OPEN	OPEN	Standby

(2) Output section

Current flows from OUT1 to OUT2 during forward rotation, and from OUT2 to OUT1 during reverse rotation. The output voltages VOH and VOL are given by :

$$V_{OH} [V] = V_{REF} - V_{CE(sat)} (PNP) - V_{BE} (NPN)$$

$$V_{OL} [V] = V_{CE(sat)} (NPN)$$

VCE and VBE are functions of the output current (see electrical characteristic curves). The output current can be set with the VREF pin.

(3) Power saving circuit

All circuits are turned OFF when the FIN and RIN input pins are both put to LOW level. This circuit saves power during standby mode by leaving the outputs OPEN.

(4) Thermal shutdown circuit

When the thermal shutdown circuit is activated at the chip temperature of about 175°C (typical), the outputs are left OPEN. The temperature difference between the activation and deactivation settings is about 15°C. When the thermal shutdown circuit is deactivated, the outputs revert to the status determined by input mode.

●Application example

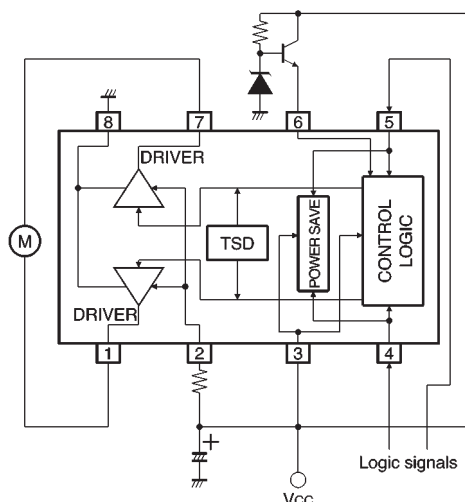

Fig.1

● Operation notes

(1) The quality of these products have been carefully checked; however, use of the products with applied voltages, operating temperatures, or other parameters that exceed the absolute maximum rating given may result in the damage of the IC and the product it is used in. If the IC is damaged, the short mode and open modes cannot be specified, so if the IC is to be used in applications where parameters may exceed the absolute maximum ratings, then be sure to incorporate fuses, or other physical safety measures.

(2) GND potential

The potential for pin 1 must be kept lower than the potentials of the other pins regardless of the circumstances.

(3) Input pins

Voltage should never be applied to the input pins when the V_{CC} voltage is not applied to the IC. Similarly, when V_{CC} is applied, the voltage on each input pin should be less than V_{CC} and within the guaranteed range for the electrical characteristics.

(4) Back-rush voltage

Depending on the ambient conditions, environment, or motor characteristics, the back-rush voltage may fluctuate. Be sure to confirm that the back-rush voltage will not adversely affect the operation of the IC.

(5) Large current line

Large currents are carried by the motor power supply and motor ground for these ICs.

Therefore, the layout of the pattern of the PC board and the constants of certain parameters for external components, such as the capacitor between the power supply and ground, may cause this large output current to flow back to the input pins, resulting in output oscillation or other malfunctions. To prevent this, make sure that the PC board layout and external circuit constants cause no problems with the characteristics of these ICs.

(6) Power dissipation

The power dissipation will fluctuate depending on the mounting conditions of the IC and the ambient environment. Make sure to carefully check the thermal design of the application where these ICs will be used.

(7) Power consumption

The power consumption by the IC varies widely with the power supply voltage and the output current. Give full consideration to the power dissipation rating and the thermal resistance data and transient thermal resistance data, to provide a thermal design so that none of the ratings for the IC are exceeded.

(8) ASO

Make sure that the output current and supply voltage do not exceed the ASO values.

(9) Precautions for input mode switching

To ensure reliability, it is recommended that the mode switching for the motor pass once through the open mode.

(10) In-rush current

There are no circuits built into these ICs that prevent in-rush currents. Therefore, it is recommended to place a current limiting resistor or other physical countermeasure.

(11) Factors regarding the thermal, power supply, and motor conditions

If the potential of the output pin sways greatly and goes below the potential of ground, the operation of the IC may malfunction or be adversely affected. In such a case, place a diode between the output and ground, or other measure, to prevent this.

(12) HIGH level output voltage setting pin

Ensure that the voltage applied to V_{REF} does not exceed the voltage on the motor power supply pin or the V_{CC} pin.

(13) The input pins have temperature-dependent characteristics. Take the temperature effect into consideration when using the IC.

(14) To eliminate motor noise, connect a capacitor between OUT1 and GND and between OUT2 and GND. Alternatively, connect a capacitor between OUT1 and OUT2, and also a diode between OUT1 and GND and between OUT2 and GND (see Fig. 2).

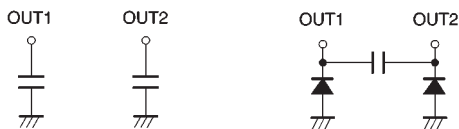

Fig.2

● Electrical characteristic curves

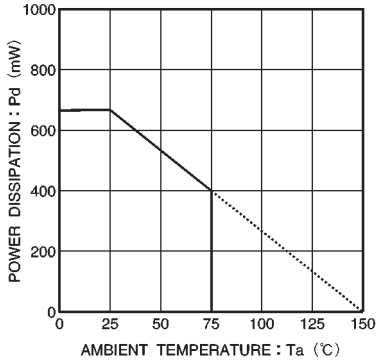

Fig.3 Thermal derating

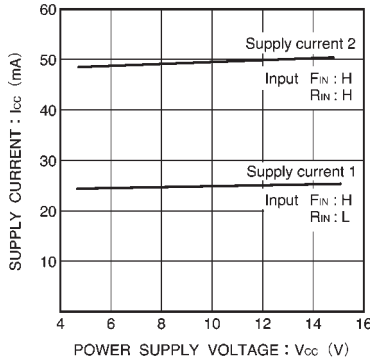

Fig.4 Supply current vs. power supply voltage

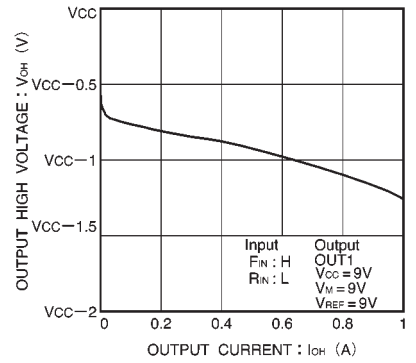

Fig.5 Output high level voltage vs. output current

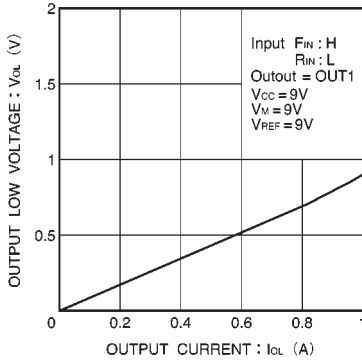

Fig.6 Output low level voltage vs. output current

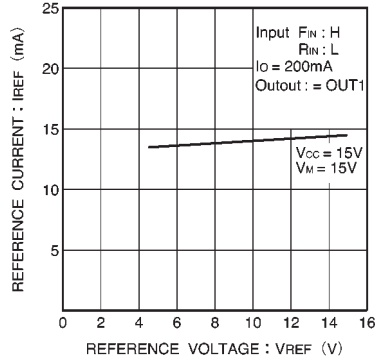

Fig.7 V_{REF} reference current vs. V_{REF} reference voltage

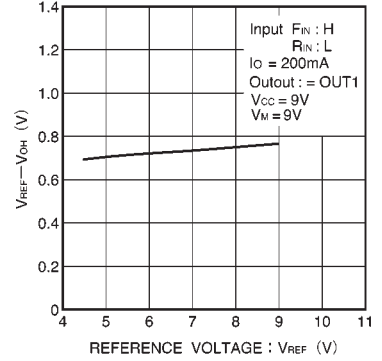

Fig.8 $V_{REF-VOH}$ voltage vs. V_{REF} reference voltage

● External dimensions (Units: mm)

