

SN74LVCC3245A

OCTAL BUS TRANSCEIVER WITH ADJUSTABLE OUTPUT VOLTAGE AND 3-STATE OUTPUTS

SCAS585L – NOVEMBER 1996 – REVISED AUGUST 2003

- Bidirectional Voltage Translator
- 2.3 V to 3.6 V on A Port and 3 V to 5.5 V on B Port
- Latch-Up Performance Exceeds 250 mA Per JESD 17
- ESD Protection Exceeds JESD 22
 - 2000-V Human-Body Model (A114-A)
 - 200-V Machine Model (A115-A)
 - 1000-V Charged-Device Model (C101)

DB, DW, NS, OR PW PACKAGE
(TOP VIEW)

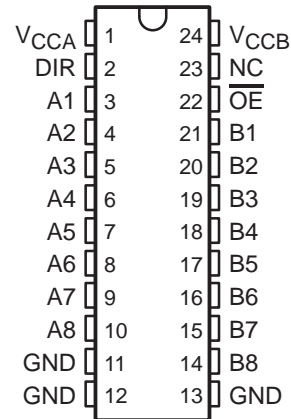

NC – No internal connection

description/ordering information

This 8-bit (octal) noninverting bus transceiver contains two separate supply rails. The B port is designed to track V_{CCB} , which accepts voltages from 3 V to 5.5 V, and the A port is designed to track V_{CCA} , which operates at 2.3 V to 3.6 V. This allows for translation from a 3.3-V to a 5-V system environment and vice versa, or from a 2.5-V to a 3.3-V system environment and vice versa.

The SN74LVCC3245A is designed for asynchronous communication between data buses. The device transmits data from the A bus to the B bus or from the B bus to the A bus, depending on the logic level at the direction-control (DIR) input. The output-enable (\overline{OE}) input can be used to disable the device so the buses are effectively isolated.

ORDERING INFORMATION

T_A	PACKAGE†		ORDERABLE PART NUMBER	TOP-SIDE MARKING
–40°C to 85°C	SOIC – DW	Tube of 25	SN74LVCC3245ADW	LVCC3245A
		Reel of 2000	SN74LVCC3245ADWR	
	SOP – NS	Reel of 2000	SN74LVCC3245ANSR	LVCC3245A
	SSOP – DB	Reel of 2000	SN74LVCC3245ADBR	LH245A
	TSSOP – PW	Tube of 60	SN74LVCC3245APW	LH245A
		Reel of 2000	SN74LVCC3245APWR	
Reel of 250		SN74LVCC3245APWT		

† Package drawings, standard packing quantities, thermal data, symbolization, and PCB design guidelines are available at www.ti.com/sc/package.

FUNCTION TABLE (each transceiver)

INPUTS		OPERATION
\overline{OE}	DIR	
L	L	B data to A bus
L	H	A data to B bus
H	X	Isolation



Please be aware that an important notice concerning availability, standard warranty, and use in critical applications of Texas Instruments semiconductor products and disclaimers thereto appears at the end of this data sheet.

PRODUCTION DATA information is current as of publication date. Products conform to specifications per the terms of Texas Instruments standard warranty. Production processing does not necessarily include testing of all parameters.

**TEXAS
INSTRUMENTS**

POST OFFICE BOX 655303 • DALLAS, TEXAS 75265

Copyright © 2003, Texas Instruments Incorporated

SN74LVCC3245A OCTAL BUS TRANSCEIVER WITH ADJUSTABLE OUTPUT VOLTAGE AND 3-STATE OUTPUTS

SCAS585L – NOVEMBER 1996 – REVISED AUGUST 2003

logic diagram (positive logic)

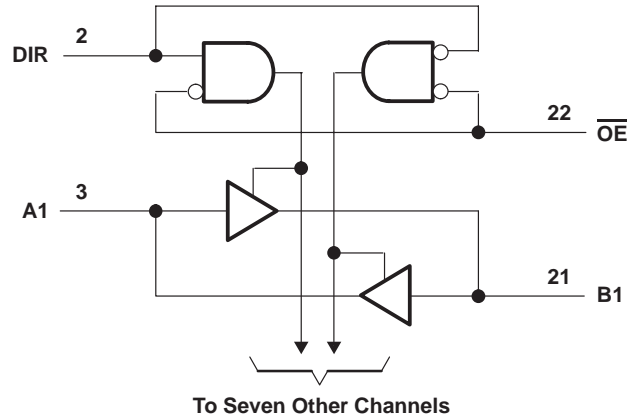

absolute maximum ratings over operating free-air temperature range (unless otherwise noted)†

Supply voltage range, V_{CCA} and V_{CCB}	-0.5 V to 6 V
Input voltage range, V_I : All A ports (see Note 1)	-0.5 V to $V_{CCA} + 0.5$ V
All B ports (see Note 2)	-0.5 V to $V_{CCB} + 0.5$ V
Except I/O ports (see Note 1)	-0.5 V to $V_{CCA} + 0.5$ V
Output voltage range, V_O (see Note 2): All A ports	-0.5 V to $V_{CCA} + 0.5$ V
All B ports	-0.5 V to $V_{CCB} + 0.5$ V
Input clamp current, I_{IK} ($V_I < 0$)	-50 mA
Output clamp current, I_{OK} ($V_O < 0$)	-50 mA
Continuous output current, I_O	± 50 mA
Continuous current through V_{CCA} , V_{CCB} , or GND	± 100 mA
Package thermal impedance, θ_{JA} (see Note 3): DB package	63°C/W
DW package	46°C/W
NS package	65°C/W
PW package	88°C/W
Storage temperature range, T_{stg}	-65°C to 150°C

† Stresses beyond those listed under “absolute maximum ratings” may cause permanent damage to the device. These are stress ratings only, and functional operation of the device at these or any other conditions beyond those indicated under “recommended operating conditions” is not implied. Exposure to absolute-maximum-rated conditions for extended periods may affect device reliability.

- NOTES: 1. This value is limited to 4.6 V maximum.
 2. This value is limited to 6 V maximum.
 3. The package thermal impedance is calculated in accordance with JESD 51-7.

SN74LVCC3245A

OCTAL BUS TRANSCEIVER WITH ADJUSTABLE OUTPUT VOLTAGE AND 3-STATE OUTPUTS

SCAS585L – NOVEMBER 1996 – REVISED AUGUST 2003

recommended operating conditions (see Note 4)

			V _{CCA}	V _{CCB}	MIN	NOM	MAX	UNIT
V _{CCA}	Supply voltage				2.3	3.3	3.6	V
V _{CCB}	Supply voltage				3	5	5.5	V
V _{IHA}	High-level input voltage	V _{OB} ≤ 0.1 V or V _{OB} ≥ V _{CCB} – 0.1 V	2.3 V	3 V	1.7			V
			2.7 V	3 V	2			
			3 V	3.6 V	2			
			3.6 V	5.5 V	2			
V _{IHB}	High-level input voltage	V _{OA} ≤ 0.1 V or V _{OA} ≥ V _{CCA} – 0.1 V	2.3 V	3 V	2			V
			2.7 V	3 V	2			
			3 V	3.6 V	2			
			3.6 V	5.5 V	3.85			
V _{ILA}	Low-level input voltage	V _{OB} ≤ 0.1 V or V _{OB} ≥ V _{CCB} – 0.1 V	2.3 V	3 V			0.7	V
			2.7 V	3 V			0.8	
			3 V	3.6 V			0.8	
			3.6 V	5.5 V			0.8	
V _{ILB}	Low-level input voltage	V _{OA} ≤ 0.1 V or V _{OA} ≥ V _{CCA} – 0.1 V	2.3 V	3 V			0.8	V
			2.7 V	3 V			0.8	
			3 V	3.6 V			0.8	
			3.6 V	5.5 V			1.65	
V _{IH}	High-level input voltage (control pins)	V _{OB} ≤ 0.1 V or V _{OB} ≥ V _{CCB} – 0.1 V	2.3 V	3 V	1.7			V
			2.7 V	3 V	2			
			3 V	3.6 V	2			
			3.6 V	5.5 V	2			
	V _{OA} ≤ 0.1 V or V _{OA} ≥ V _{CCA} – 0.1 V	2.3 V	3 V	2				
		2.7 V	3 V	2				
		3 V	3.6 V	2				
		3.6 V	5.5 V	2				
V _{IIL}	Low-level input voltage (control pins)	V _{OB} ≤ 0.1 V or V _{OB} ≥ V _{CCB} – 0.1 V	2.3 V	3 V			0.7	V
			2.7 V	3 V			0.8	
			3 V	3.6 V			0.8	
			3.6 V	5.5 V			0.8	
	V _{OA} ≤ 0.1 V or V _{OA} ≥ V _{CCA} – 0.1 V	2.3 V	3 V			0.8		
		2.7 V	3 V			0.8		
		3 V	3.6 V			0.8		
		3.6 V	5.5 V			0.8		
V _{IA}	Input voltage			0		V _{CCA}	V	
V _{IB}	Input voltage			0		V _{CCB}	V	
V _{OA}	Output voltage			0		V _{CCA}	V	
V _{OB}	Output voltage			0		V _{CCB}	V	

NOTE 4: All unused inputs of the device must be held at the associated V_{CC} or GND to ensure proper device operation. Refer to the TI application report, *Implications of Slow or Floating CMOS Inputs*, literature number SCBA004.

SN74LVCC3245A
OCTAL BUS TRANSCEIVER WITH ADJUSTABLE OUTPUT VOLTAGE
AND 3-STATE OUTPUTS

SCAS585L – NOVEMBER 1996 – REVISED AUGUST 2003

recommended operating conditions (see Note 4) (continued)

	V _{CCA}	V _{CCB}	MIN	NOM	MAX	UNIT
I _{OHA} High-level output current	2.3 V	3 V			-8	mA
	2.7 V	3 V			-12	
	3.3 V	3 V			-24	
I _{OHB} High-level output current	2.3 V	3.3 V			-12	mA
	2.7 V	3.3 V			-12	
	3.3 V	3 V			-24	
I _{OLA} Low-level output current	2.3 V	3 V			8	mA
	2.7 V	3 V			12	
	3.3 V	3 V			24	
I _{OLB} Low-level output current	2.3 V	3.3 V			12	mA
	2.7 V	3.3 V			12	
	3.3 V	3 V			24	
Δt/Δv Input transition rise or fall rate					10	ns/V
T _A Operating free-air temperature			-40		85	°C

NOTE 4: All unused inputs of the device must be held at the associated V_{CC} or GND to ensure proper device operation. Refer to the TI application report, *Implications of Slow or Floating CMOS Inputs*, literature number SCBA004.



SN74LVCC3245A

OCTAL BUS TRANSCEIVER WITH ADJUSTABLE OUTPUT VOLTAGE AND 3-STATE OUTPUTS

SCAS585L – NOVEMBER 1996 – REVISED AUGUST 2003

electrical characteristics over recommended operating free-air temperature range (unless otherwise noted)

PARAMETER		TEST CONDITIONS	V _{CCA}	V _{CCB}	MIN	TYP	MAX	UNIT
V _{OHA}		I _{OH} = -100 μA	3 V	3 V	2.9	3		V
		I _{OH} = -8 mA	2.3 V	3 V	2			
		I _{OH} = -12 mA	2.7 V	3 V	2.2	2.5		
			3 V	3 V	2.4	2.8		
		I _{OH} = -24 mA	3 V	3 V	2.2	2.6		
	2.7 V		4.5 V	2	2.3			
V _{OHB}		I _{OH} = -100 μA	3 V	3 V	2.9	3		V
		I _{OH} = -12 mA	2.3 V	3 V	2.4			
			2.7 V	3 V	2.4	2.8		
		I _{OH} = -24 mA	3 V	3 V	2.2	2.6		
	2.7 V		4.5 V	3.2	4.2			
V _{OLA}		I _{OL} = 100 μA	3 V	3 V			0.1	V
		I _{OL} = 8 mA	2.3 V	3 V			0.6	
		I _{OL} = 12 mA	2.7 V	3 V		0.1	0.5	
		I _{OL} = 24 mA	3 V	3 V		0.2	0.5	
			2.7 V	4.5 V		0.2	0.5	
V _{OLB}		I _{OL} = 100 μA	3 V	3 V			0.1	V
		I _{OL} = 12 mA	2.3 V	3 V			0.4	
			3 V	3 V		0.2	0.5	
		I _{OL} = 24 mA	3 V	4.5 V		0.2	0.5	
I _I	Control inputs	V _I = V _{CCA} or GND	3.6 V	3.6 V		±0.1	±1	μA
				5.5 V		±0.1	±1	
I _{OZ} [†]	A or B ports	V _O = V _{CCA/B} or GND, V _I = V _{IL} or V _{IH}	3.6 V	3.6 V		±0.5	±5	μA
I _{CCA}	B to A	A port = V _{CCA} or GND, I _O = 0	3.6 V	Open		5	50	μA
		B port = V _{CCB} or GND, I _O = 0	3.6 V	3.6 V		5	50	
			5.5 V			5	50	
I _{CCB}	A to B	A port = V _{CCA} or GND, I _O = 0	3.6 V	3.6 V		5	50	μA
				5.5 V		8	80	
ΔI _{CCA} [‡]	A port	V _I = V _{CCA} - 0.6 V, Other inputs at V _{CCA} or GND, OE at GND and DIR at V _{CCA}	3.6 V	3.6 V		0.35	0.5	mA
	$\overline{\text{OE}}$	V _I = V _{CCA} - 0.6 V, Other inputs at V _{CCA} or GND, DIR at V _{CCA}	3.6 V	3.6 V		0.35	0.5	
	DIR	V _I = V _{CCA} - 0.6 V, Other inputs at V _{CCA} or GND, OE at GND	3.6 V	3.6 V		0.35	0.5	
ΔI _{CCB} [‡]	B port	V _I = V _{CCB} - 2.1 V, Other inputs at V _{CCB} or GND, OE at GND and DIR at GND	3.6 V	5.5 V		1	1.5	mA
C _i	Control inputs	V _I = V _{CCA} or GND	Open	Open		4		pF
C _{io}	A or B ports	V _O = V _{CCA/B} or GND	3.3 V	5 V		18.5		pF

[†] For I/O ports, the parameter I_{OZ} includes the input leakage current.

[‡] This is the increase in supply current for each input that is at one of the specified voltage levels, rather than 0 V or the associated V_{CC}.



SN74LVCC3245A

OCTAL BUS TRANSCEIVER WITH ADJUSTABLE OUTPUT VOLTAGE AND 3-STATE OUTPUTS

SCAS585L – NOVEMBER 1996 – REVISED AUGUST 2003

switching characteristics over recommended operating free-air temperature range (unless otherwise noted) (see Figures 1 through 4)

PARAMETER	FROM (INPUT)	TO (OUTPUT)	$V_{CCA} = 2.5\text{ V} \pm 0.2\text{ V}$, $V_{CCB} = 3.3\text{ V} \pm 0.3\text{ V}$		$V_{CCA} = 2.7\text{ V TO } 3.6\text{ V}$, $V_{CCB} = 5\text{ V} \pm 0.5\text{ V}$		$V_{CCA} = 2.7\text{ V TO } 3.6\text{ V}$, $V_{CCB} = 3.3\text{ V} \pm 0.3\text{ V}$		UNIT
			MIN	MAX	MIN	MAX	MIN	MAX	
t_{PHL}	A	B	1	9.4	1	6	1	7.1	ns
t_{PLH}			1	9.1	1	5.3	1	7.2	
t_{PHL}	B	A	1	11.2	1	5.8	1	6.4	ns
t_{PLH}			1	9.9	1	7	1	7.6	
t_{PZL}	\overline{OE}	A	1	14.5	1	9.2	1	9.7	ns
t_{PZH}			1	12.9	1	9.5	1	9.5	
t_{PZL}	\overline{OE}	B	1	13	1	8.1	1	9.2	ns
t_{PZH}			1	12.8	1	8.4	1	9.9	
t_{PLZ}	\overline{OE}	A	1	7.1	1	7	1	6.6	ns
t_{PHZ}			1	6.9	1	7.8	1	6.9	
t_{PLZ}	\overline{OE}	B	1	8.8	1	7.3	1	7.5	ns
t_{PHZ}			1	8.9	1	7	1	7.9	

operating characteristics, $V_{CCA} = 3.3\text{ V}$, $V_{CCB} = 5\text{ V}$, $T_A = 25^\circ\text{C}$

PARAMETER		TEST CONDITIONS	TYP	UNIT
C_{pd}	Power dissipation capacitance per transceiver	$C_L = 50$, $f = 10\text{ MHz}$	38	pF
			4.5	

power-up considerations†

TI level-translation devices offer an opportunity for successful mixed-voltage signal design. A proper power-up sequence always should be followed to avoid excessive supply current, bus contention, oscillations, or other anomalies caused by improperly biased device pins. Take these precautions to guard against such power-up problems.

1. Connect ground before any supply voltage is applied.
2. Next, power up the control side of the device (V_{CCA} for all four of these devices).
3. Tie \overline{OE} to V_{CCA} with a pullup resistor so that it ramps with V_{CCA} .
4. Depending on the direction of the data path, DIR can be high or low. If DIR high is needed (A data to B bus), ramp it with V_{CCA} . Otherwise, keep DIR low.

† Refer to the TI application report, *Texas Instruments Voltage-Level-Translation Devices*, literature number SCEA021.



SN74LVCC3245A OCTAL BUS TRANSCEIVER WITH ADJUSTABLE OUTPUT VOLTAGE AND 3-STATE OUTPUTS

SCAS585L – NOVEMBER 1996 – REVISED AUGUST 2003

PARAMETER MEASUREMENT INFORMATION FOR A PORT $V_{CCA} = 2.5\text{ V} \pm 0.2\text{ V}$ AND $V_{CCB} = 3.3\text{ V} \pm 0.3\text{ V}$

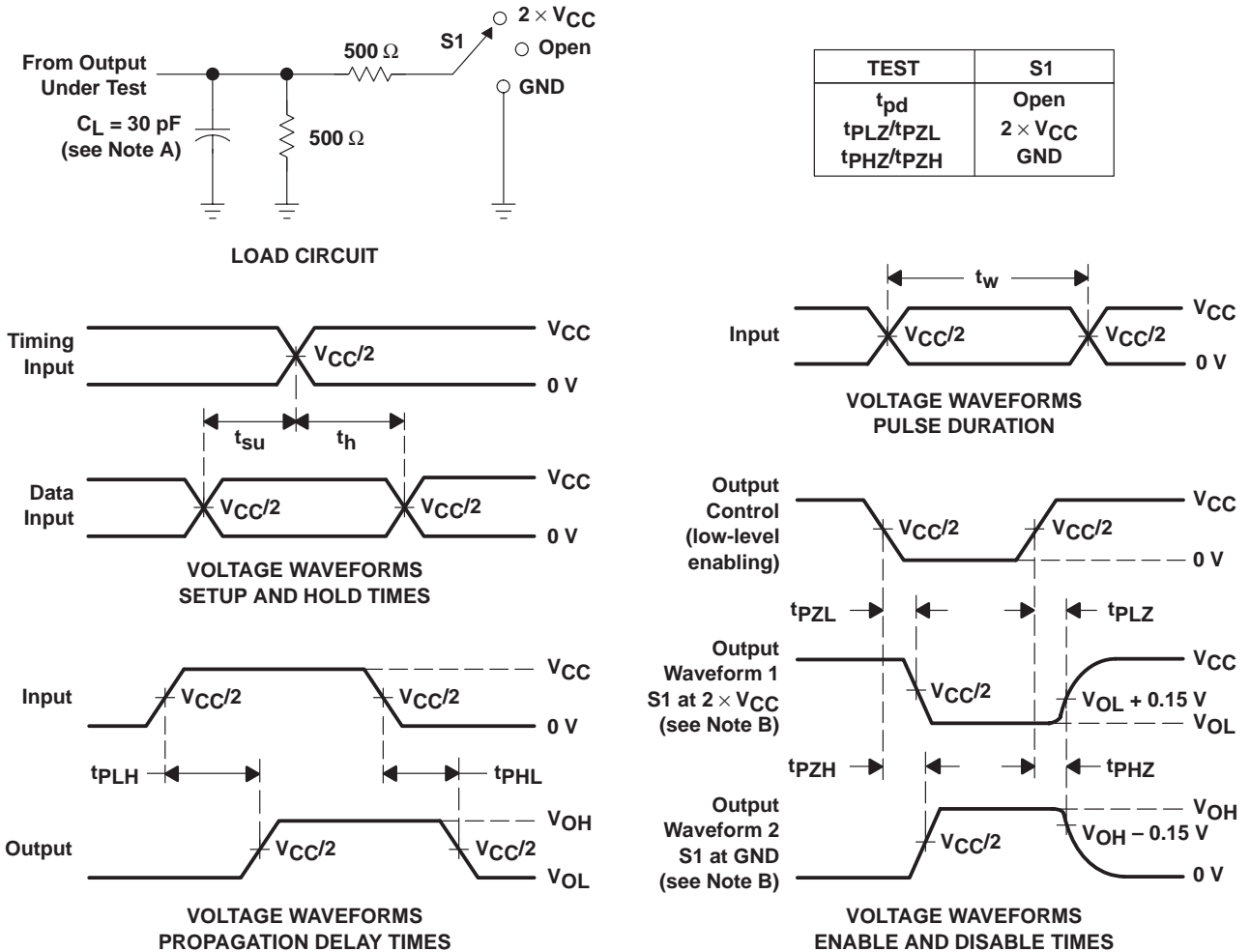

- NOTES:
- A. C_L includes probe and jig capacitance.
 - B. Waveform 1 is for an output with internal conditions such that the output is low except when disabled by the output control. Waveform 2 is for an output with internal conditions such that the output is high except when disabled by the output control.
 - C. All input pulses are supplied by generators having the following characteristics: $PRR \leq 10\text{ MHz}$, $Z_O = 50\ \Omega$, $t_r \leq 2\text{ ns}$, $t_f \leq 2\text{ ns}$.
 - D. The outputs are measured one at a time with one transition per measurement.
 - E. t_{PLZ} and t_{PHZ} are the same as t_{dis} .
 - F. t_{PZL} and t_{PZH} are the same as t_{en} .
 - G. t_{PLH} and t_{PHL} are the same as t_{pd} .
 - H. All parameters and waveforms are not applicable to all devices.

Figure 1. Load Circuit and Voltage Waveforms

SN74LVCC3245A OCTAL BUS TRANSCEIVER WITH ADJUSTABLE OUTPUT VOLTAGE AND 3-STATE OUTPUTS

SCAS585L – NOVEMBER 1996 – REVISED AUGUST 2003

PARAMETER MEASUREMENT INFORMATION FOR B PORT

$$V_{CCA} = 2.5 \text{ V} \pm 0.2 \text{ V AND } V_{CCB} = 3.3 \text{ V} \pm 0.3 \text{ V}$$

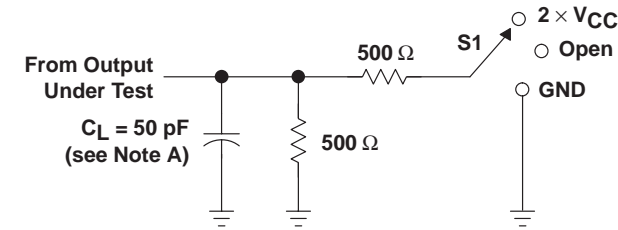

LOAD CIRCUIT

TEST	S1
t_{pd}	Open
t_{PLZ}/t_{PZL}	$2 \times V_{CC}$
t_{PHZ}/t_{PZH}	GND

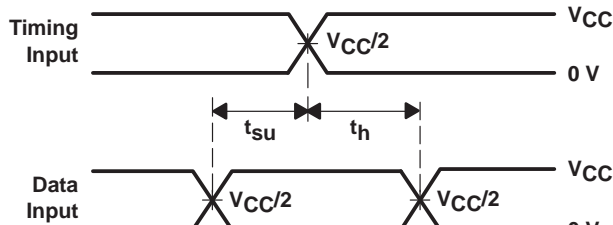

VOLTAGE WAVEFORMS
SETUP AND HOLD TIMES

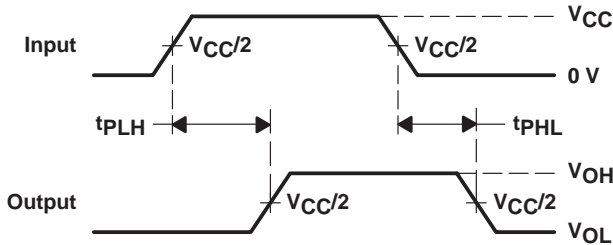

VOLTAGE WAVEFORMS
PROPAGATION DELAY TIMES

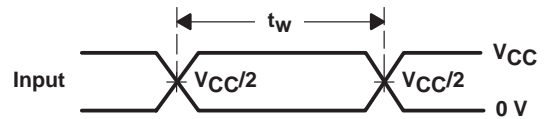

VOLTAGE WAVEFORMS
PULSE DURATION

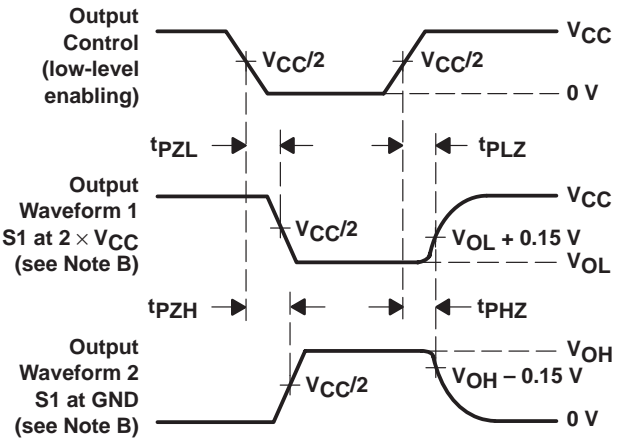

VOLTAGE WAVEFORMS
ENABLE AND DISABLE TIMES

- NOTES:
- A. C_L includes probe and jig capacitance.
 - B. Waveform 1 is for an output with internal conditions such that the output is low except when disabled by the output control. Waveform 2 is for an output with internal conditions such that the output is high except when disabled by the output control.
 - C. All input pulses are supplied by generators having the following characteristics: $PRR \leq 10 \text{ MHz}$, $Z_O = 50 \Omega$, $t_r \leq 2 \text{ ns}$, $t_f \leq 2 \text{ ns}$.
 - D. The outputs are measured one at a time with one transition per measurement.
 - E. t_{PLZ} and t_{PHZ} are the same as t_{dis} .
 - F. t_{PZL} and t_{PZH} are the same as t_{en} .
 - G. t_{PLH} and t_{PHL} are the same as t_{pd} .
 - H. All parameters and waveforms are not applicable to all devices.

Figure 2. Load Circuit and Voltage Waveforms

SN74LVCC3245A
**OCTAL BUS TRANSCEIVER WITH ADJUSTABLE OUTPUT VOLTAGE
 AND 3-STATE OUTPUTS**

SCAS585L – NOVEMBER 1996 – REVISED AUGUST 2003

PARAMETER MEASUREMENT INFORMATION FOR B PORT
 $V_{CCA} = 3.6\text{ V}$ AND $V_{CCB} = 5.5\text{ V}$

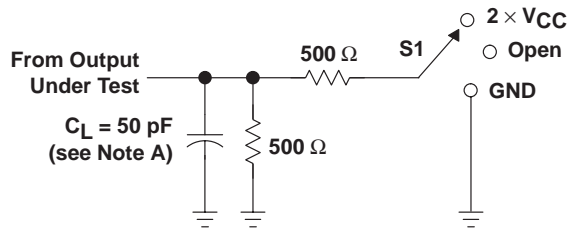

LOAD CIRCUIT

TEST	S1
t_{PLH}/t_{PHL}	Open
t_{PLZ}/t_{PZL}	$2 \times V_{CC}$
t_{PHZ}/t_{PZH}	Open

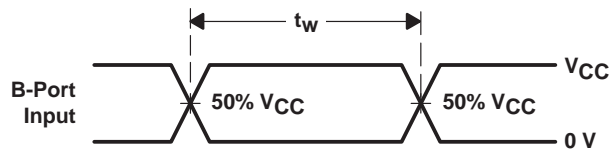

VOLTAGE WAVEFORMS
PULSE DURATION

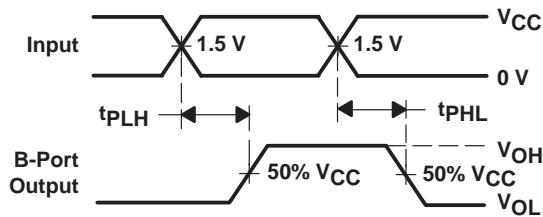

VOLTAGE WAVEFORMS
PROPAGATION DELAY TIMES
NONINVERTING OUTPUTS

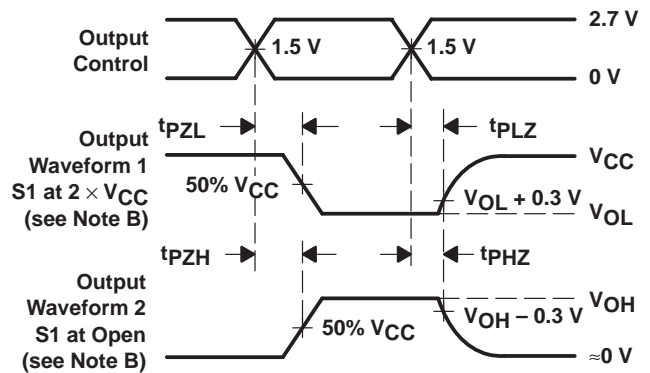

VOLTAGE WAVEFORMS
ENABLE AND DISABLE TIMES
LOW- AND HIGH-LEVEL ENABLING

- NOTES:
- C_L includes probe and jig capacitance.
 - Waveform 1 is for an output with internal conditions such that the output is low except when disabled by the output control. Waveform 2 is for an output with internal conditions such that the output is high except when disabled by the output control.
 - All input pulses are supplied by generators having the following characteristics: $PRR \leq 10\text{ MHz}$, $Z_O = 50\ \Omega$, $t_r \leq 2.5\text{ ns}$, $t_f \leq 2.5\text{ ns}$.
 - The outputs are measured one at a time with one transition per measurement.
 - All parameters and waveforms are not applicable to all devices.

Figure 3. Load Circuit and Voltage Waveforms

SN74LVCC3245A OCTAL BUS TRANSCEIVER WITH ADJUSTABLE OUTPUT VOLTAGE AND 3-STATE OUTPUTS

SCAS585L – NOVEMBER 1996 – REVISED AUGUST 2003

PARAMETER MEASUREMENT INFORMATION FOR A AND B PORT V_{CCA} AND $V_{CCB} = 3.6\text{ V}$

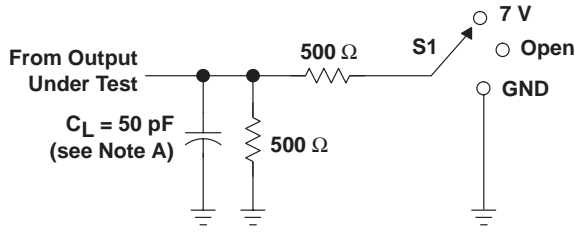

LOAD CIRCUIT

TEST	S1
t_{PLH}/t_{PHL}	Open
t_{PLZ}/t_{PZL}	7 V
t_{PHZ}/t_{PZH}	Open

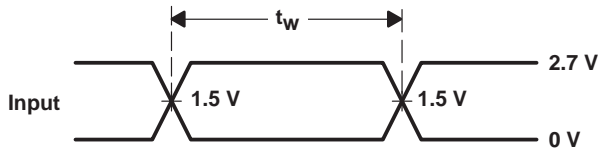

VOLTAGE WAVEFORMS
PULSE DURATION

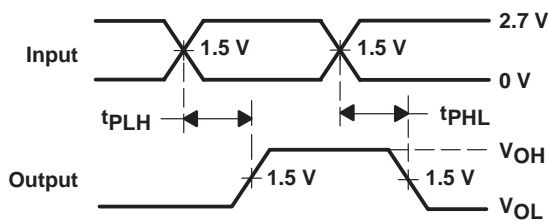

VOLTAGE WAVEFORMS
PROPAGATION DELAY TIMES
NONINVERTING OUTPUTS

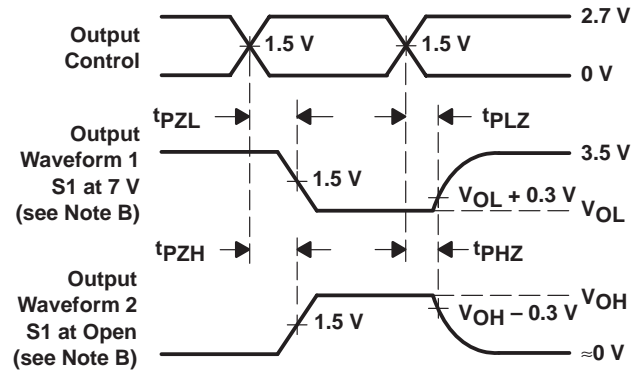

VOLTAGE WAVEFORMS
ENABLE AND DISABLE TIMES
LOW- AND HIGH-LEVEL ENABLING

- NOTES: A. C_L includes probe and jig capacitance.
 B. Waveform 1 is for an output with internal conditions such that the output is low except when disabled by the output control. Waveform 2 is for an output with internal conditions such that the output is high except when disabled by the output control.
 C. All input pulses are supplied by generators having the following characteristics: $PRR \leq 10\text{ MHz}$, $Z_O = 50\ \Omega$, $t_r \leq 2.5\text{ ns}$, $t_f \leq 2.5\text{ ns}$.
 D. The outputs are measured one at a time with one transition per measurement.
 E. All parameters and waveforms are not applicable to all devices.

Figure 4. Load Circuit and Voltage Waveforms

DW (R-PDSO-G**)

PLASTIC SMALL-OUTLINE PACKAGE

16 PINS SHOWN

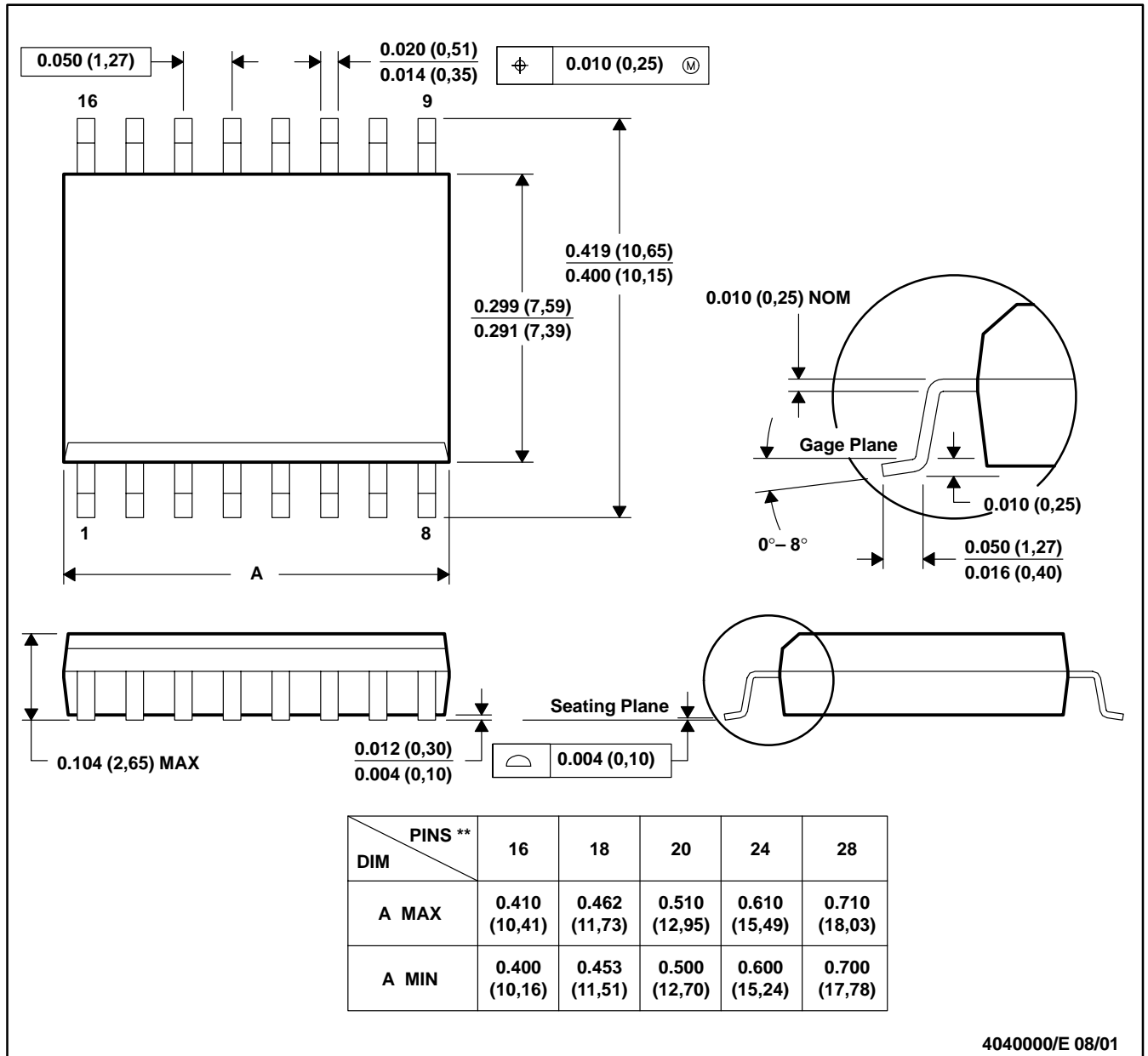

4040000/E 08/01

- NOTES: A. All linear dimensions are in inches (millimeters).
 B. This drawing is subject to change without notice.
 C. Body dimensions do not include mold flash or protrusion not to exceed 0.006 (0,15).
 D. Falls within JEDEC MS-013

MECHANICAL DATA

NS (R-PDSO-G**)

PLASTIC SMALL-OUTLINE PACKAGE

14-PINS SHOWN



- NOTES:
- A. All linear dimensions are in millimeters.
 - B. This drawing is subject to change without notice.
 - C. Body dimensions do not include mold flash or protrusion, not to exceed 0,15.

DB (R-PDSO-G**)

PLASTIC SMALL-OUTLINE

28 PINS SHOWN



- NOTES: A. All linear dimensions are in millimeters.
 B. This drawing is subject to change without notice.
 C. Body dimensions do not include mold flash or protrusion not to exceed 0,15.
 D. Falls within JEDEC MO-150

PW (R-PDSO-G**)

PLASTIC SMALL-OUTLINE PACKAGE

14 PINS SHOWN



4040064/F 01/97

- NOTES: A. All linear dimensions are in millimeters.
 B. This drawing is subject to change without notice.
 C. Body dimensions do not include mold flash or protrusion not to exceed 0,15.
 D. Falls within JEDEC MO-153

IMPORTANT NOTICE

Texas Instruments Incorporated and its subsidiaries (TI) reserve the right to make corrections, modifications, enhancements, improvements, and other changes to its products and services at any time and to discontinue any product or service without notice. Customers should obtain the latest relevant information before placing orders and should verify that such information is current and complete. All products are sold subject to TI's terms and conditions of sale supplied at the time of order acknowledgment.

TI warrants performance of its hardware products to the specifications applicable at the time of sale in accordance with TI's standard warranty. Testing and other quality control techniques are used to the extent TI deems necessary to support this warranty. Except where mandated by government requirements, testing of all parameters of each product is not necessarily performed.

TI assumes no liability for applications assistance or customer product design. Customers are responsible for their products and applications using TI components. To minimize the risks associated with customer products and applications, customers should provide adequate design and operating safeguards.

TI does not warrant or represent that any license, either express or implied, is granted under any TI patent right, copyright, mask work right, or other TI intellectual property right relating to any combination, machine, or process in which TI products or services are used. Information published by TI regarding third-party products or services does not constitute a license from TI to use such products or services or a warranty or endorsement thereof. Use of such information may require a license from a third party under the patents or other intellectual property of the third party, or a license from TI under the patents or other intellectual property of TI.

Reproduction of information in TI data books or data sheets is permissible only if reproduction is without alteration and is accompanied by all associated warranties, conditions, limitations, and notices. Reproduction of this information with alteration is an unfair and deceptive business practice. TI is not responsible or liable for such altered documentation.

Resale of TI products or services with statements different from or beyond the parameters stated by TI for that product or service voids all express and any implied warranties for the associated TI product or service and is an unfair and deceptive business practice. TI is not responsible or liable for any such statements.

Following are URLs where you can obtain information on other Texas Instruments products and application solutions:

Products		Applications	
Amplifiers	amplifier.ti.com	Audio	www.ti.com/audio
Data Converters	dataconverter.ti.com	Automotive	www.ti.com/automotive
DSP	dsp.ti.com	Broadband	www.ti.com/broadband
Interface	interface.ti.com	Digital Control	www.ti.com/digitalcontrol
Logic	logic.ti.com	Military	www.ti.com/military
Power Mgmt	power.ti.com	Optical Networking	www.ti.com/opticalnetwork
Microcontrollers	microcontroller.ti.com	Security	www.ti.com/security
		Telephony	www.ti.com/telephony
		Video & Imaging	www.ti.com/video
		Wireless	www.ti.com/wireless

Mailing Address: Texas Instruments
Post Office Box 655303 Dallas, Texas 75265

Copyright © 2003, Texas Instruments Incorporated