

# LM4670 Boomer® Audio Power Amplifier Series

## Filterless High Efficiency 3W Switching Audio Amplifier

### General Description

The LM4670 is a fully integrated single-supply high efficiency switching audio amplifier. It features an innovative modulator that eliminates the LC output filter used with typical switching amplifiers. Eliminating the output filter reduces external component count, simplifies circuit design, and reduces board area. The LM4670 processes analog inputs with a delta-sigma modulation technique that lowers output noise and THD when compared to conventional pulse width modulators.

The LM4670 is designed to meet the demands of mobile phones and other portable communication devices. Operating on a single 5V supply, it is capable of driving a 4Ω speaker load at a continuous average output of 2.3W with less than 1% THD+N. Its flexible power supply requirements allow operation from 2.4V to 5.5V.

The LM4670 has high efficiency with speaker loads compared to a typical Class AB amplifier. With a 3.6V supply driving an 8Ω speaker, the IC's efficiency for a 100mW power level is 77%, reaching 88% at 600mW output power. The LM4670 features a low-power consumption shutdown mode. Shutdown may be enabled by driving the Shutdown pin to a logic low (GND).

The gain of the LM4670 is externally configurable which allows independent gain control from multiple sources by summing the signals.

### Key Specifications

- Efficiency at 3.6V, 100mW into 8Ω speaker 77% (typ)
- Efficiency at 3.6V, 600mW into 8Ω speaker 88% (typ)
- Efficiency at 5V, 1W into 8Ω speaker 87% (typ)
- Quiescent current, 3.6V supply 4.8mA (typ)
- Total shutdown power supply current 0.01μA (typ)
- Single supply range 2.4V to 5.5V

### Features

- No output filter required for inductive loads
- Externally configurable gain
- Very fast turn on time: 1.35ms (typ)
- Minimum external components
- "Click and pop" suppression circuitry
- Micro-power shutdown mode
- Short circuit protection
- Available in space-saving microSMD and LLP packages

### Applications

- Mobile phones
- PDAs
- Portable electronic devices

### Typical Application

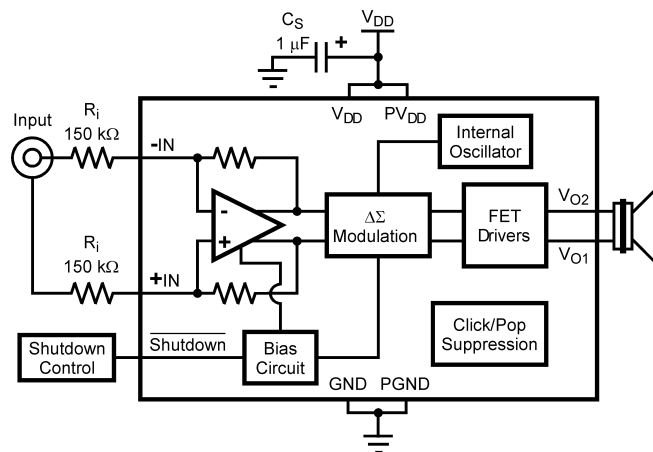

20089901

FIGURE 1. Typical Audio Amplifier Application Circuit

## Connection Diagrams

9 Bump micro SMD Package

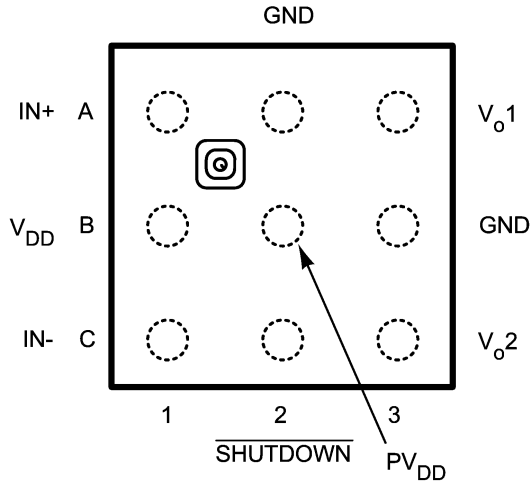

20089936

**Top View**  
 Order Number LM4670ITL, LM4670ITLX  
 See NS Package Number TLA09ZZA

Leadless Leadframe Package (LLP)

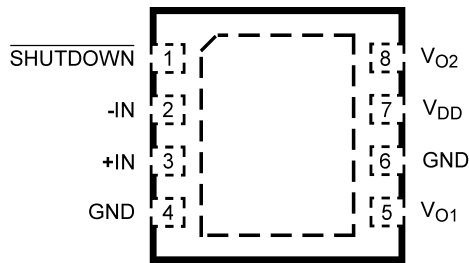

20089949

**Top View**  
 Order Number LM4670SD  
 See NS Package Number SDA08A  
 Contact NSC Sales Office for Availability

micro SMD Marking

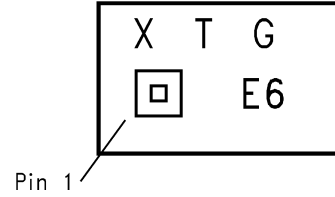

200899C6

**Top View**  
 X — Date Code  
 T — Die Traceability  
 G — Boomer Family  
 E6 — LM4670ITL

LLP Marking

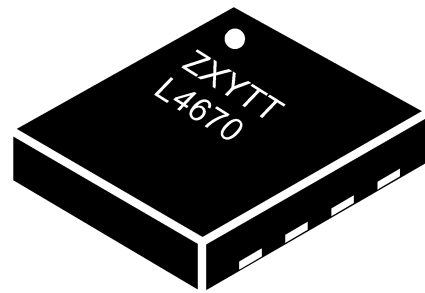

20089950

**Top View**  
 Z — Plant Code  
 XY — Date Code  
 TT — Die Traceability  
 L4670 — LM4670

**Absolute Maximum Ratings** (Notes 1, 2)

If Military/Aerospace specified devices are required, please contact the National Semiconductor Sales Office/Distributors for availability and specifications.

Supply Voltage (Note 1)	6.0V
Storage Temperature	-65°C to +150°C
Voltage at Any Input Pin	$V_{DD} + 0.3V \geq V \geq GND - 0.3V$
Power Dissipation (Note 3)	Internally Limited
ESD Susceptibility (Note 4)	2.0kV
ESD Susceptibility (Note 5)	200V
Junction Temperature ( $T_{JMAX}$ )	150°C
Thermal Resistance	

$\theta_{JA}$ (micro SMD)	220°C/W
$\theta_{JA}$ (LLP)	64°C/W
$\theta_{JC}$ (LLP)	TBD°C/W

**Soldering Information**

See AN-1112 "microSMD Wafers Level Chip Scale Package."

**Operating Ratings** (Note 1) (Note 2)

Temperature Range	$-40^{\circ}\text{C} \leq T_A \leq 85^{\circ}\text{C}$
Supply Voltage	$2.4\text{V} \leq V_{DD} \leq 5.5\text{V}$

**Electrical Characteristics** (Notes 1, 2)

The following specifications apply for  $A_V = 2V/V$  ( $R_I = 150\text{k}\Omega$ ),  $R_L = 15\mu\text{H} + 8\Omega + 15\mu\text{H}$  unless otherwise specified. Limits apply for  $T_A = 25^{\circ}\text{C}$ .

Symbol	Parameter	Conditions	LM4670		Units (Limits)
			Typical	Limit	
			(Note 6)	(Notes 7, 8)	
$ V_{OS} $	Differential Output Offset Voltage	$V_I = 0V, A_V = 2V/V,$ $V_{DD} = 2.4V$ to $5.0V$		25	mV (max)
$PSRR_{GSM}$	GSM Power Supply Rejection Ratio	$V_{DD} = 2.4V$ to $5.0V,$ Input Referred	64		dB
$CMRR_{GSM}$	GSM Common Mode Rejection Ratio	$V_{DD} = 2.4V$ to $5.0V$ $V_{IC} = V_{DD}/2$ to $0.5V,$ $V_{IC} = V_{DD}/2$ to $V_{DD} - 0.8V,$ Input Referred	80		dB
$ I_{IH} $	Logic High Input Current	$V_{DD} = 5.0V, V_I = 5.8V$	20	100	$\mu\text{A}$ (max)
$ I_{IL} $	Logic Low Input Current	$V_{DD} = 5.0V, V_I = -0.3V$	1	5	$\mu\text{A}$ (max)
$I_{DD}$	Quiescent Power Supply Current	$V_{IN} = 0V,$ No Load, $V_{DD} = 5.0V$	7.0	10	mA (max)
		$V_{IN} = 0V,$ No Load, $V_{DD} = 3.6V$	4.8		mA
		$V_{IN} = 0V,$ No Load, $V_{DD} = 2.4V$	3.8	5	mA (max)
$I_{SD}$	Shutdown Current	$V_{SHUTDOWN} = 0V$ $V_{DD} = 2.4V$ to $5.0V$	0.01	1	$\mu\text{A}$ (max)
$V_{SDIH}$	Shutdown voltage input high		1.0	1.4	V (min)
$V_{SDIL}$	Shutdown voltage input low		0.8	0.4	V (max)
$R_{OSD}$	Output Impedance	$V_{SHUTDOWN} = 0.4V$	>100		k $\Omega$
$A_V$	Gain		$300\text{k}\Omega/R_I$	$270\text{k}\Omega/R_I$ $330\text{k}\Omega/R_I$	V/V (min) V/V (max)
$R_{SD}$	Resistance from Shutdown Pin to GND		300		k $\Omega$
$P_O$	Output Power	$R_L = 15\mu\text{H} + 4\Omega + 15\mu\text{H},$ THD = 10% (max) $f = 1\text{kHz}, 22\text{kHz BW}$ $V_{DD} = 5V$ $V_{DD} = 3.6V$ $V_{DD} = 2.5V$	3.0		W
			1.5		W
			675		mW
		$R_L = 15\mu\text{H} + 4\Omega + 15\mu\text{H},$ THD+N = 1% (max) $f = 1\text{kHz}, 22\text{kHz BW}$ $V_{DD} = 5V,$ $V_{DD} = 3.6V,$ $V_{DD} = 2.5V,$	2.3		W
			1.2		W
			550		mW

## Electrical Characteristics (Notes 1, 2)

The following specifications apply for  $A_V = 2V/V$  ( $R_L = 150k\Omega$ ),  $R_L = 15\mu H + 8\Omega + 15\mu H$  unless otherwise specified. Limits apply for  $T_A = 25^\circ C$ . (Continued)

Symbol	Parameter	Conditions	LM4670		Units (Limits)
			Typical	Limit	
			(Note 6)	(Notes 7, 8)	
$P_O$	Output Power	$R_L = 15\mu H + 8\Omega + 15\mu H$ , THD = 10% (max) $f = 1\text{kHz}$ , 22kHz BW $V_{DD} = 5V$ $V_{DD} = 3.6V$ $V_{DD} = 2.5V$	1.65 850 400		W mW mW
		$R_L = 15\mu H + 8\Omega + 15\mu H$ , THD+N = 1% (max) $f = 1\text{kHz}$ , 22kHz BW $V_{DD} = 5V$ , $V_{DD} = 3.6V$ , $V_{DD} = 2.5V$ ,	1.35 680 325	600	W mW (min) mW
THD+N	Total Harmonic Distortion + Noise	$V_{DD} = 5V$ , $P_O = 1W_{RMS}$ , $f = 1\text{kHz}$	0.35		%
		$V_{DD} = 3.6V$ , $P_O = 0.5W_{RMS}$ , $f = 1\text{kHz}$	0.30		%
		$V_{DD} = 3.6V$ , $P_O = 0.5W_{RMS}$ , $f = 5\text{kHz}$	0.30		%
		$V_{DD} = 3.6V$ , $P_O = 0.5W_{RMS}$ , $f = 10\text{kHz}$	0.30		%
PSRR	Power Supply Rejection Ratio	$V_{DD} = 3.6V$ , $V_{Ripple} = 200mV_{PP}$ Sine, $f_{Ripple} = 217\text{Hz}$ Inputs to AC GND, $C_1 = 0.1\mu$ , Input Referred	68		dB
		$V_{DD} = 3.6V$ , $V_{Ripple} = 200mV_{PP}$ Sine, $f_{Ripple} = 1\text{kHz}$ Inputs to AC GND, $C_1 = 0.1\mu F$ Input Referred	65		dB
		$V_{DD} = 3.6V$ , $V_{Ripple} = 200mV_{PP}$ Sine, $f_{Ripple} = 217\text{Hz}$ $f_{IN} = 1\text{kHz}$ , $P_O = 10mW_{RMS}$ Input Referred	62		dB
SNR	Signal to Noise Ratio	$V_{DD} = 5V$ , $P_O = 1W_{RMS}$	93		dB
$\epsilon_{OUT}$	Output Noise	$V_{DD} = 3.6V$ , $f = 20\text{Hz} - 20\text{kHz}$ Inputs to AC GND, $C_1 = 0.1\mu F$ No Weighting, Input Referred	85		$\mu V_{RMS}$
		$V_{DD} = 3.6V$ , Inputs to AC GND $C_1 = 0.1\mu F$ , A Weighted Input Referred	65		$\mu V_{RMS}$
CMRR	Common Mode Rejection Ratio	$V_{DD} = 3.6V$ , $V_{Ripple} = 1V_{PP}$ Sine $f_{Ripple} = 217\text{Hz}$ , Input Referred	80		dB
$T_{WU}$	Wake-up Time	$V_{DD} = 3.6V$	1.35		ms
$T_{SD}$	Shutdown Time	$V_{DD} = 3.6V$	0.01		ms

**Note 1:** All voltages are measured with respect to the ground pin, unless otherwise specified.

**Note 2:** *Absolute Maximum Ratings* indicate limits beyond which damage to the device may occur. *Operating Ratings* indicate conditions for which the device is functional, but do not guarantee specific performance limits. *Electrical Characteristics* state DC and AC electrical specifications under particular test conditions which

guarantee specific performance limits. This assumes that the device is within the Operating Ratings. Specifications are not guaranteed for parameters where no limit is given, however, the typical value is a good indication of device performance.

**Note 3:** The maximum power dissipation must be derated at elevated temperatures and is dictated by  $T_{JMAX}$ ,  $\theta_{JA}$ , and the ambient temperature  $T_A$ . The maximum allowable power dissipation is  $P_{DMAX} = (T_{JMAX} - T_A) / \theta_{JA}$  or the number given in Absolute Maximum Ratings, whichever is lower. For the LM4670,  $T_{JMAX} = 150^\circ\text{C}$ . The typical  $\theta_{JA}$  is  $220^\circ\text{C/W}$  for the microSMD package and  $64^\circ\text{C/W}$  for the LLP package.

**Note 4:** Human body model, 100pF discharged through a  $1.5\text{k}\Omega$  resistor.

**Note 5:** Machine Model, 220pF–240pF discharged through all pins.

**Note 6:** Typical specifications are specified at  $25^\circ\text{C}$  and represent the parametric norm.

**Note 7:** Tested limits are guaranteed to National's AOQL (Average Outgoing Quality Level).

**Note 8:** Datasheet min/max specification limits are guaranteed by design, test, or statistical analysis.

**Note 9:** Shutdown current is measured in a normal room environment. Exposure to direct sunlight will increase  $I_{SD}$  by a maximum of  $2\mu\text{A}$ . The Shutdown pin should be driven as close as possible to GND for minimal shutdown current and to  $V_{DD}$  for the best THD performance in PLAY mode. See the **Application Information** section under SHUTDOWN FUNCTION for more information.

**Note 10:** The performance graphs were taken using the Audio Precision AUX-0025 Switching Amplifier Measurement Filter in series with the LC filter on the board.

## External Components Description

(Figure 1)

Components		Functional Description
1.	$C_S$	Supply bypass capacitor which provides power supply filtering. Refer to the <b>Power Supply Bypassing</b> section for information concerning proper placement and selection of the supply bypass capacitor.
2.	$R_I$	Gain setting resistor. Differential gain is set by the equation $A_V = 2 * 150\text{k}\Omega / R_I(\text{V/V})$ .

## Typical Performance Characteristics (Note 10)

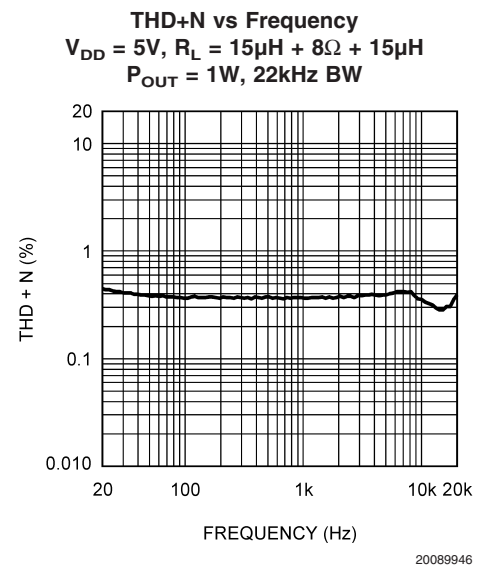
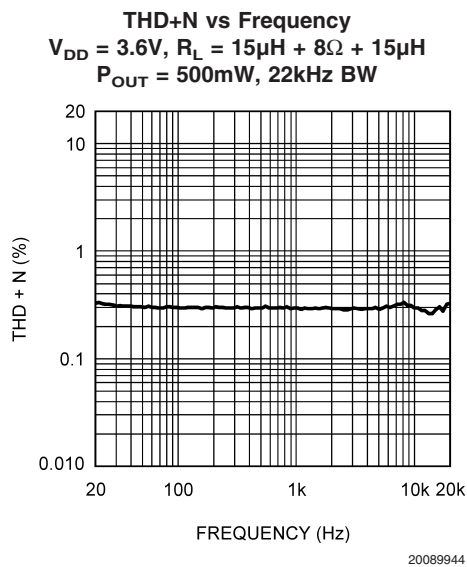
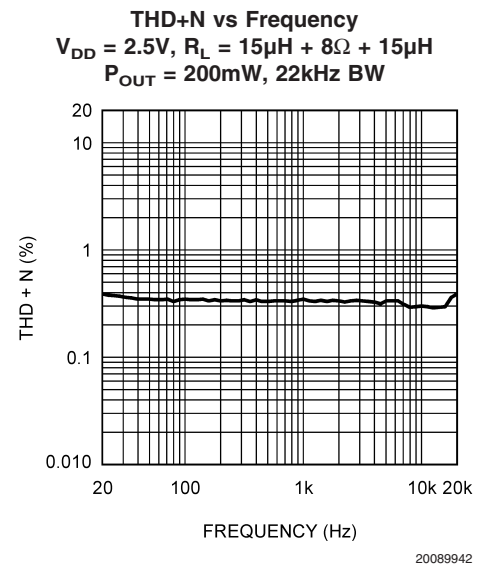
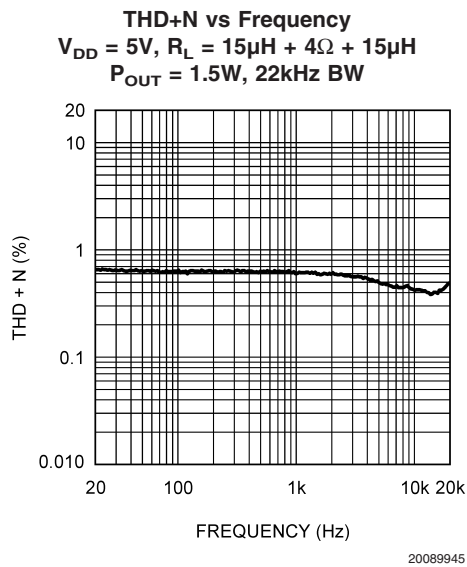
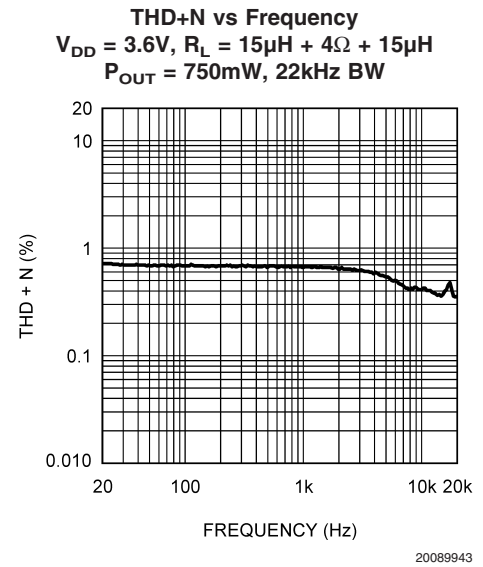
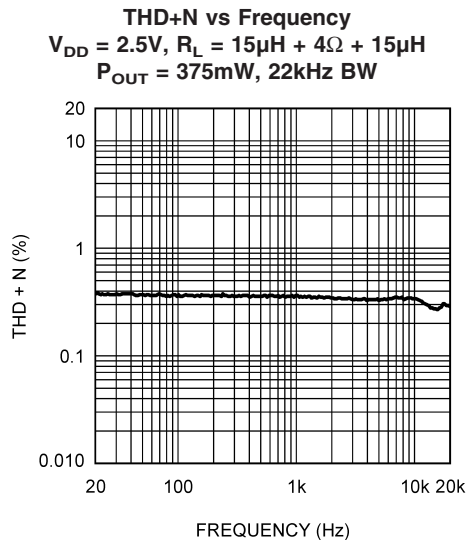

Typical Performance Characteristics (Note 10) (Continued)

THD+N vs Output Power

$R_L = 15\mu H + 4\Omega + 15\mu H$   
 $f = 1\text{kHz}, 22\text{kHz BW}$

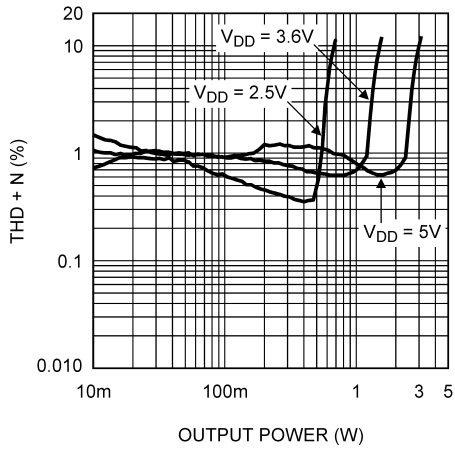

20089947

THD+N vs Output Power

$R_L = 15\mu H + 8\Omega + 15\mu H$   
 $f = 1\text{kHz}, 22\text{kHz BW}$

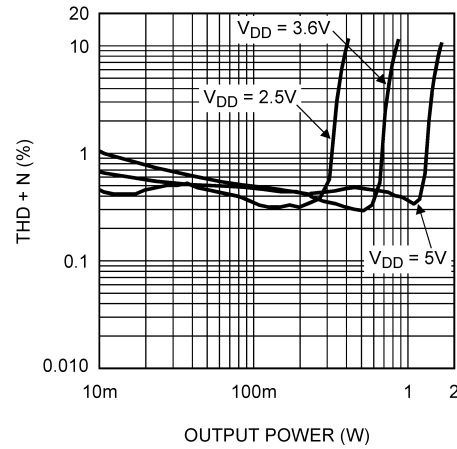

20089948

CMRR vs Frequency

$V_{DD} = 3.6\text{V}, R_L = 15\mu H + 8\Omega + 15\mu H$   
 $V_{CM} = 1V_{P-P}$  Sine Wave, 22kHz BW

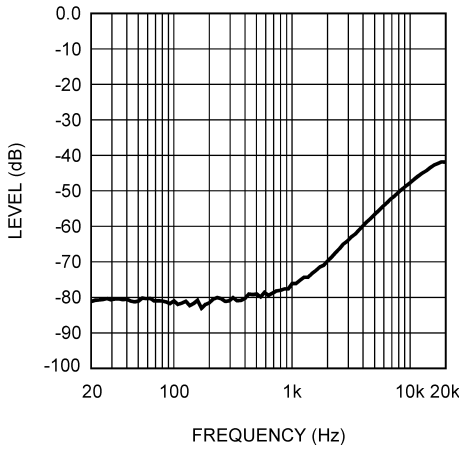

20089910

PSRR vs Frequency

$V_{DD} = 3.6\text{V}, R_L = 15\mu H + 8\Omega + 15\mu H$   
 $V_{CM} = 200mV_{P-P}$  Sine Wave, 22kHz BW

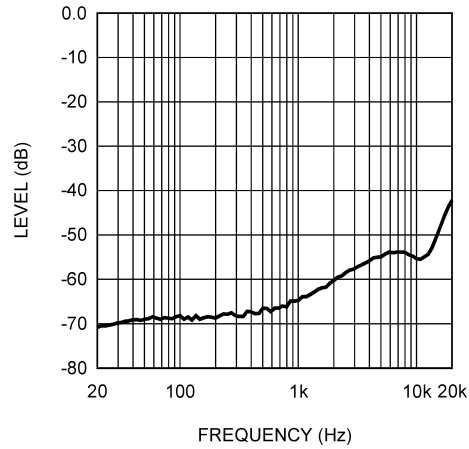

20089940

Efficiency and Power Dissipation vs Output Power

$R_L = 15\mu H + 4\Omega + 15\mu H, f = 1\text{kHz}, \text{THD} < 2\%$

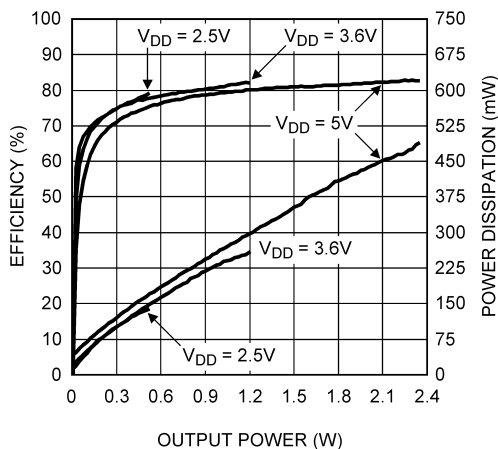

20089911

Efficiency and Power Dissipation vs Output Power

$R_L = 15\mu H + 8\Omega + 15\mu H, f = 1\text{kHz}, \text{THD} < 1\%$

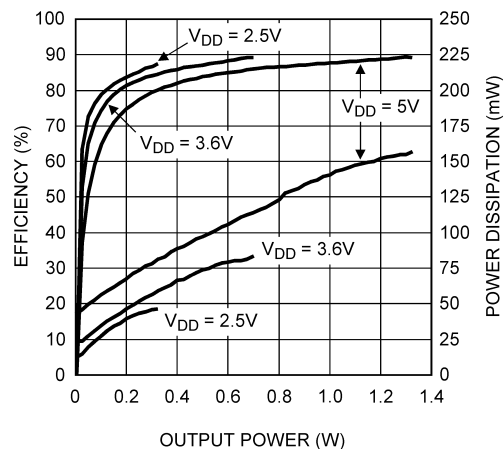

20089912

Typical Performance Characteristics (Note 10) (Continued)

**Output Power vs Supply Voltage**  
 $R_L = 15\mu H + 4\Omega + 15\mu H, f = 1kHz, 22kHz BW$

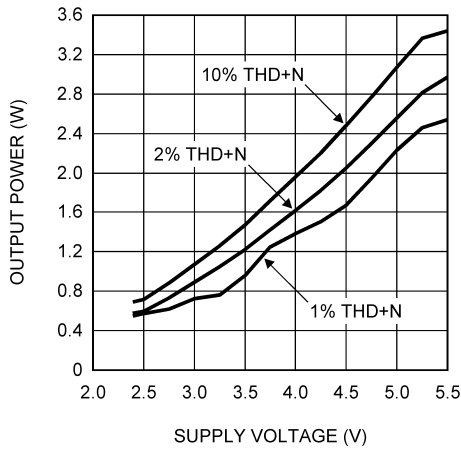

20089914

**Output Power vs Supply Voltage**  
 $R_L = 15\mu H + 8\Omega + 15\mu H, f = 1kHz, 22kHz BW$

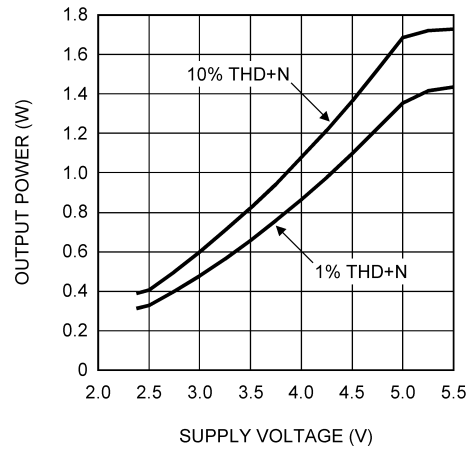

20089915

**Supply Current (RMS) vs Output Power**  
 $R_L = 15\mu H + 4\Omega + 15\mu H, f = 1kHz$

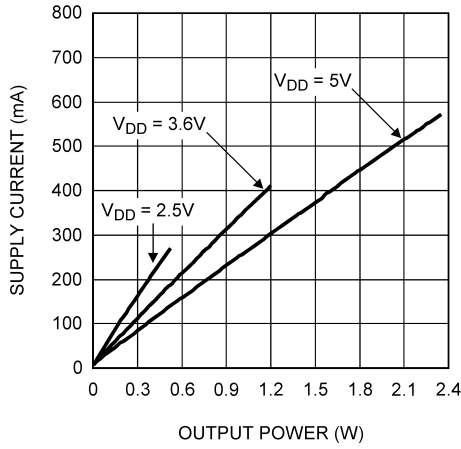

20089919

**Supply Current (RMS) vs Output Power**  
 $R_L = 15\mu H + 8\Omega + 15\mu H, f = 1kHz$

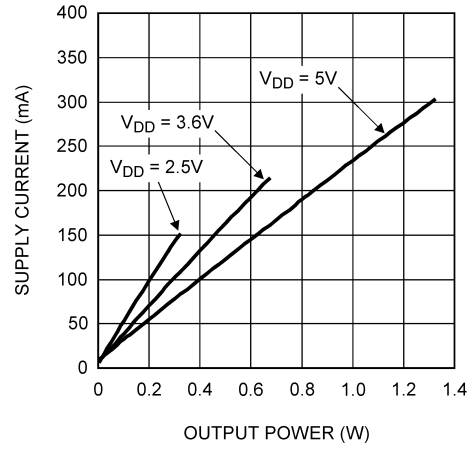

20089920

**Shutdown Threshold**  
 $R_L = 15\mu H + 8\Omega + 15\mu H$

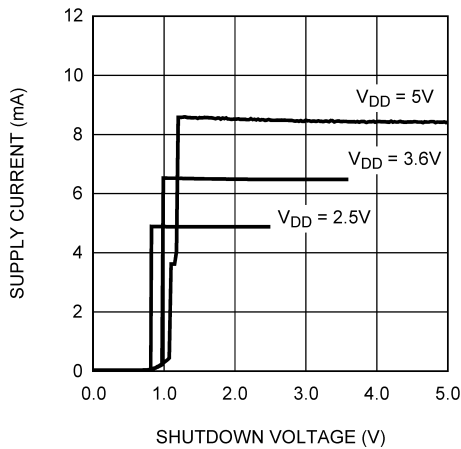

20089918

**Shutdown Threshold vs Supply Voltage**  
 $R_L = 15\mu H + 8\Omega + 15\mu H$

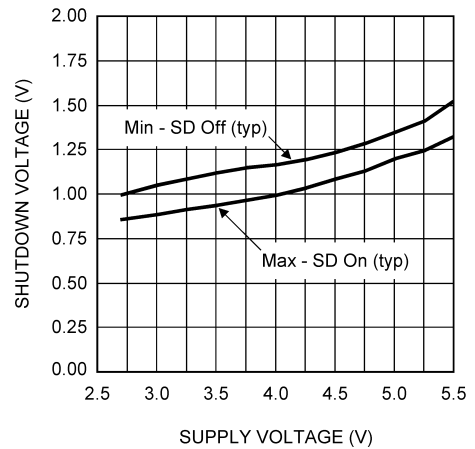

200899H5



Typical Performance Characteristics (Note 10) (Continued)

Supply Current vs Shutdown Voltage  
 $R_L = 15\mu\text{H} + 8\Omega + 15\mu\text{H}$

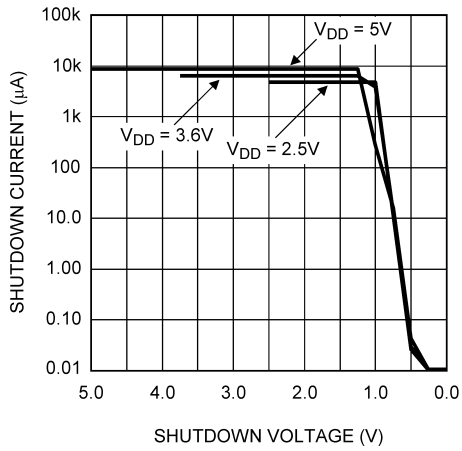

20089938

Supply Current vs Supply Voltage  
 $R_L = 15\mu\text{H} + 8\Omega + 15\mu\text{H}$

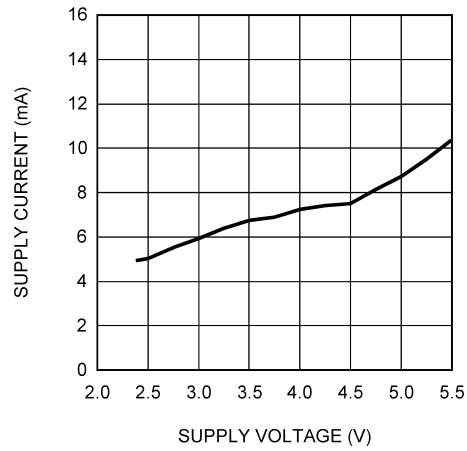

20089922

Supply Current vs Supply Voltage  
 $R_L = \text{Different } \mu\text{H loads}$

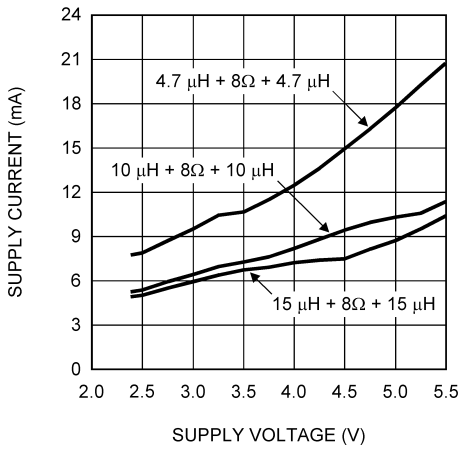

20089939

Differential Gain vs Supply Voltage  
 $R_L = 15\mu\text{H} + 8\Omega + 15\mu\text{H}, R_i = 150\text{k}\Omega, f = 1\text{kHz}$

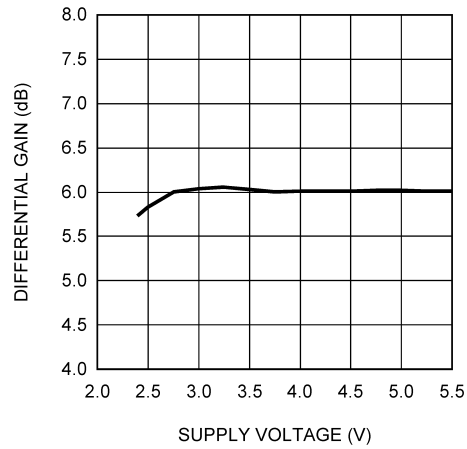

20089913

## Application Information

### GENERAL AMPLIFIER FUNCTION

The output signals generated by the LM4670 consist of two, BTL connected, output signals that pulse momentarily from near ground potential to  $V_{DD}$ . The two outputs can pulse independently with the exception that they both may never pulse simultaneously as this would result in zero volts across the BTL load. The minimum width of each pulse is approximately 350ns. However, pulses on the same output can occur sequentially, in which case they are concatenated and appear as a single wider pulse to achieve an effective 100% duty cycle. This results in maximum audio output power for a given supply voltage and load impedance. The LM4670 can achieve much higher efficiencies than class AB amplifiers while maintaining acceptable THD performance.

The short (350ns) drive pulses emitted at the LM4670 outputs means that good efficiency can be obtained with minimal load inductance. The typical transducer load on an audio amplifier is quite reactive (inductive). For this reason, the load can act as it's own filter, so to speak. This "filter-less" switching amplifier/transducer load combination is much more attractive economically due to savings in board space and external component cost by eliminating the need for a filter.

### POWER DISSIPATION AND EFFICIENCY

In general terms, efficiency is considered to be the ratio of useful work output divided by the total energy required to produce it with the difference being the power dissipated, typically, in the IC. The key here is "useful" work. For audio systems, the energy delivered in the audible bands is considered useful including the distortion products of the input signal. Sub-sonic (DC) and super-sonic components (>22kHz) are not useful. The difference between the power flowing from the power supply and the audio band power being transduced is dissipated in the LM4670 and in the transducer load. The amount of power dissipation in the LM4670 is very low. This is because the ON resistance of the switches used to form the output waveforms is typically less than  $0.25\Omega$ . This leaves only the transducer load as a potential "sink" for the small excess of input power over audio band output power. The LM4670 dissipates only a fraction of the excess power requiring no additional PCB area or cop-plane to act as a heat sink.

### DIFFERENTIAL AMPLIFIER EXPLANATION

As logic supply voltages continue to shrink, designers are increasingly turning to differential analog signal handling to preserve signal to noise ratios with restricted voltage swing. The LM4670 is a fully differential amplifier that features differential input and output stages. A differential amplifier amplifies the difference between the two input signals. Traditional audio power amplifiers have typically offered only single-ended inputs resulting in a 6dB reduction in signal to noise ratio relative to differential inputs. The LM4670 also offers the possibility of DC input coupling which eliminates the two external AC coupling, DC blocking capacitors. The LM4670 can be used, however, as a single ended input amplifier while still retaining it's fully differential benefits. In fact, completely unrelated signals may be placed on the input pins. The LM4670 simply amplifies the difference between the signals. A major benefit of a differential amplifier is the improved common mode rejection ratio (CMRR) over

single input amplifiers. The common-mode rejection characteristic of the differential amplifier reduces sensitivity to ground offset related noise injection, especially important in high noise applications.

### PCB LAYOUT CONSIDERATIONS

As output power increases, interconnect resistance (PCB traces and wires) between the amplifier, load and power supply create a voltage drop. The voltage loss on the traces between the LM4670 and the load results in lower output power and decreased efficiency. Higher trace resistance between the supply and the LM4670 has the same effect as a poorly regulated supply, increase ripple on the supply line also reducing the peak output power. The effects of residual trace resistance increases as output current increases due to higher output power, decreased load impedance or both. To maintain the highest output voltage swing and corresponding peak output power, the PCB traces that connect the output pins to the load and the supply pins to the power supply should be as wide as possible to minimize trace resistance.

The use of power and ground planes will give the best THD+N performance. While reducing trace resistance, the use of power planes also creates parasite capacitors that help to filter the power supply line.

The rising and falling edges are necessarily short in relation to the minimum pulse width (350ns), having approximately 16ns rise and fall times, typical, depending on parasitic output capacitance. The inductive nature of the transducer load can also result in overshoot on one or both edges, clamped by the parasitic diodes to GND and  $V_{DD}$  in each case. From an EMI standpoint, this is an aggressive waveform that can radiate or conduct to other components in the system and cause interference. It is essential to keep the power and output traces short and well shielded if possible. Use of ground planes, beads, and micro-strip layout techniques are all useful in preventing unwanted interference.

As the distance from the LM4670 and the speaker increase, the amount of EMI radiation will increase since the output wires or traces acting as antenna become more efficient with length. What is acceptable EMI is highly application specific. Ferrite chip inductors placed close to the LM4670 may be needed to reduce EMI radiation. The value of the ferrite chip is very application specific.

### POWER SUPPLY BYPASSING

As with any power amplifier, proper supply bypassing is critical for low noise performance and high power supply rejection ratio (PSRR). The capacitor ( $C_S$ ) location should be as close as possible to the LM4670. Typical applications employ a voltage regulator with a 10 $\mu$ F and a 0.1 $\mu$ F bypass capacitors that increase supply stability. These capacitors do not eliminate the need for bypassing on the supply pin of the LM4670. A 1 $\mu$ F tantalum capacitor is recommended.

### SHUTDOWN FUNCTION

In order to reduce power consumption while not in use, the LM4670 contains shutdown circuitry that reduces current draw to less than 0.01 $\mu$ A. The trigger point for shutdown is shown as a typical value in the Electrical Characteristics Tables and in the Shutdown Hysteresis Voltage graphs found in the **Typical Performance Characteristics** section. It is best to switch between ground and supply for minimum

## Application Information (Continued)

current usage while in the shutdown state. While the LM4670 may be disabled with shutdown voltages in between ground and supply, the idle current will be greater than the typical 0.01µA value. Increased THD may also be observed with voltages less than  $V_{DD}$  on the Shutdown pin when in PLAY mode.

The LM4670 has an internal resistor connected between GND and Shutdown pins. The purpose of this resistor is to eliminate any unwanted state changes when the Shutdown pin is floating. The LM4670 will enter the shutdown state when the Shutdown pin is left floating or if not floating, when the shutdown voltage has crossed the threshold. To minimize the supply current while in the shutdown state, the Shutdown pin should be driven to GND or left floating. If the Shutdown pin is not driven to GND, the amount of additional resistor current due to the internal shutdown resistor can be found by Equation (1) below.

$$(V_{SD} - GND) / 300k\Omega \quad (1)$$

With only a 0.5V difference, an additional 1.7µA of current will be drawn while in the shutdown state.

### PROPER SELECTION OF EXTERNAL COMPONENTS

The gain of the LM4670 is set by the external resistors,  $R_i$  in Figure 1, The Gain is given by Equation (2) below. Best THD+N performance is achieved with a gain of 2V/V (6dB).

$$A_v = 2 * 150 k\Omega / R_i (V/V) \quad (2)$$

It is recommended that resistors with 1% tolerance or better be used to set the gain of the LM4670. The  $R_i$  resistors should be placed close to the input pins of the LM4670. Keeping the input traces close to each other and of the same length in a high noise environment will aid in noise rejection due to the good CMRR of the LM4670. Noise coupled onto input traces which are physically close to each other will be common mode and easily rejected by the LM4670.

Input capacitors may be needed for some applications or when the source is single-ended (see Figures 3, 5). Input capacitors are needed to block any DC voltage at the source so that the DC voltage seen between the input terminals of the LM4670 is 0V. Input capacitors create a high-pass filter with the input resistors,  $R_i$ . The -3dB point of the high-pass filter is found using Equation (3) below.

$$f_c = 1 / (2\pi R_i C_i) (Hz) \quad (3)$$

The input capacitors may also be used to remove low audio frequencies. Small speakers cannot reproduce low bass frequencies so filtering may be desired. When the LM4670 is using a single-ended source, power supply noise on the ground is seen as an input signal by the +IN input pin that is

capacitor coupled to ground (See Figures 5 – 7). Setting the high-pass filter point above the power supply noise frequencies, 217Hz in a GSM phone, for example, will filter out this noise so it is not amplified and heard on the output. Capacitors with a tolerance of 10% or better are recommended for impedance matching.

### DIFFERENTIAL CIRCUIT CONFIGURATIONS

The LM4670 can be used in many different circuit configurations. The simplest and best performing is the DC coupled, differential input configuration shown in Figure 2. Equation (2) above is used to determine the value of the  $R_i$  resistors for a desired gain.

Input capacitors can be used in a differential configuration as shown in Figure 3. Equation (3) above is used to determine the value of the  $C_i$  capacitors for a desired frequency response due to the high-pass filter created by  $C_i$  and  $R_i$ . Equation (2) above is used to determine the value of the  $R_i$  resistors for a desired gain.

The LM4670 can be used to amplify more than one audio source. Figure 4 shows a dual differential input configuration. The gain for each input can be independently set for maximum design flexibility using the  $R_i$  resistors for each input and Equation (2). Input capacitors can be used with one or more sources as well to have different frequency responses depending on the source or if a DC voltage needs to be blocked from a source.

### SINGLE-ENDED CIRCUIT CONFIGURATIONS

The LM4670 can also be used with single-ended sources but input capacitors will be needed to block any DC at the input terminals. Figure 5 shows the typical single-ended application configuration. The equations for Gain, Equation (2), and frequency response, Equation (3), hold for the single-ended configuration as shown in Figure 5.

When using more than one single-ended source as shown in Figure 6, the impedance seen from each input terminal should be equal. To find the correct values for  $C_{i3}$  and  $R_{i3}$  connected to the +IN input pin the equivalent impedance of all the single-ended sources are calculated. The single-ended sources are in parallel to each other. The equivalent capacitor and resistor,  $C_{i3}$  and  $R_{i3}$ , are found by calculating the parallel combination of all  $C_i$  values and then all  $R_i$  values. Equations (4) and (5) below are for any number of single-ended sources.

$$C_{i3} = C_{i1} + C_{i2} + C_{in} \dots (F) \quad (4)$$

$$R_{i3} = 1 / (1/R_{i1} + 1/R_{i2} + 1/R_{in} \dots) (\Omega) \quad (5)$$

The LM4670 may also use a combination of single-ended and differential sources. A typical application with one single-ended source and one differential source is shown in Figure 7. Using the principle of superposition, the external component values can be determined with the above equations corresponding to the configuration.

Application Information (Continued)

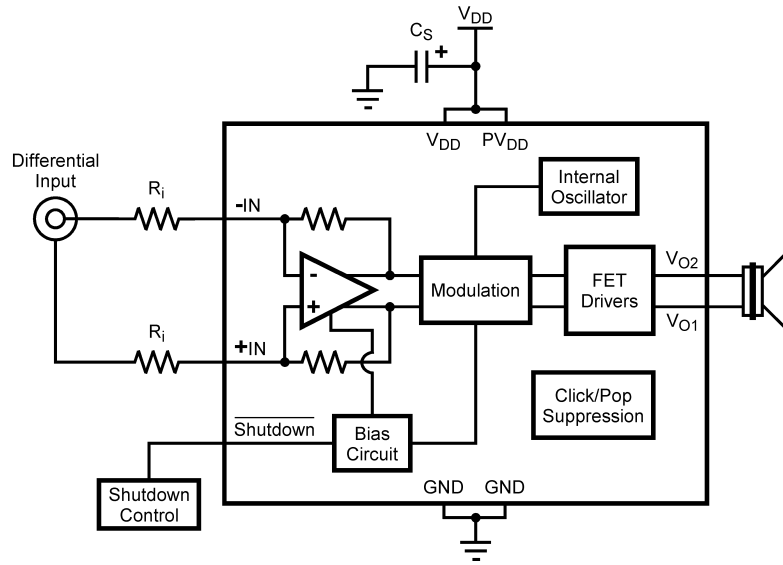

20089903

FIGURE 2. Differential input configuration

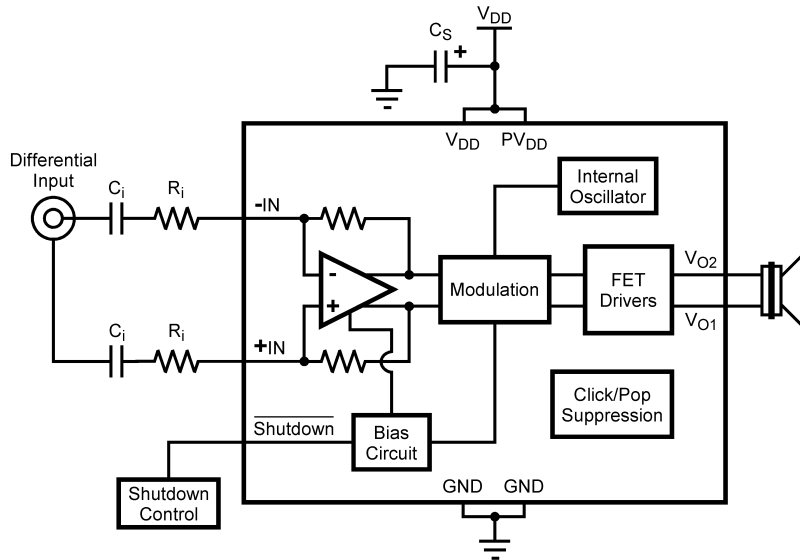

20089904

FIGURE 3. Differential input configuration with input capacitors

Application Information (Continued)

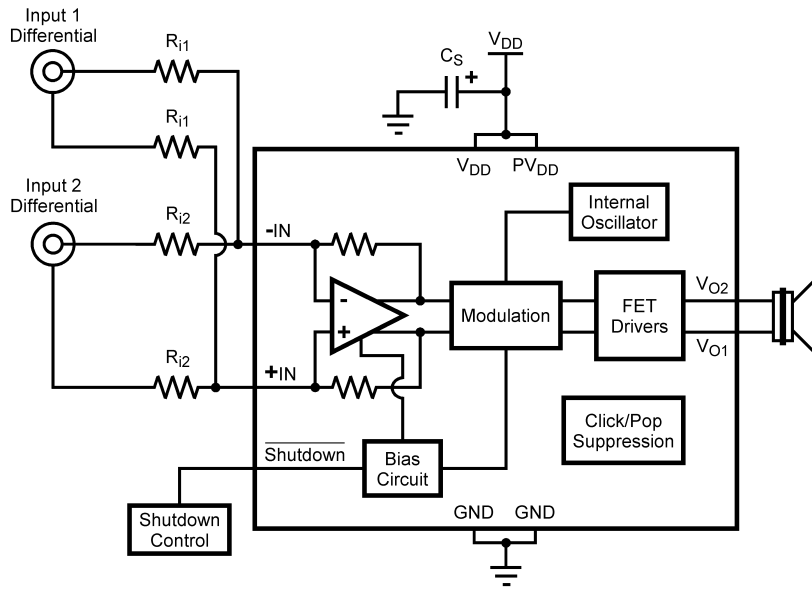

20089905

FIGURE 4. Dual differential input configuration

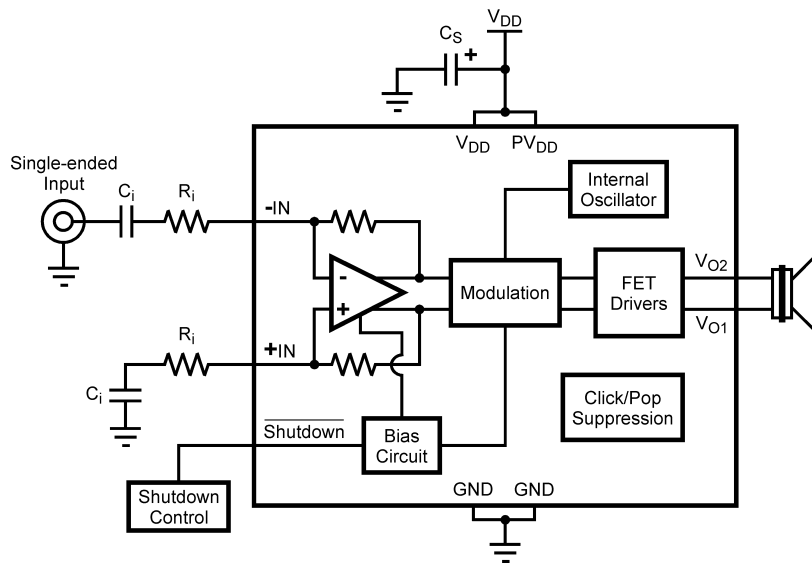

20089906

FIGURE 5. Single-ended input configuration

Application Information (Continued)

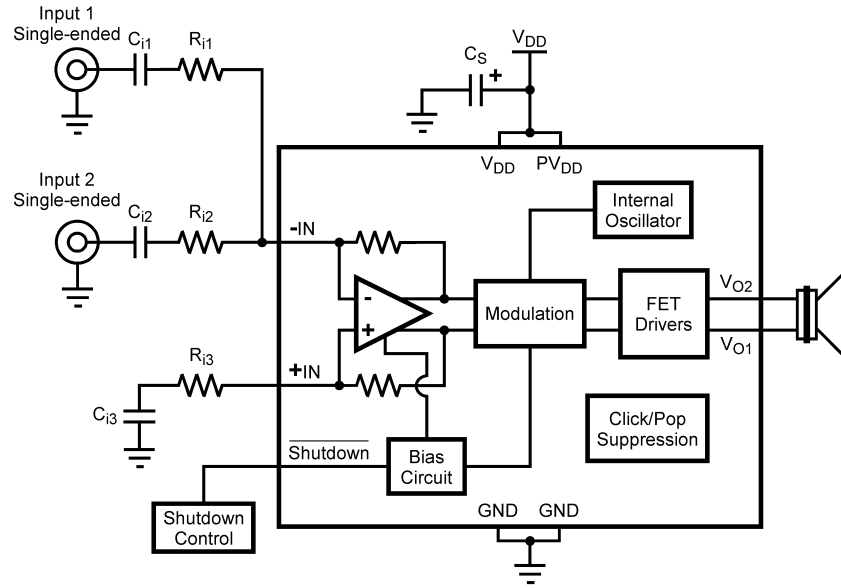

20089907

FIGURE 6. Dual single-ended input configuration

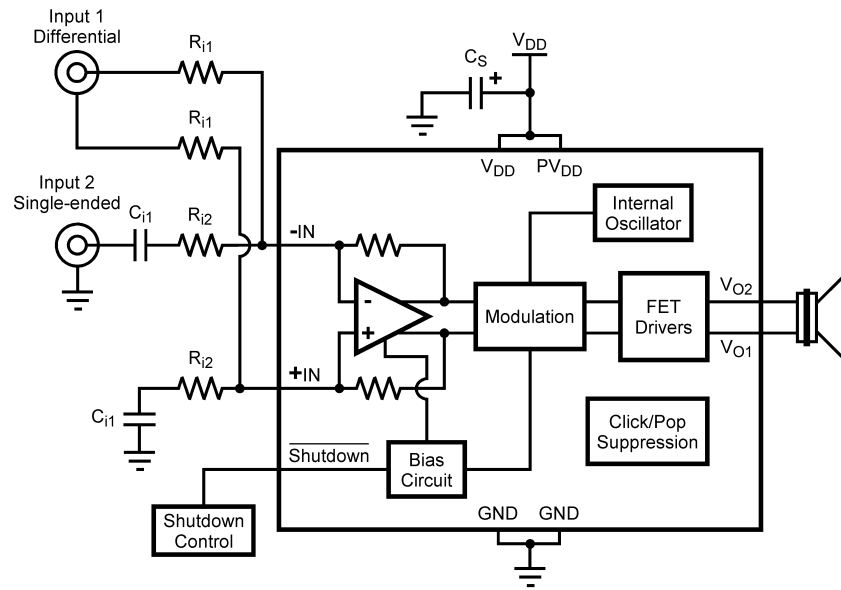

20089908

FIGURE 7. Dual input with a single-ended input and a differential input

## Application Information (Continued)

### REFERENCE DESIGN BOARD SCHEMATIC

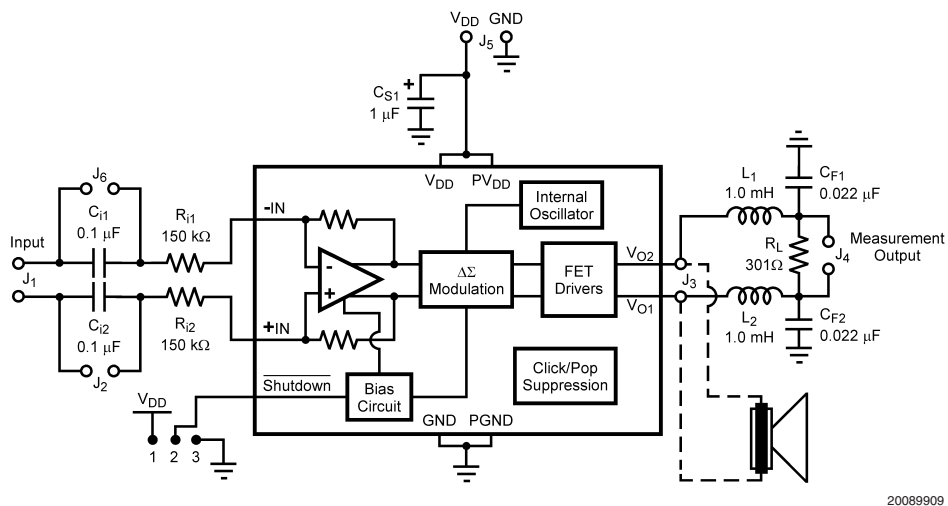

20089909

FIGURE 8.

In addition to the minimal parts required for the application circuit, a measurement filter is provided on the evaluation circuit board so that conventional audio measurements can be conveniently made without additional equipment. This is a balanced input, grounded differential output low pass filter with a 3dB frequency of approximately 35kHz and an on board termination resistor of 300Ω (see schematic). Note that the capacitive load elements are returned to ground. This is not optimal for common mode rejection purposes, but due to the independent pulse format at each output there is a significant amount of high frequency common mode component on the outputs. The grounded capacitive filter elements attenuate this component at the board to reduce the high frequency CMRR requirement placed on the analysis instruments.

Even with the grounded filter the audio signal is still differential, necessitating a differential input on any analysis instrument connected to it. Most lab instruments that feature BNC connectors on their inputs are **NOT** differential responding because the ring of the BNC is usually grounded.

The commonly used Audio Precision analyzer is differential, but its ability to accurately reject fast pulses of 350ns width is questionable necessitating the on board measurement filter. When in doubt or when the signal needs to be single-ended, use an audio signal transformer to convert the differential output to a single ended output. Depending on the audio transformer's characteristics, there may be some attenuation of the audio signal which needs to be taken into account for correct measurement of performance.

Measurements made at the output of the measurement filter suffer attenuation relative to the primary, unfiltered outputs even at audio frequencies. This is due to the resistance of the inductors interacting with the termination resistor (300Ω) and is typically about -0.25dB (3%). In other words, the voltage levels (and corresponding power levels) indicated through the measurement filter are slightly lower than those that actually occur at the load placed on the unfiltered outputs. This small loss in the filter for measurement gives a lower output power reading than what is really occurring on the unfiltered outputs and its load.

# Application Information (Continued)

## LM4670 micro SMD BOARD ARTWORK

Composite View

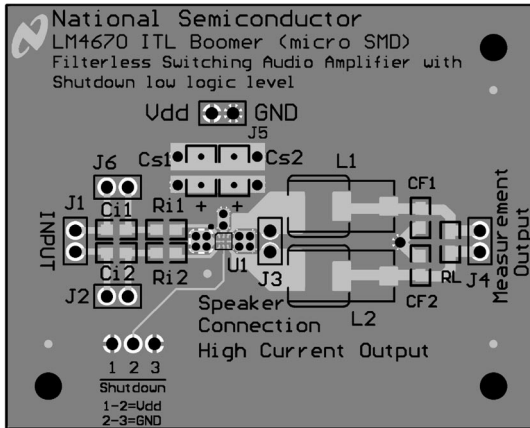

20089932

Silk Screen

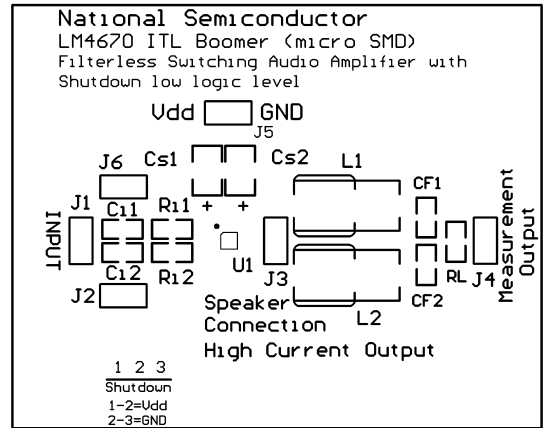

20089935

Top Layer

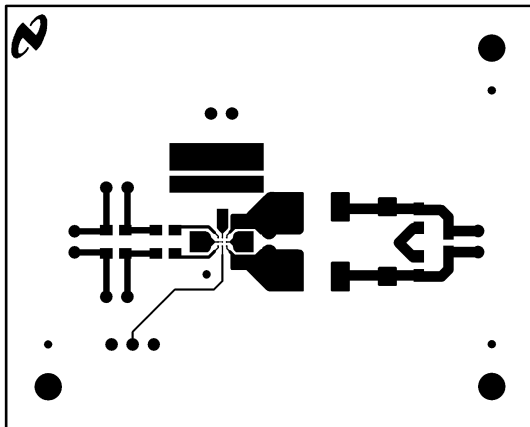

20089937

Internal Layer 1, GND

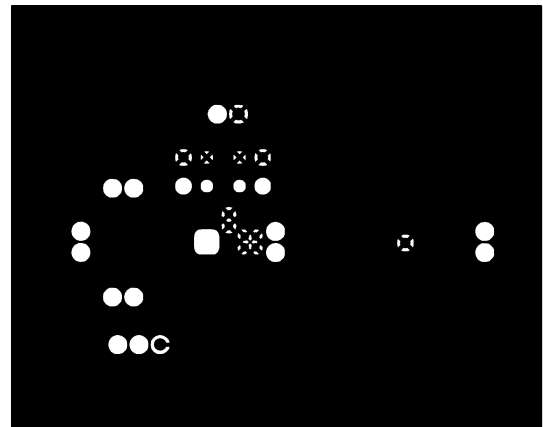

20089933

Internal Layer 2, V<sub>DD</sub>

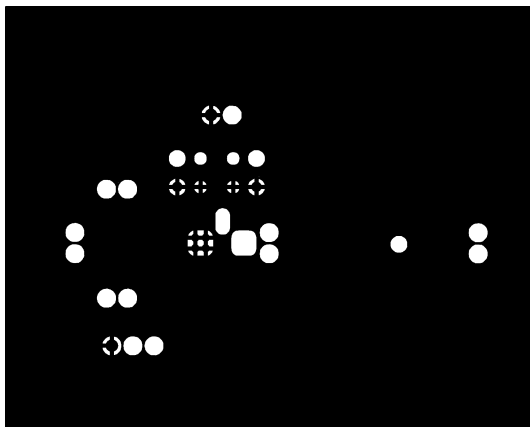

20089934

Bottom Layer

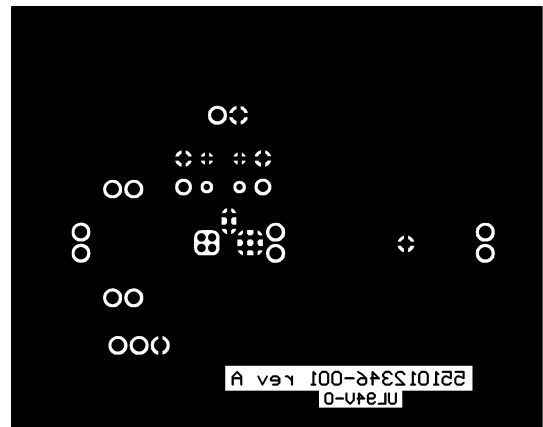

20089931



**Physical Dimensions** inches (millimeters) unless otherwise noted

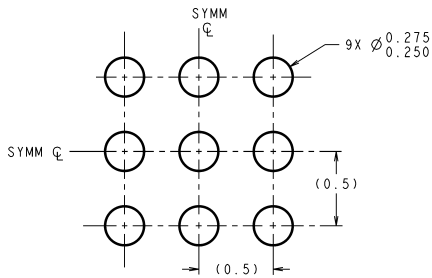

DIMENSIONS ARE IN MILLIMETERS  
DIMENSIONS IN ( ) FOR REFERENCE ONLY

**LAND PATTERN RECOMMENDATION**

TOP SIDE COATING

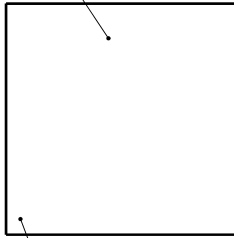

BUMP A1 CORNER

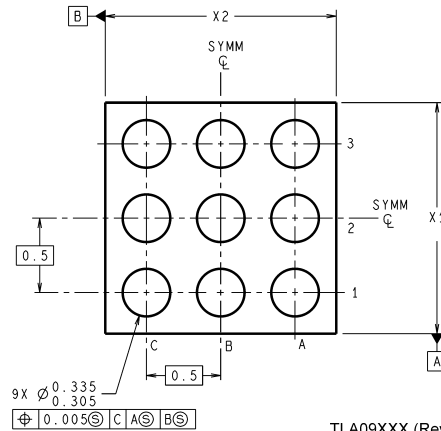
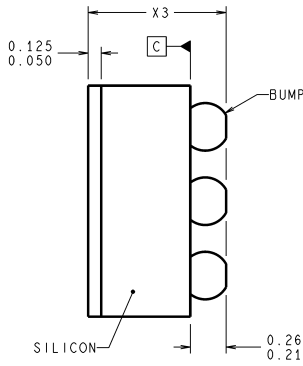

TLA09XXX (Rev C)

**9 Bump micro SMD**  
**Order Number LM4670ITL, LM4670ITLX**  
**NS Package Number TLA09ZZA**  
**X1 = 1.463 X2 = 1.463 X3 = 0.600**

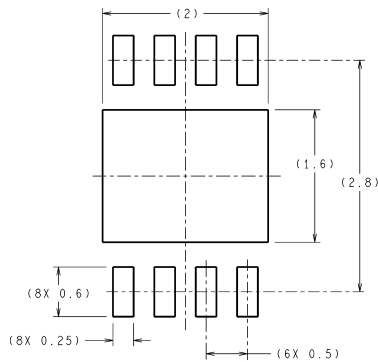

**RECOMMENDED LAND PATTERN**

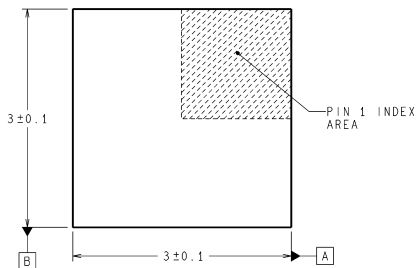

DIMENSIONS ARE IN MILLIMETERS  
DIMENSIONS IN ( ) FOR REFERENCE ONLY

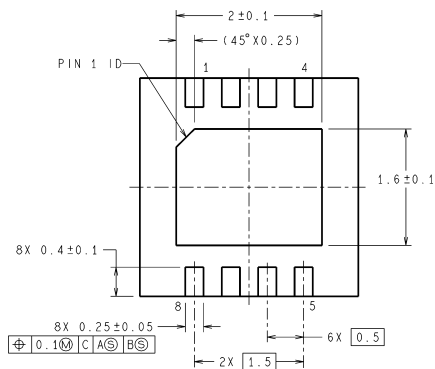
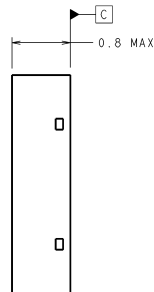

SDA08A (Rev A)

**LLP**  
**Order Number LM4670SD**  
**NS Package Number SDA08A**

## Notes

National does not assume any responsibility for use of any circuitry described, no circuit patent licenses are implied and National reserves the right at any time without notice to change said circuitry and specifications.

For the most current product information visit us at [www.national.com](http://www.national.com).

### LIFE SUPPORT POLICY

NATIONAL'S PRODUCTS ARE NOT AUTHORIZED FOR USE AS CRITICAL COMPONENTS IN LIFE SUPPORT DEVICES OR SYSTEMS WITHOUT THE EXPRESS WRITTEN APPROVAL OF THE PRESIDENT AND GENERAL COUNSEL OF NATIONAL SEMICONDUCTOR CORPORATION. As used herein:

1. Life support devices or systems are devices or systems which, (a) are intended for surgical implant into the body, or (b) support or sustain life, and whose failure to perform when properly used in accordance with instructions for use provided in the labeling, can be reasonably expected to result in a significant injury to the user.
2. A critical component is any component of a life support device or system whose failure to perform can be reasonably expected to cause the failure of the life support device or system, or to affect its safety or effectiveness.

### BANNED SUBSTANCE COMPLIANCE

National Semiconductor certifies that the products and packing materials meet the provisions of the Customer Products Stewardship Specification (CSP-9-111C2) and the Banned Substances and Materials of Interest Specification (CSP-9-111S2) and contain no "Banned Substances" as defined in CSP-9-111S2.



**National Semiconductor**  
**Americas Customer**  
**Support Center**  
Email: [new.feedback@nsc.com](mailto:new.feedback@nsc.com)  
Tel: 1-800-272-9959

[www.national.com](http://www.national.com)

**National Semiconductor**  
**Europe Customer Support Center**  
Fax: +49 (0) 180-530 85 86  
Email: [europe.support@nsc.com](mailto:europe.support@nsc.com)  
Deutsch Tel: +49 (0) 69 9508 6208  
English Tel: +44 (0) 870 24 0 2171  
Français Tel: +33 (0) 1 41 91 8790

**National Semiconductor**  
**Asia Pacific Customer**  
**Support Center**  
Email: [ap.support@nsc.com](mailto:ap.support@nsc.com)

**National Semiconductor**  
**Japan Customer Support Center**  
Fax: 81-3-5639-7507  
Email: [jpn.feedback@nsc.com](mailto:jpn.feedback@nsc.com)  
Tel: 81-3-5639-7560