

SURFACE MOUNT DISPLAY



SUN LED

XZDVG10C

Email : sales@us.sunled.com
Web Site : www.sunled.com

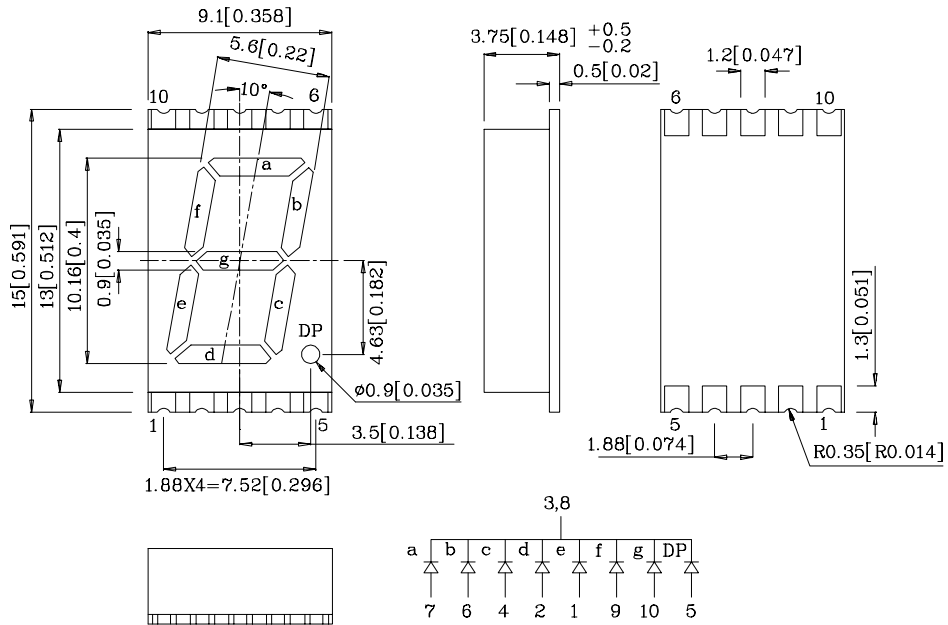

Notes:

1. All dimensions are in millimeters (inches).
2. Tolerance is ±0.25(0.01") unless otherwise noted.

Absolute maximum ratings (TA=25°C)		VG (InGaAlP)	Unit
Reverse voltage	VR	5	V
Forward current	IF	30	mA
Forward current (peak) 1/10Duty cycle 0.1ms pulse width	ifs	150	mA
Power dissipation	PT	105	mW
Operating temperature	TA	-40 ~ +85	°C
Storage temperature	Tstg		

Operating Characteristics (TA=25°C)		VG (InGaAlP)	Unit
Forward voltage (typ.) (IF=10mA)	VF	2.0	V
Forward voltage (max.) (IF=10mA)	VF	2.5	V
Reverse current (VR=5V)	IR	10	uA
Wavelength at peak emission (IF=10mA)	λpeak	574	nm
Wavelength at Dominate emission (IF=10mA)	λD	570	nm
Spectral Line half-width (IF=10mA)	Δλ	20	nm
Capacitance (VF=0V, f=1MHz)	C	15	pF

Part Number	Emitting Color	Emitting Material	Luminous Intensity (IF=10mA) ucd		Wavelength nm λP	Description
			min.	typ.		
XZDVG10C	Green	InGaAlP	8000	16400	574	Common Cathode, Rt.Hand Decimal

XZDVG10C

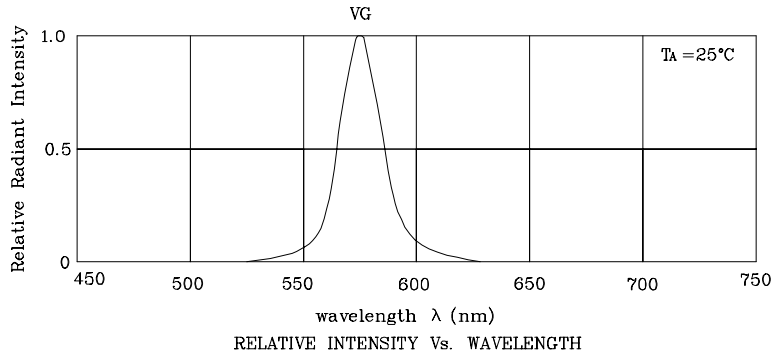

❖VG

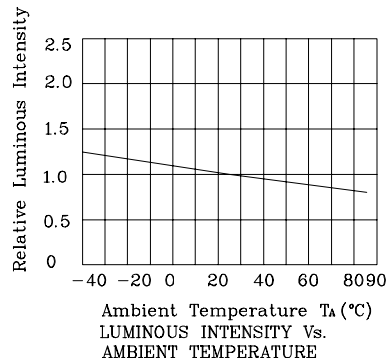
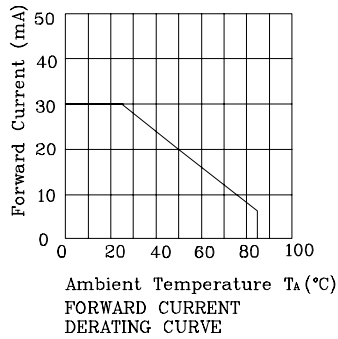
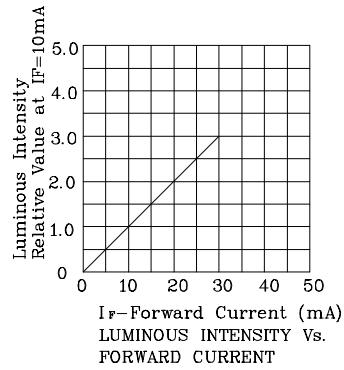
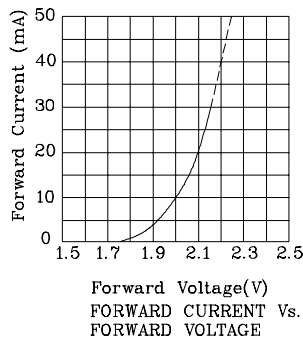

XZDVG10C

❖SMT Reflow Soldering Instructions

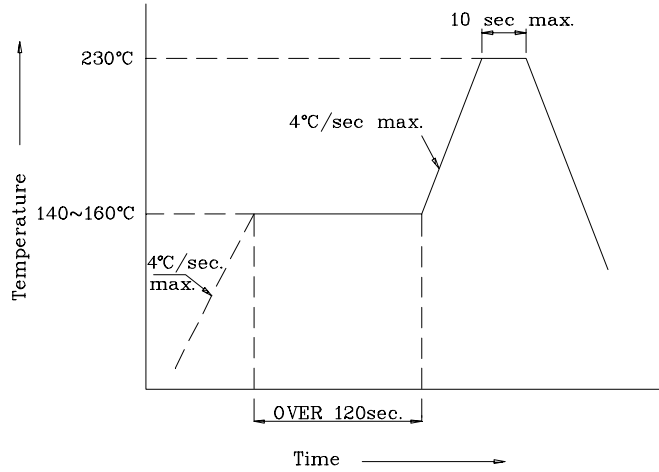

❖Recommended Soldering Pattern (Units : mm, Tolerance : ±0.15)

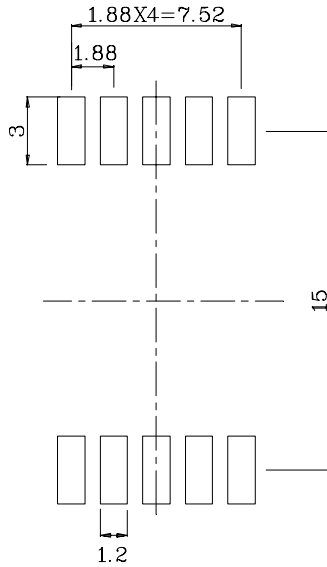

❖Tape Specification (Units : mm)

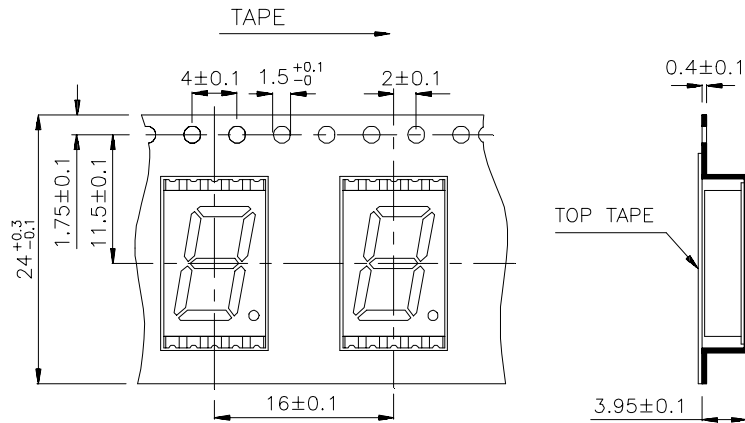

PACKAGE : 800PCS / REEL.