

# 0.5 Amp Output Current IGBT Gate Drive Optocoupler

## Technical Data

### HCPL-3150

#### Features

- **0.5 A Minimum Peak Output Current**
- **15 kV/ $\mu$ s Minimum Common Mode Rejection (CMR) at  $V_{CM} = 1500$  V**
- **1.0 V Maximum Low Level Output Voltage ( $V_{OL}$ ) Eliminates Need for Negative Gate Drive**
- **$I_{CC} = 5$  mA Maximum Supply Current**
- **Under Voltage Lock-Out Protection (UVLO) with Hysteresis**
- **Wide Operating  $V_{CC}$  Range: 15 to 30 Volts**
- **500 ns Maximum Switching Speeds**
- **Industrial Temperature Range: -40°C to 100°C**
- **Safety and Regulatory Approval:**  
UL Recognized  
2500 Vrms for 1 min. per UL1577  
VDE 0884 Approved with  $V_{IORM} = 630$  Vpeak (Option 060 only)  
CSA Approved

#### Applications

- **Isolated IGBT/MOSFET Gate Drive**
- **AC and Brushless DC Motor Drives**
- **Industrial Inverters**
- **Switch Mode Power Supplies (SMPS)**

#### Description

The HCPL-3150 consists of a GaAsP LED optically coupled to an integrated circuit with a power output stage. This optocoupler is

ideally suited for driving power IGBTs and MOSFETs used in motor control inverter applications. The high operating voltage range of the output stage provides the drive voltages required by gate controlled devices. The voltage and current supplied by this optocoupler makes it ideally suited for directly driving IGBTs with ratings up to 1200 V/50 A. For IGBTs with higher ratings, the HCPL-3120 can be used to drive a discrete power stage which drives the IGBT gate.

#### Functional Diagram

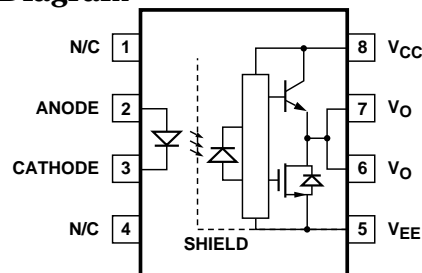

#### Truth Table

LED	$V_{CC} - V_{EE}$ "Positive Going" (i.e., Turn-On)	$V_{CC} - V_{EE}$ "Negative-Going" (i.e., Turn-Off)	$V_O$
OFF	0 - 30 V	0 - 30 V	LOW
ON	0 - 11 V	0 - 9.5 V	LOW
ON	11 - 13.5 V	9.5 - 12 V	TRANSITION
ON	13.5 - 30 V	12 - 30 V	HIGH

A 0.1  $\mu$ F bypass capacitor must be connected between pins 5 and 8.

**CAUTION:** It is advised that normal static precautions be taken in handling and assembly of this component to prevent damage and/or degradation which may be induced by ESD.

## Ordering Information

Specify Part Number followed by Option Number (if desired)

Example

HCPL-3150#XXX

- No Option = Standard DIP package, 50 per tube.
- 060 = VDE 0884  $V_{IORM} = 630$  Vpeak Option, 50 per tube.
- 300 = Gull Wing Surface Mount Option, 50 per tube.
- 500 = Tape and Reel Packaging Option, 1000 per reel.

Option data sheets available. Contact Hewlett-Packard sales representative or authorized distributor.

## Package Outline Drawings

### Standard DIP Package

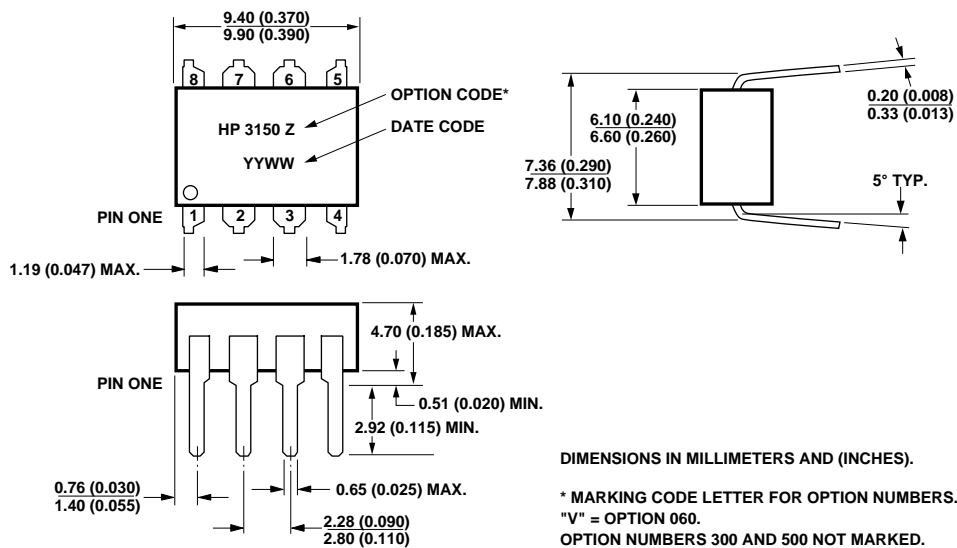

### Gull-Wing Surface-Mount Option 300

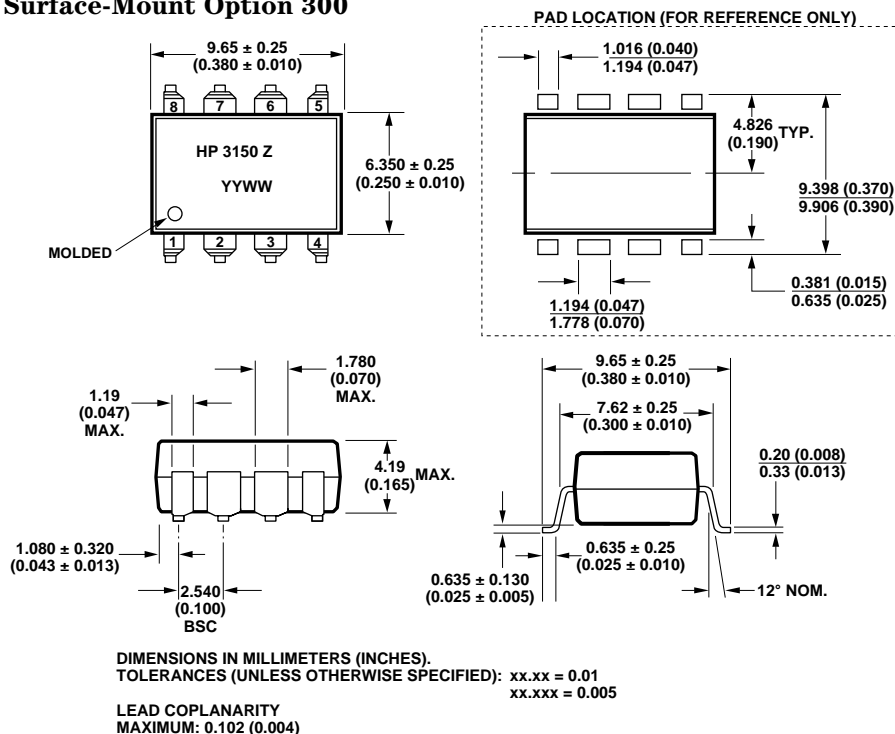

## Reflow Temperature Profile

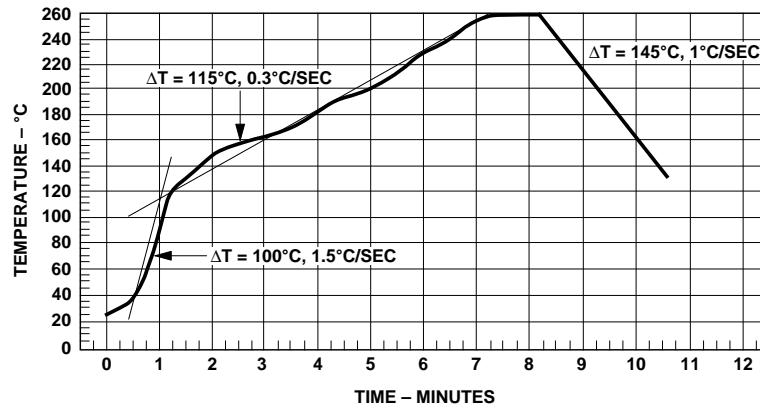

MAXIMUM SOLDER REFLOW THERMAL PROFILE  
(NOTE: USE OF NON-CHLORINE ACTIVATED FLUXES IS RECOMMENDED.)

## Regulatory Information

The HCPL-3150 has been approved by the following organizations:

### UL

Recognized under UL 1577, Component Recognition Program, File E55361.

### CSA

Approved under CSA Component Acceptance Notice #5, File CA 88324.

### VDE (Option 060 only)

Approved under VDE 0884/06.92 with  $V_{IORM} = 630 V_{peak}$ .

## VDE 0884 Insulation Characteristics (Option 060 Only)

Description	Symbol	Characteristic	Unit
Installation classification per DIN VDE 0110/1.89, Table 1 for rated mains voltage $\leq 300$ Vrms for rated mains voltage $\leq 600$ Vrms		I-IV I-III	
Climatic Classification		55/100/21	
Pollution Degree (DIN VDE 0110/1.89)		2	
Maximum Working Insulation Voltage	$V_{IORM}$	630	$V_{peak}$
Input to Output Test Voltage, Method b* $V_{IORM} \times 1.875 = V_{PR}$ , 100% Production Test with $t_m = 1$ sec, Partial discharge $< 5$ pC	$V_{PR}$	1181	$V_{peak}$
Input to Output Test Voltage, Method a* $V_{IORM} \times 1.5 = V_{PR}$ , Type and Sample Test, $t_m = 60$ sec, Partial discharge $< 5$ pC	$V_{PR}$	945	$V_{peak}$
Highest Allowable Overvoltage* (Transient Overvoltage $t_{ini} = 10$ sec)	$V_{IOTM}$	6000	$V_{peak}$
Safety-Limiting Values – Maximum Values Allowed in the Event of a Failure, Also See Figure 37, Thermal Derating Curve.			
Case Temperature	$T_S$	175	$^{\circ}C$
Input Current	$I_S, INPUT$	230	mA
Output Power	$P_S, OUTPUT$	600	mW
Insulation Resistance at $T_S, V_{IO} = 500$ V	$R_S$	$\geq 10^9$	$\Omega$

\*Refer to the front of the optocoupler section of the current Catalog, under Product Safety Regulations section, (VDE 0884) for a detailed description of Method a and Method b partial discharge test profiles.

**Note:** Isolation characteristics are guaranteed only within the safety maximum ratings which must be ensured by protective circuits in application.

## Insulation and Safety Related Specifications

Parameter	Symbol	Value	Units	Conditions
Minimum External Air Gap (External Clearance)	L(101)	7.1	mm	Measured from input terminals to output terminals, shortest distance through air.
Minimum External Tracking (External Creepage)	L(102)	7.4	mm	Measured from input terminals to output terminals, shortest distance path along body.
Minimum Internal Plastic Gap (Internal Clearance)		0.08	mm	Through insulation distance conductor to conductor.
Tracking Resistance (Comparative Tracking Index)	CTI	200	Volts	DIN IEC 112/VDE 0303 Part 1
Isolation Group		IIIa		Material Group (DIN VDE 0110, 1/89, Table 1)

Option 300 - surface mount classification is Class A in accordance with CECC 00802.

## Absolute Maximum Ratings

Parameter	Symbol	Min.	Max.	Units	Note
Storage Temperature	$T_S$	-55	125	°C	
Operating Temperature	$T_A$	-40	100	°C	
Average Input Current	$I_{F(AVG)}$		25	mA	1
Peak Transient Input Current ( $<1 \mu s$ pulse width, 300 pps)	$I_{F(TRAN)}$		1.0	A	
Reverse Input Voltage	$V_R$		5	Volts	
“High” Peak Output Current	$I_{OH(PEAK)}$		0.6	A	2
“Low” Peak Output Current	$I_{OL(PEAK)}$		0.6	A	2
Supply Voltage	$(V_{CC} - V_{EE})$	0	35	Volts	
Output Voltage	$V_{O(PEAK)}$	0	$V_{CC}$	Volts	
Output Power Dissipation	$P_O$		250	mW	3
Total Power Dissipation	$P_T$		295	mW	4
Lead Solder Temperature	260°C for 10 sec., 1.6 mm below seating plane				
Solder Reflow Temperature Profile	See Package Outline Drawings Section				

## Recommended Operating Conditions

Parameter	Symbol	Min.	Max.	Units
Power Supply Voltage	$(V_{CC} - V_{EE})$	15	30	Volts
Input Current (ON)	$I_{F(ON)}$	7	16	mA
Input Voltage (OFF)	$V_{F(OFF)}$	-3.0	0.8	V
Operating Temperature	$T_A$	-40	100	°C

## Electrical Specifications (DC)

Over recommended operating conditions ( $T_A = -40$  to  $100^\circ\text{C}$ ,  $I_{F(\text{ON})} = 7$  to  $16$  mA,  $V_{F(\text{OFF})} = -3.0$  to  $0.8$  V,  $V_{CC} = 15$  to  $30$  V,  $V_{EE} = \text{Ground}$ ) unless otherwise specified.

Parameter	Symbol	Min.	Typ.*	Max.	Units	Test Conditions	Fig.	Note
High Level Output Current	$I_{OH}$	0.1	0.4		A	$V_O = (V_{CC} - 4 \text{ V})$	2, 3,	5
		0.5				$V_O = (V_{CC} - 15 \text{ V})$	17	2
Low Level Output Current	$I_{OL}$	0.1	0.6		A	$V_O = (V_{EE} + 2.5 \text{ V})$	5, 6	5
		0.5				$V_O = (V_{EE} + 15 \text{ V})$	18	2
High Level Output Voltage	$V_{OH}$	$(V_{CC} - 4)$	$(V_{CC} - 3)$		V	$I_O = -100 \text{ mA}$	1, 3 19	6, 7
Low Level Output Voltage	$V_{OL}$		0.4	1.0	V	$I_O = 100 \text{ mA}$	4, 6 20	
High Level Supply Current	$I_{CCH}$		2.5	5.0	mA	Output Open, $I_F = 7$ to $16 \text{ mA}$	7, 8	
Low Level Supply Current	$I_{CCL}$		2.7	5.0	mA	Output Open, $V_F = -3.0$ to $+0.8 \text{ V}$		
Threshold Input Current Low to High	$I_{FLH}$		2.2	5.0	mA	$I_O = 0 \text{ mA}$ , $V_O > 5 \text{ V}$	9, 15, 21	
Threshold Input Voltage High to Low	$V_{FHL}$	0.8			V			
Input Forward Voltage	$V_F$	1.2	1.5	1.8	V	$I_F = 10 \text{ mA}$	16	
Temperature Coefficient of Forward Voltage	$\Delta V_F / \Delta T_A$		-1.6		mV/ $^\circ\text{C}$	$I_F = 10 \text{ mA}$		
Input Reverse Breakdown Voltage	$BV_R$	5			V	$I_R = 10 \mu\text{A}$		
Input Capacitance	$C_{IN}$		60		pF	$f = 1 \text{ MHz}$ , $V_F = 0 \text{ V}$		
UVLO Threshold	$V_{UVLO+}$	11.0	12.3	13.5	V	$V_O > 5 \text{ V}$ , $I_F = 10 \text{ mA}$	22, 36	
	$V_{UVLO-}$	9.5	10.7	12.0				
UVLO Hysteresis	$UVLO_{HYS}$		1.6		V			

\*All typical values at  $T_A = 25^\circ\text{C}$  and  $V_{CC} - V_{EE} = 30 \text{ V}$ , unless otherwise noted.

## Switching Specifications (AC)

Over recommended operating conditions ( $T_A = -40$  to  $100^\circ\text{C}$ ,  $I_{F(\text{ON})} = 7$  to  $16$  mA,  $V_{F(\text{OFF})} = -3.0$  to  $0.8$  V,  $V_{CC} = 15$  to  $30$  V,  $V_{EE} = \text{Ground}$ ) unless otherwise specified.

Parameter	Symbol	Min.	Typ.*	Max.	Units	Test Conditions	Fig.	Note	
Propagation Delay Time to High Output Level	$t_{\text{PLH}}$	0.10	0.30	0.50	$\mu\text{s}$	$R_g = 47 \Omega$ , $C_g = 3 \text{ nF}$ , $f = 10 \text{ kHz}$ , Duty Cycle = 50%	10, 11, 12, 13 14, 23	14	
Propagation Delay Time to Low Output Level	$t_{\text{PHL}}$	0.10	0.27	0.50	$\mu\text{s}$				
Pulse Width Distortion	PWD			0.3	$\mu\text{s}$				
Propagation Delay Difference Between Any Two Parts	PDD ( $t_{\text{PHL}} - t_{\text{PLH}}$ )	-0.35		0.35	$\mu\text{s}$			34,35	10
Rise Time	$t_r$		0.1		$\mu\text{s}$			23	
Fall Time	$t_f$		0.1		$\mu\text{s}$				
UVLO Turn On Delay	$t_{\text{UVLO ON}}$		0.8		$\mu\text{s}$	$V_O > 5 \text{ V}$ , $I_F = 10 \text{ mA}$	22		
UVLO Turn Off Delay	$t_{\text{UVLO OFF}}$		0.6		$\mu\text{s}$	$V_O < 5 \text{ V}$ , $I_F = 10 \text{ mA}$			
Output High Level Common Mode Transient Immunity	$ CM_H $	15	30		kV/ $\mu\text{s}$	$T_A = 25^\circ\text{C}$ , $I_F = 10$ to $16 \text{ mA}$ , $V_{CM} = 1500 \text{ V}$ , $V_{CC} = 30 \text{ V}$	24	11, 12	
Output Low Level Common Mode Transient Immunity	$ CM_L $	15	30		kV/ $\mu\text{s}$			$T_A = 25^\circ\text{C}$ , $V_{CM} = 1500 \text{ V}$ , $V_F = 0 \text{ V}$ , $V_{CC} = 30 \text{ V}$	11, 13

## Package Characteristics

Parameter	Symbol	Min.	Typ.*	Max.	Units	Test Conditions	Fig.	Note
Input-Output Momentary Withstand Voltage**	$V_{\text{ISO}}$	2500			Vrms	$RH < 50\%$ , $t = 1 \text{ min.}$ , $T_A = 25^\circ\text{C}$		8, 9
Resistance (Input - Output)	$R_{\text{I-O}}$		$10^{12}$		$\Omega$	$V_{\text{I-O}} = 500 \text{ V}_{\text{DC}}$		9
Capacitance (Input - Output)	$C_{\text{I-O}}$		0.6		pF	$f = 1 \text{ MHz}$		
LED-to-Case Thermal Resistance	$\theta_{\text{LC}}$		391		$^\circ\text{C/W}$	Thermocouple located at center underside of package	28	
LED-to-Detector Thermal Resistance	$\theta_{\text{LD}}$		439		$^\circ\text{C/W}$			
Detector-to-Case Thermal Resistance	$\theta_{\text{DC}}$		119		$^\circ\text{C/W}$			

\*All typical values at  $T_A = 25^\circ\text{C}$  and  $V_{CC} - V_{EE} = 30 \text{ V}$ , unless otherwise noted.

\*\*The Input-Output Momentary Withstand Voltage is a dielectric voltage rating that should not be interpreted as an input-output continuous voltage rating. For the continuous voltage rating refer to your equipment level safety specification or HP Application Note 1074 entitled "Optocoupler Input-Output Endurance Voltage."

**Notes:**

1. Derate linearly above 70°C free-air temperature at a rate of 0.3 mA/°C.
2. Maximum pulse width = 10 μs, maximum duty cycle = 0.2%. This value is intended to allow for component tolerances for designs with I<sub>O</sub> peak minimum = 0.5 A. See Applications section for additional details on limiting I<sub>OH</sub> peak.
3. Derate linearly above 70°C free-air temperature at a rate of 4.8 mW/°C.
4. Derate linearly above 70°C free-air temperature at a rate of 5.4 mW/°C. The maximum LED junction temperature should not exceed 125°C.
5. Maximum pulse width = 50 μs, maximum duty cycle = 0.5%.
6. In this test V<sub>OH</sub> is measured with a dc load current. When driving capacitive

- loads V<sub>OH</sub> will approach V<sub>CC</sub> as I<sub>OH</sub> approaches zero amps.
7. Maximum pulse width = 1 ms, maximum duty cycle = 20%.
8. In accordance with UL1577, each optocoupler is proof tested by applying an insulation test voltage ≥ 3000 Vrms for 1 second (leakage detection current limit, I<sub>L0</sub> ≤ 5 μA). This test is performed before the 100% production test for partial discharge (method b) shown in the VDE 0884 Insulation Characteristics Table, if applicable.
9. Device considered a two-terminal device: pins 1, 2, 3, and 4 shorted together and pins 5, 6, 7, and 8 shorted together.
10. The difference between t<sub>PHL</sub> and t<sub>PLH</sub> between any two HCPL-3150 parts

- under the same test condition.
11. Pins 1 and 4 need to be connected to LED common.
12. Common mode transient immunity in the high state is the maximum tolerable |dV<sub>CM</sub>/dt| of the common mode pulse, V<sub>CM</sub>, to assure that the output will remain in the high state (i.e., V<sub>O</sub> > 15.0 V).
13. Common mode transient immunity in a low state is the maximum tolerable |dV<sub>CM</sub>/dt| of the common mode pulse, V<sub>CM</sub>, to assure that the output will remain in a low state (i.e., V<sub>O</sub> < 1.0 V).
14. This load condition approximates the gate load of a 1200 V/25 A IGBT.
15. Pulse Width Distortion (PWD) is defined as |t<sub>PHL</sub> - t<sub>PLH</sub>| for any given device.

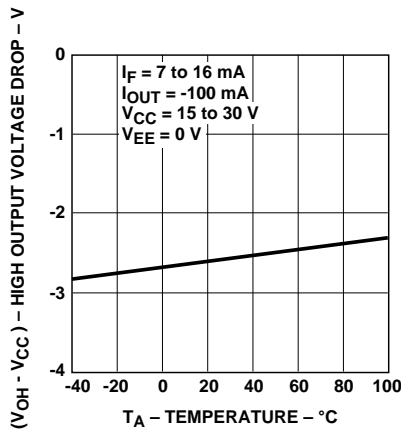

Figure 1. V<sub>OH</sub> vs. Temperature.

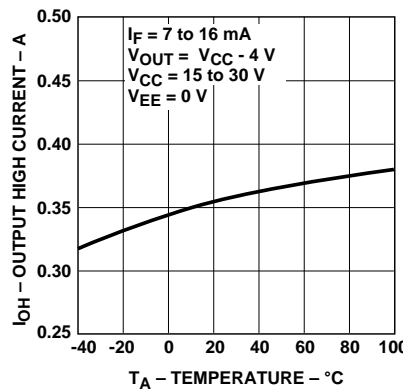

Figure 2. I<sub>OH</sub> vs. Temperature.

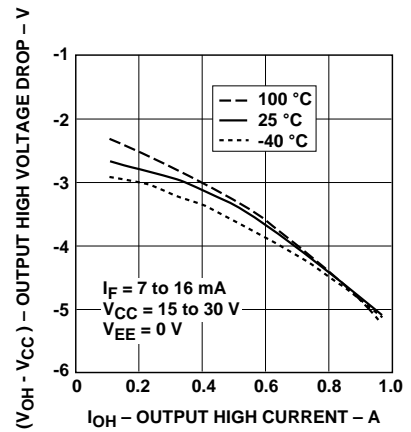

Figure 3. V<sub>OH</sub> vs. I<sub>OH</sub>.

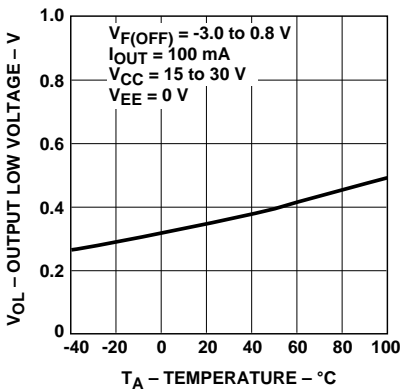

Figure 4. V<sub>OL</sub> vs. Temperature.

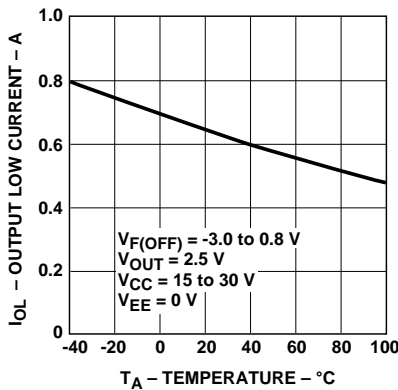

Figure 5. I<sub>OL</sub> vs. Temperature.

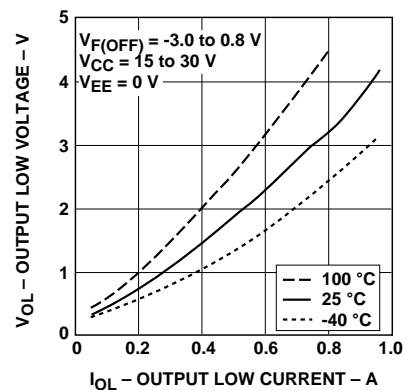

Figure 6. V<sub>OL</sub> vs. I<sub>OL</sub>.

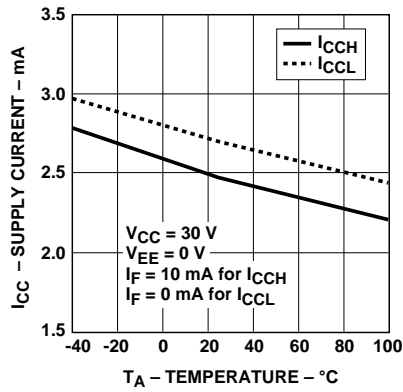

Figure 7.  $I_{CC}$  vs. Temperature.

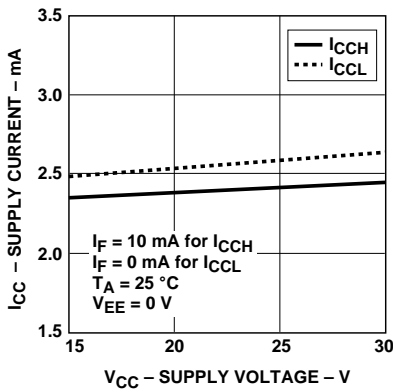

Figure 8.  $I_{CC}$  vs.  $V_{CC}$ .

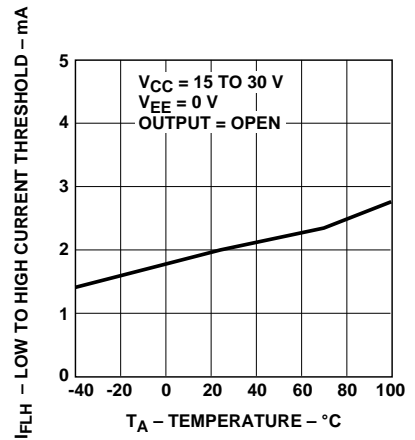

Figure 9.  $I_{FLH}$  vs. Temperature.

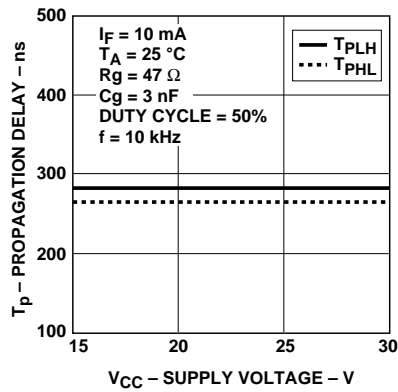

Figure 10. Propagation Delay vs.  $V_{CC}$ .

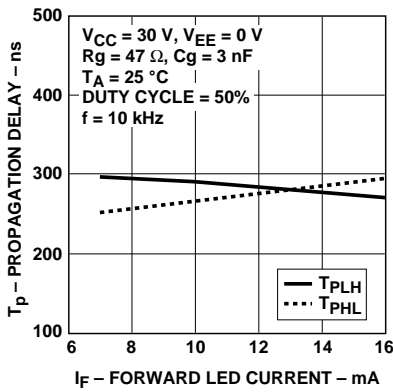

Figure 11. Propagation Delay vs.  $I_F$ .

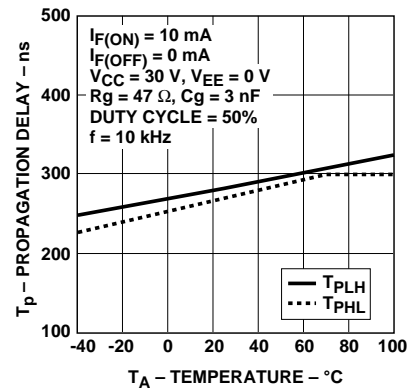

Figure 12. Propagation Delay vs. Temperature.

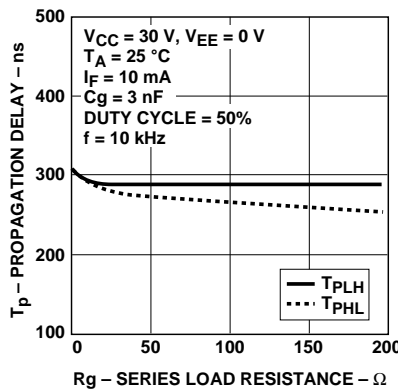

Figure 13. Propagation Delay vs.  $R_g$ .

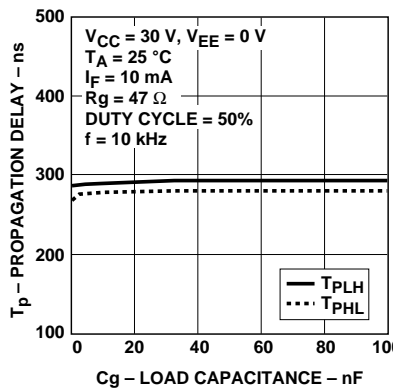

Figure 14. Propagation Delay vs.  $C_g$ .

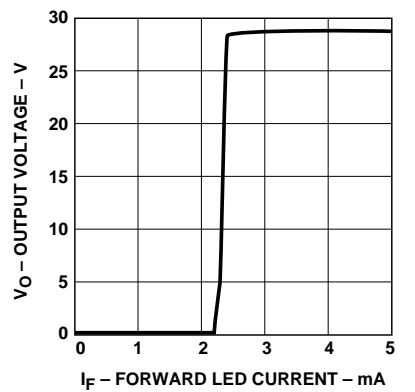

Figure 15. Transfer Characteristics.



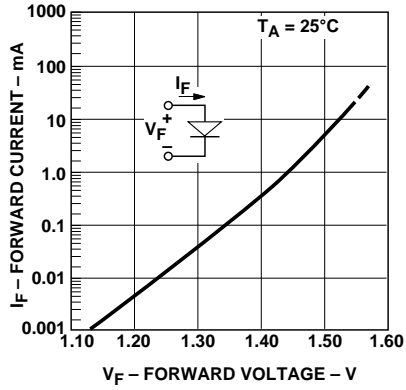

Figure 16. Input Current vs. Forward Voltage.

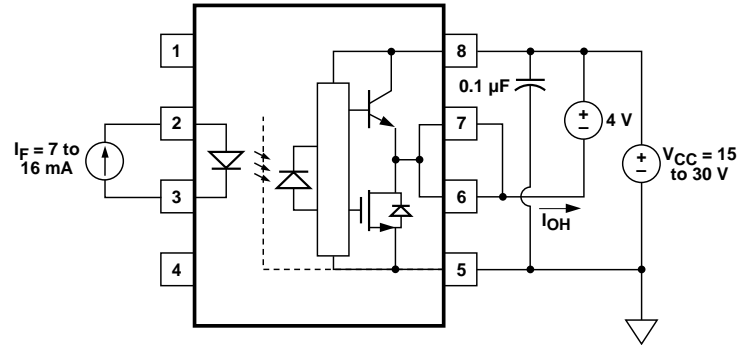

Figure 17.  $I_{OH}$  Test Circuit.

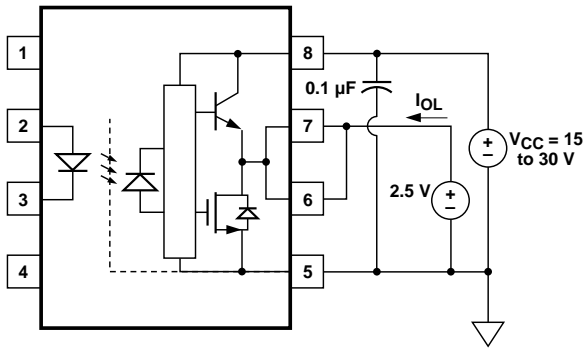

Figure 18.  $I_{OL}$  Test Circuit.

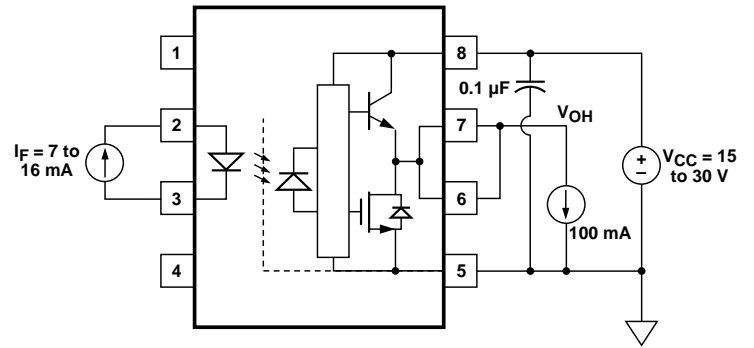

Figure 19.  $V_{OH}$  Test Circuit.

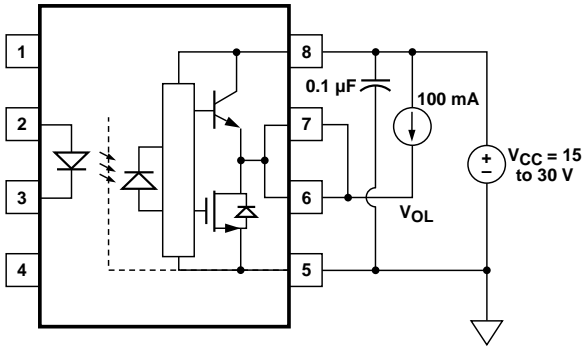

Figure 20.  $V_{OL}$  Test Circuit.

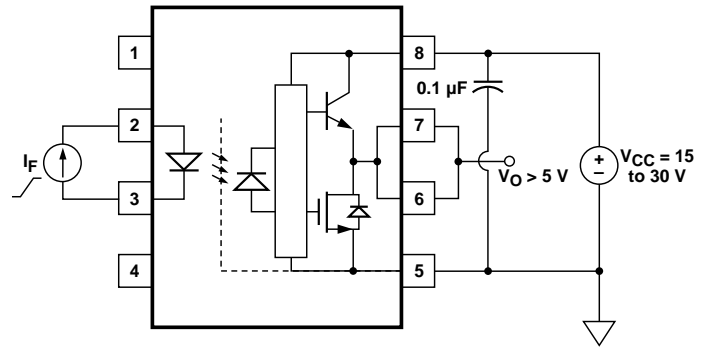

Figure 21.  $I_{FLH}$  Test Circuit.

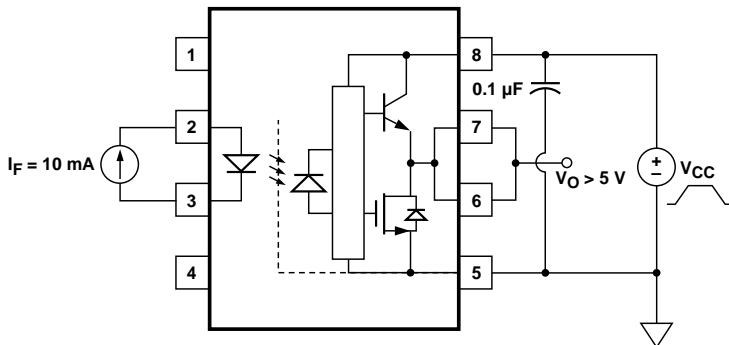

Figure 22. UVLO Test Circuit.

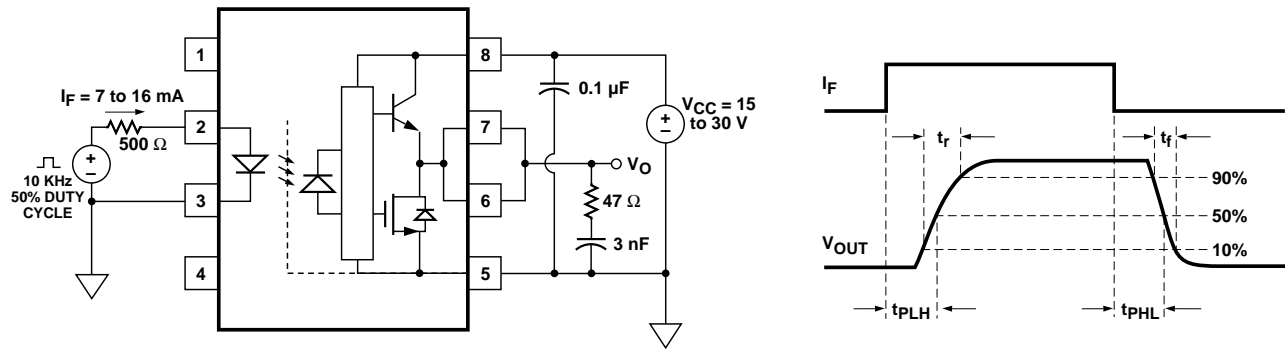

Figure 23.  $t_{PLH}$ ,  $t_{PHL}$ ,  $t_r$ , and  $t_f$  Test Circuit and Waveforms.

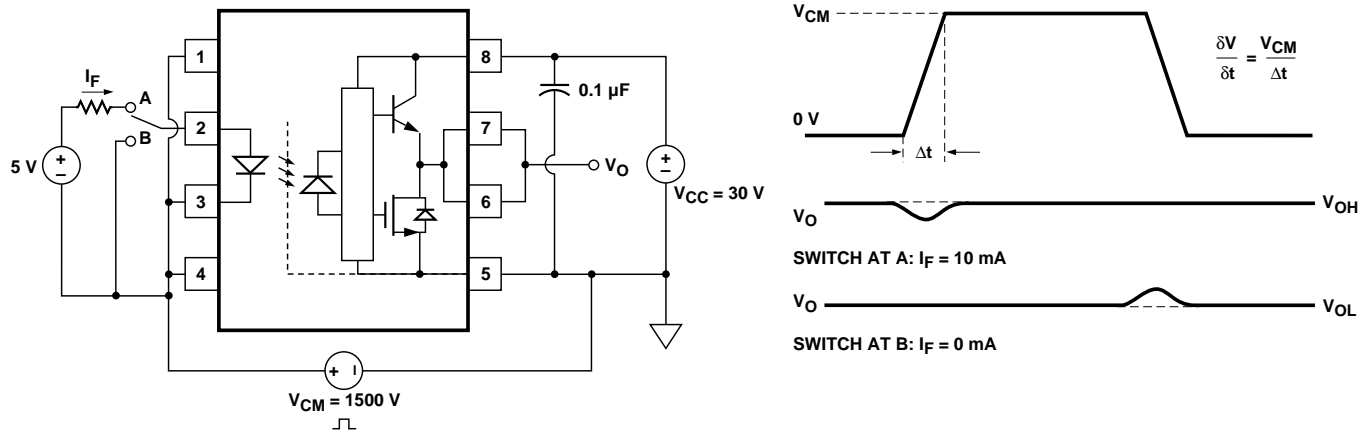

Figure 24. CMR Test Circuit and Waveforms.

## Applications Information

### Eliminating Negative IGBT Gate Drive

To keep the IGBT firmly off, the HCPL-3150 has a very low maximum  $V_{OL}$  specification of 1.0 V. The HCPL-3150 realizes this very low  $V_{OL}$  by using a DMOS transistor with 4  $\Omega$  (typical) on resistance in its pull down circuit. When the HCPL-3150 is in the low state,

the IGBT gate is shorted to the emitter by  $R_g + 4 \Omega$ . Minimizing  $R_g$  and the lead inductance from the HCPL-3150 to the IGBT gate and emitter (possibly by mounting the HCPL-3150 on a small PC board directly above the IGBT) can eliminate the need for negative IGBT gate drive in many applications as shown in Figure 25. Care should be taken with such a PC board design to avoid

routing the IGBT collector or emitter traces close to the HCPL-3150 input as this can result in unwanted coupling of transient signals into the HCPL-3150 and degrade performance. (If the IGBT drain must be routed near the HCPL-3150 input, then the LED should be reverse-biased when in the off state, to prevent the transient signals coupled from the IGBT drain from turning on the HCPL-3150.)

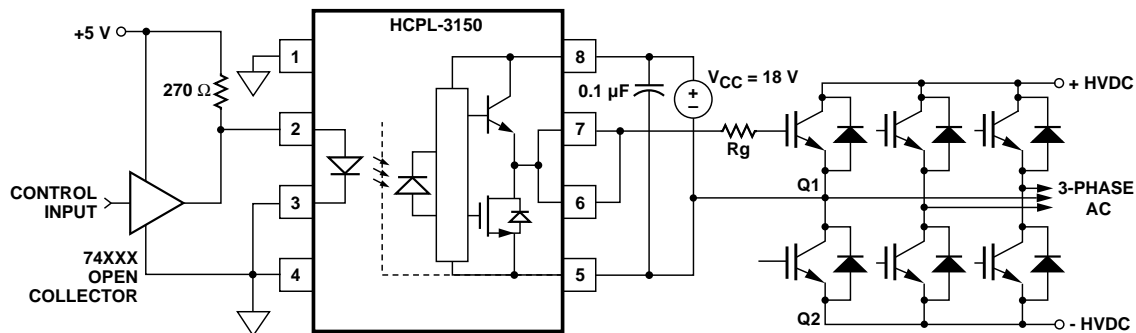

Figure 25. Recommended LED Drive and Application Circuit.

**Selecting the Gate Resistor (Rg) to Minimize IGBT Switching Losses.**

**Step 1: Calculate Rg Minimum From the IOL Peak Specification.** The IGBT and Rg in Figure 26 can be analyzed as a simple RC circuit with a voltage supplied by the HCPL-3150.

$$\begin{aligned}
 Rg &\geq \frac{(V_{CC} - V_{EE} - V_{OL})}{I_{OLPEAK}} \\
 &= \frac{(15\text{ V} - 5\text{ V} - 1.7\text{ V})}{0.6\text{ A}} \\
 &= 30.5\ \Omega
 \end{aligned}$$

The  $V_{OL}$  value of 2 V in the previous equation is a conservative value of  $V_{OL}$  at the peak current of 0.6 A (see Figure 6). At lower Rg values the voltage supplied by the HCPL-3150 is not an ideal voltage step. This results in lower peak currents (more margin) than predicted by this analysis. When negative gate drive is not used  $V_{EE}$  in the previous equation is equal to zero volts.

**Step 2: Check the HCPL-3150 Power Dissipation and Increase Rg if Necessary.** The HCPL-3150 total power dissipation ( $P_T$ ) is equal to the sum of the emitter power ( $P_E$ ) and the output power ( $P_O$ ):

$$\begin{aligned}
 P_T &= P_E + P_O \\
 P_E &= I_F \cdot V_F \cdot \text{Duty Cycle} \\
 P_O &= P_{O(BIAS)} + P_{O(SWITCHING)} \\
 &= I_{CC} \cdot (V_{CC} - V_{EE}) \\
 &\quad + E_{SW}(R_G, Q_G) \cdot f
 \end{aligned}$$

For the circuit in Figure 26 with  $I_F$  (worst case) = 16 mA, Rg = 30.5  $\Omega$ , Max Duty Cycle = 80%, Qg = 500 nC, f = 20 kHz and  $T_A$  max = 90°C:

$$\begin{aligned}
 P_E &= 16\text{ mA} \cdot 1.8\text{ V} \cdot 0.8 = 23\text{ mW} \\
 P_O &= 4.25\text{ mA} \cdot 20\text{ V} \\
 &\quad + 4.0\ \mu\text{J} \cdot 20\text{ kHz} \\
 &= 85\text{ mW} + 80\text{ mW} \\
 &= 165\text{ mW} \\
 &> 154\text{ mW } (P_{O(MAX)} \text{ @ } 90^\circ\text{C}) \\
 &= 250\text{ mW} - 20\text{C} \cdot 4.8\text{ mW/C}
 \end{aligned}$$

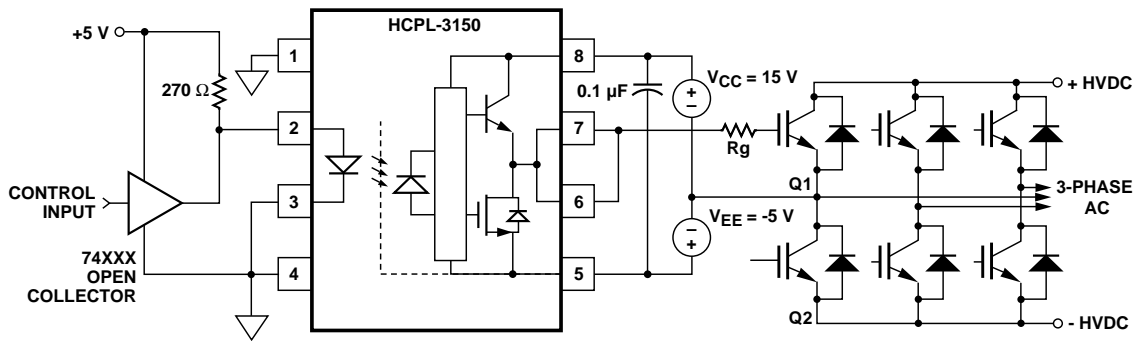

Figure 26. HCPL-3150 Typical Application Circuit with Negative IGBT Gate Drive.

$P_E$ Parameter	Description
$I_F$	LED Current
$V_F$	LED On Voltage
Duty Cycle	Maximum LED Duty Cycle

$P_O$ Parameter	Description
$I_{CC}$	Supply Current
$V_{CC}$	Positive Supply Voltage
$V_{EE}$	Negative Supply Voltage
$E_{SW}(R_G, Q_G)$	Energy Dissipated in the HCPL-3150 for each IGBT Switching Cycle (See Figure 27)
f	Switching Frequency

The value of 4.25 mA for  $I_{CC}$  in the previous equation was obtained by derating the  $I_{CC}$  max of 5 mA (which occurs at  $-40^{\circ}\text{C}$ ) to  $I_{CC}$  max at  $90^{\circ}\text{C}$  (see Figure 7).

Since  $P_O$  for this case is greater than  $P_{O(MAX)}$ ,  $R_g$  must be increased to reduce the HCPL-3150 power dissipation.

$$\begin{aligned} P_{O(SWITCHING\ MAX)} &= P_{O(MAX)} - P_{O(BIAS)} \\ &= 154\ mW - 85\ mW \\ &= 69\ mW \\ E_{SW(MAX)} &= \frac{P_{O(SWITCHING\ MAX)}}{f} \\ &= \frac{69\ mW}{20\ kHz} = 3.45\ \mu J \end{aligned}$$

For  $Q_g = 500\ \text{nC}$ , from Figure 27, a value of  $E_{SW} = 3.45\ \mu\text{J}$  gives a  $R_g = 41\ \Omega$ .

## Thermal Model

The steady state thermal model for the HCPL-3150 is shown in Figure 28. The thermal resistance values given in this model can be used to calculate the temperatures at each node for a given operating condition. As shown by the model, all heat generated flows through  $\theta_{CA}$  which raises the case temperature  $T_C$  accordingly. The value of  $\theta_{CA}$  depends on the conditions of the board design and is, therefore, determined by the designer. The value of  $\theta_{CA} = 83^{\circ}\text{C/W}$  was obtained from thermal measurements using a 2.5 x 2.5 inch PC board, with small traces (no ground plane), a single HCPL-3150 soldered into the center of the board and still air. The absolute maximum power dissipation derating specifications assume a  $\theta_{CA}$  value of  $83^{\circ}\text{C/W}$ .

From the thermal mode in Figure 28 the LED and detector IC junction temperatures can be expressed as:

$$T_{JE} = P_E \cdot (\theta_{LC} | | (\theta_{LD} + \theta_{DC}) + \theta_{CA}) + P_D \cdot \left( \frac{\theta_{LC} \cdot \theta_{DC}}{\theta_{LC} + \theta_{DC} + \theta_{LD}} + \theta_{CA} \right) + T_A$$

$$T_{JD} = P_E \cdot \left( \frac{\theta_{LC} \cdot \theta_{DC}}{\theta_{LC} + \theta_{DC} + \theta_{LD}} + \theta_{CA} \right) + P_D \cdot (\theta_{DC} | | (\theta_{LD} + \theta_{LC}) + \theta_{CA}) + T_A$$

Inserting the values for  $\theta_{LC}$  and  $\theta_{DC}$  shown in Figure 28 gives:

$$\begin{aligned} T_{JE} &= P_E \cdot (230^{\circ}\text{C/W} + \theta_{CA}) \\ &\quad + P_D \cdot (49^{\circ}\text{C/W} + \theta_{CA}) + T_A \\ T_{JD} &= P_E \cdot (49^{\circ}\text{C/W} + \theta_{CA}) \\ &\quad + P_D \cdot (104^{\circ}\text{C/W} + \theta_{CA}) + T_A \end{aligned}$$

For example, given  $P_E = 45\ \text{mW}$ ,  $P_O = 250\ \text{mW}$ ,  $T_A = 70^{\circ}\text{C}$  and  $\theta_{CA} = 83^{\circ}\text{C/W}$ :

$$\begin{aligned} T_{JE} &= P_E \cdot 313^{\circ}\text{C/W} + P_D \cdot 132^{\circ}\text{C/W} + T_A \\ &= 45\ \text{mW} \cdot 313^{\circ}\text{C/W} + 250\ \text{mW} \\ &\quad \cdot 132^{\circ}\text{C/W} + 70^{\circ}\text{C} = 117^{\circ}\text{C} \end{aligned}$$

$$\begin{aligned} T_{JD} &= P_E \cdot 132^{\circ}\text{C/W} + P_D \cdot 187^{\circ}\text{C/W} + T_A \\ &= 45\ \text{mW} \cdot 132^{\circ}\text{C/W} + 250\ \text{mW} \\ &\quad \cdot 187^{\circ}\text{C/W} + 70^{\circ}\text{C} = 123^{\circ}\text{C} \end{aligned}$$

$T_{JE}$  and  $T_{JD}$  should be limited to  $125^{\circ}\text{C}$  based on the board layout and part placement ( $\theta_{CA}$ ) specific to the application.

## LED Drive Circuit Considerations for Ultra High CMR Performance

Without a detector shield, the dominant cause of optocoupler CMR failure is capacitive coupling from the input side of the optocoupler, through the package, to the detector IC as

shown in Figure 29. The HCPL-3150 improves CMR performance by using a detector IC with an optically transparent Faraday shield, which diverts the capacitively coupled current away from the sensitive IC circuitry. However, this shield does not eliminate the capacitive coupling between the LED and optocoupler pins 5-8 as shown in Figure 30. This capacitive coupling causes perturbations in the LED current during common mode transients and becomes the major source of CMR failures for a shielded optocoupler. The main design objective of a high CMR LED drive circuit becomes keeping the LED in the proper state (on or off) during common mode transients. For example, the recommended application circuit (Figure 25), can achieve  $15\ \text{kV}/\mu\text{s}$  CMR while minimizing component complexity.

Techniques to keep the LED in the proper state are discussed in the next two sections.

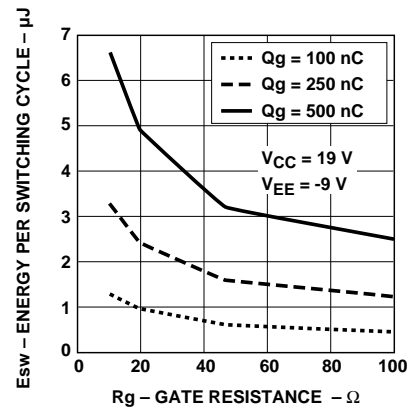

Figure 27. Energy Dissipated in the HCPL-3150 for Each IGBT Switching Cycle.

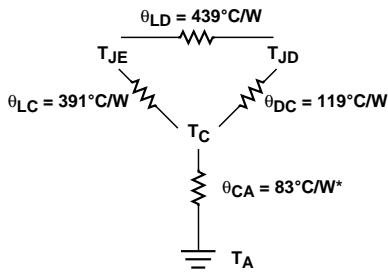

Figure 28. Thermal Model.

$T_{JE}$  = LED junction temperature  
 $T_{JD}$  = detector IC junction temperature  
 $T_C$  = case temperature measured at the center of the package bottom  
 $\theta_{LC}$  = LED-to-case thermal resistance  
 $\theta_{LD}$  = LED-to-detector thermal resistance  
 $\theta_{DC}$  = detector-to-case thermal resistance  
 $\theta_{CA}$  = case-to-ambient thermal resistance  
 \* $\theta_{CA}$  will depend on the board design and the placement of the part.

### CMR with the LED On ( $CMR_H$ )

A high CMR LED drive circuit must keep the LED on during common mode transients. This is achieved by overdriving the LED current beyond the input threshold so that it is not pulled below the threshold during a transient. A minimum LED current of 10 mA provides adequate margin over the maximum  $I_{FLH}$  of 5 mA to achieve 15 kV/ $\mu$ s CMR.

### CMR with the LED Off ( $CMR_L$ )

A high CMR LED drive circuit must keep the LED off ( $V_F \leq V_{F(OFF)}$ ) during common mode transients. For example, during a  $-dV_{CM}/dt$  transient in Figure 31, the current flowing through  $C_{LEDP}$  also flows through the  $R_{SAT}$  and  $V_{SAT}$  of the logic gate. As long as the low state voltage developed across the logic gate is less than  $V_{F(OFF)}$ , the LED will remain off and no common mode failure will occur.

The open collector drive circuit, shown in Figure 32, cannot keep the LED off during a  $+dV_{CM}/dt$  transient, since all the current flowing through  $C_{LEDN}$  must be supplied by the LED, and it is not recommended for applications requiring ultra high  $CMR_L$  performance. Figure 33 is an alternative drive circuit which, like the recommended application circuit (Figure 25), does achieve ultra high CMR performance by shunting the LED in the off state.

### Under Voltage Lockout Feature

The HCPL-3150 contains an under voltage lockout (UVLO) feature that is designed to protect the IGBT under fault conditions which cause the HCPL-3150 supply voltage (equivalent to the fully-charged IGBT gate voltage) to drop below a level necessary to keep the IGBT in a low resistance state. When the HCPL-3150 output is in the high state and the supply voltage drops below the HCPL-3150  $V_{UVLO}$  threshold ( $9.5 < V_{UVLO} < 12.0$ ), the

optocoupler output will go into the low state with a typical delay, UVLO Turn Off Delay, of 0.6  $\mu$ s. When the HCPL-3150 output is in the low state and the supply voltage rises above the HCPL-3150  $V_{UVLO+}$  threshold ( $11.0 < V_{UVLO+} < 13.5$ ), the optocoupler will go into the high state (assuming LED is "ON") with a typical delay, UVLO TURN On Delay, of 0.8  $\mu$ s.

### IPM Dead Time and Propagation Delay Specifications

The HCPL-3150 includes a Propagation Delay Difference (PDD) specification intended to help designers minimize "dead time" in their power inverter designs. Dead time is the time period during which both the high and low side power transistors (Q1 and Q2 in Figure 25) are off. Any overlap in Q1 and Q2 conduction will result in large currents flowing through the power devices from the high- to the low-voltage motor rails.

To minimize dead time in a given design, the turn on of LED2 should be delayed (relative to the

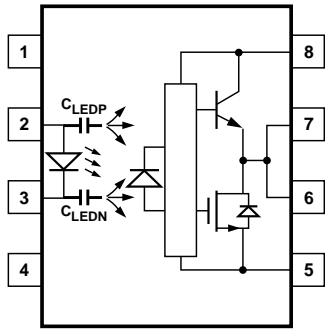

Figure 29. Optocoupler Input to Output Capacitance Model for Unshielded Optocouplers.

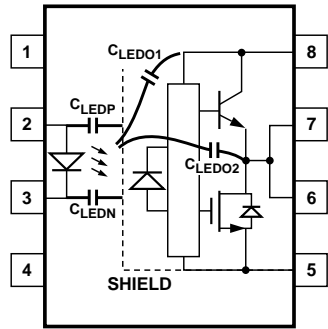

Figure 30. Optocoupler Input to Output Capacitance Model for Shielded Optocouplers.

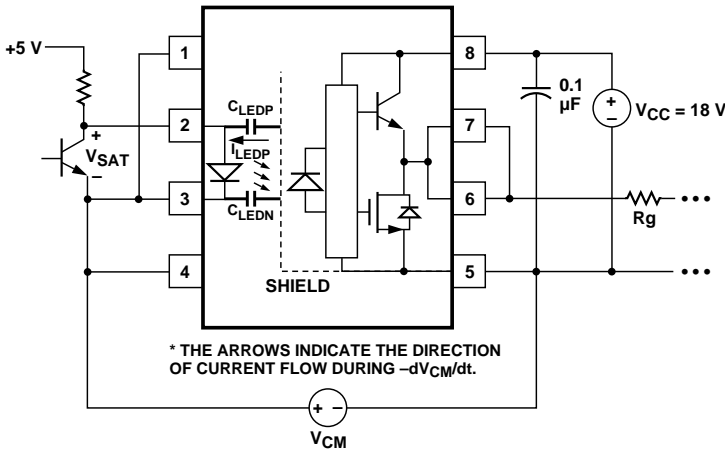

Figure 31. Equivalent Circuit for Figure 25 During Common Mode Transient.

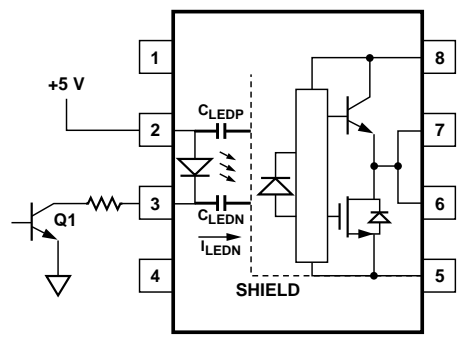

Figure 32. Not Recommended Open Collector Drive Circuit.

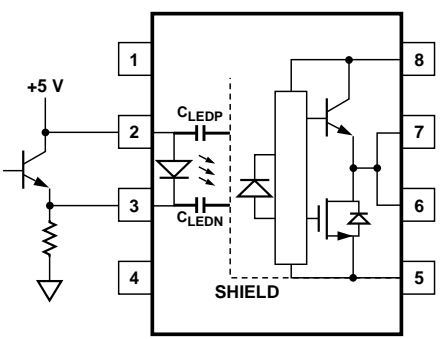

Figure 33. Recommended LED Drive Circuit for Ultra-High CMR.

turn off of LED1) so that under worst-case conditions, transistor Q1 has just turned off when transistor Q2 turns on, as shown in Figure 34. The amount of delay necessary to achieve this conditions is equal to the maximum value of the propagation delay difference specification,  $PDD_{MAX}$ , which is specified to be 350 ns over the operating temperature range of  $-40^{\circ}C$  to  $100^{\circ}C$ .

Delaying the LED signal by the maximum propagation delay difference ensures that the minimum dead time is zero, but it does not tell a designer what the maximum dead time will be. The

maximum dead time is equivalent to the difference between the maximum and minimum propagation delay difference specifications as shown in Figure 35. The maximum dead time for the HCPL-3150 is 700 ns ( $= 350 \text{ ns} - (-350 \text{ ns})$ ) over an operating temperature range of  $-40^{\circ}C$  to  $100^{\circ}C$ .

Note that the propagation delays used to calculate PDD and dead time are taken at equal temperatures and test conditions since the optocouplers under consideration are typically mounted in close proximity to each other and are switching identical IGBTs.

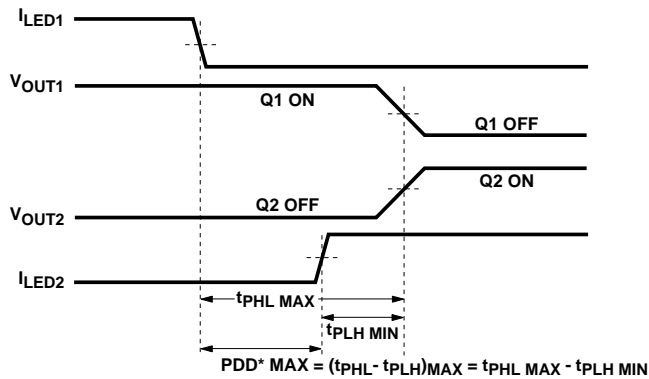

\*PDD = PROPAGATION DELAY DIFFERENCE  
 NOTE: FOR PDD CALCULATIONS THE PROPAGATION DELAYS ARE TAKEN AT THE SAME TEMPERATURE AND TEST CONDITIONS.

Figure 34. Minimum LED Skew for Zero Dead Time.

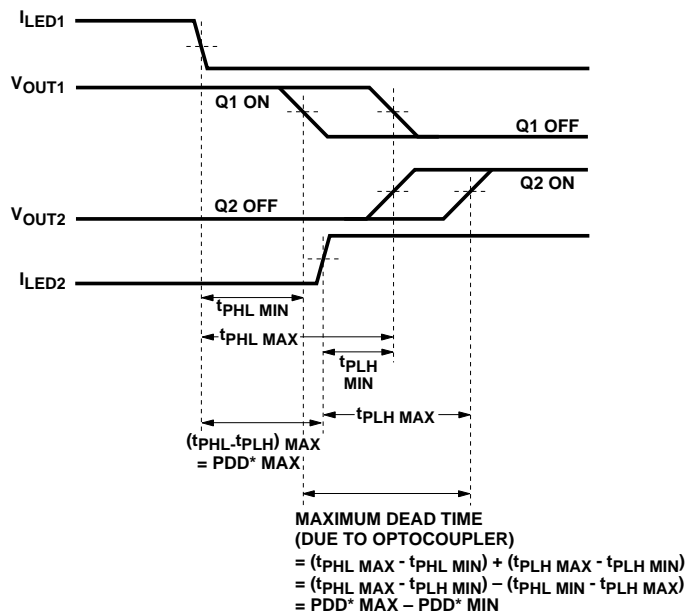

\*PDD = PROPAGATION DELAY DIFFERENCE  
 NOTE: FOR DEAD TIME AND PDD CALCULATIONS ALL PROPAGATION DELAYS ARE TAKEN AT THE SAME TEMPERATURE AND TEST CONDITIONS.

Figure 35. Waveforms for Dead Time.

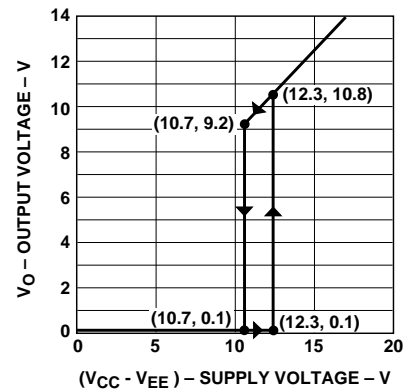

Figure 36. Under Voltage Lock Out.

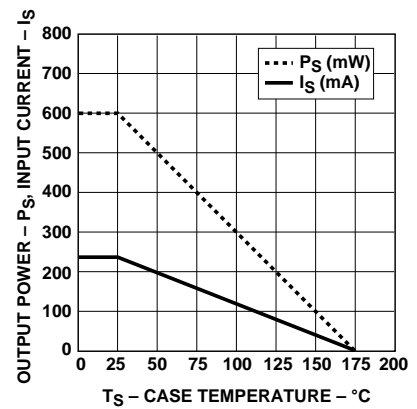

Figure 37. Thermal Derating Curve, Dependence of Safety Limiting Value with Case Temperature per VDE 0884.