

SANYO	No. 1402C	LA5550, 5550M
	LOW-VOLTAGE DC MOTOR SPEED CONTROLLER WITH LOGIC CIRCUIT	

Applications

The LA5550, 5550M are low-voltage (3V min.) DC motor speed control IC with bidirectional driver and logic circuit. Speed control, function control of DC motor for cassette tape recorder, tape deck, telephone answering machine.

Features

- . Wide operating voltage range: 1.8 to 8V.
- . Has a logic circuit which operates in such a manner as 2 logic inputs cause FF, REW, GOVERNOR, BRAKE mode to occur.
- . Easy to vary speed at the GOVERNOR mode.
- . Turning OFF the strobe pin causes little I_{CC} to flow (100uA).
- . Large starting torque.

Maximum Ratings at Ta=25°C

Maximum Supply Voltage	V_{CCmax}		8	V
Allowable Power Dissipation	$Pd\ max$	LA5550	1	W
		LA5550M	0.42	W
Maximum Motor Current	$I_m\ max$		1000	mA
Operating Temperature	$Topr$		-20 to +80	°C
Storage Temperature	$Tstg$		-40 to +150	°C

Operating Conditions at Ta=25°C

Supply Voltage Range	V_{CCop}		1.8 to 8	V
----------------------	------------	--	----------	---

LA5550
Package Dimensions 3006B-D16IC
(unit: mm)

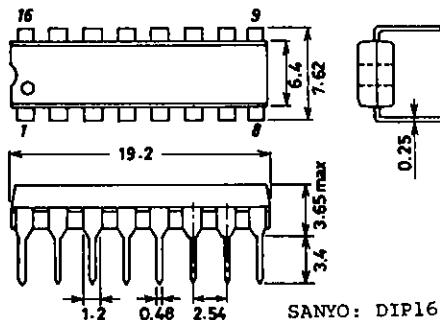

LA5550N
Package Dimensions 3036B-M20IC
(unit: mm)

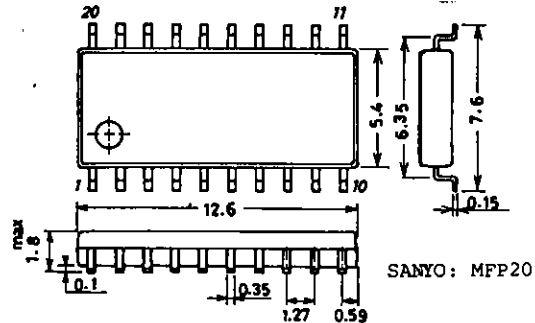

LA5550,5550M

Operating Characteristics at Ta=25°C

GOVERNOR Mode (G)		min	typ	max	unit
Reference Voltage	Vref	V _{CC} =3V, I _m =100mA	1.1	1.2	1.3 V
Quiescent Current Dissipation	I _d	V _{CC} =3V, motor open		8	15 mA
Shunt Ratio	K	V _{CC} =3V, I _m =50-150mA	45	50	55
Residual Voltage	V _{sat} (G)	V _{CC} =3V, I _m =200mA	0.27	0.5	V
Voltage Characteristic of Reference Voltage	$\frac{\Delta V_{ref}}{\Delta V}$	V _{CC} =1.8to8V, I _m =100mA	0.26	0.5	%/V
Voltage Characteristic of Shunt Ratio	$\frac{K/\Delta V}{K}$	V _{CC} =1.8to8V, I _m =50-150mA	0.45		%/V
Current Characteristic of Reference Voltage	$\frac{\Delta V_{ref}/\Delta I_m}{V_{ref}}$	V _{CC} =3V, I _m =20to200mA	0.05	0.1	%/mA
Current Characteristic of Shunt Ratio	$\frac{\Delta K/\Delta I_m}{K}$	V _{CC} =3V, I _m =50-100to150-200mA	-0.02		%/mA

FF Mode

Quiescent Current Dissipation	I _d (F)	V _{CC} =3V, motor open	18.5	23	mA
Residual Voltage	V _{sat} (F)	V _{CC} =3V, I _m =200mA	0.28	0.5	V

REW Mode

Quiescent Current Dissipation	I _d (R)	V _{CC} =3V, motor open	18.5	23	mA
Residual Voltage	V _{sat} (R)	V _{CC} =3V, I _m =200mA	0.30	0.5	V

STOP Mode

Quiescent Current Dissipation	I _d (S)	V _{CC} =3V (STB-ON)	26	30	mA
Strobe Current	I _{STB}	V _{CC} =3V (STB-OFF)	100	200	uA
Base Pull-in Current	I _{B1,2}	V _{CC} =3V, Modes other than BRAKE	3.8	4.4	5.8 mA

Equivalent Circuit Block Diagram

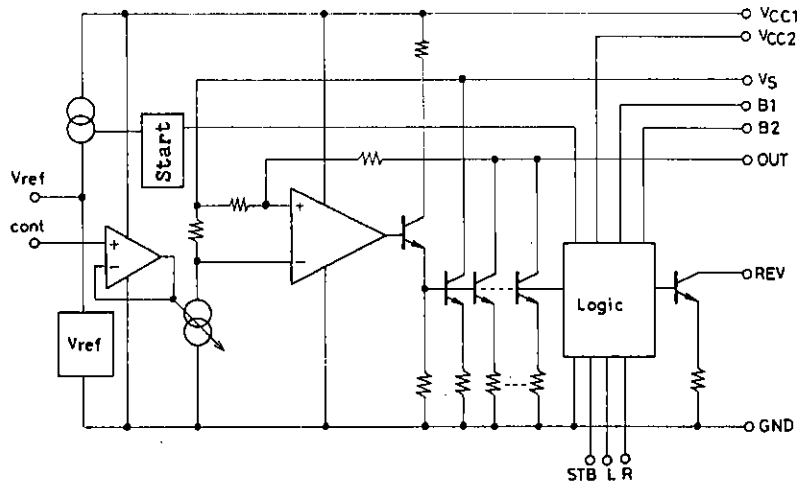

Pin Assignment

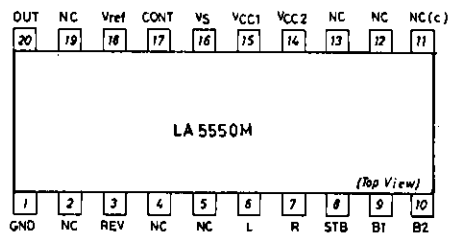
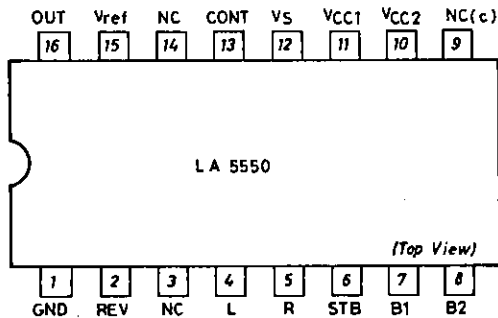

Sample Application Circuit (I)

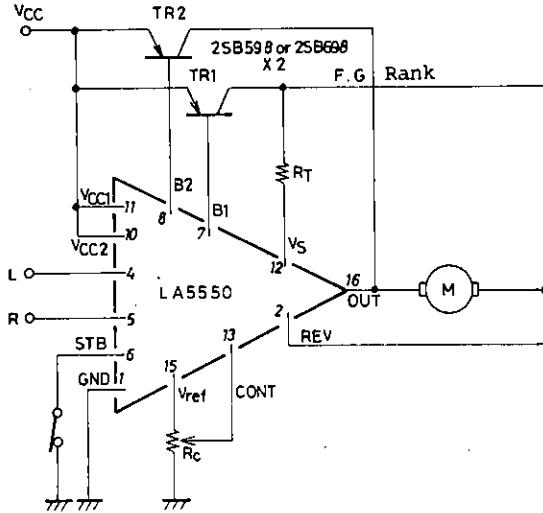

Assuming $R_T < K \cdot R_m$

Mode	L	R
High-speed FF	0	0
GOVERNOR FF	0	1
High-speed REW	1	0
BRAKE	1	1

0 : 0~0.3V
1 : 1.8V~VCC

Sample Application Circuit (II): Bidirectional Governor

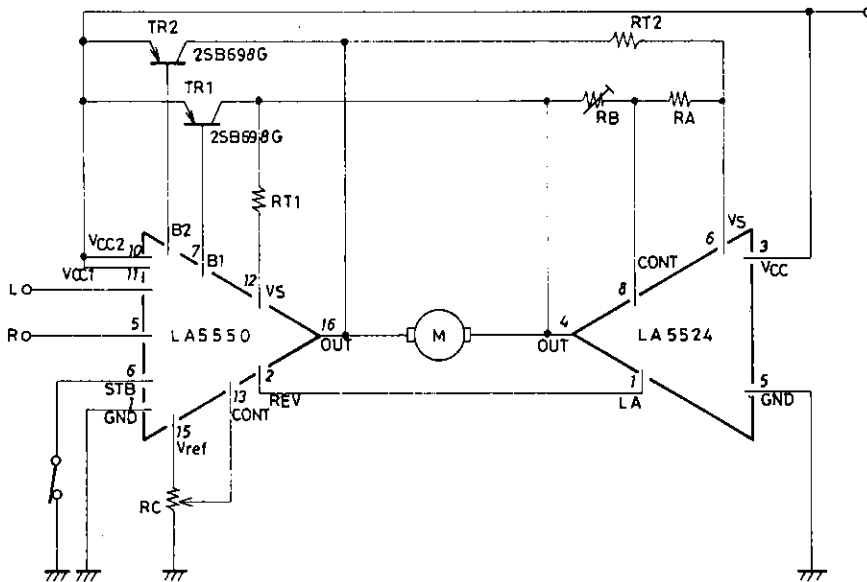

$R_A = 2.2k\Omega$
 $R_B = 50k\Omega$
 $R_C = 30k\Omega$

Turning OFF the STB pin causes $I_{CC} < 100\mu A$ (at 3V).

Mode	L	R
High-speed FF	0	0
FF control	0	1
REW control	1	0
BRAKE	1	1

- No products described or contained herein are intended for use in surgical implants, life-support systems, aerospace equipment, nuclear power control systems, vehicles, disaster/crime-prevention equipment and the like, the failure of which may directly or indirectly cause injury, death or property loss.
- Anyone purchasing any products described or contained herein for an above-mentioned use shall:
 - ① Accept full responsibility and indemnify and defend SANYO ELECTRIC CO., LTD., its affiliates, subsidiaries and distributors and all their officers and employees, jointly and severally, against any and all claims and litigation and all damages, cost and expenses associated with such use:
 - ② Not impose any responsibility for any fault or negligence which may be cited in any such claim or litigation on SANYO ELECTRIC CO., LTD., its affiliates, subsidiaries and distributors or any of their officers and employees jointly or severally.
- Information (including circuit diagrams and circuit parameters) herein is for example only; it is not guaranteed for volume production. SANYO believes information herein is accurate and reliable, but no guarantees are made or implied regarding its use or any infringements of intellectual property rights or other rights of third parties.