

LM185-1.2/LM285-1.2/LM385-1.2 Micropower Voltage Reference Diode

General Description

The LM185-1.2/LM285-1.2/LM385-1.2 are micropower 2-terminal band-gap voltage regulator diodes. Operating over a 10µA to 20mA current range, they feature exceptionally low dynamic impedance and good temperature stability. On-chip trimming is used to provide tight voltage tolerance. Since the LM185-1.2 band-gap reference uses only transistors and resistors, low noise and good long term stability result.

Careful design of the LM185-1.2 has made the device exceptionally tolerant of capacitive loading, making it easy to use in almost any reference application. The wide dynamic operating range allows its use with widely varying supplies with excellent regulation.

The extremely low power drain of the LM185-1.2 makes it useful for micropower circuitry. This voltage reference can be used to make portable meters, regulators or general purpose analog circuitry with battery life approaching shelf life.

Further, the wide operating current allows it to replace older references with a tighter tolerance part.

The LM185-1.2 is rated for operation over a -55°C to 125°C temperature range while the LM285-1.2 is rated -40°C to 85°C and the LM385-1.2 0°C to 70°C. The LM185-1.2/LM285-1.2 are available in a hermetic TO-46 package and the LM285-1.2/LM385-1.2 are also available in a low-cost TO-92 molded package, as well as SO and SOT-23. The LM185-1.2 is also available in a hermetic leadless chip carrier package.

Features

- ±1% and 2% initial tolerance
- Operating current of 10µA to 20mA
- 1Ω dynamic impedance
- Low temperature coefficient
- Low voltage reference—1.235V
- 2.5V device and adjustable device also available
- LM185-2.5 series and LM185 series, respectively

Connection Diagrams

T0-92
Plastic Package (Z)

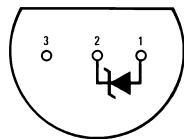

00551810

Bottom View

Order Number LM285Z-1.2,
LM285BXZ-1.2, LM285BYZ-1.2
LM385Z-1.2, LM385BZ-1.2
LM385BXZ-1.2 or LM385BYZ-1.2
See NS Package Number Z03A

SOT23

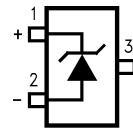

00551833

* Pin 3 is attached to the Die Attach Pad (DAP) and should be connected to Pin 2 or left floating.

Order Number LM385M3-1.2
See NS Package Number MF03A

Connection Diagrams (Continued)

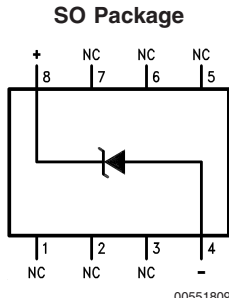

Order Number LM285M-1.2,
 LM285BXM-1.2, LM285BYM-1.2
 LM385M-1.2, LM385BM-1.2
 LM385BXM-1.2 or LM385BYM-1.2
 See NS Package Number M08A

**TO-46
 Metal Can Package (H)**

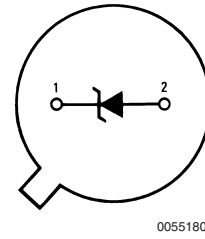

Bottom View

Order Number LM185H-1.2, LM185H-1.2/883,
 LM185BXH-1.2, LM185BYH-1.2
 LM285H-1.2 or LM285BXH-1.2
 See NS Package Number H02A

Absolute Maximum Ratings (Note 1)

If Military/Aerospace specified devices are required, please contact the National Semiconductor Sales Office/Distributors for availability and specifications.

(Note 2)

Reverse Current	30mA
Forward Current	10mA
Operating Temperature Range (Note 3)	
LM185-1.2	-55°C to +125°C
LM285-1.2	-40°C to +85°C
LM385-1.2	0°C to 70°C

Storage Temperature	-55°C to +150°C
Soldering Information	
TO-92 package: 10 sec.	260°C
TO-46 package: 10 sec.	300°C
SO and SOT Pkg.	
Vapor phase (60 sec.)	215°C
Infrared (15 sec.)	220°C
See AN-450 "Surface Mounting Methods and Their Effect on Product Reliability" for other methods of soldering surface mount devices.	

Electrical Characteristics (Note 4)

Parameter	Conditions	Typ	LM185-1.2 LM185BX-1.2 LM185BY-1.2 LM285-1.2 LM285BX-1.2 LM285BY-1.2		LM385B-1.2 LM385BX-1.2 LM385BY-1.2		LM385-1.2		Units (Limit)
			Tested Limit (Notes 5, 8)	Design Limit (Note 6)	Tested Limit (Note 5)	Design Limit (Note 6)	Tested Limit (Note 5)	Design Limit (Note 6)	
Reverse Breakdown Voltage	$T_A = 25^\circ\text{C}$, $10\mu\text{A} \leq I_R \leq 20\text{mA}$	1.235	1.223		1.223		1.205		V(Min)
			1.247		1.247		1.260		V(Max)
Minimum Operating Current		8	10	20	15	20	15	20	μA
	LM385M3-1.2						10	15	(Max)
Reverse Breakdown Voltage Change with Current	$10\mu\text{A} \leq I_R \leq 1\text{mA}$		1	1.5	1	1.5	1	1.5	mV (Max)
	$1\text{mA} \leq I_R \leq 20\text{mA}$		10	20	20	25	20	25	mV (Max)
Reverse Dynamic Impedance	$I_R = 100\mu\text{A}$, $f = 20\text{Hz}$	1							Ω
Wideband Noise (rms)	$I_R = 100\mu\text{A}$, $10\text{Hz} \leq f \leq 10\text{kHz}$	60							μV
Long Term Stability	$I_R = 100\mu\text{A}$, $T = 1000\text{Hr}$, $T_A = 25^\circ\text{C} \pm 0.1^\circ\text{C}$	20							ppm
Average Temperature Coefficient (Note 7)	$I_R = 100\mu\text{A}$								
	X Suffix		30		30				ppm/°C
	Y Suffix		50		50				ppm/°C
	All Others			150		150		150	ppm/°C (Max)

Note 1: Absolute Maximum Ratings indicate limits beyond which damage to the device may occur. Operating Ratings indicate conditions for which the device is intended to be functional, but do not guarantee specific performance limits. For guaranteed specifications and test conditions, see the Electrical Characteristics. The guaranteed specifications apply only for the test conditions listed.

Note 2: Refer to RETS185H-1.2 for military specifications.

Note 3: For elevated temperature operation, T_j max is:

LM185	150°C
LM285	125°C
LM385	100°C

Thermal Resistance	TO-92	TO-46	SO-8	SOT23
θ_{JA} (junction to ambient)	180°C/W (0.4" leads) 170°C/W (0.125" leads)	440°C/W	165°C/W	283°C/W
θ_{JC} (junction to case)	N/A	80°C/W	N/A	N/A

Note 4: Parameters identified with boldface type apply at temperature extremes. All other numbers apply at $T_A = T_J = 25^\circ\text{C}$.

Note 5: Guaranteed and 100% production tested.

Note 6: Guaranteed, but not 100% production tested. These limits are not used to calculate average outgoing quality levels.

Note 7: The average temperature coefficient is defined as the maximum deviation of reference voltage at all measured temperatures between the operating T_{MAX} and T_{MIN} , divided by $T_{MAX} - T_{MIN}$. The measured temperatures are -55°C , -40°C , 0°C , 25°C , 70°C , 85°C , 125°C .

Note 8: A military RETS electrical specification is available on request.

Typical Performance Characteristics

Reverse Characteristics

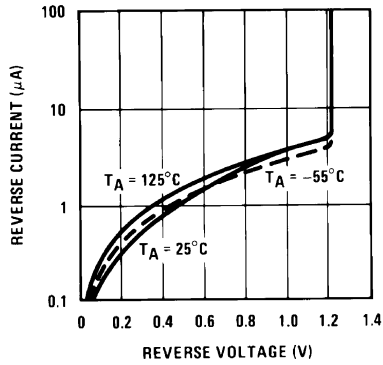

00551813

Reverse Characteristics

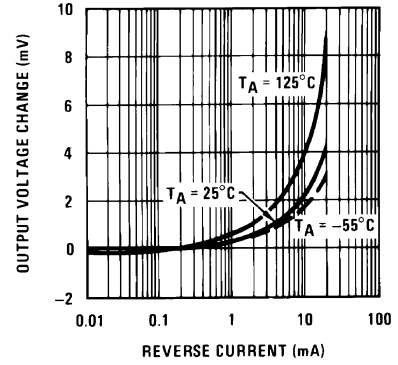

00551814

Forward Characteristics

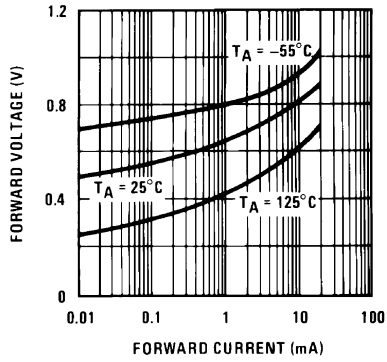

00551815

Temperature Drift of 3 Representative Units

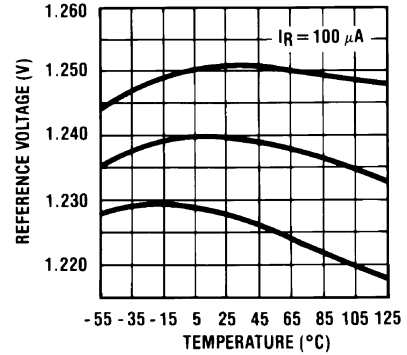

00551816

Reverse Dynamic Impedance

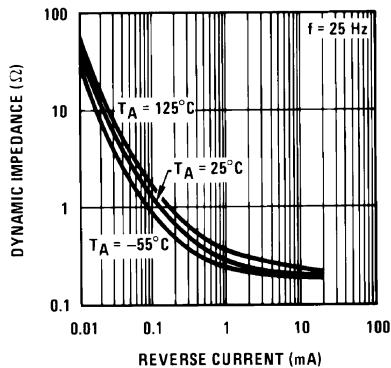

00551817

Reverse Dynamic Impedance

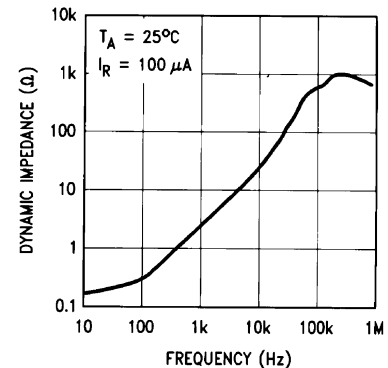

00551818

Typical Performance Characteristics (Continued)

Noise Voltage

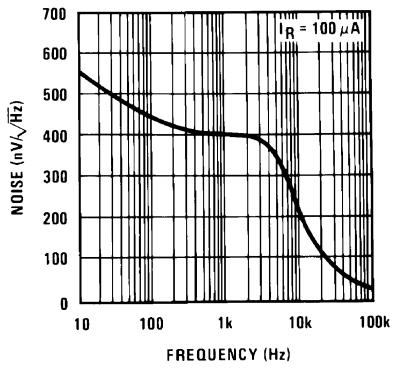

00551819

Filtered Output Noise

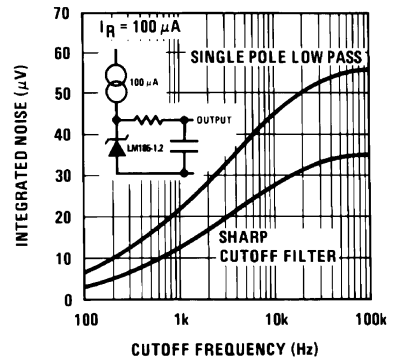

00551820

Response Time

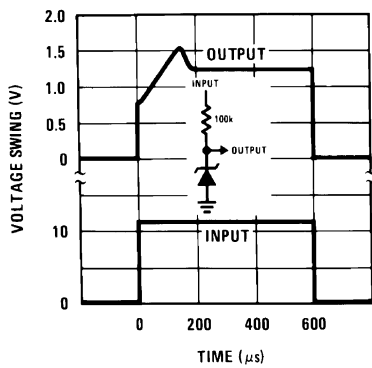

00551821

Typical Applications

Wide Input Range Reference

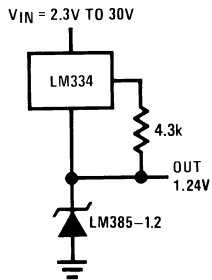

00551808

Reference from 1.5V Battery

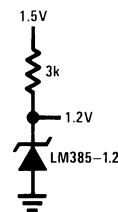

00551823

Micropower Reference from 9V Battery

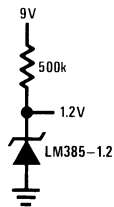

00551822

Typical Applications (Continued)

Micropower* 5V Regulator

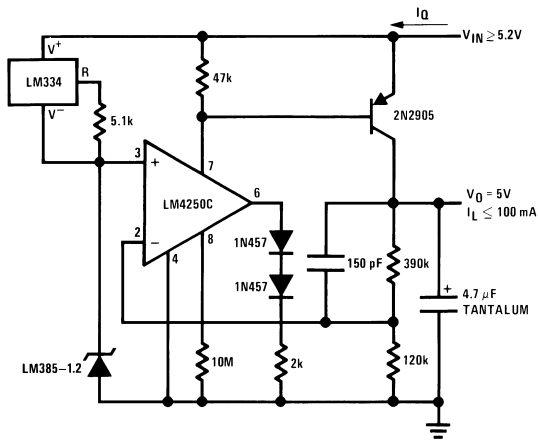

* $I_Q \approx 30\mu\text{A}$

00551824

Micropower* 10V Reference

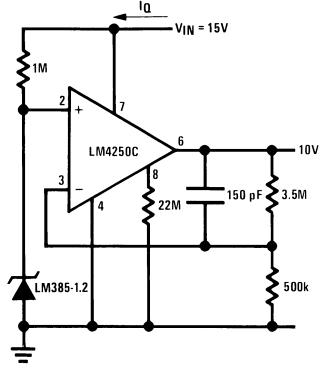

* $I_Q \approx 20\mu\text{A}$ standby current

00551825

Precision 1μA to 1mA Current Sources

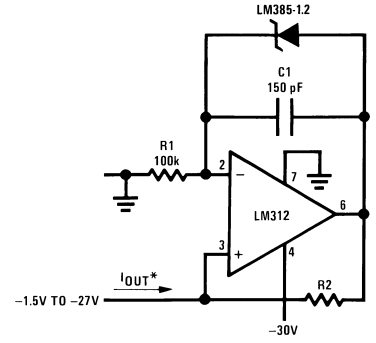

00551826

$$*I_{OUT} = \frac{1.23V}{R2}$$

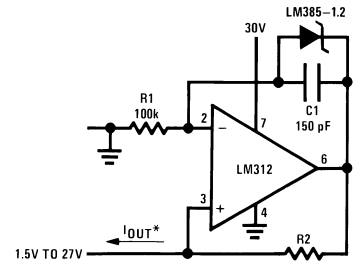

00551827

Typical Applications (Continued)

METER THERMOMETERS

0°C–100°C Thermometer

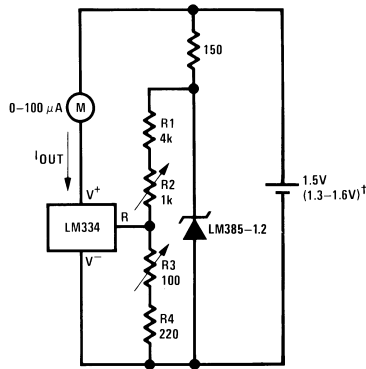

00551828

Calibration

1. Short LM385-1.2, adjust R3 for $I_{OUT} = \text{temp at } 1\mu\text{A}/^\circ\text{K}$
2. Remove short, adjust R2 for correct reading in centigrade $^\circ\text{C}$ at $1.3\text{V} \approx 500\mu\text{A}$
 I_Q at $1.6\text{V} \approx 2.4\text{mA}$

Lower Power Thermometer

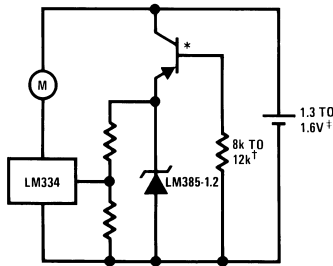

00551829

*2N3638 or 2N2907 select for inverse $H_{FE} \approx 5$

†Select for operation at 1.3V

‡ $I_Q \approx 600\mu\text{A}$ to $900\mu\text{A}$

0°F–50°F Thermometer

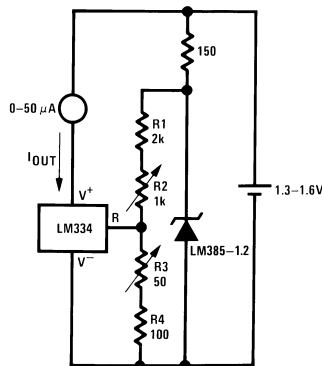

00551830

Calibration

1. Short LM385-1.2, adjust R3 for $I_{OUT} = \text{temp at } 1.8\mu\text{A}/^\circ\text{K}$
2. Remove short, adjust R2 for correct reading in $^\circ\text{F}$

Typical supply current $50\mu\text{A}$

Micropower Thermocouple Cold Junction Compensator

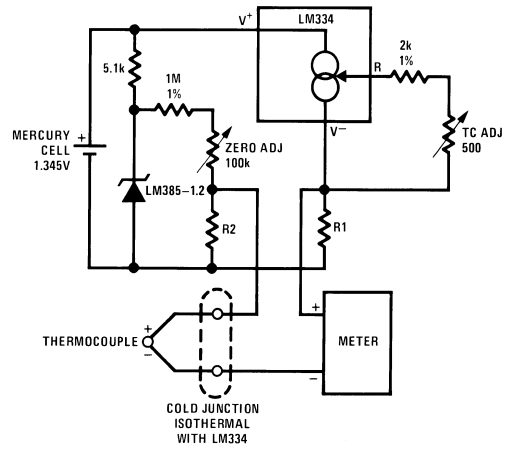

00551831

Adjustment Procedure

1. Adjust TC ADJ pot until voltage across R1 equals Kelvin temperature multiplied by the thermocouple Seebeck coefficient.
2. Adjust zero ADJ pot until voltage across R2 equals the thermocouple Seebeck coefficient multiplied by 273.2.

Thermocouple Type	Seebeck Coefficient ($\mu\text{V}/^\circ\text{C}$)	R1 (Ω)	R2 (Ω)	Voltage Across R1 @ 25°C (mV)	Voltage Across R2 (mV)
J	52.3	523	24k	15.60	14.32
T	42.8	432	1k	12.77	11.78
K	40.8	412	53 Ω	12.17	11.17
S	6.4	63.4	450 Ω	1.908	1.766

Typical Applications (Continued)

Centigrade Thermometer

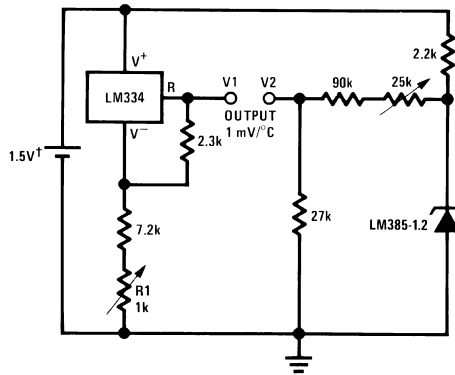

00551801

Calibration

1. Adjust R1 so that V1 = temp at 1mV/°K
 2. Adjust V2 to 273.2mV
- I_Q for 1.3V to 1.6V battery voltage = 50 μ A to 150 μ A

Schematic Diagram

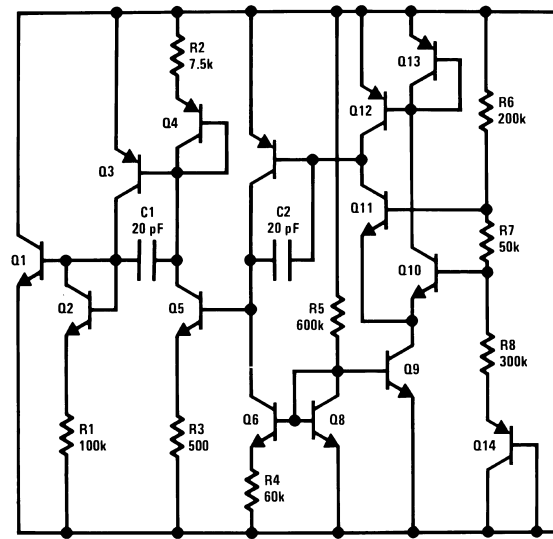

00551807

Physical Dimensions inches (millimeters) unless otherwise noted

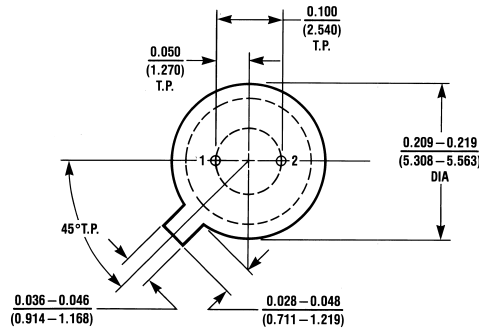
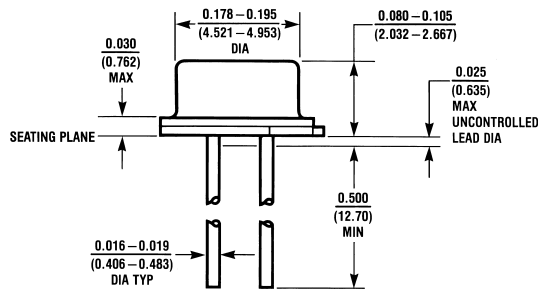

H02A (REV C)

TO-46 Metal Can Package (H)

Order Number LM185H-1.2, LM185H-1.2/883, LM185BXH-1.2, LM185BYH-1.2, LM285H-1.2, or LM285BXH-1.2
NS Package Number H02A

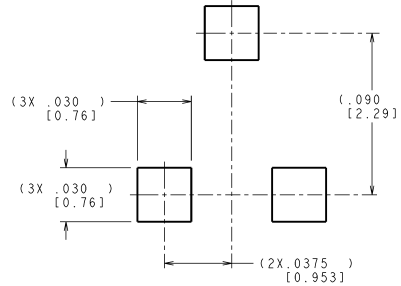
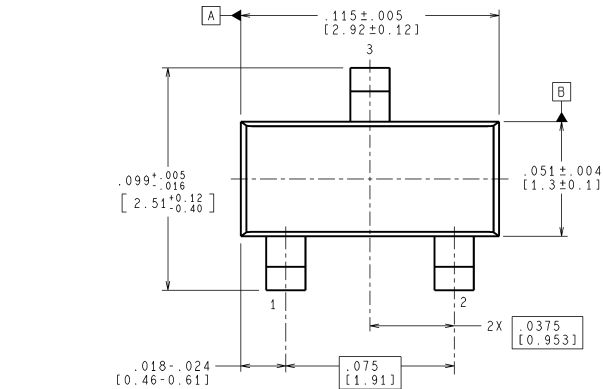

RECOMENDED LAND PATTERN

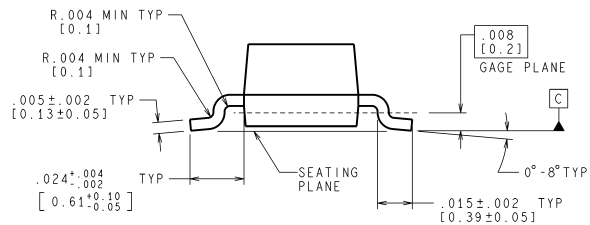
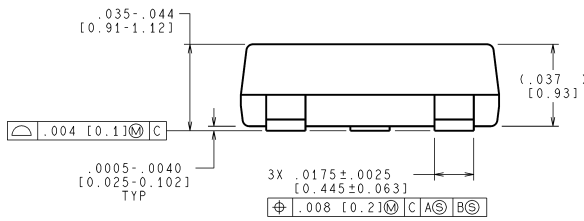

CONTROLLING DIMENSION IS INCH
VALUES IN [] ARE MILLIMETERS

MF03A (Rev B)

SOT-23 Package (M3)
Order Number LM385M3-1.2
NS Package Number MF03A

Physical Dimensions inches (millimeters) unless otherwise noted (Continued)

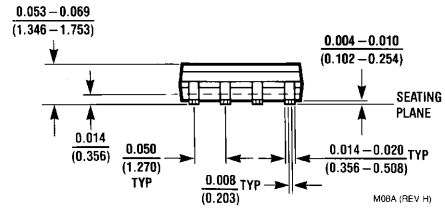
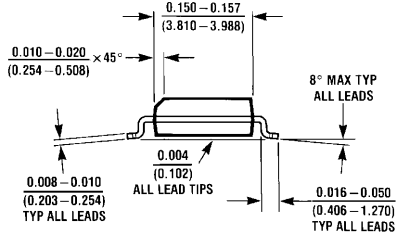
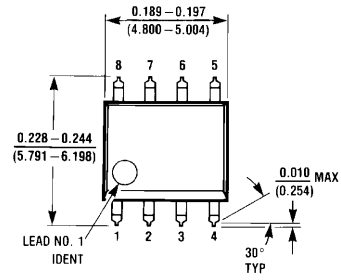

Small Outline (SO-8) Package
Order Number LM285M-1.2, LM285BXM-1.2, LM285BYM-1.2
LM385M-1.2, LM385BM-1.2, LM385BXM-1.2, LM385BYM-1.2
NS Package Number M08A

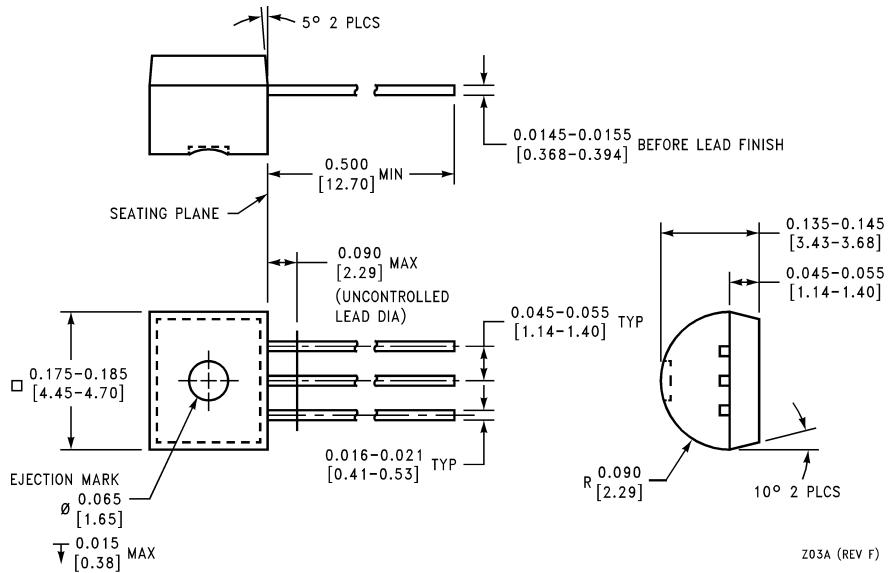

TO-92 Plastic Package (Z)
Order Number LM285Z-1.2, LM285BXZ-1.2
LM285BYZ-1.2, LM385Z-1.2, LM385BZ-1.2
LM385BXZ-1.2 or LM385BYZ-1.2
NS Package Number Z03A

Notes

National does not assume any responsibility for use of any circuitry described, no circuit patent licenses are implied and National reserves the right at any time without notice to change said circuitry and specifications.

For the most current product information visit us at www.national.com.

LIFE SUPPORT POLICY

NATIONAL'S PRODUCTS ARE NOT AUTHORIZED FOR USE AS CRITICAL COMPONENTS IN LIFE SUPPORT DEVICES OR SYSTEMS WITHOUT THE EXPRESS WRITTEN APPROVAL OF THE PRESIDENT AND GENERAL COUNSEL OF NATIONAL SEMICONDUCTOR CORPORATION. As used herein:

1. Life support devices or systems are devices or systems which, (a) are intended for surgical implant into the body, or (b) support or sustain life, and whose failure to perform when properly used in accordance with instructions for use provided in the labeling, can be reasonably expected to result in a significant injury to the user.
2. A critical component is any component of a life support device or system whose failure to perform can be reasonably expected to cause the failure of the life support device or system, or to affect its safety or effectiveness.

BANNED SUBSTANCE COMPLIANCE

National Semiconductor certifies that the products and packing materials meet the provisions of the Customer Products Stewardship Specification (CSP-9-111C2) and the Banned Substances and Materials of Interest Specification (CSP-9-111S2) and contain no "Banned Substances" as defined in CSP-9-111S2.



National Semiconductor
Americas Customer
Support Center
Email: new.feedback@nsc.com
Tel: 1-800-272-9959

National Semiconductor
Europe Customer Support Center
Fax: +49 (0) 180-530 85 86
Email: europe.support@nsc.com
Deutsch Tel: +49 (0) 69 9508 6208
English Tel: +44 (0) 870 24 0 2171
Français Tel: +33 (0) 1 41 91 8790

National Semiconductor
Asia Pacific Customer
Support Center
Email: ap.support@nsc.com

National Semiconductor
Japan Customer Support Center
Fax: 81-3-5639-7507
Email: jpn.feedback@nsc.com
Tel: 81-3-5639-7560