

LM339, LM239, LM2901, LM2901V, NCV2901, MC3302

Single Supply Quad Comparators

These comparators are designed for use in level detection, low-level sensing and memory applications in consumer, automotive, and industrial electronic applications.

- Single or Split Supply Operation
- Low Input Bias Current: 25 nA (Typ)
- Low Input Offset Current: ± 5.0 nA (Typ)
- Low Input Offset Voltage
- Input Common Mode Voltage Range to Gnd
- Low Output Saturation Voltage: 130 mV (Typ) @ 4.0 mA
- TTL and CMOS Compatible
- ESD Clamps on the Inputs Increase Reliability without Affecting Device Operation

MAXIMUM RATINGS

Rating	Symbol	Value	Unit
Power Supply Voltage LM239/LM339/LM2901, V MC3302	V_{CC}	+36 or ± 18 +30 or ± 15	Vdc
Input Differential Voltage Range LM239/LM339/LM2901, V MC3302	V_{IDR}	36 30	Vdc
Input Common Mode Voltage Range	V_{ICMR}	-0.3 to V_{CC}	Vdc
Output Short Circuit to Ground (Note 1)	I_{SC}	Continuous	
Power Dissipation @ $T_A = 25^\circ\text{C}$ Plastic Package Derate above 25°C	P_D $1/R_{\theta JA}$	1.0 8.0	W mW/ $^\circ\text{C}$
Junction Temperature	T_J	150	$^\circ\text{C}$
Operating Ambient Temperature Range LM239 MC3302 LM2901 LM2901V, NCV2901 LM339	T_A	-25 to +85 -40 to +85 -40 to +105 -40 to +125 0 to +70	$^\circ\text{C}$
Storage Temperature Range	T_{stg}	-65 to +150	$^\circ\text{C}$

1. The maximum output current may be as high as 20 mA, independent of the magnitude of V_{CC} . Output short circuits to V_{CC} can cause excessive heating and eventual destruction.



ON Semiconductor®

<http://onsemi.com>

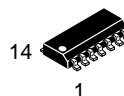

SO-14
D SUFFIX
CASE 751A

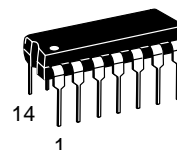

PDIP-14
N, P SUFFIX
CASE 646

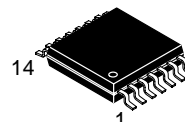

TSSOP-14
DTB SUFFIX
CASE 948G

PIN CONNECTIONS

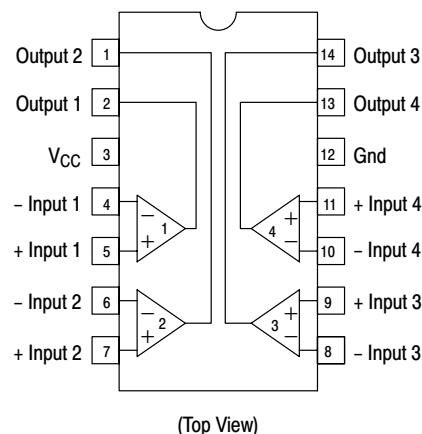

ORDERING INFORMATION

See detailed ordering and shipping information in the package dimensions section on page 6 of this data sheet.

DEVICE MARKING INFORMATION

See general marking information in the device marking section on page 6 of this data sheet.

LM339, LM239, LM2901, LM2901V, NCV2901, MC3302

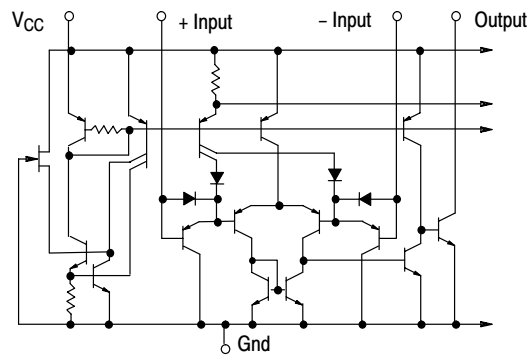

NOTE: Diagram shown is for 1 comparator.

Figure 1. Circuit Schematic

ELECTRICAL CHARACTERISTICS (V_{CC} = +5.0 Vdc, T_A = +25°C, unless otherwise noted)

Characteristic	Symbol	LM239/339			LM2901/2901V/ NCV2901			MC3302			Unit
		Min	Typ	Max	Min	Typ	Max	Min	Typ	Max	
Input Offset Voltage (Note 3)	V _{IO}	-	±2.0	±5.0	-	±2.0	±7.0	-	±3.0	±20	mVdc
Input Bias Current (Notes 3, 4) (Output in Analog Range)	I _{IB}	-	25	250	-	25	250	-	25	500	nA
Input Offset Current (Note 3)	I _{IO}	-	±5.0	±50	-	±5.0	±50	-	±3.0	±100	nA
Input Common Mode Voltage Range	V _{ICMR}	0	-	V _{CC} -1.5	0	-	V _{CC} -1.5	0	-	V _{CC} -1.5	V
Supply Current R _L = ∞ (For All Comparators) R _L = ∞, V _{CC} = 30 Vdc	I _{CC}	-	0.8 1.0	2.0 2.5	-	0.8 1.0	2.0 2.5	-	0.8 1.0	2.0 2.5	mA
Voltage Gain R _L ≥ 15 kΩ, V _{CC} = 15 Vdc	A _{VOL}	50	200	-	25	100	-	25	100	-	V/mV
Large Signal Response Time V _I = TTL Logic Swing, V _{ref} = 1.4 Vdc, V _{RL} = 5.0 Vdc, R _L = 5.1 kΩ	-	-	300	-	-	300	-	-	300	-	ns
Response Time (Note 5) V _{RL} = 5.0 Vdc, R _L = 5.1 kΩ	-	-	1.3	-	-	1.3	-	-	1.3	-	μs
Output Sink Current V _I (-) ≥ +1.0 Vdc, V _I (+) = 0, V _O ≤ 1.5 Vdc	I _{Sink}	6.0	16	-	6.0	16	-	6.0	16	-	mA
Saturation Voltage V _I (-) ≥ +1.0 Vdc, V _I (+) = 0, I _{Sink} ≤ 4.0 mA	V _{sat}	-	130	400	-	130	400	-	130	500	mV
Output Leakage Current V _I (+) ≥ +1.0 Vdc, V _I (-) = 0, V _O = +5.0 Vdc	I _{OL}	-	0.1	-	-	0.1	-	-	0.1	-	nA

- (LM239) T_{low} = -25°C, T_{high} = +85°C
(LM339) T_{low} = 0°C, T_{high} = +70°C
(MC3302) T_{low} = -40°C, T_{high} = +85°C
(LM2901) T_{low} = -40°C, T_{high} = +105°C
(LM2901V & NCV2901) T_{low} = -40°C, T_{high} = +125°C
NCV2901 is qualified for automotive use.
- At the output switch point, V_O ≈ 1.4 Vdc, R_S ≤ 100 Ω 5.0 Vdc ≤ V_{CC} ≤ 30 Vdc, with the inputs over the full common mode range (0 Vdc to V_{CC} - 1.5 Vdc).
- The bias current flows out of the inputs due to the PNP input stage. This current is virtually constant, independent of the output state.
- The response time specified is for a 100 mV input step with 5.0 mV overdrive. For larger signals, 300 ns is typical.

LM339, LM239, LM2901, LM2901V, NCV2901, MC3302

PERFORMANCE CHARACTERISTICS ($V_{CC} = +5.0$ Vdc, $T_A = T_{low}$ to T_{high} [Note 6])

Characteristic	Symbol	LM239/339			LM2901/2901V/ NCV2901			MC3302			Unit
		Min	Typ	Max	Min	Typ	Max	Min	Typ	Max	
Input Offset Voltage (Note 7)	V_{IO}	-	-	± 9.0	-	-	± 15	-	-	± 40	mVdc
Input Bias Current (Notes 7, 8) (Output in Analog Range)	I_{IB}	-	-	400	-	-	500	-	-	1000	nA
Input Offset Current (Note 7)	I_{IO}	-	-	± 150	-	-	± 200	-	-	± 300	nA
Input Common Mode Voltage Range	V_{ICMR}	0	-	$V_{CC} - 2.0$	0	-	$V_{CC} - 2.0$	0	-	$V_{CC} - 2.0$	V
Saturation Voltage $V_{I(-)} \geq +1.0$ Vdc, $V_{I(+)} = 0$, $I_{sink} \leq 4.0$ mA	V_{sat}	-	-	700	-	-	700	-	-	700	mV
Output Leakage Current $V_{I(+)} \geq +1.0$ Vdc, $V_{I(-)} = 0$, $V_O = 30$ Vdc	I_{OL}	-	-	1.0	-	-	1.0	-	-	1.0	μ A
Differential Input Voltage All $V_I \geq 0$ Vdc	V_{ID}	-	-	V_{CC}	-	-	V_{CC}	-	-	V_{CC}	Vdc

- (LM239) $T_{low} = -25^\circ\text{C}$, $T_{high} = +85^\circ\text{C}$
(LM339) $T_{low} = 0^\circ\text{C}$, $T_{high} = +70^\circ\text{C}$
(MC3302) $T_{low} = -40^\circ\text{C}$, $T_{high} = +85^\circ\text{C}$
(LM2901) $T_{low} = -40^\circ\text{C}$, $T_{high} = +105^\circ\text{C}$
(LM2901V & NCV2901) $T_{low} = -40^\circ\text{C}$, $T_{high} = +125^\circ\text{C}$
NCV2901 is qualified for automotive use.
- At the output switch point, $V_O = 1.4$ Vdc, $R_S \leq 100 \Omega$ 5.0 Vdc $\leq V_{CC} \leq 30$ Vdc, with the inputs over the full common mode range (0 Vdc to $V_{CC} - 1.5$ Vdc).
- The bias current flows out of the inputs due to the PNP input stage. This current is virtually constant, independent of the output state.
- The response time specified is for a 100 mV input step with 5.0 mV overdrive. For larger signals, 300 ns is typical.

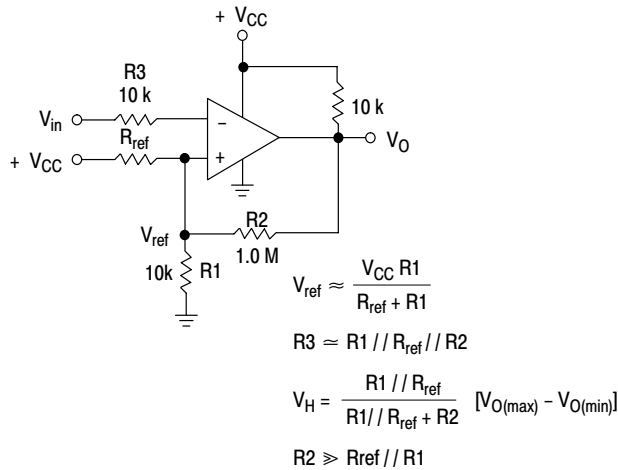

Figure 2. Inverting Comparator with Hysteresis

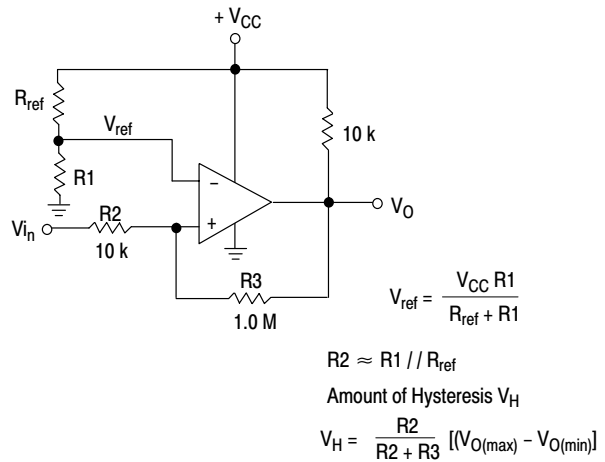

Figure 3. Noninverting Comparator with Hysteresis

Typical Characteristics

($V_{CC} = 15 \text{ Vdc}$, $T_A = +25^\circ\text{C}$ (each comparator) unless otherwise noted.)

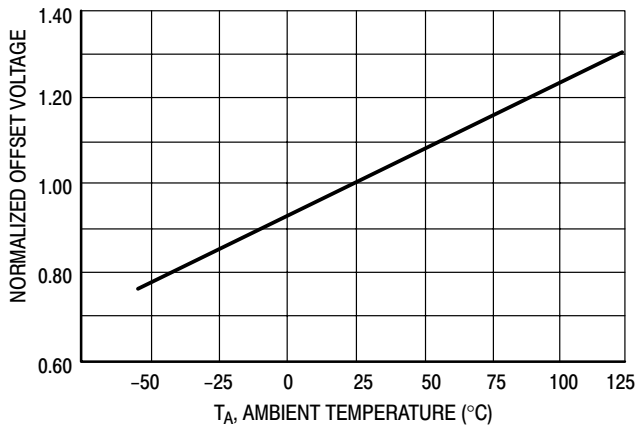

Figure 4. Normalized Input Offset Voltage

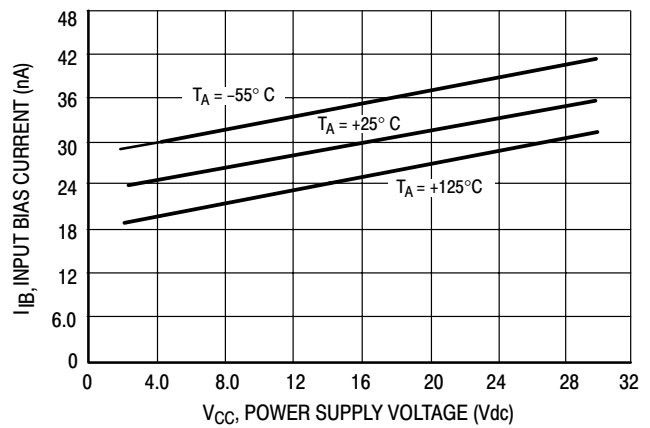

Figure 5. Input Bias Current

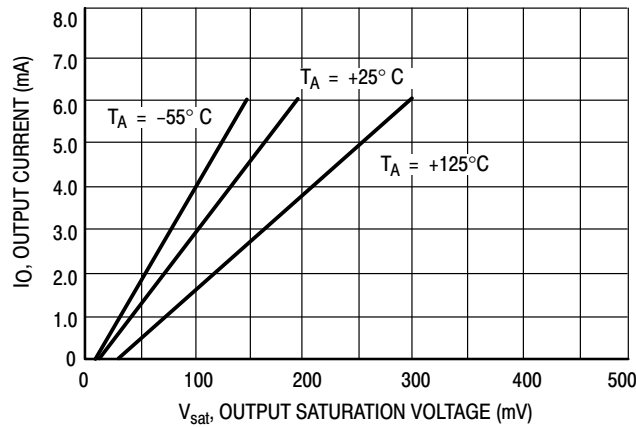
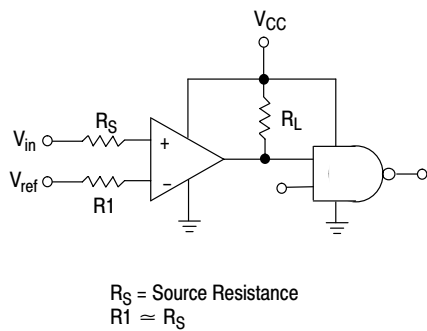

Figure 6. Output Sink Current versus Output Saturation Voltage



Logic	Device	V_{CC} (V)	R_L (k Ω)
CMOS	1/4 MC14001	+15	100
TTL	1/4 MC7400	+5.0	10

Figure 7. Driving Logic

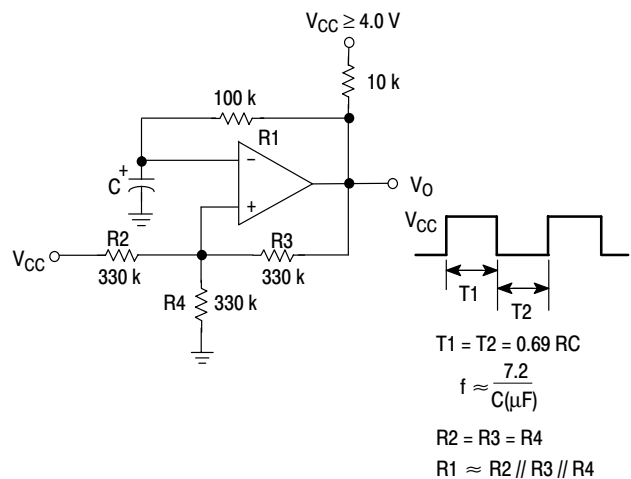

Figure 8. Squarewave Oscillator

APPLICATIONS INFORMATION

These quad comparators feature high gain, wide bandwidth characteristics. This gives the device oscillation tendencies if the outputs are capacitively coupled to the inputs via stray capacitance. This oscillation manifests itself during output transitions (V_{OL} to V_{OH}). To alleviate this situation input resistors $< 10\text{ k}\Omega$ should be used. The

addition of positive feedback ($< 10\text{ mV}$) is also recommended. It is good design practice to ground all unused input pins.

Differential input voltages may be larger than supply voltages without damaging the comparator's inputs. Voltages more negative than -300 mV should not be used.

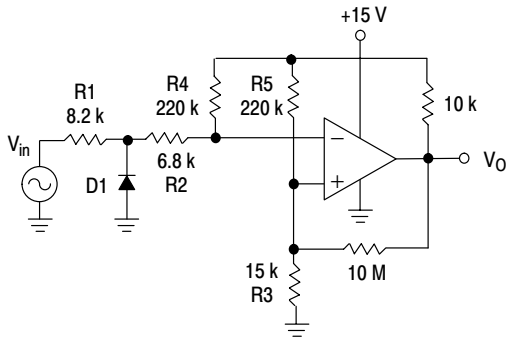

D1 prevents input from going negative by more than 0.6 V.

$$R1 + R2 = R3$$

$$R3 \leq \frac{R5}{10} \text{ for small error in zero crossing}$$

Figure 9. Zero Crossing Detector (Single Supply)

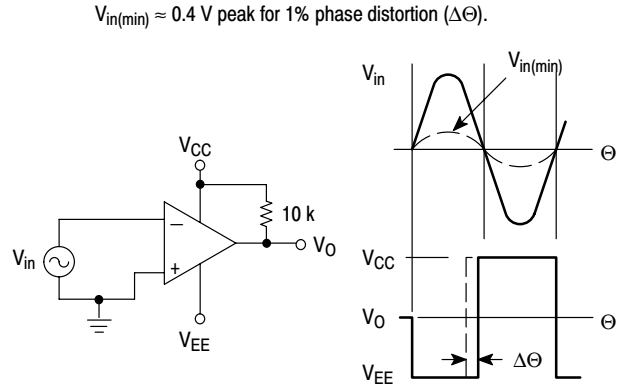

$V_{in(min)} \approx 0.4\text{ V}$ peak for 1% phase distortion ($\Delta\Theta$).

Figure 10. Zero Crossing Detector (Split Supplies)

LM339, LM239, LM2901, LM2901V, NCV2901, MC3302

ORDERING INFORMATION

Device	Package	Shipping
LM239D	SO-14	55 Units/Rail
LM239DR2	SO-14	2500 Units/Tape & Reel
LM239DTBR2	TSSOP-14	2500 Units/Tape & Reel
LM239N	PDIP-14	25 Units/Rail
LM339D	SO-14	55 Units/Rail
LM339DR2	SO-14	2500 Units/Tape & Reel
LM339DTBR2	TSSOP-14	2500 Units/Tape & Reel
LM339N	PDIP-14	25 Units/Rail
LM2901D	SO-14	55 Units/Rail
LM2901DR2	SO-14	2500 Units/Tape & Reel
LM2901DTBR2	TSSOP-14	2500 Units/Tape & Reel
LM2901N	PDIP-14	25 Units/Rail
LM2901VD	SO-14	55 Units/Rail
LM2901VDR2	SO-14	2500 Units/Tape & Reel
LM2901VDTBR2	TSSOP-14	2500 Units/Tape & Reel
LM2901VN	PDIP-14	25 Units/Rail
NCV2901DR2	SO-14	2500 Units/Tape & Reel
MC3302D	SO-14	55 Units/Rail
MC3302DR2	SO-14	2500 Units/Tape & Reel
MC3302DTBR2	TSSOP-14	2500 Units/Tape & Reel
MC3302P	PDIP-14	25 Units/Rail

MARKING DIAGRAMS

PDIP-14 N, P SUFFIX CASE 646

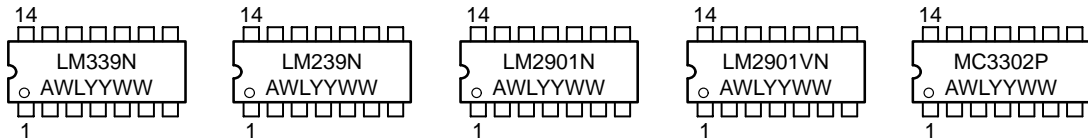

SO-14 D SUFFIX CASE 751A

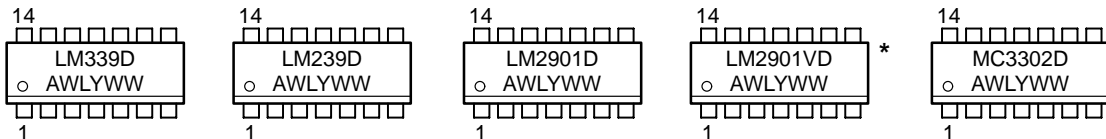

TSSOP-14 DTB SUFFIX CASE 948G

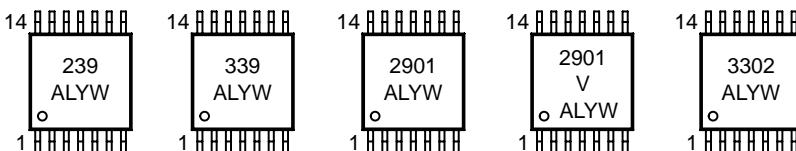

A = Assembly Location
 WL, L = Wafer Lot
 YY, Y = Year
 WW, W = Work Week

*This marking diagram also applies to NCV2901.

LM339, LM239, LM2901, LM2901V, NCV2901, MC3302

PACKAGE DIMENSIONS

PDIP-14
P SUFFIX
CASE 646-06
ISSUE M

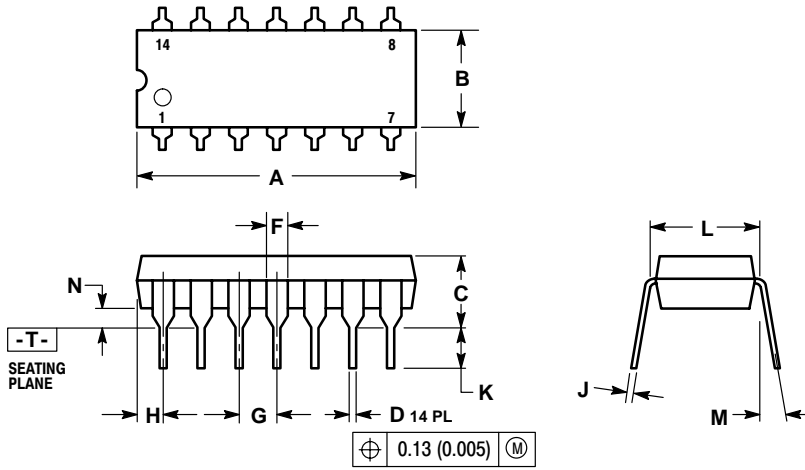

NOTES:

1. DIMENSIONING AND TOLERANCING PER ANSI Y14.5M, 1982.
2. CONTROLLING DIMENSION: INCH.
3. DIMENSION L TO CENTER OF LEADS WHEN FORMED PARALLEL.
4. DIMENSION B DOES NOT INCLUDE MOLD FLASH.
5. ROUNDED CORNERS OPTIONAL.

DIM	INCHES		MILLIMETERS	
	MIN	MAX	MIN	MAX
A	0.715	0.770	18.16	18.80
B	0.240	0.260	6.10	6.60
C	0.145	0.185	3.69	4.69
D	0.015	0.021	0.38	0.53
F	0.040	0.070	1.02	1.78
G	0.100 BSC		2.54 BSC	
H	0.052	0.095	1.32	2.41
J	0.008	0.015	0.20	0.38
K	0.115	0.135	2.92	3.43
L	0.290	0.310	7.37	7.87
M	---	10°	---	10°
N	0.015	0.039	0.38	1.01

SO-14
D SUFFIX
CASE 751A-03
ISSUE F

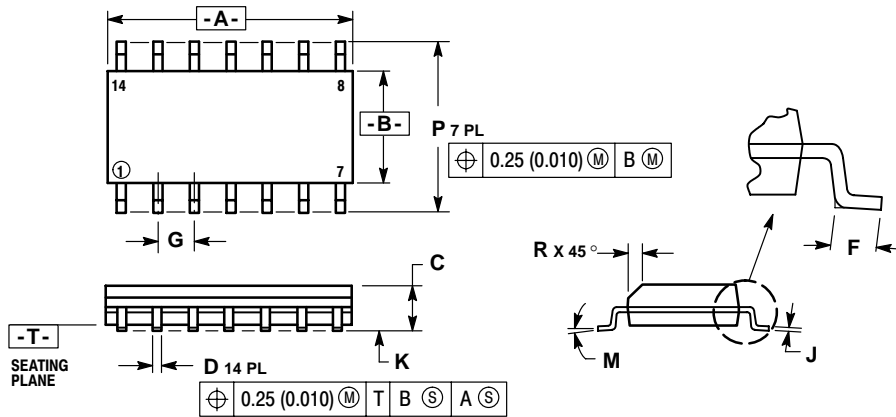

NOTES:

1. DIMENSIONING AND TOLERANCING PER ANSI Y14.5M, 1982.
2. CONTROLLING DIMENSION: MILLIMETER.
3. DIMENSIONS A AND B DO NOT INCLUDE MOLD PROTRUSION.
4. MAXIMUM MOLD PROTRUSION 0.15 (0.006) PER SIDE.
5. DIMENSION D DOES NOT INCLUDE DAMBAR PROTRUSION. ALLOWABLE DAMBAR PROTRUSION SHALL BE 0.127 (0.005) TOTAL IN EXCESS OF THE D DIMENSION AT MAXIMUM MATERIAL CONDITION.

DIM	MILLIMETERS		INCHES	
	MIN	MAX	MIN	MAX
A	8.55	8.75	0.337	0.344
B	3.80	4.00	0.150	0.157
C	1.35	1.75	0.054	0.068
D	0.35	0.49	0.014	0.019
F	0.40	1.25	0.016	0.049
G	1.27 BSC		0.050 BSC	
J	0.19	0.25	0.008	0.009
K	0.10	0.25	0.004	0.009
M	0°	7°	0°	7°
P	5.80	6.20	0.228	0.244
R	0.25	0.50	0.010	0.019

LM339, LM239, LM2901, LM2901V, NCV2901, MC3302

PACKAGE DIMENSIONS

TSSOP-14
DTB SUFFIX
CASE 948G-01
ISSUE O

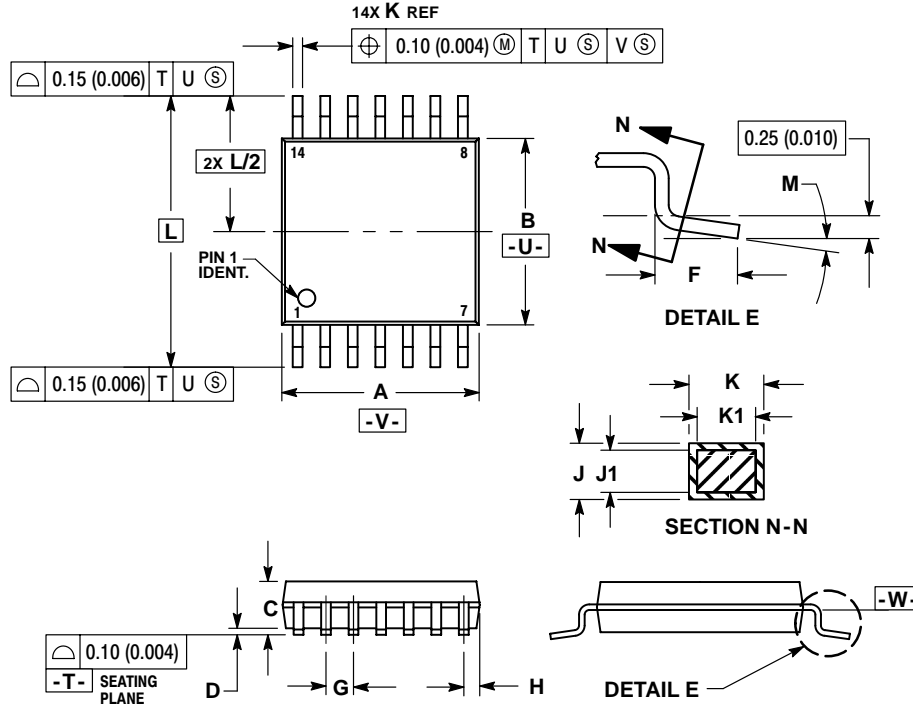

NOTES:

1. DIMENSIONING AND TOLERANCING PER ANSI Y14.5M, 1982.
2. CONTROLLING DIMENSION: MILLIMETER.
3. DIMENSION A DOES NOT INCLUDE MOLD FLASH, PROTRUSIONS OR GATE BURRS. MOLD FLASH OR GATE BURRS SHALL NOT EXCEED 0.15 (0.006) PER SIDE.
4. DIMENSION B DOES NOT INCLUDE INTERLEAD FLASH OR PROTRUSION. INTERLEAD FLASH OR PROTRUSION SHALL NOT EXCEED 0.25 (0.010) PER SIDE.
5. DIMENSION K DOES NOT INCLUDE DAMBAR PROTRUSION. ALLOWABLE DAMBAR PROTRUSION SHALL BE 0.08 (0.003) TOTAL IN EXCESS OF THE K DIMENSION AT MAXIMUM MATERIAL CONDITION.
6. TERMINAL NUMBERS ARE SHOWN FOR REFERENCE ONLY.
7. DIMENSION A AND B ARE TO BE DETERMINED AT DATUM PLANE -W-.

DIM	MILLIMETERS		INCHES	
	MIN	MAX	MIN	MAX
A	4.90	5.10	0.193	0.200
B	4.30	4.50	0.169	0.177
C	---	1.20	---	0.047
D	0.05	0.15	0.002	0.006
F	0.50	0.75	0.020	0.030
G	0.65 BSC		0.026 BSC	
H	0.50	0.60	0.020	0.024
J	0.09	0.20	0.004	0.008
J1	0.09	0.16	0.004	0.006
K	0.19	0.30	0.007	0.012
K1	0.19	0.25	0.007	0.010
L	6.40 BSC		0.252 BSC	
M	0°	8°	0°	8°

ON Semiconductor and are registered trademarks of Semiconductor Components Industries, LLC (SCILLC). SCILLC reserves the right to make changes without further notice to any products herein. SCILLC makes no warranty, representation or guarantee regarding the suitability of its products for any particular purpose, nor does SCILLC assume any liability arising out of the application or use of any product or circuit, and specifically disclaims any and all liability, including without limitation special, consequential or incidental damages. "Typical" parameters which may be provided in SCILLC data sheets and/or specifications can and do vary in different applications and actual performance may vary over time. All operating parameters, including "Typicals" must be validated for each customer application by customer's technical experts. SCILLC does not convey any license under its patent rights nor the rights of others. SCILLC products are not designed, intended, or authorized for use as components in systems intended for surgical implant into the body, or other applications intended to support or sustain life, or for any other application in which the failure of the SCILLC product could create a situation where personal injury or death may occur. Should Buyer purchase or use SCILLC products for any such unintended or unauthorized application, Buyer shall indemnify and hold SCILLC and its officers, employees, subsidiaries, affiliates, and distributors harmless against all claims, costs, damages, and expenses, and reasonable attorney fees arising out of, directly or indirectly, any claim of personal injury or death associated with such unintended or unauthorized use, even if such claim alleges that SCILLC was negligent regarding the design or manufacture of the part. SCILLC is an Equal Opportunity/Affirmative Action Employer.

PUBLICATION ORDERING INFORMATION

Literature Fulfillment:

Literature Distribution Center for ON Semiconductor
P.O. Box 5163, Denver, Colorado 80217 USA
Phone: 303-675-2175 or 800-344-3860 Toll Free USA/Canada
Fax: 303-675-2176 or 800-344-3867 Toll Free USA/Canada
Email: ONlit@hibbertco.com

N. American Technical Support: 800-282-9855 Toll Free USA/Canada

JAPAN: ON Semiconductor, Japan Customer Focus Center
2-9-1 Kamimeguro, Meguro-ku, Tokyo, Japan 153-0051
Phone: 81-3-5773-3850

ON Semiconductor Website: <http://onsemi.com>

For additional information, please contact your local Sales Representative.