



## Digital Alarm Clock

### Overview

The LM8562 is a digital clock-use LSI having features such as easy setting, two alarms. Since the LM8562 is designed to be able to direct drive an LED panel of duplex type, the package in which the LM8562 is placed is a 28-pin shrink DIP with a small mounting area.

### Features

- (1) Duplex LED display (LM8560-use LED panel usable)
- (2) Two alarms on chip (600 Hz, 1200 Hz)
- (3) Up, down/fast, slow time setting available (easy setting)
- (4) 12/24-hour mode, 50/60 Hz selectable (provided that it is impossible to select the combination of 24-hour mode and 60 Hz)
- (5) On-chip CR oscillator for backup use at the time of power failure
- (6) Power failure indicator
- (7) 59-minute alarm/sleep timer
- (8) 6-minute snooze function
- (9) Radio output function
- (10) P-channel ED MOS
- (11) Pin 28 dual-in-line shrink package
- (12) Wide operating voltage/operating temperature range  
 $V_{DD} = -14$  to  $-8$  V /  $-20$  to  $+70^{\circ}\text{C}$

### Package Dimensions

unit : mm

#### 3029A-DIP28S

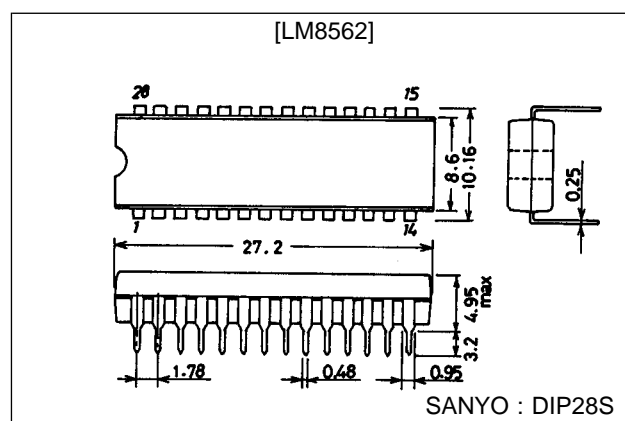

### Specifications

#### Absolute Maximum Ratings at $T_a = 25^{\circ}\text{C}$ , $V_{SS} = 0$ V

| Parameter                   | Symbol       | Conditions                 | Ratings       | Unit               |
|-----------------------------|--------------|----------------------------|---------------|--------------------|
| Supply voltage              | $V_{DD}$ max |                            | -17.0 to +0.3 | V                  |
| Input voltage               | $V_{IN}$     |                            | -17.0 to +0.3 | V                  |
| Output voltage              | $V_{OUT}$    |                            | -17.0 to +0.3 | V                  |
| Allowable power dissipation | $P_d$ max    | $T_a = 70^{\circ}\text{C}$ | 0.7           | W                  |
| Operating temperature       | $T_{opr}$    |                            | -20 to +70    | $^{\circ}\text{C}$ |
| Storage temperature         | $T_{stg}$    |                            | -55 to +125   | $^{\circ}\text{C}$ |

## LM8562

### Allowable Operating Conditions at $T_a = -20$ to $+70^\circ\text{C}$ , $V_{SS} = 0$ V

| Parameter                | Symbol    | Conditions                      | min              | typ | max              | Unit |
|--------------------------|-----------|---------------------------------|------------------|-----|------------------|------|
| Supply voltage           | $V_{DD}$  |                                 | -14              |     | -8               | V    |
| Standby voltage          | $V_{ST}$  |                                 |                  |     | -7.5             | V    |
| Input high-level voltage | $V_{IH1}$ | 50/60 Hz INPUT pin              | $V_{SS}-1$       |     | $V_{SS}$         | V    |
| Input low-level voltage  | $V_{IL1}$ |                                 |                  |     | $V_{DD}+2$       | V    |
| Input high-level voltage | $V_{IH2}$ | CR OSC pin                      | $V_{SS}-1$       |     | $V_{SS}$         | V    |
| Input low-level voltage  | $V_{IL2}$ |                                 |                  |     | $V_{DD} + 2$     | V    |
| Input high-level voltage | $V_{IH3}$ | 3-level input pins              | $V_{SS} - 0.7$   |     | $V_{SS}$         | V    |
| Input mid-level voltage  | $V_{IM}$  |                                 | $1/2 V_{DD} - 1$ |     | $1/2 V_{DD} + 1$ | V    |
| Input low-level voltage  | $V_{IL3}$ |                                 | $V_{DD}$         |     | $V_{DD} + 1$     | V    |
| Input high-level voltage | $V_{IH4}$ | Input pins other than the above | $V_{SS} - 2$     |     | $V_{SS}$         | V    |
| Input low-level voltage  | $V_{IL4}$ |                                 |                  |     | $V_{DD} + 2$     | V    |
| Input level hold time    | tH        |                                 | 10               |     |                  | ms   |
| Input chattering time    | tC        |                                 | 10               |     |                  | ms   |

### Electrical Characteristics at $T_a = 25 \pm 2^\circ\text{C}$ , $V_{SS} = 0$ V, $V_{DD} = -12$ V

| Parameter                        | Symbol    | Conditions  | min  | typ  | max     | Unit             |
|----------------------------------|-----------|---|------|------|---------|------------------|
| Output high-level current        | $I_{OH1}$ | AM & 10'SHR ag & de pin,<br>$V_{OUT} = V_{SS} - 2.0$ V                  | 32   |      | (Note1) | mA               |
| Output OFF-state leakage current | $I_{OF1}$ | $V_{OUT} = V_{DD}$  |      |      | 20      | $\mu\text{A}$    |
| Output high-level current        | $I_{OH2}$ | Segment output pins other than the<br>above, $V_{OUT} = V_{SS} - 2.0$ V | 16   |      | (Note1) | mA               |
| Output OFF-state leakage current | $I_{OF2}$ | $V_{OUT} = V_{DD}$  |      |      | 20      | $\mu\text{A}$    |
| Output high-level current        | $I_{OH3}$ | ALM-1, ALM-2, RADIO OUTPUT pin,<br>$V_{OUT} = V_{SS} - 2.0$ V           | 2    |      |         | mA               |
| Output OFF-state leakage current | $I_{OF3}$ | $V_{OUT} = V_{DD}$  |      |      | 10      | $\mu\text{A}$    |
| Operating frequency              | fop       | 50/60 Hz INPUT pin  | DC   |      | 2000    | Hz               |
| Input high-level current         | $I_{IH1}$ | $V_{IH} = V_{SS}$   |      |      | 10      | $\mu\text{A}$    |
| Input low-level current          | $I_{IL1}$ | $V_{IL} = V_{DD}$   | -10  |      |         | $\mu\text{A}$    |
| Input high-level current         | $I_{IH2}$ | CR OSC pin, $V_{IH} = V_{SS}$   |      |      | 10      | $\mu\text{A}$    |
| Input low-level current          | $I_{IL2}$ | $V_{IL} = V_{DD}$   |      | 60   |         | $\mu\text{A}$    |
| Input high-level current         | $I_{IH3}$ | 3-level input pins, $V_{IH} = V_{SS}$                                   | 20   |      | 120     | $\mu\text{A}$    |
| Input low-level current          | $I_{IL3}$ | $V_{IL} = V_{DD}$   | -120 |      | -20     | $\mu\text{A}$    |
| Pull-down resistance             | $R_{PD}$  | 3-level input pins, $V_{IN} = 1/2 V_{DD}$                               |      | 1.0  |         | $\text{M}\Omega$ |
| Pull-up resistance               | $R_{PU}$  | $V_{IN} = 1/2 V_{DD}$   |      | 0.8  |         | $\text{M}\Omega$ |
| Operating current                | $I_{DD}$  | Output : No load  | 2    | 8    | 15      | mA               |
| Power failure detect circuit     | $V_{BU}$  |   | -7.5 | -5.0 |         | V                |
| OSC stability                    | $f_S$     | $V_{DD} = -9$ V $\pm$ 10%   | -10  |      | 10      | %                |
| OSC accuracy                     | $f_A$     | $V_{DD} = -9$ V   | -10  |      | 10      | %                |
| OSC frequency                    | $f_{OSC}$ | $R = 180$ k $\Omega$ , $C = 3300$ pF                                    |      | 2400 |         | Hz               |

Note 1 : The allowable segment current drain is 78 mA max. for AM & 10'SHR ag & de and 39 mA max. for other than AM & 10'SHR ag & de in the range of power dissipation 700 mW.

# LM8562

## Pin Assignment

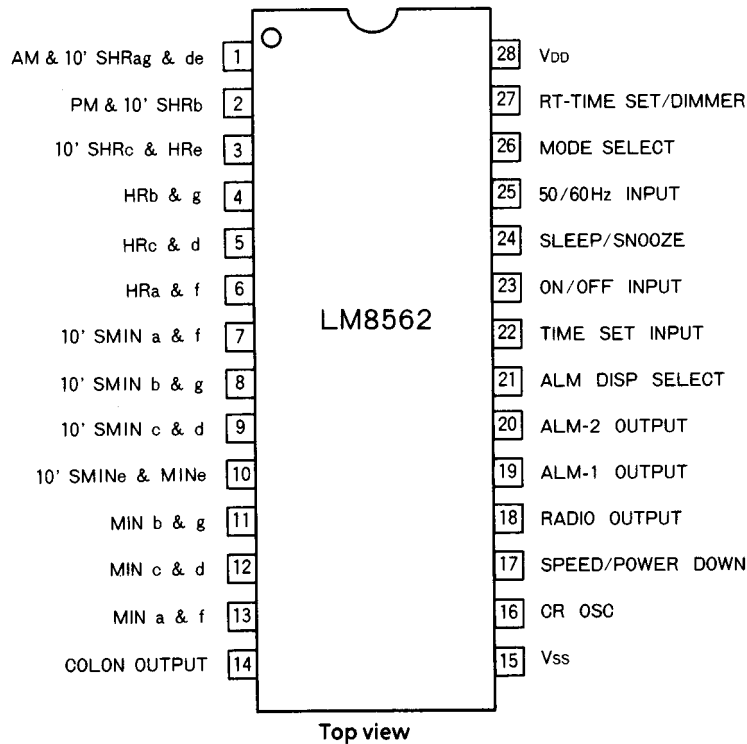

## Pin Functions

### 1. 3-Level Input Pins

| No. | Pin Name           | Input Level                            |   |                                       |
|-----|--------------------|--|---|---------------------------------------|
|     |                    | V <sub>SS</sub>                        | OPEN                                    | V <sub>DD</sub>                       |
| 17  | SPEED/POWER DOWN   | Test mode                              | Normal                                  | Power-down mode                       |
| 21  | ALM-DISP SELECT    | Alarm 2 display & setting              | NOP                                     | Alarm 1 display & setting             |
| 22  | TIME SET INPUT     | Slow-down (AC = fast-down)             | NOP                                     | Slow-up (AC = fast-up)                |
| 23  | ON/OFF INPUT       | ON                                     | NOP                                     | OFF                                   |
| 24  | SLEEP/SNOOZE       | Sleep display & sleep-in               | NOP                                     | Second display & snooze-in            |
| 26  | MODE SELECT        | 24-hour mode, 50 Hz                    | 12-hour mode, 50 Hz                     | 12-hour mode, 60 Hz                   |
| 27  | RT-TIME SET/DIMMER | Time setting inhibit<br>Dimmer display | Timer setting inhibit<br>Normal display | Time setting enable<br>Normal display |

NOP : No operation

AC : Pulse input

### 2. Input/Output Pins

| No. | Pin Name     | Input Level       |                 |
|-----|--------------|-------------------|-----------------|
|     |              | V <sub>SS</sub>   | V <sub>DD</sub> |
| 18  | RADIO OUTPUT | —                 | When not used   |
| 19  | ALM-1 OUTPUT | —                 | Alarm1 OFF      |
| 20  | ALM-2 OUTPUT | —                 | Alarm2 OFF      |
| 16  | CR OSC       | 1-pin OSC circuit |                 |

### 3. Input Pins

No.25 50/60 Hz INPUT = 50 Hz or 60 Hz clock signal input

No.15, 28 V<sub>SS</sub>, V<sub>DD</sub> = Power supply pin

# LM8562

## 4. Output Pins

| No. | Pin Name            | Drive Phase  |           |
|-----|---------------------|--------------|-----------|
|     |                     | 1            | 2         |
| 1   | AM & 10'SHR ag & de | AM 10'SHR ad | 10'SHR eg |
| 2   | PM & 10'SHR b       | PM           | 10'SHR b  |
| 3   | 10'SHR c & HR e     | HR e         | 10'SHR c  |
| 4   | HR b & g            | HR g         | HR b      |
| 5   | HR c & d            | HR d         | HR c      |
| 6   | HR a & f            | HR f         | HR a      |
| 7   | 10'SMIN a & f       | 10'SMIN a    | 10'SMIN f |
| 8   | 10'SMIN b & g       | 10'SMIN b    | 10'SMIN g |
| 9   | 10'SMIN c & d       | 10'SMIN c    | 10'SMIN d |
| 10  | 10'SMIN e & MIN e   | MIN e        | 10'SMIN e |
| 11  | MIN b & g           | MIN g        | MIN b     |
| 12  | MIN c & d           | MIN d        | MIN c     |
| 13  | MIN a & f           | MIN f        | MIN a     |
| 14  | COLON OUTPUT        | COLON        | —         |

## Display Mode

| Select Pin                                |                    | Display Mode   | Digit No.          |         |                 |         |
|---|--------------------|----------------|--------------------|---------|-----------------|---------|
| ALM-DISP SELECT                           | SLEEP/SNOOZE INPUT |                | 1                  | 2       | 3               | 4       |
| OPEN                                      | OPEN               | Time display   | AM/PM<br>10's hour | Hour    | 10's<br>minutes | Minutes |
| V <sub>DD</sub>                           | OPEN               | Alarm 1        | AM/PM<br>10's hour | Hour    | 10's<br>minutes | Minutes |
| V <sub>SS</sub>                           | OPEN               | Alarm 2        | AM/PM<br>10's hour | Hour    | 10's<br>minutes | Minutes |
| OPEN (V <sub>DD</sub> , V <sub>SS</sub> ) | V <sub>SS</sub>    | Sleep          | Unlit              | 0       | 10's<br>minutes | Minutes |
| OPEN (V <sub>DD</sub> , V <sub>SS</sub> ) | V <sub>DD</sub>    | second display | Unlit              | Minutes | 10's<br>seconds | Seconds |

## Operation Description

- Segment Output  
The duplex LED panel can be direct driven by 13 segment output pins.  
(Compatible with LM8560-use LED panel)
- Colon Output  
LED panel

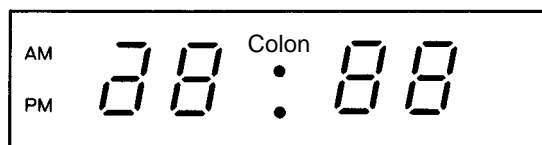

The drive phase is phase 1. The colon always flashes at 1 Hz rate.

- OSC Circuit  
By connecting a resistor and a capacitor with the CR INPUT pin, a 2.4 kHz OSC circuit is formed. The clock signal generated by the 2.4 kHz OSC circuit is used in the following cases.
  - Used as the clock signal for the time counter, instead of 50/60 Hz INPUT, when the power-down mode is entered.
  - Alarm sound (1200 Hz or 600 Hz) at the alarm signal output mode
  - 1/25 duty clock signal while the dimmer is in operation
- Power-Down Mode
  - Since the backup OSC circuit holds the current time, the LM8562 starts operating immediately.
  - The snooze function stops operating.
  - The RADIO OUTPUT pin is brought to the OFF state.
  - The control input is inhibited (except the following).
    - OFF INPUT
    - ALARM/SLEEP TIME SET INPUT at the time setting enable mode

## LM8562

### 5. Alarm

The LM8562 contains two alarms on a 24-hour basis.

Alarm 1 ..... Superposition of 600 Hz and 1 Hz

Alarm 2 ..... Superposition of 1200 Hz and 1 Hz

6-minutes snooze

The alarm output duration time is 59 minutes. The 59-minute duration counter is common to the alarm 1, alarm2, and sleep timer.

### 6. Time Setting, Dimmer

The 3 level input RT-TIME SET/DIMMER INPUT pin provides the following functions.

| RT-TIME SET/DIMMER INPUT Pin Input | Functions   |
|------------------------------------|---|
| $V_{DD}$                           | Time setting enable, normal display<br>• Time, alarm time, sleep timer duration time setting enable         |
| OPEN                               | Time setting inhibit, normal display<br>• Time setting enable (except power-down mode)                      |
| $V_{SS}$                           | Time setting inhibit, dimmer display<br>• Display brightness 50 Hz mode: 1/24 duty<br>60 Hz mode: 1/20 duty |

The 3-level input TIME-SET INPUT pin provides the following operations.

| TIME-SET INPUT Pin Input |                       | Operations   |
|--------------------------|-----------------------|--------------|
| $V_{DD}$                 | AC (50/60 Hz or more) | Fast-up      |
|                          | DC (20 ms min.)       | Slow-up      |
| OPEN                     |                       | No operation |
| $V_{SS}$                 | AC (50/60 Hz or more) | Fast-down    |
|                          | DC (20 ms min.)       | Slow-down    |

Setting Contents

① Fast-up/down 50/60 Hz rate

② Slow-up/down Immediately incremented/decremented  $\pm 1$  and counted up/down at a 2 Hz rate 0.5 to 1.0 second later

### 7. ON/OFF INPUT Pin

The 3-level input ON/OFF INPUT pin acts on the ALM-1, 2 RADIO OUTPUT pins as shown below.

| Output Pin   | ON-State Condition   | Pause Conditions | OFF-State Conditions  |
|--------------|--|------------------|---|
| ALM-1 OUTPUT | Alarm 1 setting time = Current time                        | Snooze-in        | <ul style="list-style-type: none"> <li>• ON/OFF INPUT = <math>V_{SS}</math></li> <li>• ON/OFF INPUT = <math>V_{DD}</math></li> <li>• Sleep-in</li> <li>• 59 minutes after the alarm 1 is turned ON</li> <li>• ALM-1 OUTPUT = <math>V_{DD}</math></li> </ul> |
| ALM-2 OUTPUT | Alarm 2 setting time = Current time                        | Snooze-in        | <ul style="list-style-type: none"> <li>• ON/OFF INPUT = <math>V_{SS}</math></li> <li>• ON/OFF INPUT = <math>V_{DD}</math></li> <li>• Sleep-in</li> <li>• 59 minutes after the alarm 2 is turned ON</li> <li>• ALM-2 OUTPUT = <math>V_{DD}</math></li> </ul> |
| RADIO OUTPUT | ON/OFF INPUT = $V_{SS}$<br>(ON-state indicator : ON state) | —                | <ul style="list-style-type: none"> <li>• ON/OFF INPUT = <math>V_{DD}</math></li> <li>• Power-down mode</li> <li>• Sleep-in<br/>(On-state indicator : OFF state)</li> </ul>  |
|              | Sleep-in<br>(Sleep indicator : ON state)                   | —                | <ul style="list-style-type: none"> <li>• ON/OFF INPUT = <math>V_{SS}</math></li> <li>• ON/OFF INPUT = <math>V_{DD}</math></li> <li>• Power-down mode<br/>(Sleep indicator : OFF state)</li> </ul>   |

### 8. Sleep, Snooze Timer

The 3-level input SLEEP/SNOOZE INPUT pin operates as shown below.

| SLEEP/SNOOZE INPUT Pin Input | Operation  |
|------------------------------|--|
| $V_{DD}$ (20 ms min.)        | Snooze-in & seconds display mode<br>• The alarm stops functioning for 6 to 7 minutes.<br>• Seconds display   |
| OPEN                         | No operation   |
| $V_{SS}$ (20 ms min.)        | Sleep mode<br>• The sleep counter is set to operate for 59 minutes.<br>• Counted down automatically at a 2 Hz rate 1.5 to 2.0 seconds later<br>• Fast/slow, up/down time setting available |

# LM8562

9. 50/60 Hz INPUT Pin  
The LM8562 contains a Schmitt circuit so that a simple CR filter can be used to remove the noise of commercial frequency 50/60 Hz.
10. 12/24-Hour Mode, 50/60 Hz Select  
The 3-level input MODE SELECT pin provides the following combinations.

| MODE SELECT Pin Input | Select               |
|-----------------------|----------------------|
| $V_{DD}$              | 12-hour mode & 60 Hz |
| OPEN                  | 12-hour mode & 50 Hz |
| $V_{SS}$              | 24-hour mode & 50 Hz |

## Sample Application Circuit

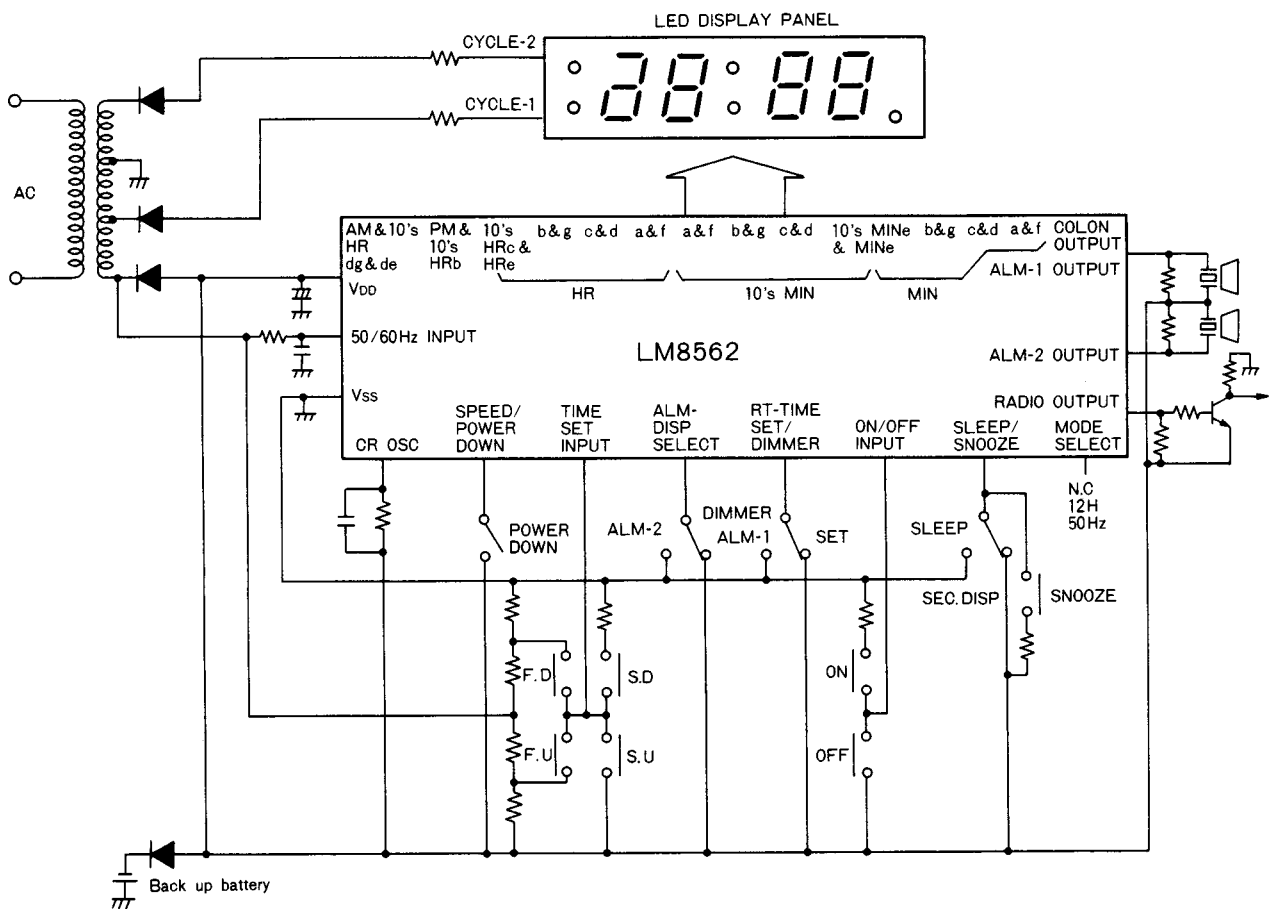

Block Diagram

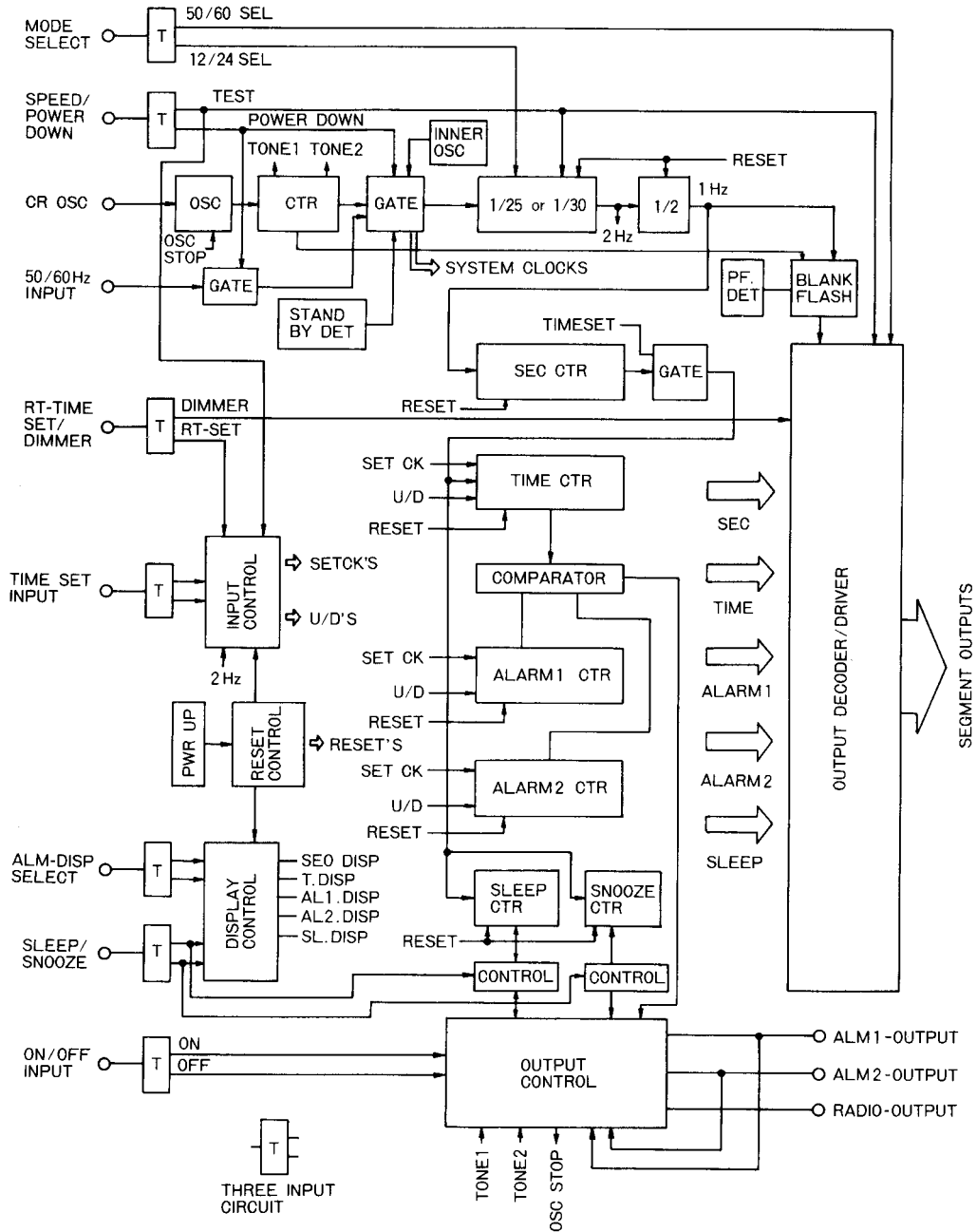

■ No products described or contained herein are intended for use in surgical implants, life-support systems, aerospace equipment, nuclear power control systems, vehicles, disaster/crime-prevention equipment and the like, the failure of which may directly or indirectly cause injury, death or property loss.

■ Anyone purchasing any products described or contained herein for an above-mentioned use shall:

- ① Accept full responsibility and indemnify and defend SANYO ELECTRIC CO., LTD., its affiliates, subsidiaries and distributors and all their officers and employees, jointly and severally, against any and all claims and litigation and all damages, cost and expenses associated with such use:
- ② Not impose any responsibility for any fault or negligence which may be cited in any such claim or litigation on SANYO ELECTRIC CO., LTD., its affiliates, subsidiaries and distributors or any of their officers and employees jointly or severally.

■ Information (including circuit diagrams and circuit parameters) herein is for example only; it is not guaranteed for volume production. SANYO believes information herein is accurate and reliable, but no guarantees are made or implied regarding its use or any infringements of intellectual property rights or other rights of third parties.

This catalog provides information as of December, 1997. Specifications and information herein are subject to change without notice.