

1.1 GHz PLL Frequency Synthesizer

The MC145193 is recommended for new designs and offers reduced power consumption. The counters are programmed via a synchronous serial port which is SPI compatible. The serial port is byte-oriented to facilitate control via an MCU. Due to the innovative BitGrabber Plus™ registers, the MC145193 may be cascaded with other peripherals featuring BitGrabber Plus without requiring leading dummy bits or address bits in the serial data stream. In addition, BitGrabber Plus peripherals may be cascaded with existing BitGrabber™ peripherals.

The device features a single-ended current source/sink phase detector A output and a double-ended phase detector B output. Both phase detectors have linear transfer functions (no dead zones). The maximum current of the single-ended phase detector output is determined by an external resistor tied from the Rx pin to ground. This current can be varied via the serial port.

Slew-rate control is provided by a special driver designed for the REF_{out} pin. This minimizes interference caused by REF_{out}.

This part includes a differential RF input that may be operated in a single-ended mode. Also featured are on-board support of an external crystal and a programmable reference output. The R, A, and N counters are fully programmable. The C register (configuration register) allows the part to be configured to meet various applications. A patented feature allows the C register to shut off unused outputs, thereby minimizing system noise and interference.

In order to have consistent lock times and prevent erroneous data from being loaded into the counters, on-board circuitry synchronizes the update of the A register if the A or N counters are loading. Similarly, an update of the R register is synchronized if the R counter is loading.

The double-buffered R register allows new divide ratios to be presented to the three counters (R, A, and N) simultaneously.

- Maximum Operating Frequency: 1100 MHz @ - 10 dBm
- Operating Supply Current: 3 mA Nominal at 3.0 V
- Operating Supply Voltage Range (V_{DD}, V_{CC}, V_{PD} Pins): 2.7 to 5.5 V
- Current Source/Sink Phase Detector Output:
1.7 mA @ 5.0 V or 1.0 mA @ 3.0 V
- Gain of Current Source/Sink Phase/Frequency Detector Controllable via Serial Port
- R Counter Division Range: 1 and 5 to 8191
- Dual-Modulus Capability Provides Total Division up to 262,143
- High-Speed Serial Interface: 4 Mbps
- Output A Pin, When Configured as Data Out, Permits Cascading of Devices
- Two General-Purpose Digital Outputs:
Output A: Totem-Pole (Push-Pull) with Four Output Modes
Output B: Open-Drain
- Patented Power-Saving Standby Feature with Orderly Recovery for Minimizing Lock Times, Standby Current: 30 μA
- See App Note AN1253/D for Low-Pass Filter Design, and AN1277/D for Offset Reference PLLs for Fine Resolution or Fast Hopping

BitGrabber and BitGrabber Plus are trademarks of Motorola, Inc.

MC145193

PLL FREQUENCY SYNTHESIZER

SEMICONDUCTOR TECHNICAL DATA

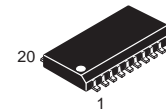

F SUFFIX
PLASTIC PACKAGE
CASE 751J
(SO-20)

PIN CONNECTIONS

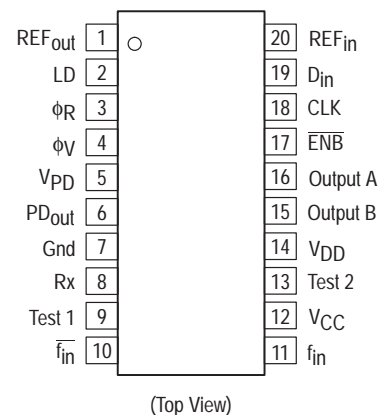

EVALUATION KIT

The MC145193EVK, which contains hardware and software, is available.

ORDERING INFORMATION

Device	Operating Temperature Range	Package
MC145193F	T _A = -40 to 85°C	SO-20

MC145193

BLOCK DIAGRAM

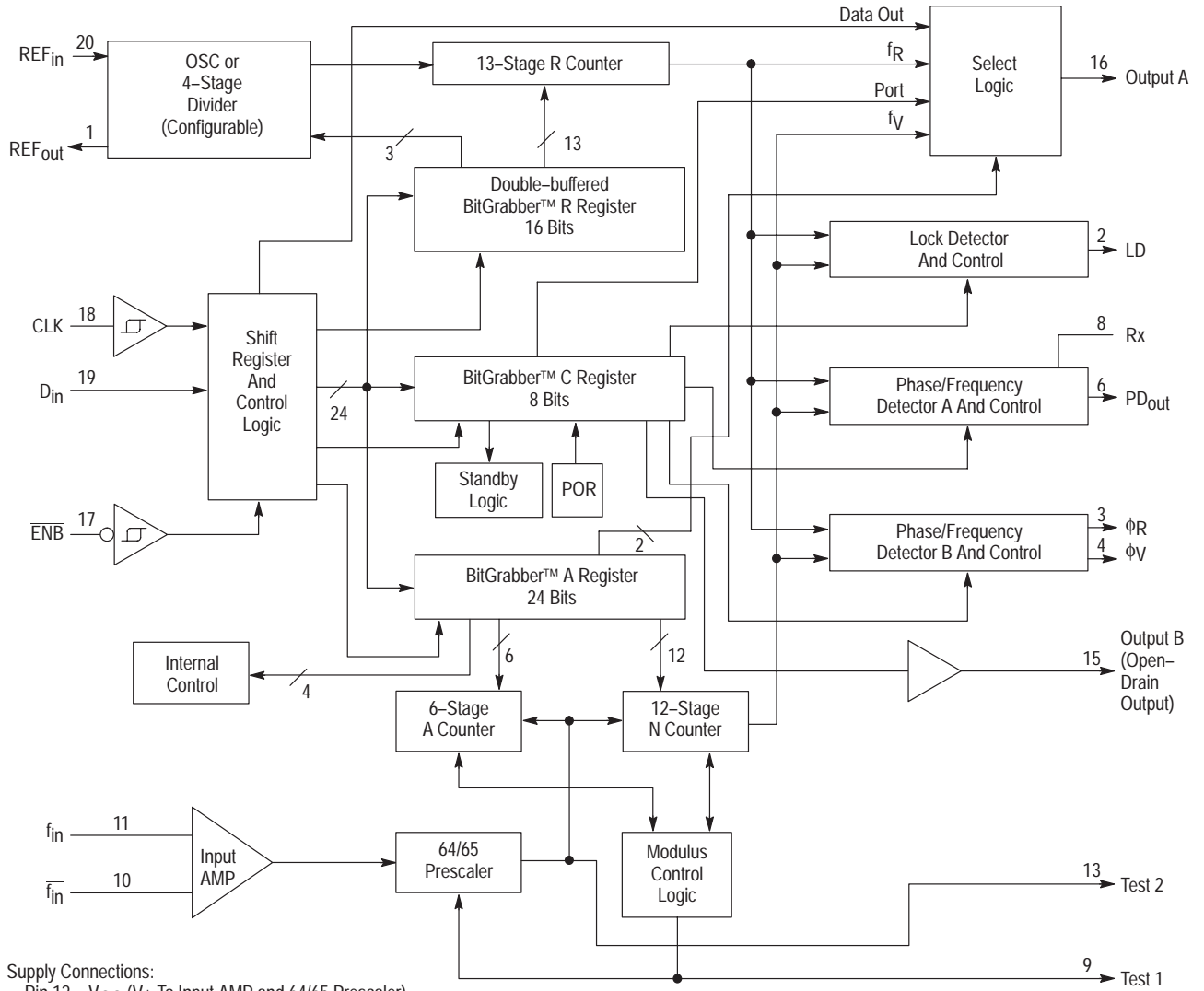

Supply Connections:
 Pin 12 = V_{CC} ($V+$ To Input AMP and 64/65 Prescaler)
 Pin 5 = V_{PD} ($V+$ To Phase/Frequency Detectors A and B)
 Pin 14 = V_{DD} ($V+$ To Balance Of Circuit)
 Pin 7 = Gnd (Common Ground)

This device contains 7,278 active transistors.

MC145193

MAXIMUM RATINGS* (Voltages Referenced to Gnd, unless otherwise stated)

Parameter	Symbol	Value	Unit
DC Supply Voltage (Pins 12 and 14)	V_{CC}, V_{DD}	-0.5 to 6.0	V
DC Supply Voltage (Pin 5)	V_{PD}	$V_{DD} - 0.5$ to 6.0	V
DC Input Voltage	V_{in}	-0.5 to $V_{DD} + 0.5$	V
DC Output Voltage (except Output B, PD_{out} , ϕ_R , ϕ_V)	V_{out}	-0.5 to $V_{DD} + 0.5$	V
DC Output Voltage (Output B, PD_{out} , ϕ_R , ϕ_V)	V_{out}	-0.5 to $V_{PD} + 0.5$	V
DC Input Current, per Pin (Includes V_{PD})	I_{in}, I_{PD}	± 10	mA
DC Output Current, per Pin	I_{out}	± 20	mA
DC Supply Current, V_{DD} and Gnd Pins	I_{DD}	± 30	mA
Power Dissipation, per Package	P_D	300	mW
Storage Temperature	T_{stg}	-65 to 150	°C
Lead Temperature, 1 mm from Case for 10 Seconds	T_L	260	°C

This device contains protection circuitry to guard against damage due to high static voltages or electric fields. However, precautions must be taken to avoid applications of any voltage higher than maximum rated voltages to this high-impedance circuit.

- NOTES:**
1. Maximum Ratings are those values beyond which damage to the device may occur. Functional operation should be restricted to the limits in the Electrical Characteristics tables or Pin Descriptions section.
 2. ESD (electrostatic discharge) immunity meets Human Body Model (HBM) ≤ 2000 V and Machine Model (MM) ≤ 200 V. Additional ESD data available upon request.

ELECTRICAL CHARACTERISTICS

($V_{DD} = V_{CC} = 2.7$ to 5.5 V, Voltages Referenced to Gnd, unless otherwise stated; $V_{PD} = 2.7$ to 5.5 V, $T_A = -40$ to 85°C)

Parameter	Test Condition	Symbol	Guaranteed Limit	Unit
Maximum Low-Level Input Voltage (D_{in} , CLK, \overline{ENB})		V_{IL}	$0.3 \times V_{DD}$	V
Minimum High-Level Input Voltage (D_{in} , CLK, \overline{ENB})		V_{IH}	$0.7 \times V_{DD}$	V
Minimum Hysteresis Voltage (CLK, \overline{ENB})	$V_{DD} = 2.7$ V $V_{DD} = 4.5$ V	V_{Hys}	100 250	mV
Maximum Low-Level Output Voltage (REF_{out} , Output A)	$I_{out} = 20 \mu\text{A}$, Device in Reference Mode	V_{OL}	0.1	V
Minimum High-Level Output Voltage (REF_{out} , Output A)	$I_{out} = -20 \mu\text{A}$, Device in Reference Mode	V_{OH}	$V_{DD} - 0.1$	V
Minimum Low-Level Output Current (REF_{out} , LD)	$V_{out} = 0.3$ V	I_{OL}	0.36	mA
Minimum Low-Level Output Current (ϕ_R , ϕ_V)	$V_{out} = 0.3$ V	I_{OL}	0.36	mA
Minimum Low-Level Output Current (Output A)	$V_{out} = 0.4$ V $V_{DD} = 4.5$ V	I_{OL}	1.0	mA
Minimum Low-Level Output Current (Output B)	$V_{out} = 0.4$ V	I_{OL}	1.0	mA
Minimum High-Level Output Current (REF_{out} , LD)	$V_{out} = V_{DD} - 0.3$ V	I_{OH}	-0.36	mA
Minimum High-Level Output Current (ϕ_R , ϕ_V)	$V_{out} = V_{PD} - 0.3$ V	I_{OH}	-0.36	mA
Minimum High-Level Output Current (Output A Only)	$V_{out} = V_{DD} - 0.4$ V $V_{DD} = 4.5$ V	I_{OH}	-0.6	mA

(continued)

MC145193

ELECTRICAL CHARACTERISTICS (continued)

Parameter	Test Condition	Symbol	Guaranteed Limit	Unit
Maximum Input Leakage Current (D _{in} , CLK, $\overline{\text{ENB}}$, REF _{in})	V _{in} = V _{DD} or Gnd, Device in XTAL Mode	I _{in}	±1.0	μA
Maximum Input Current (REF _{in})	V _{in} = V _{DD} or Gnd, Device in Reference Mode	I _{in}	±100	μA
Maximum Output Leakage Current (PD _{out}) (Output B)	V _{out} = V _{PD} or Gnd, Output in Floating State	I _{OZ}	±130	nA
	V _{out} = V _{PD} or Gnd, Output in High-Impedance State		±1	μA
Maximum Standby Supply Current (V _{DD} + V _{PD} Pins)	V _{in} = V _{DD} or Gnd; Outputs Open; Device in Standby Mode, Shut-Down Crystal Mode or REF _{out} -Static-Low Reference Mode; Output B Controlling V _{CC} per Figure 21	I _{STBY}	30	μA
Maximum Phase Detector Quiescent Current (V _{PD} Pin)	Bit C6 = High Which Selects Phase Detector A, PD _{out} = Open, PD _{out} = Static State, Bit C4 = Low Which is not Standby, I _{Rx} = 170 μA, V _{PD} = 5.5 V	I _{PD}	750	μA
	Bit C6 = Low Which Selects Phase Detector B, φ _R and φ _V = Open, φ _R and φ _V = Static Low or High, Bit C4 = Low Which is not Standby		30	
Total Operating Supply Current (V _{DD} + V _{PD} + V _{CC} Pins)	f _{in} = 2.0 GHz; REF _{in} = 13 MHz @ 1 V _{pp} ; Output A = Inactive and No Connect; V _{DD} = V _{CC} , REF _{out} , φ _V , φ _R , PD _{out} , LD = No Connect; D _{in} , $\overline{\text{ENB}}$, CLK = V _{DD} or Gnd, Phase Detector B Selected (Bit C6 = Low)	I _T	[Note]	mA

NOTE: The nominal value is: 3 mA at V_{DD} = V_{CC} = V_{PD} = 3.0 V. This is not a guaranteed limit.

ANALOG CHARACTERISTICS — CURRENT SOURCE/SINK OUTPUT — PD_{out}

(I_{out} ≤ 1 mA @ V_{DD} = 2.7 V and I_{out} ≤ 1.7mA @ V_{DD} ≥ 4.5 V, V_{DD} = V_{CC} = 2.7 to 5.5 V, Voltages Referenced to Gnd)

Parameter	Test Condition	V _{PD}	Guaranteed Limit	Unit
Maximum Source Current Variation (Part-to-Part)	V _{out} = 0.5 x V _{PD}	2.7	±15	%
		4.5	±15	
		5.5	±15	
Maximum Sink-vs-Source Mismatch [Note 3]	V _{out} = 0.5 x V _{PD}	2.7	11	%
		4.5	11	
		5.5	11	
Output Voltage Range [Note 3]	I _{out} Variation ≤ 15%	2.7	0.5 to 2.2	V
	I _{out} Variation ≤ 20%	4.5	0.5 to 3.7	
	I _{out} Variation ≤ 22%	5.5	0.5 to 4.7	

NOTES: 1. Percentages calculated using the following formula: (Maximum Value – Minimum Value)/Maximum Value.

2. See Rx Pin Description for external resistor values.

3. This parameter is guaranteed for a given temperature within –40 to 85°C.

MC145193

AC INTERFACE CHARACTERISTICS

($V_{DD} = V_{CC} = 2.7$ to 5.5 V, $T_A = -40$ to $+85^\circ\text{C}$, $C_L = 25$ pF, Input $t_r = t_f = 10$ ns; $V_{PD} = 2.7$ to 5.5 V)

Parameter	Figure No.	Symbol	Guaranteed Limit	Unit
Serial Data Clock Frequency (Note: Refer to Clock t_w below)	1	f_{clk}	dc to 4.0	MHz
Maximum Propagation Delay, CLK to Output A (Selected as Data Out)	1, 5	t_{PLH} , t_{PHL}	100	ns
Maximum Propagation Delay, $\overline{\text{ENB}}$ to Output A (Selected as Port)	2, 5	t_{PLH} , t_{PHL}	150	ns
Maximum Propagation Delay, $\overline{\text{ENB}}$ to Output B	2, 6	t_{PZL} , t_{PLZ}	150	ns
Maximum Output Transition Time, Output A and Output B; t_{THL} only, on Output B	1, 5, 6	t_{TLH} , t_{THL}	50	ns
Maximum Input Capacitance – D_{in} , $\overline{\text{ENB}}$, CLK		C_{in}	10	pF

TIMING REQUIREMENTS

($V_{DD} = V_{CC} = 2.7$ to 5.5 V, $T_A = -40$ to $+85^\circ\text{C}$, Input $t_r = t_f = 10$ ns, unless otherwise indicated)

Parameter	Figure No.	Symbol	Guaranteed Limit	Unit
Minimum Setup and Hold Times, D_{in} vs CLK	3	t_{su} , t_{h}	50	ns
Minimum Setup, Hold and Recovery Times, $\overline{\text{ENB}}$ vs CLK	4	t_{su} , t_{h} , t_{rec}	100	ns
Minimum Pulse Width, $\overline{\text{ENB}}$	4	t_w	[Note]	cycles
Minimum Pulse Width, CLK	1	t_w	125	ns
Maximum Input Rise and Fall Times, CLK	1	t_r , t_f	100	μs

NOTE: The minimum limit is 3 REF_{in} cycles or 195 f_{in} cycles, whichever is greater.

MC145193

SWITCHING WAVEFORMS

Figure 1.

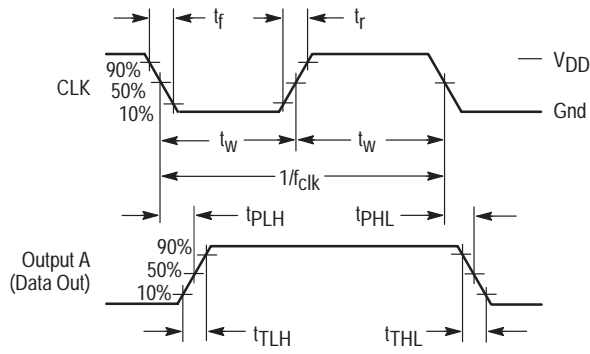

Figure 2.

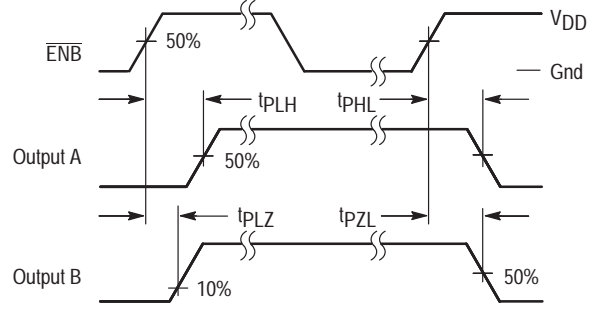

Figure 3.

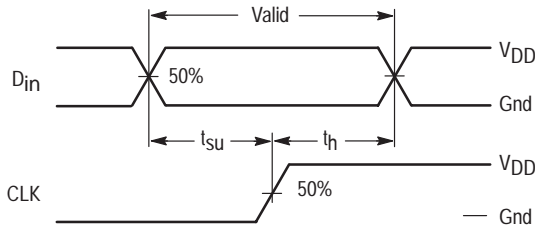

Figure 4.

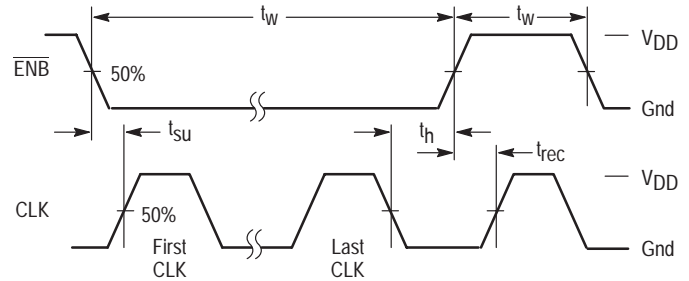
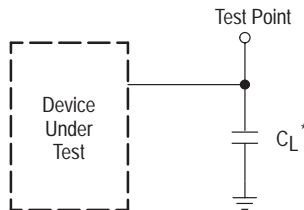
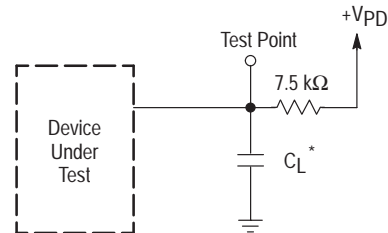

Figure 5.



* Includes all probe and fixture capacitance.

Figure 6.



* Includes all probe and fixture capacitance.

MC145193

LOOP SPECIFICATIONS ($V_{DD} = V_{CC} = 2.7$ to 5.5 V unless otherwise indicated, $T_A = -40$ to 85°C)

Parameter	Test Condition	Fig. No.	Symbol	Guaranteed Operating Range		Unit
				Min	Max	
Input Sensitivity Range, f_{in}	$100 \text{ MHz} \leq f_{in} \leq 1100 \text{ MHz}$	7	P_{in}	-10	4	dBm*
Input Frequency, REF_{in} Externally Driven in Reference Mode	$V_{in} \geq 400 \text{ mVpp}$ $2.7 \leq V_{DD} < 4.5 \text{ V}$ $4.5 \leq V_{DD} \leq 5.5 \text{ V}$	8	f_{ref}	1.5	20	MHz
Crystal Frequency, Crystal Mode	$C_1 \leq 30 \text{ pF}$, $C_2 \leq 30 \text{ pF}$, Includes Stray Capacitance	9	f_{XTAL}	2	15	MHz
Output Frequency, REF_{out}	$C_L = 20 \text{ pF}$, $V_{out} \geq 1 \text{ Vpp}$	10, 12	f_{out}	dc	10	MHz
Operating Frequency of the Phase Detectors			f_ϕ	dc	2	MHz
Output Pulse Width (ϕ_R , ϕ_V , and LD)	f_R in Phase with f_V , $C_L = 20 \text{ pF}$, ϕ_R and ϕ_V active for LD measurement, ** $V_{PD} = 2.7$ to 5.5 V $V_{DD} = 2.7 \text{ V}$ $V_{DD} = 4.5 \text{ V}$ $V_{DD} = 5.5 \text{ V}$	11, 12	t_w	40	120	ns
Output Transition Times (LD, ϕ_V , and ϕ_R)	$C_L = 20 \text{ pF}$, $V_{PD} = 2.7 \text{ V}$, $V_{DD} = V_{CC} = 2.7 \text{ V}$	11, 12	t_{TLH} , t_{THL}	—	80	ns
Input Capacitance, REF_{in}			C_{in}	—	7	pF

* Power level at the input to the dc block.

** When PD_{out} is active, LD minimum pulse width is approximately 5 ns.

Figure 7. Test Circuit

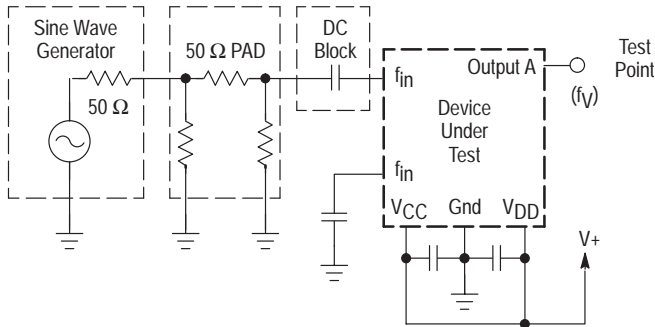

NOTE: Alternately, the 50 Ω pad may be a T network.

Figure 8. Test Circuit — Reference Mode

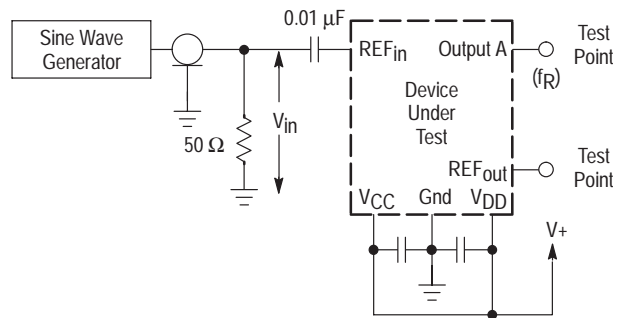

Figure 9. Test Circuit — Crystal Mode

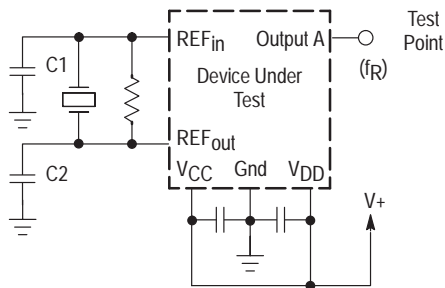

Figure 10. Switching Waveform

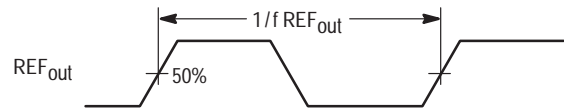

Figure 11. Switching Waveform

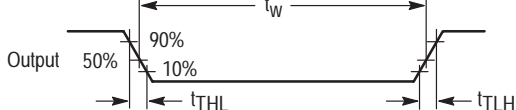
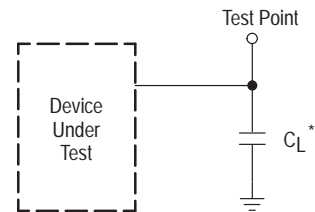

Figure 12. Test Circuit



* Includes all probe and fixture capacitance.

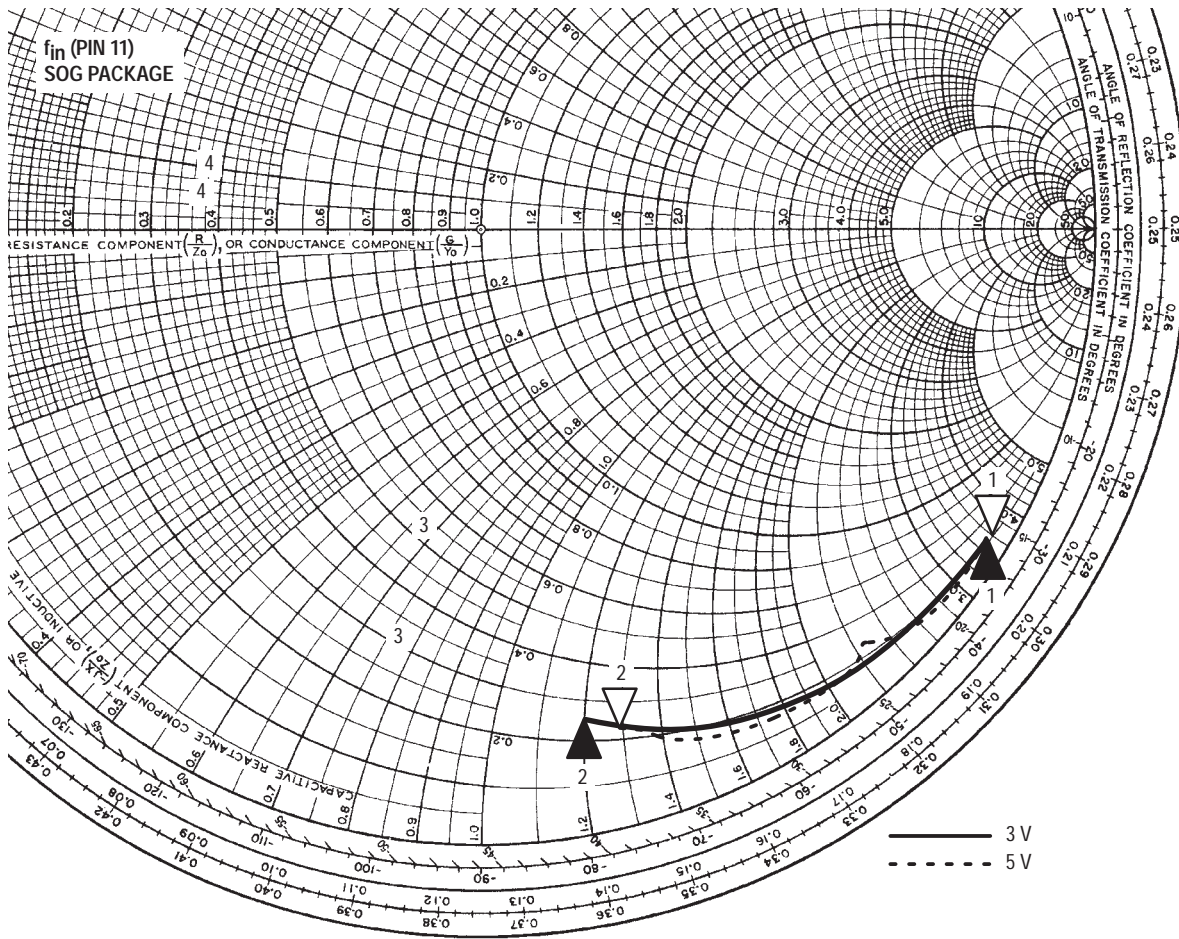

Figure 13. Normalized Input Impedance at f_{in} — Series Format ($R + jx$)

Table 1. Input Impedance at f_{in} — Series Format ($R + jx$), $V_{CC} = 3\text{ V}$

Marker	Frequency (GHz)	Resistance (Ω)	Reactance (Ω)	Capacitance/Inductance
1	0.5	11.4	-168	1.9 pF
2	1	12.4	-59.4	2.68 pF

Table 2. Input Impedance at f_{in} — Series Format ($R + jx$), $V_{CC} = 5\text{ V}$

Marker	Frequency (GHz)	Resistance (Ω)	Reactance (Ω)	Capacitance/Inductance
1	0.5	11.8	-175	1.82 pF
2	1	11.5	-64.4	2.47 pF

MC145193

PIN DESCRIPTIONS

DIGITAL INTERFACE PINS

D_{in} Serial Data Input (Pin 19)

The bit stream begins with the most significant bit (MSB) and is shifted in on the low-to-high transition of CLK. The bit pattern is 1 byte (8 bits) long to access the C or configuration register, 2 bytes (16 bits) to access the first buffer of the R register, or 3 bytes (24 bits) to access the A register (see Table 3). The values in the C, R, and A registers do not change during shifting because the transfer of data to the registers is controlled by $\overline{\text{ENB}}$.

CAUTION

The value programmed for the N counter must be greater than or equal to the value of the A counter.

The 13 least significant bits (LSBs) of the R register are double-buffered. As indicated above, data is latched into the first buffer on a 16-bit transfer. (The 3 MSBs are not double-buffered and have an immediate effect after a 16-bit transfer.) The second buffer of the R register contains the 13 bits for the R counter. This second buffer is loaded with the contents of the first buffer when the A register is loaded (a 24-bit transfer). This allows presenting new values to the R, A, and N counters simultaneously. If this is not required, then the 16-bit transfer may be followed by pulsing $\overline{\text{ENB}}$ low with no signal on the CLK pin. This is an alternate method of transferring data to the second buffer of the R register (see Figure 16).

The bit stream needs neither address nor steering bits due to the innovative BitGrabber Plus registers. Therefore, all bits in the stream are available to be data for the three registers. Random access of any register is provided (i.e., the registers may be accessed in any sequence). Data is retained in the registers over a supply range of 2.7 to 5.5 V. The formats are shown in Figures 14, 15, and 16.

D_{in} typically switches near 50% of V_{DD} to maximize noise immunity. This input can be directly interfaced to CMOS devices with outputs guaranteed to switch near rail-to-rail. When interfacing to NMOS or TTL devices, either a level shifter (MC74HC14A, MC14504B) or pull-up resistor of 1 k Ω to 10 k Ω must be used. Parameters to consider when sizing the resistor are worst-case I_{OL} of the driving device, maximum tolerable power consumption, and maximum data rate.

Table 3. Register Access

(MSBs are shifted in first; C0, R0, and A0 are the LSBs)

Number of Clocks	Accessed Register	Bit Nomenclature
8	C Register	C7, C6, C5, . . . , C0
16	R Register	R15, R14, R13, . . . , R0
24	A Register	A23, A22, A21, . . . , A0
Other Values \leq 32 Values $>$ 32	Not Allowed See Figures 22 – 25	

CLK Serial Data Clock Input (Pin 18)

Low-to-high transitions on CLK shift bits available at the D_{in} pin, while high-to-low transitions shift bits from Output A (when configured as Data Out, see Pin 16). The 24-1/2-stage shift register is static, allowing clock rates down to dc in a continuous or intermittent mode.

Eight clock cycles are required to access the C register. Sixteen clock cycles are needed for the first buffer of the R register. Twenty-four cycles are used to access the A register. See Table 3 and Figures 14, 15, and 16. The number of clocks required for cascaded devices is shown in Figures 23 through 25.

CLK typically switches near 50% of V_{DD} and has a Schmitt-triggered input buffer. Slow CLK rise and fall times are allowed. See the last paragraph of D_{in} for more information.

NOTE

To guarantee proper operation of the power-on reset (POR) circuit, the CLK pin must be held at Gnd (with $\overline{\text{ENB}}$ being a don't care) or $\overline{\text{ENB}}$ must be held at the potential of the V+ pin (with CLK being a don't care) during power-up. Floating, toggling, or having these pins in the wrong state during power-up does not harm the chip, but causes two potentially undesirable effects. First, the outputs of the device power up in an unknown state. Second, if two devices are cascaded, the A Registers must be written twice after power up. After these two accesses, the two cascaded chips perform normally.

$\overline{\text{ENB}}$ Active Low Enable Input (Pin 17)

This pin is used to activate the serial interface to allow the transfer of data to/from the device. When $\overline{\text{ENB}}$ is in an inactive high state, shifting is inhibited and the port is held in the initialized state. To transfer data to the device, $\overline{\text{ENB}}$ (which must start inactive high) is taken low, a serial transfer is made via D_{in} and CLK, and $\overline{\text{ENB}}$ is taken back high. The low-to-high transition on $\overline{\text{ENB}}$ transfers data to the C or A registers and first buffer of the R register, depending on the data stream length per Table 3.

Transitions on $\overline{\text{ENB}}$ must not be attempted while CLK is high. This puts the device out of synchronization with the microcontroller. Resynchronization occurs when $\overline{\text{ENB}}$ is high and CLK is low.

This input is also Schmitt-triggered and switches near 50% of V_{DD}, thereby minimizing the chance of loading erroneous data into the registers. See the last paragraph of D_{in} for more information.

For POR information, see the note for the CLK pin.

Output A**Configurable Digital Output (Pin 16)**

Output A is selectable as f_R , f_V , Data Out, or Port. Bits A22 and A23 in the A register control the selection; see Figure 15.

If A23 = A22 = high, Output A is configured as f_R . This signal is the buffered output of the 13-stage R counter. The f_R signal appears as normally low and pulses high. The f_R signal can be used to verify the divide ratio of the R counter. This ratio extends from 5 to 8191 and is determined by the binary value loaded into bits R0–R12 in the R register. Also, direct access to the phase detectors via the REF_{in} pin is allowed by choosing a divide value of 1 (see Figure 16). The maximum frequency at which the phase detectors operate is 2 MHz. Therefore, the frequency of f_R should not exceed 2 MHz.

If A23 = high and A22 = low, Output A is configured as f_V . This signal is the buffered output of the 12-stage N counter. The f_V signal appears as normally low and pulses high. The f_V signal can be used to verify the operation of the prescaler, A counter, and N counter. The divide ratio between the f_{in} input and the f_V signal is $N \times 64 + A$. N is the divide ratio of the N counter and A is the divide ratio of the A counter. These ratios are determined by bits loaded into the A register. See Figure 15. The maximum frequency at which the phase detectors operate is 2 MHz. Therefore, the frequency of f_V should not exceed 2 MHz.

If A23 = low and A22 = high, Output A is configured as Data Out. This signal is the serial output of the 24–1/2-stage shift register. The bit stream is shifted out on the high-to-low transition of the CLK input. Upon power up, Output A is automatically configured as Data Out to facilitate cascading devices.

If A23 = A22 = low, Output A is configured as Port. This signal is a general-purpose digital output which may be used as an MCU port expander. This signal is low when the Port bit (C1) of the C register is low, and high when the Port bit is high.

Output B**Open-Drain Digital Output (Pin 15)**

This signal is a general-purpose digital output which may be used as an MCU port expander. This signal is low when the Out B bit (C0) of the C register is low. When the Out B bit is high, Output B assumes the high-impedance state. Output B may be pulled up through an external resistor or active circuitry to any voltage less than or equal to the potential of the V_{PD} pin. **Note:** the maximum voltage allowed on the V_{PD} pin is 5.5 V.

Upon power-up, power-on reset circuitry forces Output B to a low level.

REFERENCE PINS **REF_{in} and REF_{out}** **Reference Input and Reference Output (Pins 20 and 1)**

Configurable pins for a Crystal or an External Reference. This pair of pins can be configured in one of two modes: the crystal mode or the reference mode. Bits R13, R14, and R15 in the R register control the modes as shown in Figure 16.

In crystal mode, these pins form a reference oscillator when connected to terminals of an external parallel-resonant

crystal. Frequency-setting capacitors of appropriate values, as recommended by the crystal supplier, are connected from each of the two pins to ground (up to a maximum of 30 pF each, including stray capacitance). An external resistor of 1 M Ω to 15 M Ω is connected directly across the pins to ensure linear operation of the amplifier. The required connections for the components are shown in Figure 9.

To turn on the oscillator, bits R15, R14, and R13 must have an octal value of one (001 in binary, respectively). This is the active-crystal mode shown in Figure 16. In this mode, the crystal oscillator runs and the R Counter divides the crystal frequency, unless the part is in standby. If the part is placed in standby via the C register, the oscillator runs, but the R counter is stopped. However, if bits R15 to R13 have a value of 0, the oscillator is stopped, which saves additional power. This is the shut-down crystal mode (shown in Figure 16) and can be engaged whether in standby or not.

In the reference mode, REF_{in} (Pin 20) accepts a signal from an external reference oscillator, such as a TCXO. A signal swinging from at least the V_{IL} to V_{IH} levels listed in the Electrical Characteristics table may be directly coupled to the pin. If the signal is less than this level, ac coupling must be used as shown in Figure 8. Due to an on-board resistor which is engaged in the reference modes, an external biasing resistor tied between REF_{in} and REF_{out} is not required.

With the reference mode, the REF_{out} pin is configured as the output of a divider. As an example, if bits R15, R14, and R13 have an octal value of seven, the frequency at REF_{out} is the REF_{in} frequency divided by 16. In addition, Figure 16 shows how to obtain ratios of eight, four, and two. A ratio of one-to-one can be obtained with an octal value of three. Upon power up, a ratio of eight is automatically initialized. The maximum frequency capability of the REF_{out} pin is listed in the Loop Specifications table for an output swing of 1 V_{pp} and 20 pF loads. Therefore, for higher REF_{in} frequencies, the one-to-one ratio may not be used for this magnitude of signal swing and loading requirements. Likewise, for REF_{in} frequencies above two times the highest rated frequency, the ratio must be more than two.

The output has a special on-board driver that has slew-rate control. This feature minimizes interference in the application.

If REF_{out} is unused, an octal value of two should be used for R15, R14, and R13 and the REF_{out} pin should be floated. A value of two allows REF_{in} to be functional while disabling REF_{out} , which minimizes dynamic power consumption.

LOOP PINS **f_{in} and $\overline{f_{in}}$
Frequency Inputs (Pins 11 and 10)**

These pins are frequency inputs from the VCO. These pins feed the on-board RF amplifier which drives the 64/65 prescaler. These inputs may be fed differentially. However, they are usually used in a single-ended configuration (shown in Figure 7). Note that f_{in} is driven while $\overline{f_{in}}$ must be tied to ground via a capacitor.

Motorola does not recommend driving $\overline{f_{in}}$ while terminating f_{in} because this configuration is not tested for sensitivity. The sensitivity is dependent on the frequency as shown in the Loop Specifications table.

PD_{out} Single-Ended Phase/Frequency Detector Output (Pin 6)

This is a three-state current-source/sink output for use as a loop error signal when combined with an external low-pass filter. The phase/frequency detector is characterized by a linear transfer function. The operation of the phase/frequency detector is described below and is shown in Figure 17.

POL bit (C7) in the C register = low (see Figure 14)

Frequency of $f_V > f_R$ or Phase of f_V Leading f_R : current-sinking pulses from a floating state

Frequency of $f_V < f_R$ or Phase of f_V Lagging f_R : current-sourcing pulses from a floating state

Frequency and Phase of $f_V = f_R$: essentially a floating state; voltage at pin determined by loop filter

POL bit (C7) = high

Frequency of $f_V > f_R$ or Phase of f_V Leading f_R : current-sourcing pulses from a floating state

Frequency of $f_V < f_R$ or Phase of f_V Lagging f_R : current-sinking pulses from a floating state

Frequency and Phase of $f_V = f_R$: essentially a floating state; voltage at pin determined by loop filter

This output can be enabled, disabled, and inverted via the C register. If desired, PD_{out} can be forced to the high-impedance state by utilization of the disable feature in the C register (bit C6). This is a patented feature. Similarly, PD_{out} is forced to the high-impedance state when the device is put into standby (STBY bit C4 = high).

The PD_{out} circuit is powered by V_{PD}. The phase detector gain is controllable by bits C3, C2, and C1: gain (in amps per radian) = PD_{out} current divided by 2π .

ϕ_R and ϕ_V (Pins 3 and 4) Double-Ended Phase/Frequency Detector Outputs

These outputs can be combined externally to generate a loop error signal. Through use of a Motorola patented technique, the detector's dead zone has been eliminated. Therefore, the phase/frequency detector is characterized by a linear transfer function. The operation of the phase/frequency detector is described below and is shown in Figure 17.

POL bit (C7) in the C register = low (see Figure 14)

Frequency of $f_V > f_R$ or Phase of f_V Leading f_R : ϕ_V = negative pulses, ϕ_R = essentially high

Frequency of $f_V < f_R$ or Phase of f_V Lagging f_R : ϕ_V = essentially high, ϕ_R = negative pulses

Frequency and Phase of $f_V = f_R$: ϕ_V and ϕ_R remain essentially high, except for a small minimum time period when both pulse low in phase

POL bit (C7) = high

Frequency of $f_V > f_R$ or Phase of f_V Leading f_R : ϕ_R = negative pulses, ϕ_V = essentially high

Frequency of $f_V < f_R$ or Phase of f_V Lagging f_R : ϕ_R = essentially high, ϕ_V = negative pulses

Frequency and Phase of $f_V = f_R$: ϕ_V and ϕ_R remain essentially high, except for a small minimum time period when both pulse low in phase

These outputs can be enabled, disabled, and interchanged via C register bits C6 or C4. This is a patented

feature. Note that when disabled or in standby, ϕ_R and ϕ_V are forced to their rest condition (high state).

The ϕ_R and ϕ_V output signal swing is approximately from Gnd to V_{PD}.

LD Lock Detector Output (Pin 2)

This output is essentially at a high level with narrow low-going pulses when the loop is locked (f_R and f_V of the same phase and frequency). The output pulses low when f_V and f_R are out of phase or different frequencies. LD is the logical ANDING of ϕ_R and ϕ_V (see Figure 17).

This output can be enabled and disabled via the C register. This is a patented feature. Upon power up, on-chip initialization circuitry disables LD to a static low logic level to prevent a false "lock" signal. If unused, LD should be disabled and left open.

The LD output signal swing is approximately from Gnd to V_{DD}.

Rx External Resistor (Pin 8)

A resistor tied between this pin and Gnd, in conjunction with bits in the C register, determines the amount of current that the PD_{out} pin sinks and sources. When bits C2 and C3 are both set high, the maximum current is obtained at PD_{out}; see Tables 4 and 5 for other current values. The recommended value for Rx is 3.9 k Ω (preliminary). A value of 3.9 k Ω provides current at the PD_{out} pin of approximately 1 mA @ V_{DD} = 3 V and approximately 1.7 mA @ V_{DD} = 5 V in the 100% current mode. Note that V_{DD}, not V_{PD}, is a factor in determining the current.

When the ϕ_R and ϕ_V outputs are used, the Rx pin may be floated.

Table 4. PD_{out} Current*, C1 = Low with Output A not Selected as "Port"; Also, Default Mode When Output A Selected as "Port"

Bit C3	Bit C2	PD _{out} Current*
0	0	70%
0	1	80%
1	0	90%
1	1	100%

* At the time the data sheet was printed, only the 100% current mode was guaranteed. The reduced current modes were for experimentation only.

Table 5. PD_{out} Current*, C1 = High with Output A not Selected as "Port"

Bit C3	Bit C2	PD _{out} Current*
0	0	25%
0	1	50%
1	0	75%
1	1	100%

* At the time the data sheet was printed, only the 100% current mode was guaranteed. The reduced current modes were for experimentation only.

MC145193

TEST POINT PINS

Test 1

Modulus Control Signal (Pin 9)

This pin may be used in conjunction with the Test 2 pin for access to the on-board 64/65 prescaler. When Test 1 is low, the prescaler divides by 65. When high, the prescaler divides by 64.

CAUTION

This pin is an unbuffered output and must be floated in an actual application. This pin must be attached to an isolated pad with no trace.

Test 2

Prescaler Output (Pin 13)

This pin may be used to access the on-board 64/65 prescaler output.

CAUTION

This pin is an unbuffered output and must be floated in an actual application. This pin must be attached to an isolated pad with no trace.

POWER SUPPLY PINS

VDD

Positive Power Supply (Pin 14)

This pin supplies power to the main CMOS digital portion of the device. Also, this pin, in conjunction with the Rx resistor, determines the internal reference current for the PD_{out} pin. The voltage range is 2.7 to 5.5 V with respect to the Gnd pin.

For optimum performance, VDD should be bypassed to Gnd using a low-inductance capacitor mounted very close to these pins. Lead lengths on the capacitor should be minimized.

VCC

Positive Power Supply (Pin 12)

This pin supplies power to the RF amp and 64/65 prescaler. The voltage range is 2.7 to 5.5 V with respect to the Gnd pin. In standby mode, the VCC pin still draws a few milliamps from the power supply. This current drain can be eliminated with the use of transistor Q1 as shown in Figure 21.

For optimum performance, VCC should be bypassed to Gnd using a low-inductance capacitor mounted very close to these pins. Lead lengths on the capacitor should be minimized.

V_{PD}

Positive Power Supply (Pin 5)

This pin supplies power to both phase/frequency detectors A and B. The voltage applied on this pin may be more or less than the potential applied to the VDD and VCC pins. The voltage range for V_{PD} is 2.7 to 5.5 V with respect to the Gnd pin.

For optimum performance, V_{PD} should be bypassed to Gnd using a low-inductance capacitor mounted very close to these pins. Lead lengths on the capacitor should be minimized.

Gnd

Ground (Pin 7)

Common ground.

MC145193

Figure 14. C Register Access and Format
(8 Clock Cycles are Used)

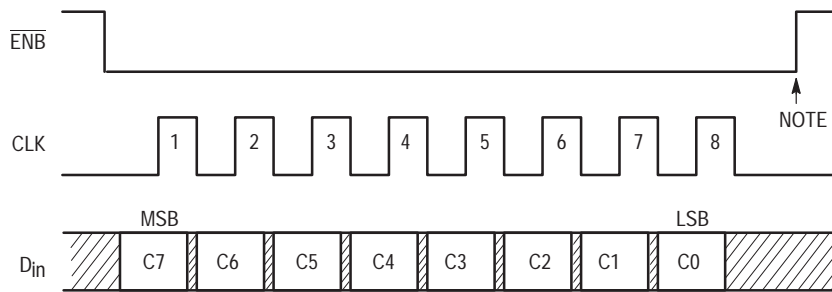

NOTE: At this point, the new byte is transferred to the C register and stored. No other registers are affected.

- C7 – POL: Selects the output polarity of the phase/frequency detectors. When set high, this bit inverts PD_{out} and interchanges the ϕ_{R} function with ϕ_{V} as depicted in Figure 17. Also see the phase detector output pin descriptions for more information. This bit is cleared low at power up.
- C6 – PDA/B: Selects which phase/frequency detector is to be used. When set high, enables the output of phase/frequency detector A (PD_{out}) and disables phase/frequency detector B by forcing ϕ_{R} and ϕ_{V} to the static high state. When cleared low, phase/frequency detector B is enabled (ϕ_{R} and ϕ_{V}) and phase/frequency detector A is disabled with PD_{out} forced to the high-impedance state. This bit is cleared low at power up.
- C5 – LDE: Enables the lock detector output when set high. When the bit is cleared low, the LD output is forced to a static low level. This bit is cleared low at power up.
- C4 – STBY: When set, places the CMOS section of device, which is powered by the V_{DD} and V_{PD} pins, in the standby mode for reduced power consumption: PD_{out} is forced to the high-impedance state, ϕ_{R} and ϕ_{V} are forced high, the A, N, and R counters are inhibited from counting, and the Rx current is shut off. In standby, the state of LD is determined by bit C5. C5 low forces LD low (no change). C5 high forces LD static high. During standby, data is retained in the A, R, and C registers. The condition of REF/OSC circuitry is determined by the control bits in the R register: R13, R14, and R15. However, if $\text{REF}_{\text{out}} = \text{static low}$ is selected, the internal feedback resistor is disconnected and the input is inhibited when in standby; in addition, the REF_{in} input only presents a capacitive load. NOTE: Standby does not affect the other modes of the REF/OSC circuitry.

When C4 is reset low, the part is taken out of standby in two steps. First, the REF_{in} (only in one mode) resistor is reconnected, all counters are enabled, and the Rx current is enabled. Any f_{R} and f_{V} signals are inhibited from toggling the phase/frequency detectors and lock detector. Second, when the first f_{V} pulse occurs, the R counter is jam loaded, and the phase/frequency and lock detectors are initialized. Immediately after the jam load, the A, N, and R counters begin counting down together. At this point, the f_{R} and f_{V} pulses are enabled to the phase and lock detectors. (Patented feature.)
- C3, C2 – I2, I1: Controls the PD_{out} source/sink current per Tables 4 and 5. With both bits high, the maximum current is available. Also, see C1 bit description.
- C1 – Port: When the Output A pin is selected as "Port" via bits A22 and A23, C1 determines the state of Output A. When C1 is set high, Output A is forced high; C1 low forces Output A low. When Output A is **not** selected as "Port," C1 controls whether the PD_{out} step size is 10% or 25%. (See Tables 4 and 5.) When low, steps are 10%. When high, steps are 25%. Default is 10% steps when Output A is selected as "Port." The Port bit is not affected by the standby mode.
- C0 – Out B: Determines the state of Output B. When C0 is set high, Output B is high-impedance; C0 low forces Output B low. The Out B bit is not affected by the standby mode. This bit is cleared low at power up.

MC145193

Figure 16. R Register Access and Format
(16 Clock Cycles are Used)

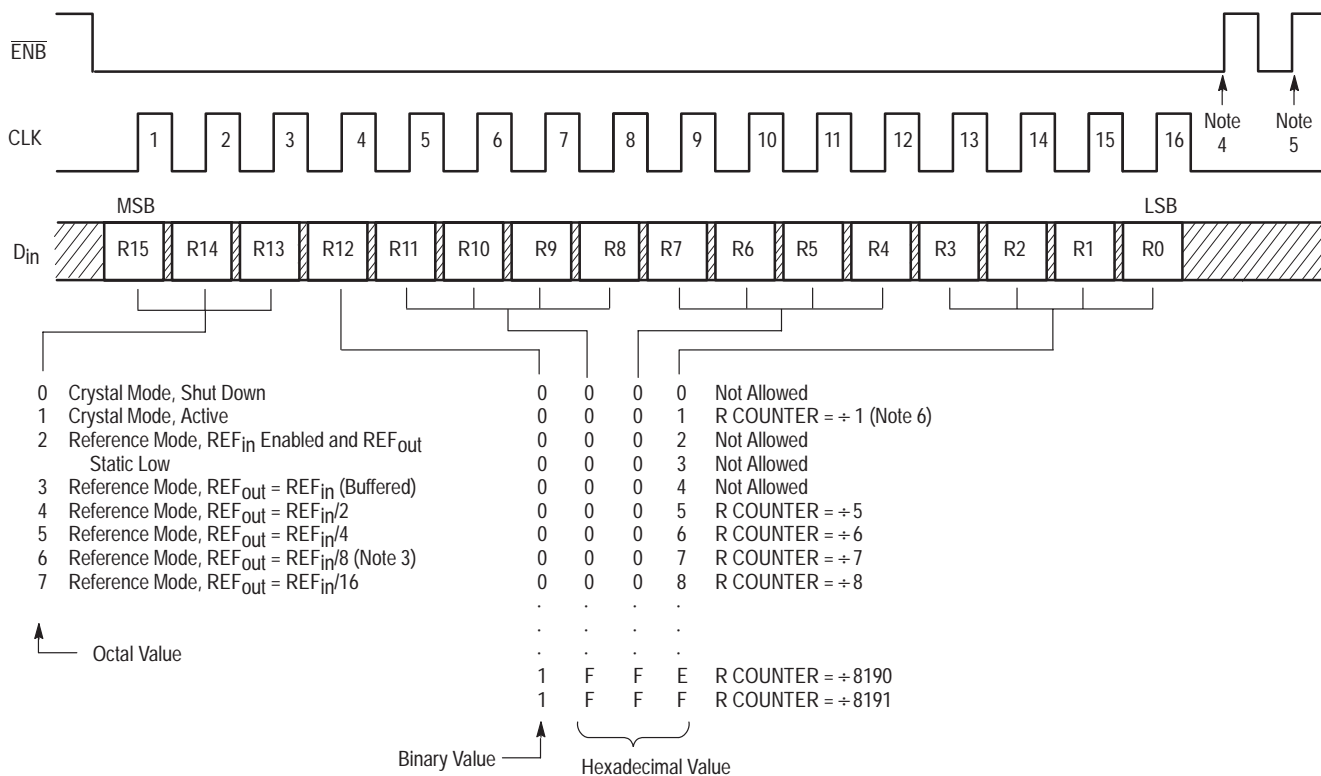

NOTES:

- 1 Bits R15 through R13 control the configurable “OSC or 4–stage divider” block (see Block Diagram).
- 2 Bits R12 through R0 control the “13–stage R counter” block (see Block Diagram).
- 3 A power–on initialize circuit forces a default REF_{in} to REF_{out} ratio of eight.
- 4 At this point, bits R13, R14, and R15 are stored and sent to the “OSC or 4–Stage Divider” block in the Block Diagram. Bits R0 – R12 are loaded into the first buffer in the double–buffered section of the R register. Therefore, the R counter divide ratio is not altered yet and retains the previous ratio loaded. The C and A registers are not affected.
- 5 Optional load pulse. At this point, bits R0 – R12 are transferred to the second buffer of the R register. The R counter begins dividing by the new ratio after completing the rest of the present count cycle. CLK must be low during the ENB pulse, as shown. The C and A registers are not affected. The first buffer of the R register is not affected. Also, see Note 3 of Figure 15 for an alternate method of loading the second buffer in the R register.
- 6 Allows direct access to reference input of phase/frequency detectors.

Figure 17. Phase/Frequency Detectors and Lock Detector Output Waveforms

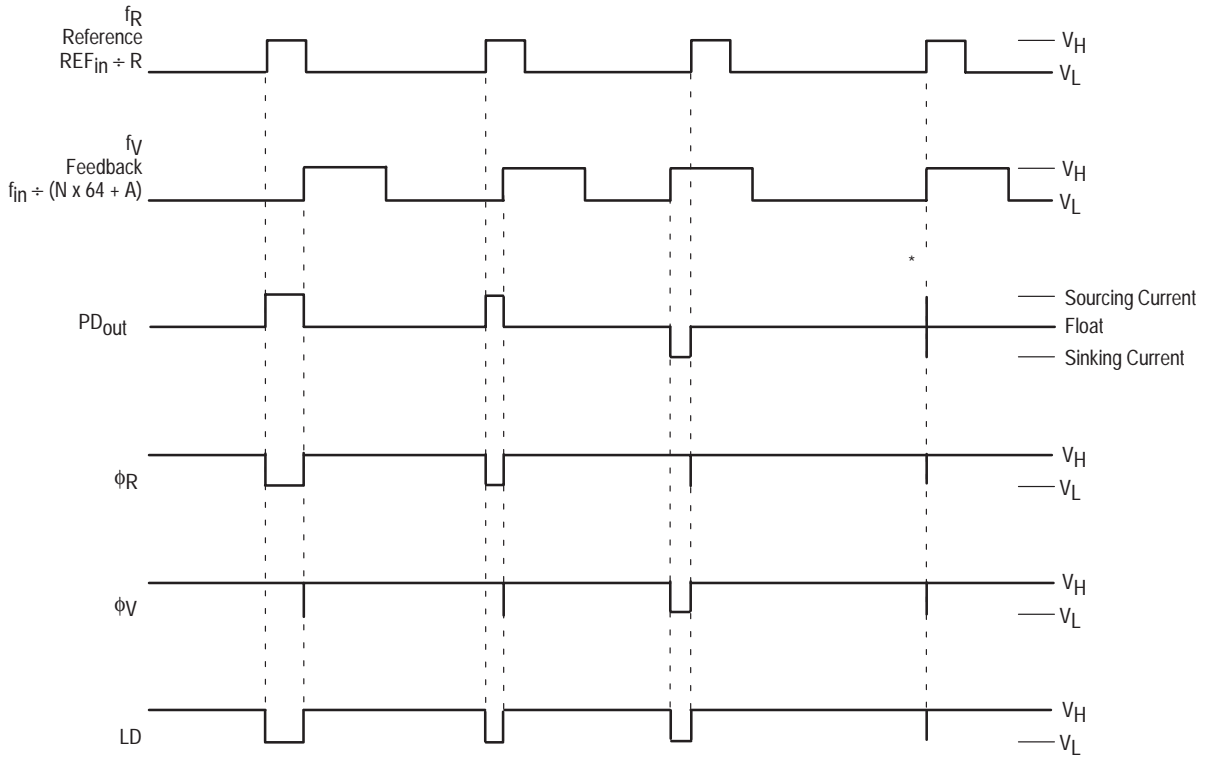

V_H = High voltage level

V_L = Low voltage level

*At this point, when both f_R and f_V are in phase, the output source and sink circuits are turned on for a short interval.

NOTE: The PD_{out} either sources or sinks current during out-of-lock conditions. When locked in phase and frequency, the output is in the floating condition and the voltage at that pin is determined by the low-pass filter capacitor. PD_{out} , ϕ_R , and ϕ_V are shown with the polarity bit (POL) = low; see Figure 14 for POL.

DESIGN CONSIDERATIONS

Crystal Oscillator Considerations

The following options may be considered to provide a reference frequency to Motorola's CMOS frequency synthesizers.

Use of a Hybrid Crystal Oscillator

Commercially available temperature-compensated crystal oscillators (TCXOs) or crystal-controlled data clock oscillators provide very stable reference frequencies. An oscillator capable of CMOS logic levels at the output may be direct or dc coupled to REF_{in}. If the oscillator does not have CMOS logic levels on the outputs, capacitive or ac coupling to REF_{in} may be used (see Figure 8).

For additional information about TCXOs and data clock oscillators, please consult the latest version of the *eem Electronic Engineers Master Catalog*, the *Gold Book*, or similar publications.

Design an Off-Chip Reference

The user may design an off-chip crystal oscillator using discrete transistors or ICs specifically developed for crystal oscillator applications. The reference signal is usually ac coupled to REF_{in} (see Figure 8). For large amplitude signals (standard CMOS logic levels), dc coupling may be used.

Use of the On-Chip Oscillator Circuitry

The on-chip amplifier (a digital inverter) along with an appropriate crystal may be used to provide a reference source frequency. A fundamental mode crystal, parallel resonant at the desired operating frequency, should be connected as shown in Figure 18.

The crystal should be specified for a loading capacitance (C_L) which does not exceed approximately 20 pF when used at the highest operating frequencies listed in the Loop Specifications table. Assuming R1 = 0 Ω, the shunt load capacitance (C_L) presented across the crystal can be estimated to be:

$$C_L = \frac{C_{in}C_{out}}{C_{in} + C_{out}} + C_a + C_{stray} + \frac{C_1 \cdot C_2}{C_1 + C_2}$$

where

C_{in} = 5 pF (see Figure 19)

C_{out} = 6 pF (see Figure 19)

C_a = 1 pF (see Figure 19)

C1 and C2 = external capacitors (see Figure 18)

C_{stray} = the total equivalent external circuit stray capacitance appearing across the crystal terminals

The oscillator can be "trimmed" on-frequency by making a portion or all of C1 variable. The crystal and associated components must be located as close as possible to the REF_{in} and REF_{out} pins to minimize distortion, stray capacitance, stray inductance, and startup stabilization time. Circuit stray capacitance can also be handled by adding the appropriate stray value to the values for C_{in} and C_{out}. For this approach, the term C_{stray} becomes 0 in the above expression for C_L.

Power is dissipated in the effective series resistance of the crystal, R_e, in Figure 20. The maximum drive level specified by the crystal manufacturer represents the maximum stress that the crystal can withstand without damage or excessive

shift in operating frequency. R1 in Figure 18 limits the drive level. The use of R1 is not necessary in most cases.

To verify that the maximum dc supply voltage does not cause the crystal to be overdriven, monitor the output frequency (f_R) at Output A as a function of supply voltage. (REF_{out} is not used because loading impacts the oscillator.) The frequency should increase very slightly as the dc supply voltage is increased. An overdriven crystal decreases in frequency or becomes unstable with an increase in supply voltage. The operating supply voltage must be reduced or R1 must be increased in value if the overdriven condition exists. The user should note that the oscillator start-up time is proportional to the value of R1.

Through the process of supplying crystals for use with CMOS inverters, many crystal manufacturers have developed expertise in CMOS oscillator design with crystals. Discussions with such manufacturers can prove very helpful (see Table 6).

Figure 18. Pierce Crystal Oscillator Circuit

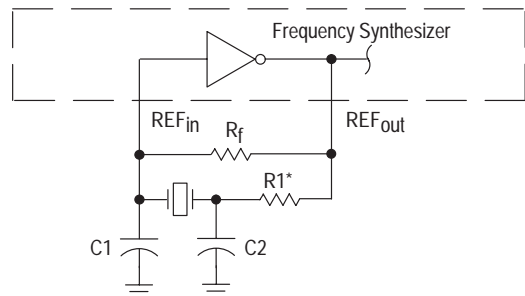

* May be needed in certain cases. See text.

Figure 19. Parasitic Capacitances of the Amplifier and C_{stray}

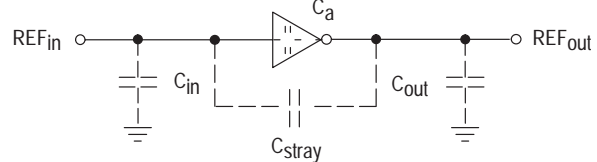
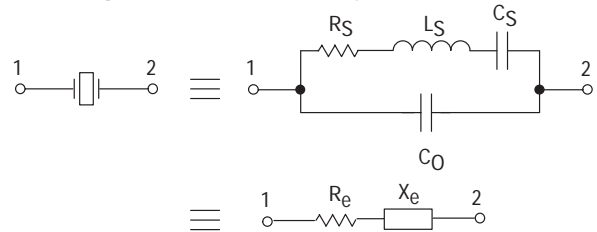

Figure 20. Equivalent Crystal Networks



NOTE: Values are supplied by crystal manufacturer (parallel resonant crystal).

MC145193

RECOMMENDED READING

Technical Note TN-24, Statek Corp.

Technical Note TN-7, Statek Corp.

E. Hafner, "The Piezoelectric Crystal Unit—Definitions and Method of Measurement", *Proc. IEEE*, Vol. 57, No. 2, Feb. 1969.

D. Kemper, L. Rosine, "Quartz Crystals for Frequency Control", *Electro-Technology*, June 1969.

P. J. Ottowitz, "A Guide to Crystal Selection", *Electronic Design*, May 1966.

D. Babin, "Designing Crystal Oscillators", *Machine Design*, March 7, 1985.

D. Babin, "Guidelines for Crystal Oscillator Design", *Machine Design*, April 25, 1985.

Table 6. Partial List of Crystal Manufacturers

CTS Corp.
United States Crystal Corp.
Crystek Crystal
Statek Corp.
Fox Electronics

NOTE: Motorola cannot recommend one supplier over another and in no way suggests that this is a complete listing of crystal manufacturers.

PHASE-LOCKED LOOP — LOW-PASS FILTER DESIGN

(A)

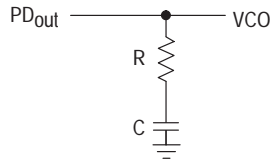

$$\omega_n = \sqrt{\frac{K_\phi K_{VCO}}{NC}}$$

$$\zeta = \frac{R}{2} \sqrt{\frac{K_\phi K_{VCO} C}{N}} = \frac{\omega_n RC}{2}$$

$$Z(s) = \frac{1 + sRC}{sC}$$

NOTE:

For (A), using K_ϕ in amps per radian with the filter's impedance transfer function, $Z(s)$, maintains units of volts per radian for the detector/filter combination. Additional sideband filtering can be accomplished by adding a capacitor C' across R . The corner $\omega_c = 1/RC'$ should be chosen such that ω_n is not significantly affected.

(B)

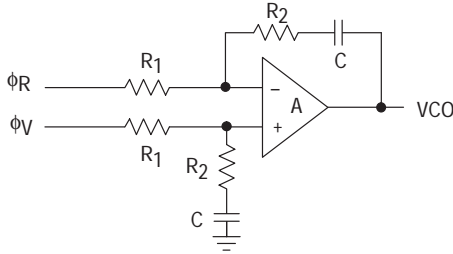

$$\omega_n = \sqrt{\frac{K_\phi K_{VCO}}{NCR_1}}$$

$$\zeta = \frac{\omega_n R_2 C}{2}$$

Assuming Gain A is very large, then:

$$F(s) = \frac{R_2 s C + 1}{R_1 s C}$$

NOTE:

For (B), R_1 is frequently split into two series resistors; each resistor is equal to R_1 divided by 2. A capacitor C_C is then placed from the midpoint to ground to further filter the error pulses. The value of C_C should be such that the corner frequency of this network does not significantly affect ω_n .

DEFINITIONS:

N = Total Division Ratio in Feedback Loop

K_ϕ (Phase Detector Gain) = $I_{PDout}/2\pi$ amps per radian for PD_{out}

K_ϕ (Phase Detector Gain) = $V_{PD}/2\pi$ volts per radian for ϕ_V and ϕ_R

K_{VCO} (VCO Transfer Function) = $\frac{2\pi\Delta f_{VCO}}{\Delta V_{VCO}}$ radians per volt

For a nominal design starting point, the user might consider a damping factor $\zeta \approx 0.7$ and a natural loop frequency $\omega_n \approx (2\pi f_R/50)$ where f_R is the frequency at the phase detector input. Larger ω_n values result in faster loop lock times and, for similar sideband filtering, higher f_R -related VCO sidebands.

Either loop filter (A) or (B) is frequently followed by additional sideband filtering to further attenuate f_R -related VCO sidebands. This additional filtering may be active or passive.

RECOMMENDED READING:

Gardner, Floyd M., *Phaselock Techniques (second edition)*. New York, Wiley-Interscience, 1979.
 Manassewitsch, Vadim, *Frequency Synthesizers: Theory and Design (second edition)*. New York, Wiley-Interscience, 1980.
 Blanchard, Alain, *Phase-Locked Loops: Application to Coherent Receiver Design*. New York, Wiley-Interscience, 1976.
 Egan, William F., *Frequency Synthesis by Phase Lock*. New York, Wiley-Interscience, 1981.
 Rohde, Ulrich L., *Digital PLL Frequency Synthesizers Theory and Design*. Englewood Cliffs, NJ, Prentice-Hall, 1983.
 Berlin, Howard M., *Design of Phase-Locked Loop Circuits, with Experiments*. Indianapolis, Howard W. Sams and Co., 1978.
 Kinley, Harold, *The PLL Synthesizer Cookbook*. Blue Ridge Summit, PA, Tab Books, 1980.
 Seidman, Arthur H., *Integrated Circuits Applications Handbook*, Chapter 17, pp. 538-586. New York, John Wiley & Sons.
 Fadrhons, Jan, "Design and Analyze PLLs on a Programmable Calculator," *EDN*. March 5, 1980.
 AN535, Phase-Locked Loop Design Fundamentals, Motorola Semiconductor Products, Inc., 1970.
 AR254, Phase-Locked Loop Design Articles, Motorola Semiconductor Products, Inc., Reprinted with permission from *Electronic Design*, 1987.
 AN1253, An Improved PLL Design Method Without ω_n and ζ , Motorola Semiconductor Products, Inc., 1995.

MC145193

Figure 21. Example Application

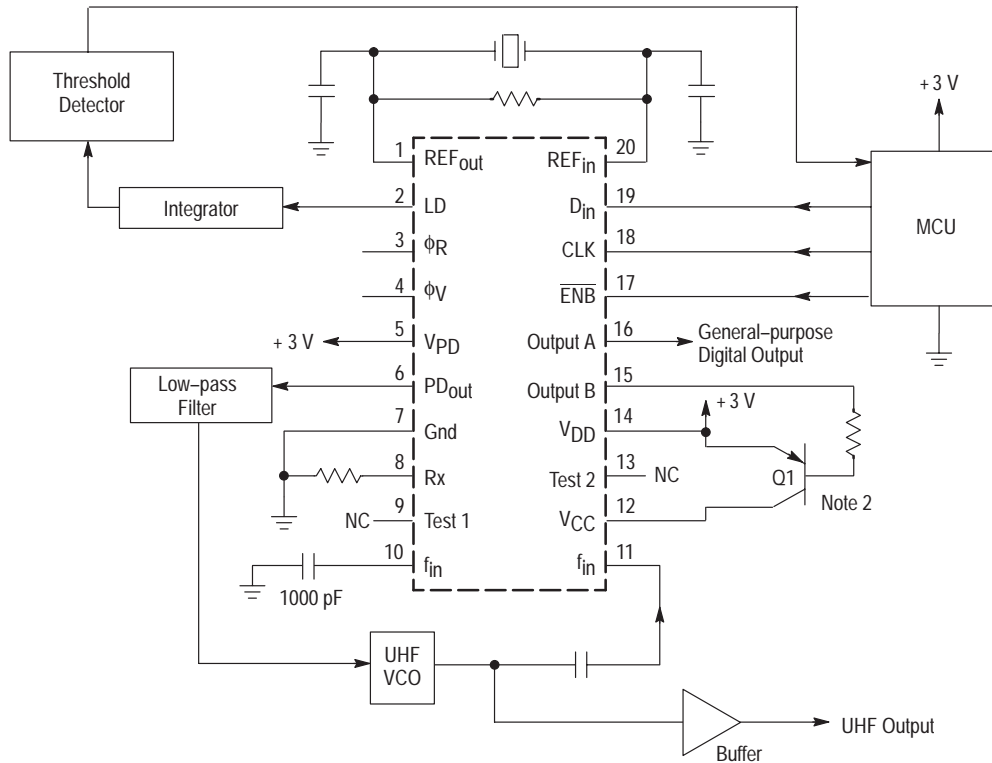

NOTES:

- 1 When used, the ϕ_R and ϕ_V outputs are fed to an external combiner/loop filter. See the Phase-Locked Loop — Low-Pass Filter Design (Page 19) for additional information.
- 2 Transistor Q1 is required only if the standby feature is needed. Q1 permits the bipolar section of the device to be shut down via use of the general-purpose digital pin, Output B. If the standby feature is not needed, tie Pin 12 directly to the power supply.
- 3 For optimum performance, bypass the V_{CC} , V_{DD} , and V_{PD} pins to Gnd with low-inductance capacitors.
- 4 The R counter is programmed for a divide value = REF_{in} / f_R . Typically, f_R is the tuning resolution required for the VCO. Also, the VCO frequency divided by $f_R = N_T = N \times 64 + A$; this determines the values (N, A) that must be programmed into the N and A counters, respectively.

Figure 22. Cascading Two Devices

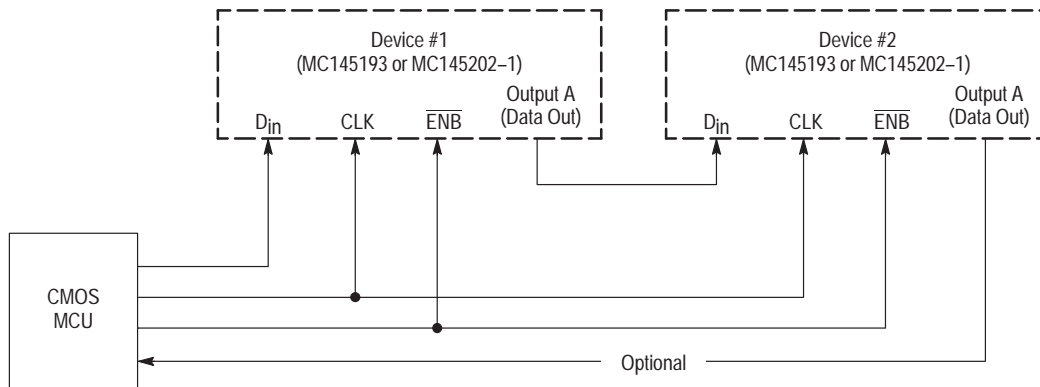

NOTE: See related Figures 23, 24, and 25.

Figure 23. Accessing the C Registers of Two Cascaded MC145193 or MC145202-1 Devices

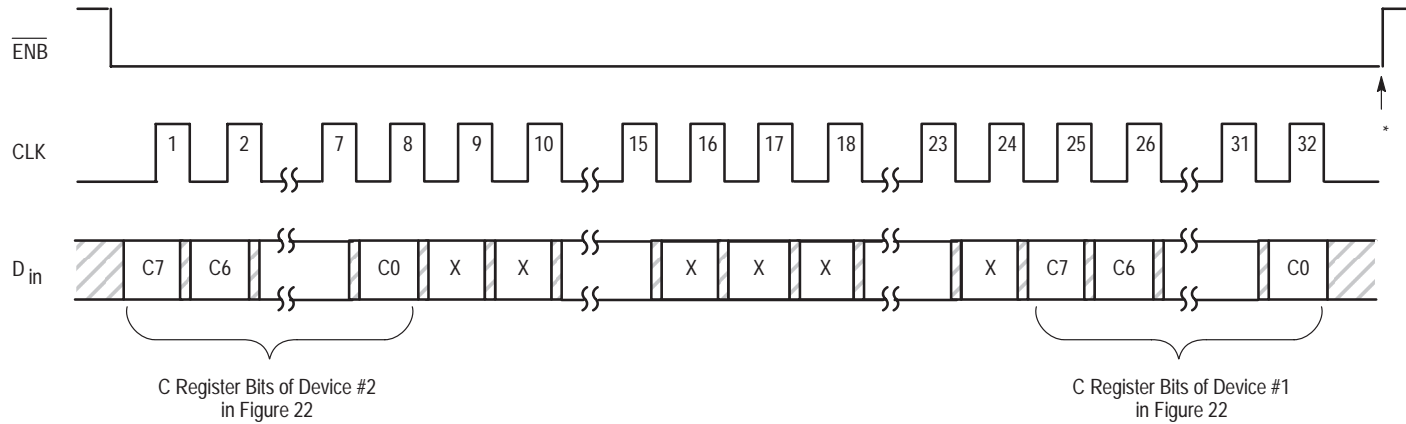

*At this point, the new bytes are transferred to the C registers of both devices and stored. No other registers are affected.

Figure 24. Accessing the A Registers of Two Cascaded MC145193 or MC145202-1 Devices

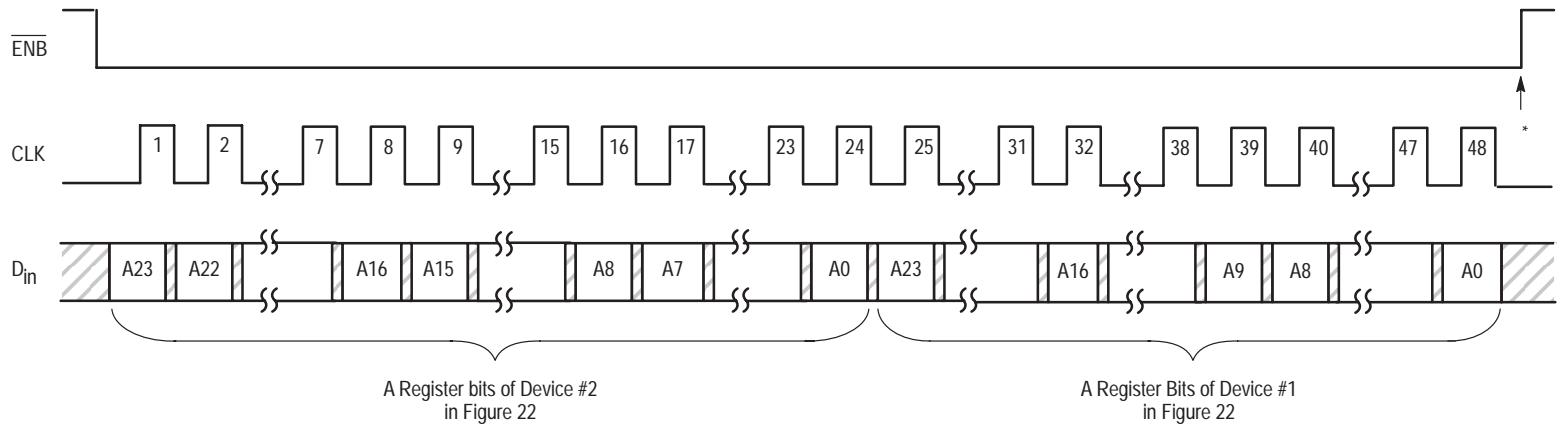

* At this point, the new bytes are transferred to the A registers of both devices and stored. Additionally, for both devices, the 13 LSBs in each of the first buffers of the R registers are transferred to the respective R register's second buffer. Thus, the R, N, and A counter can be presented new divide ratios at the same time. The first buffer of each R register is not affected. Neither C register is affected.

Figure 25. Accessing the R Registers of Two Cascaded MC145193 or MC145202-1 Devices

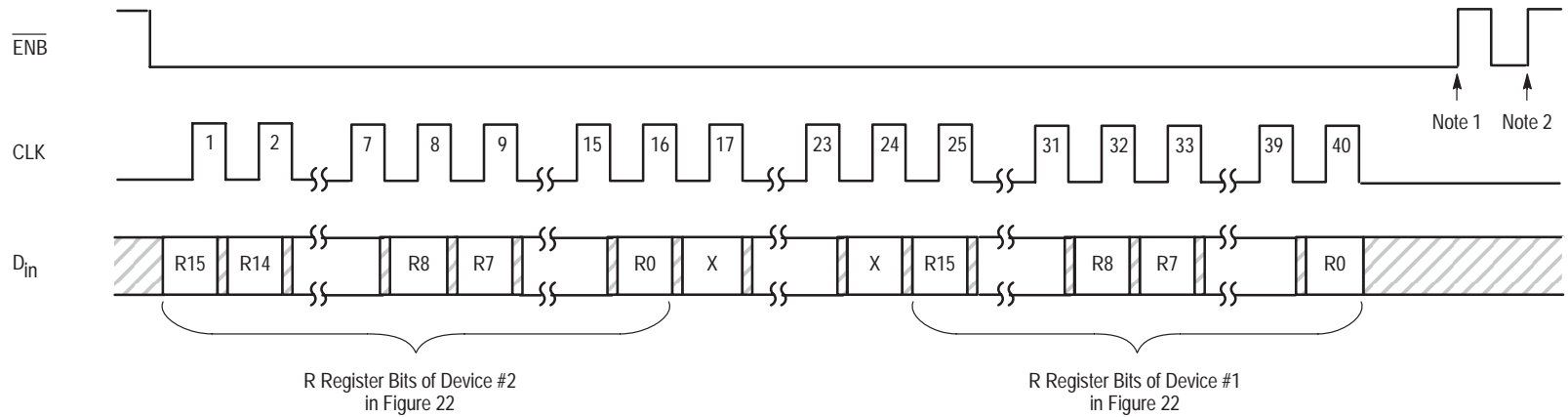

Notes Applicable to Each Device:

1. At this point, bits R13, R14 and R15 are stored and sent to the "OSC or 4-Stage Divider" block in the Block Diagram. Bits R0 through R12 are loaded into the first buffer in the double-buffered section of the R register. Therefore, the R counter divide is not altered yet and retains the previous ratio loaded. The C and A registers are not affected.
2. Optional load pulse. At this point, the bits R0 through R12 are transferred to the second buffer of the R register. The R counter begins dividing by the new ratio after completing the rest of the present count cycle. CLK must be low during the $\overline{\text{ENB}}$ pulse, as shown. The C and A registers are not affected. The first buffer of the R register is not affected. Also, see note of Figure 24 for an alternate method of loading the second buffer in the R register.

MC145193

OUTLINE DIMENSIONS

F SUFFIX
 PLASTIC PACKAGE
 CASE 751J-02
 (SO-20)
 ISSUE A

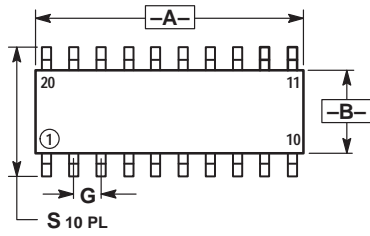

⊕ 0.13 (0.005) (M) B (M)

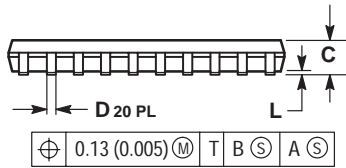

⊕ 0.13 (0.005) (M) T B (S) A (S)

0.10 (0.004)
 -T- SEATING PLANE

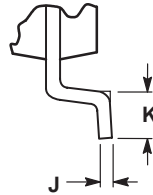
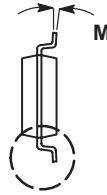

NOTES:

1. DIMENSIONING AND TOLERANCING PER ANSI Y14.5M, 1982.
2. CONTROLLING DIMENSION: MILLIMETER.
3. DIMENSIONS A AND B DO NOT INCLUDE MOLD PROTRUSION.
4. MAXIMUM MOLD PROTRUSION 0.12 (0.006) PER SIDE.
5. DIMENSION D DOES NOT INCLUDE DAMBAR PROTRUSION. ALLOWABLE DAMBAR PROTRUSION SHALL BE 0.13 (0.005) TOTAL IN EXCESS OF THE D DIMENSION AT MAXIMUM MATERIAL CONDITION.

DIM	MILLIMETERS		INCHES	
	MIN	MAX	MIN	MAX
A	12.55	12.80	0.494	0.504
B	5.10	5.40	0.201	0.213
C	---	2.00	---	0.079
D	0.35	0.45	0.014	0.018
G	1.27 BSC		0.050 BSC	
J	0.18	0.23	0.007	0.009
K	0.55	0.85	0.022	0.033
L	0.05	0.20	0.002	0.008
M	0°	7°	0°	7°
S	7.40	8.20	0.291	0.323

Motorola reserves the right to make changes without further notice to any products herein. Motorola makes no warranty, representation or guarantee regarding the suitability of its products for any particular purpose, nor does Motorola assume any liability arising out of the application or use of any product or circuit, and specifically disclaims any and all liability, including without limitation consequential or incidental damages. "Typical" parameters which may be provided in Motorola data sheets and/or specifications can and do vary in different applications and actual performance may vary over time. All operating parameters, including "Typicals" must be validated for each customer application by customer's technical experts. Motorola does not convey any license under its patent rights nor the rights of others. Motorola products are not designed, intended, or authorized for use as components in systems intended for surgical implant into the body, or other applications intended to support or sustain life, or for any other application in which the failure of the Motorola product could create a situation where personal injury or death may occur. Should Buyer purchase or use Motorola products for any such unintended or unauthorized application, Buyer shall indemnify and hold Motorola and its officers, employees, subsidiaries, affiliates, and distributors harmless against all claims, costs, damages, and expenses, and reasonable attorney fees arising out of, directly or indirectly, any claim of personal injury or death associated with such unintended or unauthorized use, even if such claim alleges that Motorola was negligent regarding the design or manufacture of the part. Motorola and  are registered trademarks of Motorola, Inc. Motorola, Inc. is an Equal Opportunity/Affirmative Action Employer.

How to reach us:

USA/EUROPE/Locations Not Listed: Motorola Literature Distribution;
P.O. Box 5405, Denver, Colorado 80217. 1-303-675-2140 or 1-800-441-2447

JAPAN: Motorola Japan Ltd.; SPS, Technical Information Center, 3-20-1,
Minami-Azabu, Minato-ku, Tokyo 106-8573 Japan. 81-3-3440-3569

Technical Information Center: 1-800-521-6274

ASIA/PACIFIC: Motorola Semiconductors H.K. Ltd.; Silicon Harbour Centre,
2, Dai King Street, Tai Po Industrial Estate, Tai Po, N.T., Hong Kong.
852-26668334

HOME PAGE: <http://www.motorola.com/semiconductors/>



MOTOROLA

