

MSP430x20x1, MSP430x20x2, MSP430x20x3 MIXED SIGNAL MICROCONTROLLER

SLAS491A – AUGUST 2005 – REVISED OCTOBER 2005

- Low Supply Voltage Range 1.8 V to 3.6 V
- Ultralow-Power Consumption
 - Active Mode: 220 μ A at 1 MHz, 2.2 V
 - Standby Mode: 0.5 μ A
 - Off Mode (RAM Retention): 0.1 μ A
- Five Power-Saving Modes
- Ultrafast Wake-Up From Standby Mode in less than 1 μ s
- 16-Bit RISC Architecture, 62.5 ns Instruction Cycle Time
- Basic Clock Module Configurations:
 - Internal Frequencies up to 16MHz with 4 Calibrated Frequencies to \pm 1%
 - Internal Very Low Power LF oscillator
 - 32-kHz Crystal
 - External Digital Clock Source
- 16-Bit Timer_A With Two Capture/Compare Registers
- On-Chip Comparator for Analog Signal Compare Function or Slope A/D (MSP430x20x1 only)
- 10-Bit, 200-ksps A/D Converter with Internal Reference, Sample-and-Hold, and Autoscan. (MSP430x20x2 only)
- 16-Bit Sigma-Delta A/D Converter with Differential PGA Inputs, and Internal Reference (MSP430x20x3 only)
- Universal Serial Interface (USI), supporting SPI and I2C (MSP430x20x2 and MSP430x20x3 only)
- Brownout Detector
- Serial Onboard Programming, No External Programming Voltage Needed Programmable Code Protection by Security Fuse
- On-Chip Emulation Logic with Spy-Bi-Wire Interface
- Family Members Include:
 - MSP430F2001†: 1KB + 256B Flash Memory 128B RAM
 - MSP430F2011†: 2KB + 256B Flash Memory 128B RAM
 - MSP430F2002†: 1KB + 256B Flash Memory 128B RAM
 - MSP430F2012†: 2KB + 256B Flash Memory 128B RAM
 - MSP430F2003: 1KB + 256B Flash Memory 128B RAM
 - MSP430F2013: 2KB + 256B Flash Memory 128B RAM
- Available in a 14-Pin Plastic Small-Outline Thin Package (TSSOP), 14-Pin Plastic Dual Inline Package (PDIP), and 16-Pin QFN
- For Complete Module Descriptions, Refer to the *MSP430x2xx Family User's Guide*

† Product Preview

description

The Texas Instruments MSP430 family of ultralow power microcontrollers consist of several devices featuring different sets of peripherals targeted for various applications. The architecture, combined with five low power modes is optimized to achieve extended battery life in portable measurement applications. The device features a powerful 16-bit RISC CPU, 16-bit registers, and constant generators that attribute to maximum code efficiency. The digitally controlled oscillator (DCO) allows wake-up from low-power modes to active mode in less than 1 μ s.

The MSP430x20xx series is an ultralow-power mixed signal microcontroller with a built-in 16-bit timer, and ten I/O pins. In addition the MSP430x20x1 has a versatile analog comparator. The MSP430x20x2 and MSP430x20x3 have built-in communication capability using synchronous protocols (SPI or I2C), and a 10-bit A/D converter (MSP430x20x2) or a 16-bit sigma-delta A/D converter (MSP430x20x3).

Typical applications include sensor systems that capture analog signals, convert them to digital values, and then process the data for display or for transmission to a host system. Stand alone RF sensor front end is another area of application.



Please be aware that an important notice concerning availability, standard warranty, and use in critical applications of Texas Instruments semiconductor products and disclaimers thereto appears at the end of this data sheet.

PRODUCTION DATA information is current as of publication date. Products conform to specifications per the terms of Texas Instruments standard warranty. Production processing does not necessarily include testing of all parameters.



POST OFFICE BOX 655303 • DALLAS, TEXAS 75265

Copyright © 2005 Texas Instruments Incorporated

MSP430x20x1, MSP430x20x2, MSP430x20x3 MIXED SIGNAL MICROCONTROLLER

SLAS491A – AUGUST 2005 – REVISED OCTOBER 2005

AVAILABLE OPTIONS

T _A	PACKAGED DEVICES		
	PLASTIC 14-PIN TSSOP (PW)	PLASTIC 14-PIN DIP† (N)	PLASTIC 16-PIN QFN (RSA)
-40°C to 85°C	MSP430F2001IPW† MSP430F2011IPW† MSP430F2002IPW† MSP430F2012IPW† MSP430F2003IPW MSP430F2013IPW	MSP430F2001IN† MSP430F2011IN† MSP430F2002IN† MSP430F2012IN† MSP430F2003IN† MSP430F2013IN†	MSP430F2001IRSA† MSP430F2011IRSA† MSP430F2002IRSA† MSP430F2012IRSA† MSP430F2003IRSA† MSP430F2013IRSA†

† Product Preview

device pinout, MSP430x20x1

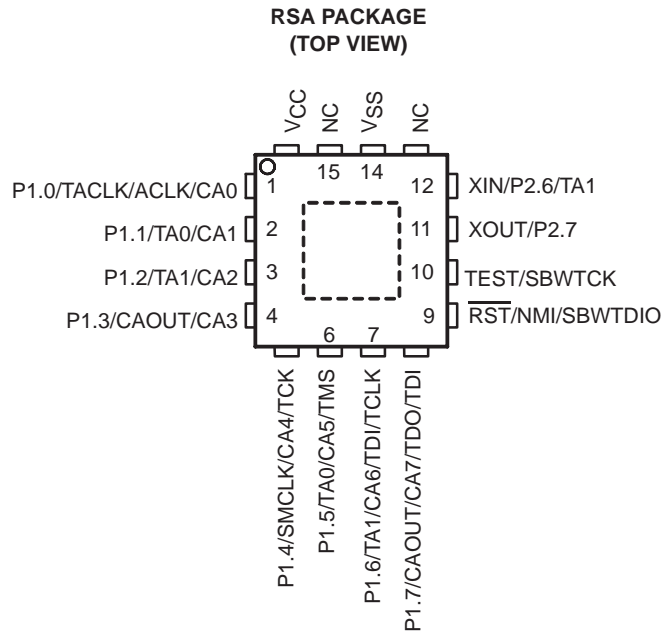
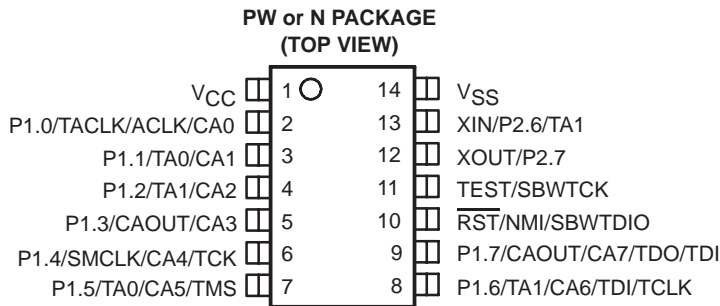

MSP430x20x1, MSP430x20x2, MSP430x20x3 MIXED SIGNAL MICROCONTROLLER

SLAS491A – AUGUST 2005 – REVISED OCTOBER 2005

device pinout, MSP430x20x2

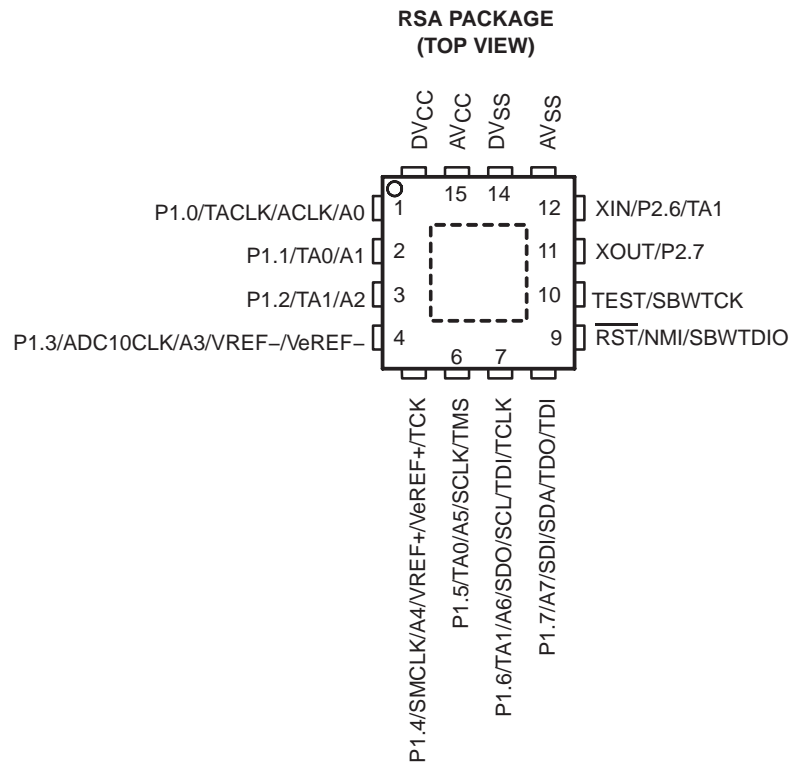
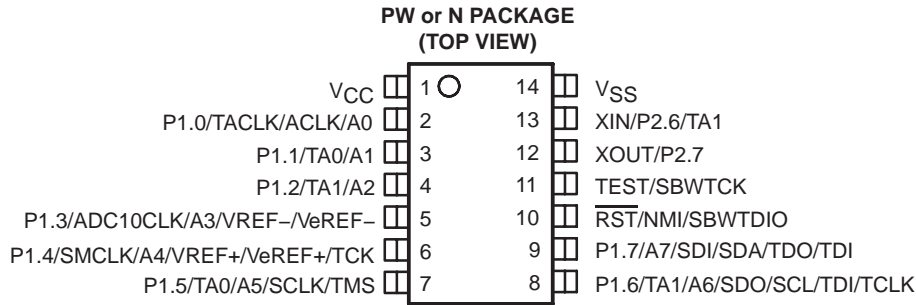

MSP430x20x1, MSP430x20x2, MSP430x20x3 MIXED SIGNAL MICROCONTROLLER

SLAS491A – AUGUST 2005 – REVISED OCTOBER 2005

functional block diagram, MSP430x20x1

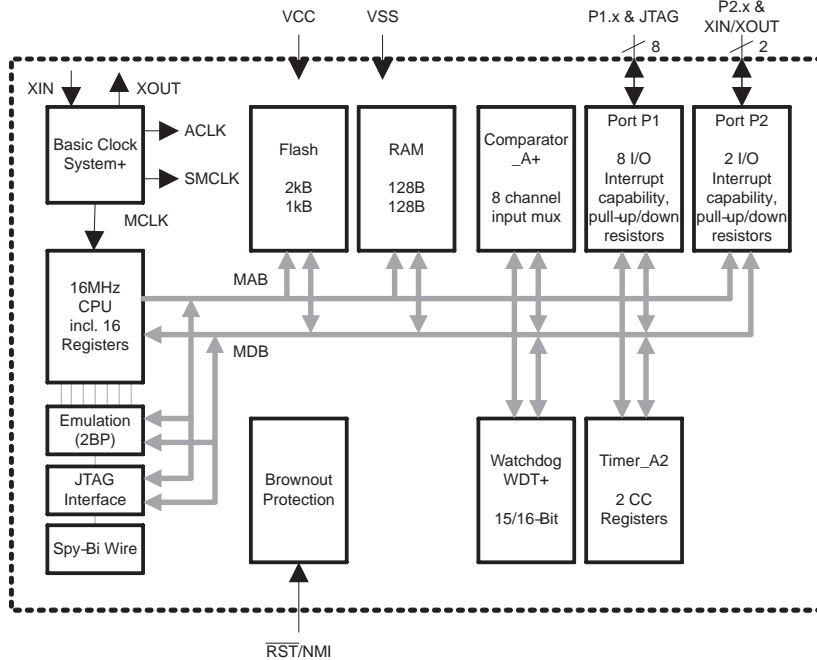

NOTE: See port schematics section for detailed I/O information.

functional block diagram, MSP430x20x2

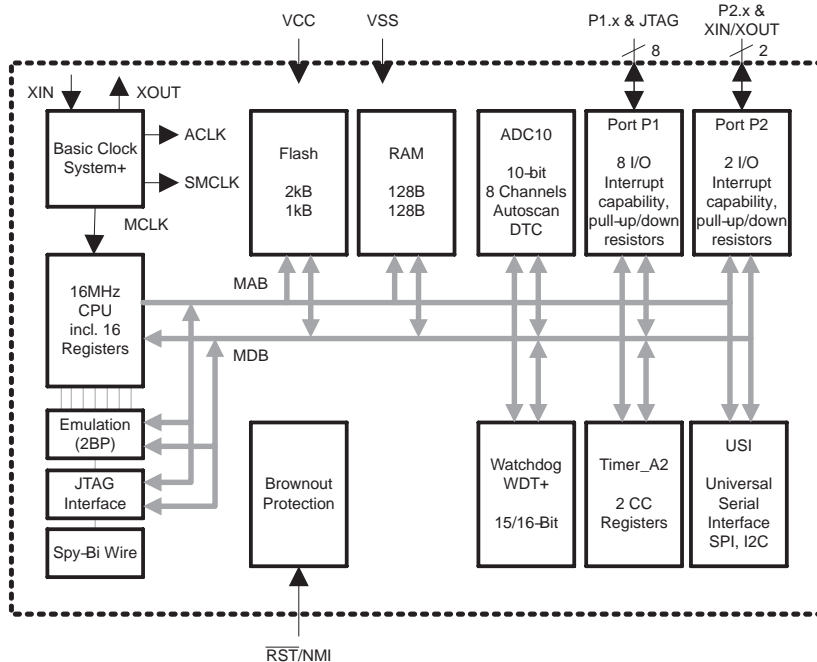

NOTE: See port schematics section for detailed I/O information.

MSP430x20x1, MSP430x20x2, MSP430x20x3 MIXED SIGNAL MICROCONTROLLER

SLAS491A – AUGUST 2005 – REVISED OCTOBER 2005

functional block diagram, MSP430x20x3

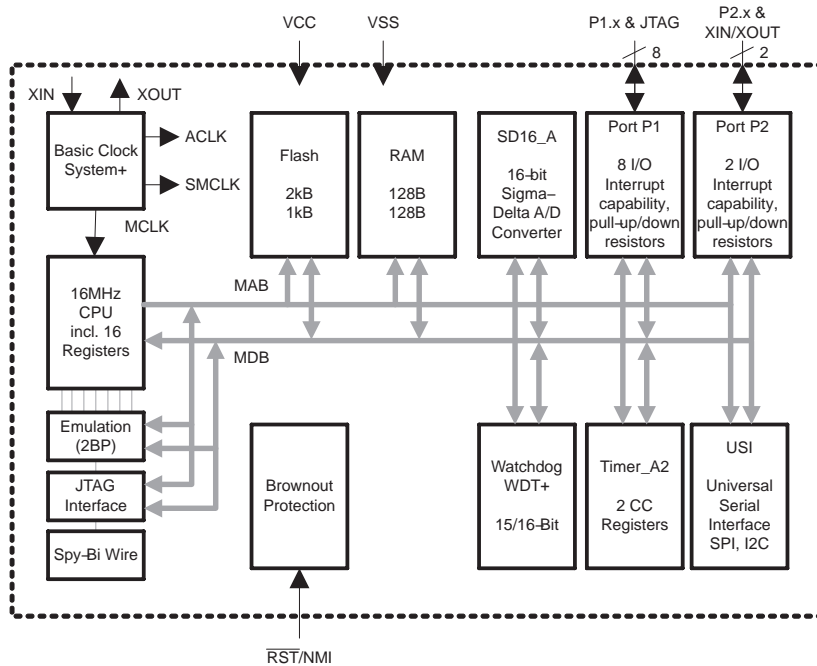

NOTE: See port schematics section for detailed I/O information.

MSP430x20x1, MSP430x20x2, MSP430x20x3 MIXED SIGNAL MICROCONTROLLER

SLAS491A – AUGUST 2005 – REVISED OCTOBER 2005

Terminal Functions, MSP430x20x1

TERMINAL				DESCRIPTION
NAME	PW, or N NO.	RSA NO.	I/O	
P1.0/TACLK/ACLK/CA0	2	1	I/O	General-purpose digital I/O pin Timer_A, clock signal TACLK input ACLK signal output Comparator_A+, CA0 input
P1.1/TA0/CA1	3	2	I/O	General-purpose digital I/O pin Timer_A, capture: CCI0A input, compare: Out0 output Comparator_A+, CA1 input
P1.2/TA1/CA2	4	3	I/O	General-purpose digital I/O pin Timer_A, capture: CCI1A input, compare: Out1 output Comparator_A+, CA2 input
P1.3/CAOUT/CA3	5	4	I/O	General-purpose digital I/O pin Comparator_A+, output / CA3 input
P1.4/SMCLK/C4/TCK	6	5	I/O	General-purpose digital I/O pin SMCLK signal output Comparator_A+, CA4 input JTAG test clock, input terminal for device programming and test
P1.5/TA0/CA5/TMS	7	6	I/O	General-purpose digital I/O pin Timer_A, compare: Out0 output Comparator_A+, CA5 input JTAG test mode select, input terminal for device programming and test
P1.6/TA1/CA6/TDI/TCLK	8	7	I/O	General-purpose digital I/O pin Timer_A, compare: Out1 output Comparator_A+, CA6 input JTAG test data input or test clock input during programming and test
P1.7/CAOUT/CA7/TDO/TDI†	9	8	I/O	General-purpose digital I/O pin Comparator_A+, output / CA7 input JTAG test data output terminal or test data input during programming and test
XIN/P2.6/TA1	13	12	I/O	Input terminal of crystal oscillator General-purpose digital I/O pin Timer_A, compare: Out1 output
XOUT/P2.7	12	11	I/O	Output terminal of crystal oscillator General-purpose digital I/O pin
RST/NMI/SBWDIO	10	9	I	Reset or nonmaskable interrupt input Spy-Bi-Wire test data input/output during programming and test
TEST/SBWTCK	11	10	I	Selects test mode for JTAG pins on Port1. The device protection fuse is connected to TEST. Spy-Bi-Wire test clock input during programming and test
VCC	1	16		Supply voltage
VSS	14	14		Ground reference
NC	NA	13, 15		Not connected
QFN Pad	NA	Package Pad	NA	QFN package pad connection to VSS recommended.

† TDO or TDI is selected via JTAG instruction.

NOTE: If XOUT/P2.7 is used as an input, excess current will flow until P2SEL.7 is cleared. This is due to the oscillator output driver connection to this pad after reset.



MSP430x20x1, MSP430x20x2, MSP430x20x3 MIXED SIGNAL MICROCONTROLLER

SLAS491A – AUGUST 2005 – REVISED OCTOBER 2005

Terminal Functions, MSP430x20x2

TERMINAL				DESCRIPTION
NAME	PW, or N NO.	RSA NO.	I/O	
P1.0/TACLK/ACLK/A0	2	1	I/O	General-purpose digital I/O pin Timer_A, clock signal TACLK input ACLK signal output ADC10 analog input A0
P1.1/TA0/A1	3	2	I/O	General-purpose digital I/O pin Timer_A, capture: CCI0A input, compare: Out0 output ADC10 analog input A1
P1.2/TA1/A2	4	3	I/O	General-purpose digital I/O pin Timer_A, capture: CCI1A input, compare: Out1 output ADC10 analog input A2
P1.3/ADC10CLK/ A3/VREF–/VeREF–	5	4	I/O	General-purpose digital I/O pin ADC10 conversion clock output ADC10 analog input A3 Input for negative external reference voltage/negative internal reference voltage output
P1.4/SMCLK/A4/VREF+/VeREF+/ TCK	6	5	I/O	General-purpose digital I/O pin SMCLK signal output ADC10 analog input A4 Input for positive external reference voltage/positive internal reference voltage output JTAG test clock, input terminal for device programming and test
P1.5/TA0/A5/SCLK/TMS	7	6	I/O	General-purpose digital I/O pin Timer_A, compare: Out0 output ADC10 analog input A5 USI: external clock input in SPI or I2C mode; clock output in SPI mode JTAG test mode select, input terminal for device programming and test
P1.6/TA1/A6/SDO/SCL/TDI/TCLK	8	7	I/O	General-purpose digital I/O pin Timer_A, capture: CCI1B input, compare: Out1 output ADC10 analog input A6 USI: Data output in SPI mode; I2C clock in I2C mode JTAG test data input or test clock input during programming and test
P1.7/A7/SDI/SDA/TDO/TDI†	9	8	I/O	General-purpose digital I/O pin ADC10 analog input A7 USI: Data input in SPI mode; I2C data in I2C mode JTAG test data output terminal or test data input during programming and test
XIN/P2.6/TA1	13	12	I/O	Input terminal of crystal oscillator General-purpose digital I/O pin Timer_A, compare: Out1 output
XOUT/P2.7	12	11	I/O	Output terminal of crystal oscillator General-purpose digital I/O pin
RST/NMI/SBWDIO	10	9	I	Reset or nonmaskable interrupt input Spy-Bi-Wire test data input/output during programming and test
TEST/SBWTCK	11	10	I	Selects test mode for JTAG pins on Port1. The device protection fuse is connected to TEST. Spy-Bi-Wire test clock input during programming and test
VCC	1	NA		Supply voltage
VSS	14	NA		Ground reference



MSP430x20x1, MSP430x20x2, MSP430x20x3 MIXED SIGNAL MICROCONTROLLER

SLAS491A – AUGUST 2005 – REVISED OCTOBER 2005

Terminal Functions, MSP430x20x2 (Continued)

TERMINAL				DESCRIPTION
NAME	PW, or N NO.	RSA NO.	I/O	
DV _{CC}	NA	16		Digital supply voltage
AV _{CC}	NA	15		Analog supply voltage
DV _{SS}	NA	14		Digital ground reference
AV _{SS}	NA	13		Analog ground reference
QFN Pad	NA	Package Pad	NA	QFN package pad connection to V _{SS} recommended.

† TDO or TDI is selected via JTAG instruction.

NOTE: If XOUT/P2.7 is used as an input, excess current will flow until P2SEL.7 is cleared. This is due to the oscillator output driver connection to this pad after reset.

Terminal Functions, MSP430x20x3

TERMINAL				DESCRIPTION
NAME	PW, or N NO.	RSA NO.	I/O	
P1.0/TACLK/ACLK/A0+	2	1	I/O	General-purpose digital I/O pin Timer_A, clock signal TACLK input ACLK signal output SD16_A positive analog input A0
P1.1/TA0/A0-/A4+	3	2	I/O	General-purpose digital I/O pin Timer_A, capture: CCI0A input, compare: Out0 output SD16_A negative analog input A0 SD16_A positive analog input A4
P1.2/TA1/A1+/A4-	4	3	I/O	General-purpose digital I/O pin Timer_A, capture: CCI1A input, compare: Out1 output SD16_A positive analog input A1 SD16_A negative analog input A4
P1.3/VREF/A1-	5	4	I/O	General-purpose digital I/O pin Input for an external reference voltage/internal reference voltage output (can be used as mid-voltage) SD16_A negative analog input A1
P1.4/SMCLK/A2+/TCK	6	5	I/O	General-purpose digital I/O pin SMCLK signal output SD16_A positive analog input A2 JTAG test clock, input terminal for device programming and test
P1.5/TA0/A2-/SCLK/TMS	7	6	I/O	General-purpose digital I/O pin Timer_A, compare: Out0 output SD16_A negative analog input A2 USI: external clock input in SPI or I2C mode; clock output in SPI mode JTAG test mode select, input terminal for device programming and test
P1.6/TA1/A3+/SDO/SCL/TDI/TCLK	8	7	I/O	General-purpose digital I/O pin Timer_A, capture: CCI1B input, compare: Out1 output SD16_A positive analog input A3 USI: Data output in SPI mode; I2C clock in I2C mode JTAG test data input or test clock input during programming and test
P1.7/A3-/SDI/SDA/TDO/TDI†	9	8	I/O	General-purpose digital I/O pin SD16_A negative analog input A3 USI: Data input in SPI mode; I2C data in I2C mode JTAG test data output terminal or test data input during programming and test



MSP430x20x1, MSP430x20x2, MSP430x20x3 MIXED SIGNAL MICROCONTROLLER

SLAS491A – AUGUST 2005 – REVISED OCTOBER 2005

Terminal Functions, MSP430x20x3 (Continued)

TERMINAL				DESCRIPTION
NAME	PW, or N NO.	RSA NO.	I/O	
XIN/P2.6/TA1	13	12	I/O	Input terminal of crystal oscillator General-purpose digital I/O pin Timer_A, compare: Out1 output
XOUT/P2.7	12	11	I/O	Output terminal of crystal oscillator General-purpose digital I/O pin
RST/NMI/SBWTIO	10	9	I	Reset or nonmaskable interrupt input Spy-Bi-Wire test data input/output during programming and test
TEST/SBWTCK	11	10	I	Selects test mode for JTAG pins on Port1. The device protection fuse is connected to TEST. Spy-Bi-Wire test clock input during programming and test
VCC	1	NA		Supply voltage
VSS	14	NA		Ground reference
DVCC	NA	16		Digital supply voltage
AVCC	NA	15		Analog supply voltage
DVSS	NA	14		Digital ground reference
AVSS	NA	13		Analog ground reference
QFN Pad	NA	Package Pad	NA	QFN package pad connection to VSS recommended.

† TDO or TDI is selected via JTAG instruction.

NOTE: If XOUT/P2.7 is used as an input, excess current will flow until P2SEL.7 is cleared. This is due to the oscillator output driver connection to this pad after reset.

short-form description

CPU

The MSP430 CPU has a 16-bit RISC architecture that is highly transparent to the application. All operations, other than program-flow instructions, are performed as register operations in conjunction with seven addressing modes for source operand and four addressing modes for destination operand.

The CPU is integrated with 16 registers that provide reduced instruction execution time. The register-to-register operation execution time is one cycle of the CPU clock.

Four of the registers, R0 to R3, are dedicated as program counter, stack pointer, status register, and constant generator respectively. The remaining registers are general-purpose registers.

Peripherals are connected to the CPU using data, address, and control buses, and can be handled with all instructions.

Program Counter	PC/R0
Stack Pointer	SP/R1
Status Register	SR/CG1/R2
Constant Generator	CG2/R3
General-Purpose Register	R4
General-Purpose Register	R5
General-Purpose Register	R6
General-Purpose Register	R7
General-Purpose Register	R8
General-Purpose Register	R9
General-Purpose Register	R10
General-Purpose Register	R11
General-Purpose Register	R12
General-Purpose Register	R13
General-Purpose Register	R14
General-Purpose Register	R15

instruction set

The instruction set consists of 51 instructions with three formats and seven address modes. Each instruction can operate on word and byte data. Table 1 shows examples of the three types of instruction formats; the address modes are listed in Table 2.

Table 1. Instruction Word Formats

Dual operands, source-destination	e.g. ADD R4,R5	R4 + R5 ----> R5
Single operands, destination only	e.g. CALL R8	PC ---->(TOS), R8----> PC
Relative jump, un/conditional	e.g. JNE	Jump-on-equal bit = 0

Table 2. Address Mode Descriptions

ADDRESS MODE	S	D	SYNTAX	EXAMPLE	OPERATION
Register	●	●	MOV Rs,Rd	MOV R10,R11	R10 ----> R11
Indexed	●	●	MOV X(Rn),Y(Rm)	MOV 2(R5),6(R6)	M(2+R5)----> M(6+R6)
Symbolic (PC relative)	●	●	MOV EDE,TONI		M(EDE) ----> M(TONI)
Absolute	●	●	MOV &MEM,&TCDAT		M(MEM) ----> M(TCDAT)
Indirect	●		MOV @Rn,Y(Rm)	MOV @R10,Tab(R6)	M(R10) ----> M(Tab+R6)
Indirect autoincrement	●		MOV @Rn+,Rm	MOV @R10+,R11	M(R10) ----> R11 R10 + 2----> R10
Immediate	●		MOV #X,TONI	MOV #45,TONI	#45 ----> M(TONI)

NOTE: S = source D = destination

MSP430x20x1, MSP430x20x2, MSP430x20x3 MIXED SIGNAL MICROCONTROLLER

SLAS491A – AUGUST 2005 – REVISED OCTOBER 2005

operating modes

The MSP430 has one active mode and five software selectable low-power modes of operation. An interrupt event can wake up the device from any of the five low-power modes, service the request and restore back to the low-power mode on return from the interrupt program.

The following six operating modes can be configured by software:

- Active mode AM;
 - All clocks are active
- Low-power mode 0 (LPM0);
 - CPU is disabled
ACLK and SMCLK remain active. MCLK is disabled
- Low-power mode 1 (LPM1);
 - CPU is disabled
ACLK and SMCLK remain active. MCLK is disabled
DCO's dc-generator is disabled if DCO not used in active mode
- Low-power mode 2 (LPM2);
 - CPU is disabled
MCLK and SMCLK are disabled
DCO's dc-generator remains enabled
ACLK remains active
- Low-power mode 3 (LPM3);
 - CPU is disabled
MCLK and SMCLK are disabled
DCO's dc-generator is disabled
ACLK remains active
- Low-power mode 4 (LPM4);
 - CPU is disabled
ACLK is disabled
MCLK and SMCLK are disabled
DCO's dc-generator is disabled
Crystal oscillator is stopped



POST OFFICE BOX 655303 • DALLAS, TEXAS 75265

MSP430x20x1, MSP430x20x2, MSP430x20x3 MIXED SIGNAL MICROCONTROLLER

SLAS491A – AUGUST 2005 – REVISED OCTOBER 2005

interrupt vector addresses

The interrupt vectors and the power-up starting address are located in the address range of 0FFFFh–0FFC0h. The vector contains the 16-bit address of the appropriate interrupt handler instruction sequence.

If the reset vector (located at address 0FFFEh) contains 0FFFFh (e.g. flash is not programmed) the CPU will go into LPM4 immediately after power-up.

INTERRUPT SOURCE	INTERRUPT FLAG	SYSTEM INTERRUPT	WORD ADDRESS	PRIORITY
Power-up External reset Watchdog Timer+ Flash key violation PC out-of-range (see Note 1)	PORIFG RSTIFG WDTIFG KEYV (see Note 2)	Reset	0FFFEh	31, highest
NMI Oscillator fault Flash memory access violation	NMIIFG OFIFG ACCVIFG (see Notes 2 & 4)	(non)-maskable, (non)-maskable, (non)-maskable	0FFFCh	30
			0FFFAh	29
			0FFF8h	28
Comparator_A+ (MSP430x20x1 only)	CAIFG (see Note 3)	maskable	0FFF6h	27
Watchdog Timer+	WDTIFG	maskable	0FFF4h	26
Timer_A2	TACCR0 CCIFG (see Note 3)	maskable	0FFF2h	25
Timer_A2	TACCR1 CCIFG. TAIFG (see Notes 2 & 3)	maskable	0FFF0h	24
			0FFEEh	23
			0FFECCh	22
ADC10 (MSP430x20x2 only)	ADC10IFG (see Note 3)	maskable		
SD16_A (MSP430x20x3 only)	SD16CCTL0 SD16OVIFG, SD16CCTL0 SD16IFG (see Notes 2 & 3)	maskable	0FFEAh	21
USI (MSP430x20x2, MSP430x20x3 only)	USIIFG, USISTTIFG (see Notes 2 & 3)	maskable	0FFE8h	20
I/O Port P2 (two flags)	P2IFG.6 to P2IFG.7 (see Notes 2 & 3)	maskable	0FFE6h	19
I/O Port P1 (eight flags)	P1IFG.0 to P1IFG.7 (see Notes 2 & 3)	maskable	0FFE4h	18
			0FFE2h	17
			0FFE0h	16
(see Note 5)			0FFDEh ... 0FFC0h	15 ... 0, lowest

- NOTES: 1. A reset is generated if the CPU tries to fetch instructions from within the module register memory address range (0h–01FFh).
 2. Multiple source flags
 3. Interrupt flags are located in the module
 4. (non)-maskable: the individual interrupt-enable bit can disable an interrupt event, but the general interrupt enable cannot.
 5. The interrupt vectors at addresses 0FFDEh to 0FFC0h are not used in this device and can be used for regular program code if necessary.



MSP430x20x1, MSP430x20x2, MSP430x20x3 MIXED SIGNAL MICROCONTROLLER

SLAS491A – AUGUST 2005 – REVISED OCTOBER 2005

special function registers

Most interrupt and module enable bits are collected into the lowest address space. Special function register bits not allocated to a functional purpose are not physically present in the device. Simple software access is provided with this arrangement.

interrupt enable 1 and 2

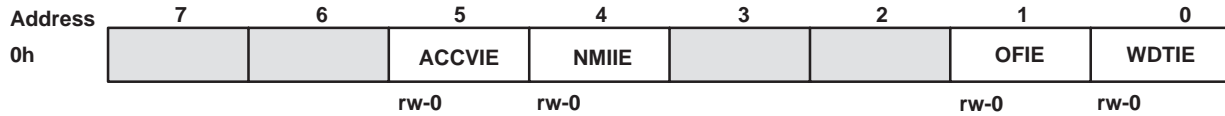

- WDTIE: Watchdog Timer interrupt enable. Inactive if watchdog mode is selected. Active if Watchdog Timer is configured in interval timer mode.
- OFIE: Oscillator fault enable
- NMIIE: (Non)maskable interrupt enable
- ACCVIE: Flash access violation interrupt enable

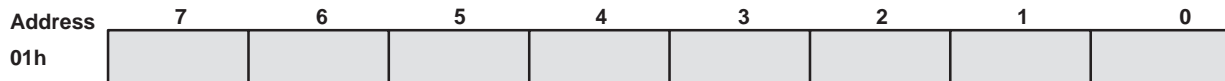

interrupt flag register 1 and 2

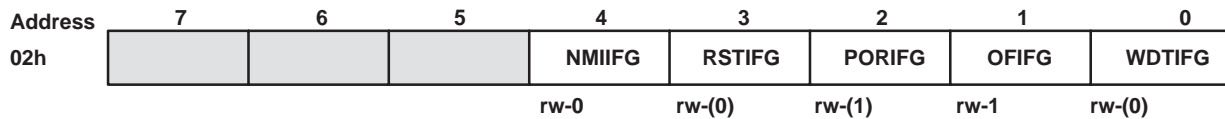

- WDTIFG: Set on Watchdog Timer overflow (in watchdog mode) or security key violation. Reset on V_{CC} power-up or a reset condition at \overline{RST}/NMI pin in reset mode.
- OFIFG: Flag set on oscillator fault
- RSTIFG: External reset interrupt flag. Set on a reset condition at \overline{RST}/NMI pin in reset mode. Reset on V_{CC} power-up
- PORIFG: Power-On Reset interrupt flag. Set on V_{CC} power-up.
- NMIIFG: Set via \overline{RST}/NMI -pin

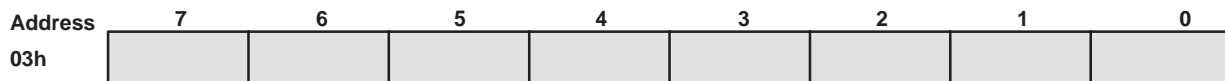

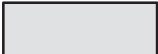
- Legend**
- rw: Bit can be read and written.
 - rw-0,1: Bit can be read and written. It is Reset or Set by PUC.
 - rw-(0,1): Bit can be read and written. It is Reset or Set by POR.
 -  SFR bit is not present in device



memory organization

		MSP430F200x	MSP430F201x
Memory Main: interrupt vector Main: code memory	Size	1KB Flash	2KB Flash
	Flash	0FFFFh–0FFC0h 0FFFFh–0FC00h	0FFFFh–0FFC0h 0FFFFh–0F800h
Information memory	Size	256 Byte	256 Byte
	Flash	010FFh – 01000h	010FFh – 01000h
RAM	Size	128 Byte 027Fh – 0200h	128 Byte 027Fh – 0200h
Peripherals	16-bit	01FFh – 0100h	01FFh – 0100h
	8-bit	0FFh – 010h	0FFh – 010h
	8-bit SFR	0Fh – 00h	0Fh – 00h

flash memory

The flash memory can be programmed via the Spy-Bi-Wire/JTAG port, or in-system by the CPU. The CPU can perform single-byte and single-word writes to the flash memory. Features of the flash memory include:

- Flash memory has n segments of main memory and four segments of information memory (A to D) of 64 bytes each. Each segment in main memory is 512 bytes in size.
- Segments 0 to n may be erased in one step, or each segment may be individually erased.
- Segments A to D can be erased individually, or as a group with segments 0–n. Segments A to D are also called *information memory*.
- Segment A contains calibration data. After reset segment A is protected against programming and erasing. It can be unlocked but care should be taken not to erase this segment if the device-specific calibration data is required.

MSP430x20x1, MSP430x20x2, MSP430x20x3 MIXED SIGNAL MICROCONTROLLER

SLAS491A – AUGUST 2005 – REVISED OCTOBER 2005

peripherals

Peripherals are connected to the CPU through data, address, and control busses and can be handled using all instructions. For complete module descriptions, refer to the *MSP430x2xx Family User's Guide*.

oscillator and system clock

The clock system is supported by the basic clock module that includes support for a 32768-Hz watch crystal oscillator, an internal very low power, low frequency oscillator and an internal digitally-controlled oscillator (DCO). The basic clock module is designed to meet the requirements of both low system cost and low-power consumption. The internal DCO provides a fast turn-on clock source and stabilizes in less than 1 μ s. The basic clock module provides the following clock signals:

- Auxiliary clock (ACLK), sourced either from a 32768-Hz watch crystal or the internal LF oscillator.
- Main clock (MCLK), the system clock used by the CPU.
- Sub-Main clock (SMCLK), the sub-system clock used by the peripheral modules.

DCO Calibration Data (provided from factory in flash info memory segment A)			
DCO Frequency	Calibration Register	Size	Address
1 MHz	CALBC1_1MHz	byte	010FFh
	CALDCO_1MHz	byte	010FEh
8 MHz	CALBC1_8MHz	byte	010FDh
	CALDCO_8MHz	byte	010FCh
12 MHz	CALBC1_12MHz	byte	010FBh
	CALDCO_12MHz	byte	010FAh
16 MHz	CALBC1_16MHz	byte	010F9h
	CALDCO_16MHz	byte	010F8h

brownout

The brownout circuit is implemented to provide the proper internal reset signal to the device during power on and power off.

digital I/O

There is one 8-bit I/O port implemented—port P1—and two bits of I/O port P2:

- All individual I/O bits are independently programmable.
- Any combination of input, output, and interrupt condition is possible.
- Edge-selectable interrupt input capability for all the eight bits of port P1 and the two bits of port P2.
- Read/write access to port-control registers is supported by all instructions.
- Each I/O has an individually programmable pull-up/pull-down resistor.

WDT+ watchdog timer

The primary function of the watchdog timer (WDT+) module is to perform a controlled system restart after a software problem occurs. If the selected time interval expires, a system reset is generated. If the watchdog function is not needed in an application, the module can be disabled or configured as an interval timer and can generate interrupts at selected time intervals.



MSP430x20x1, MSP430x20x2, MSP430x20x3 MIXED SIGNAL MICROCONTROLLER

SLAS491A – AUGUST 2005 – REVISED OCTOBER 2005

timer_A2

Timer_A2 is a 16-bit timer/counter with two capture/compare registers. Timer_A2 can support multiple capture/compares, PWM outputs, and interval timing. Timer_A2 also has extensive interrupt capabilities. Interrupts may be generated from the counter on overflow conditions and from each of the capture/compare registers.

Timer_A2 Signal Connections (MSP43020x1 only)							
Input Pin Number		Device Input Signal	Module Input Name	Module Block	Module Output Signal	Output Pin Number	
PW, N	RSA					PW, N	RSA
2 - P1.0	1 - P1.0	TACLK	TACLK	Timer	NA		
		ACLK	ACLK				
		SMCLK	SMCLK				
2 - P1.0	1 - P1.0	$\overline{\text{TACLK}}$	INCLK				
3 - P1.1	2 - P1.1	TA0	CCI0A	CCR0	TA0	3 - P1.1	2 - P1.1
		ACLK (internal)	CCI0B			7 - P1.5	6 - P1.5
		VSS	GND				
		VCC	VCC				
4 - P1.2	3 - P1.2	TA1	CCI1A	CCR1	TA1	4 - P1.2	3 - P1.2
		CAOUT (internal)	CCI1B			8 - P1.6	7 - P1.6
		VSS	GND			13 - P2.6	12 - P2.6
		VCC	VCC				

Timer_A2 Signal Connections (MSP430F20x2, MSP430F20x3)							
Input Pin Number		Device Input Signal	Module Input Name	Module Block	Module Output Signal	Output Pin Number	
PW, N	RSA					PW, N	RSA
2 - P1.0	1 - P1.0	TACLK	TACLK	Timer	NA		
		ACLK	ACLK				
		SMCLK	SMCLK				
2 - P1.0	1 - P1.0	$\overline{\text{TACLK}}$	INCLK				
3 - P1.1	2 - P1.1	TA0	CCI0A	CCR0	TA0	3 - P1.1	2 - P1.1
7 - P1.5	6 - P1.5	ACLK (internal)	CCI0B			7 - P1.5	6 - P1.5
		VSS	GND				
		VCC	VCC				
4 - P1.2	3 - P1.2	TA1	CCI1A	CCR1	TA1	4 - P1.2	3 - P1.2
8 - P1.6	7 - P1.6	TA1	CCI1B			8 - P1.6	7 - P1.6
		VSS	GND			13 - P2.6	12 - P2.6
		VCC	VCC				

comparator_A+ (MSP430x20x1 only)

The primary function of the comparator_A+ module is to support precision slope analog-to-digital conversions, battery-voltage supervision, and monitoring of external analog signals.



MSP430x20x1, MSP430x20x2, MSP430x20x3 MIXED SIGNAL MICROCONTROLLER

SLAS491A – AUGUST 2005 – REVISED OCTOBER 2005

USI (MSP430x20x2 and MSP430x20x3 only)

The universal serial interface (USI) module is used for serial data communication and provides the basic hardware for synchronous communication protocols like SPI and I2C.

ADC10 (MSP430x20x2 only)

The ADC10 module supports fast, 10-bit analog-to-digital conversions. The module implements a 10-bit SAR core, sample select control, reference generator and data transfer controller, or DTC, for automatic conversion result handling allowing ADC samples to be converted and stored without any CPU intervention.

SD16_A (MSP430x20x3 only)

The SD16_A module supports 16-bit analog-to-digital conversions. The module implements a 16-bit sigma-delta core and reference generator. In addition to external analog inputs, an internal V_{CC} sense and temperature sensor are also available.



POST OFFICE BOX 655303 • DALLAS, TEXAS 75265

MSP430x20x1, MSP430x20x2, MSP430x20x3 MIXED SIGNAL MICROCONTROLLER

SLAS491A – AUGUST 2005 – REVISED OCTOBER 2005

peripheral file map

PERIPHERALS WITH WORD ACCESS			
ADC10 (MSP430x20x2 only)	ADC control 0	ADC10CTL0	01B0h
	ADC control 1	ADC10CTL0	01B2h
	ADC memory	ADC10MEM	01B4h
SD16_A (MSP430x20x3 only)	General Control	SD16CTL	0100h
	Channel 0 Control	SD16CCTL0	0102h
	Interrupt vector word register	SD16IV	0110h
	Channel 0 conversion memory	SD16MEM0	0112h
Timer_A	Capture/compare register	TACCR1	0174h
	Capture/compare register	TACCR0	0172h
	Timer_A register	TAR	0170h
	Capture/compare control	TACCTL1	0164h
	Capture/compare control	TACCTL0	0162h
	Timer_A control	TACTL	0160h
	Timer_A interrupt vector	TAIV	012Eh
Flash Memory	Flash control 3	FCTL3	012Ch
	Flash control 2	FCTL2	012Ah
	Flash control 1	FCTL1	0128h
Watchdog Timer+	Watchdog/timer control	WDTCTL	0120h
PERIPHERALS WITH BYTE ACCESS			
ADC10 (MSP430x20x2 only)	Analog enable	ADC10AE	04Ah
SD16_A (MSP430x20x3 only)	Channel 0 Input Control	SD16INCTL0	0B0h
	Analog Enable	SD16AE	0B7h
USI (MSP430x20x2 and MSP430x20x3 only)	USI control 0	USICTL0	078h
	USI control 1	USICTL1	079h
	USI clock control	USICKCTL	07Ah
	USI bit counter	USICNT	07Bh
	USI shift register	USISR	07Ch
Comparator_A+ (MSP430x20x1 only)	Comparator_A+ port disable	CAPD	05Bh
	Comparator_A+ control 2	CACTL2	05Ah
	Comparator_A+ control 1	CACTL1	059h
Basic Clock System+	Basic clock system control 3	BCSCTL3	053h
	Basic clock system control 2	BCSCTL2	058h
	Basic clock system control 1	BCSCTL1	057h
	DCO clock frequency control	DCOCTL	056h
Port P2	Port P2 resistor enable	P2REN	02Fh
	Port P2 selection	P2SEL	02Eh
	Port P2 interrupt enable	P2IE	02Dh
	Port P2 interrupt edge select	P2IES	02Ch
	Port P2 interrupt flag	P2IFG	02Bh
	Port P2 direction	P2DIR	02Ah
	Port P2 output	P2OUT	029h
	Port P2 input	P2IN	028h
Port P1	Port P1 resistor enable	P1REN	027h
	Port P1 selection	P1SEL	026h
	Port P1 interrupt enable	P1IE	025h
	Port P1 interrupt edge select	P1IES	024h
	Port P1 interrupt flag	P1IFG	023h
	Port P1 direction	P1DIR	022h
	Port P1 output	P1OUT	021h
	Port P1 input	P1IN	020h
Special Function	SFR interrupt flag 2	IFG2	003h
	SFR interrupt flag 1	IFG1	002h
	SFR interrupt enable 2	IE2	001h
	SFR interrupt enable 1	IE1	000h



MSP430x20x1, MSP430x20x2, MSP430x20x3 MIXED SIGNAL MICROCONTROLLER

SLAS491A – AUGUST 2005 – REVISED OCTOBER 2005

absolute maximum ratings†

Voltage applied at V_{CC} to V_{SS}	-0.3 V to 4.1 V
Voltage applied to any pin (see Note 2)	-0.3 V to $V_{CC}+0.3$ V
Diode current at any device terminal	± 2 mA
Storage temperature, T_{stg} (unprogrammed device, see Note 3)	-55°C to 150°C
Storage temperature, T_{stg} (programmed device, see Note 3)	-40°C to 85°C

- NOTES: 1. Stresses beyond those listed under “absolute maximum ratings” may cause permanent damage to the device. These are stress ratings only, and functional operation of the device at these or any other conditions beyond those indicated under “recommended operating conditions” is not implied. Exposure to absolute-maximum-rated conditions for extended periods may affect device reliability.
2. All voltages referenced to V_{SS} . The JTAG fuse-blow voltage, V_{FB} , is allowed to exceed the absolute maximum rating. The voltage is applied to the TEST pin when blowing the JTAG fuse.
3. Higher temperature may be applied during board soldering process according to the current JEDEC J-STD-020 specification with peak reflow temperatures not higher than classified on the device label on the shipping boxes or reels.

recommended operating conditions

		MIN	NOM	MAX	UNITS
Supply voltage during program execution, V_{CC}		1.8		3.6	V
Supply voltage during program/erase flash memory, V_{CC}		2.2		3.6	V
Supply voltage, V_{SS}			0		V
Operating free-air temperature range, T_A		-40		85	°C
Processor frequency f_{SYSTEM} (Maximum MCLK frequency)	$V_{CC} = 1.8$ V, Duty Cycle = 50% $\pm 10\%$	dc		6	MHz
	$V_{CC} = 2.7$ V, Duty Cycle = 50% $\pm 10\%$	dc		12	
	$V_{CC} \geq 3.3$ V, Duty Cycle = 50% $\pm 10\%$	dc		16	

- NOTES: 1. The MSP430 CPU is clocked directly with MCLK. Both the high and low phase of MCLK must not exceed the pulse width of the specified maximum frequency.
2. Modules might have a different maximum input clock specification. Refer to the specification of the respective module in this datasheet.

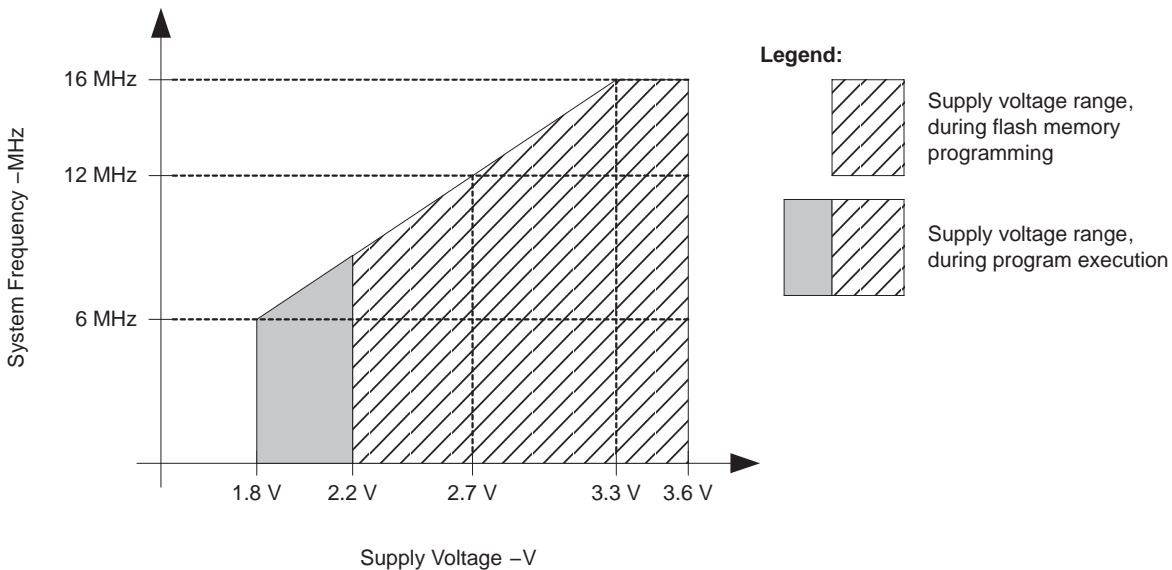

NOTE: Minimum processor frequency is defined by system clock. Flash program or erase operations require a minimum V_{CC} of 2.2 V.

Figure 1. Save Operating Area



electrical characteristics over recommended ranges of supply voltage and operating free-air temperature (unless otherwise noted)

active mode supply current (into V_{CC}) excluding external current (see Notes 1 and 2)

PARAMETER	TEST CONDITIONS	VCC	MIN	TYP	MAX	UNIT
I_{AM} , 1MHz Active mode (AM) current (1MHz)	$f_{DCO} = f_{MCLK} = f_{SMCLK} = 1\text{MHz}$, $f_{ACLK} = 32,768\text{Hz}$, Program executes in flash, BCSCTL1 = CALBC1_1MHz, DCOCTL = CALDCO_1MHz, CPUOFF = 0, SCG0 = 0, SCG1 = 0, OSCOFF = 0	2.2 V		220	270	μA
		3 V		300	370	
I_{AM} , 1MHz Active mode (AM) current (1MHz)	$f_{DCO} = f_{MCLK} = f_{SMCLK} = 1\text{MHz}$, $f_{ACLK} = 32,768\text{Hz}$, Program executes in RAM, BCSCTL1 = CALBC1_1MHz, DCOCTL = CALDCO_1MHz, CPUOFF = 0, SCG0 = 0, SCG1 = 0, OSCOFF = 0	2.2 V		190		μA
		3 V		260		
I_{AM} , 4kHz Active mode (AM) current (4kHz)	$f_{MCLK} = f_{SMCLK} = f_{ACLK} = 32,768\text{Hz}/8 = 4,096\text{Hz}$, $f_{DCO} = 0\text{Hz}$, Program executes in flash, SELMx = 11, SELS = 1, DIVMx = DIVSx = DIVAx = 11, CPUOFF = 0, SCG0 = 1, SCG1 = 0, OSCOFF = 0	2.2 V		1.2	3	μA
		3 V		1.6	4	
I_{AM} , 100kHz Active mode (AM) current (100kHz)	$f_{MCLK} = f_{SMCLK} = f_{DCO}(0, 0) \approx 100\text{kHz}$, $f_{ACLK} = 0\text{Hz}$, Program executes in flash, RSELx = 0, DCOx = 0, CPUOFF = 0, SCG0 = 0, SCG1 = 0, OSCOFF = 1	2.2 V		37	50	μA
		3 V		40	55	

- NOTES: 1. All inputs are tied to 0 V or V_{CC} . Outputs do not source or sink any current.
2. The currents are characterized with a Micro Crystal CC4V-T1A SMD crystal with a load capacitance of 9 pF. The internal and external load capacitance is chosen to closely match the required 9pF.

typical characteristics – active mode supply current (into V_{CC})

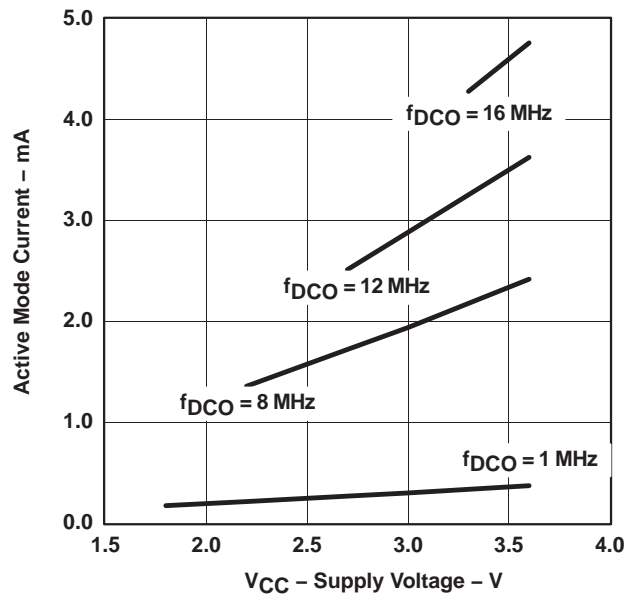

Figure 2. Active mode current vs V_{CC} , $T_A = 25^\circ\text{C}$

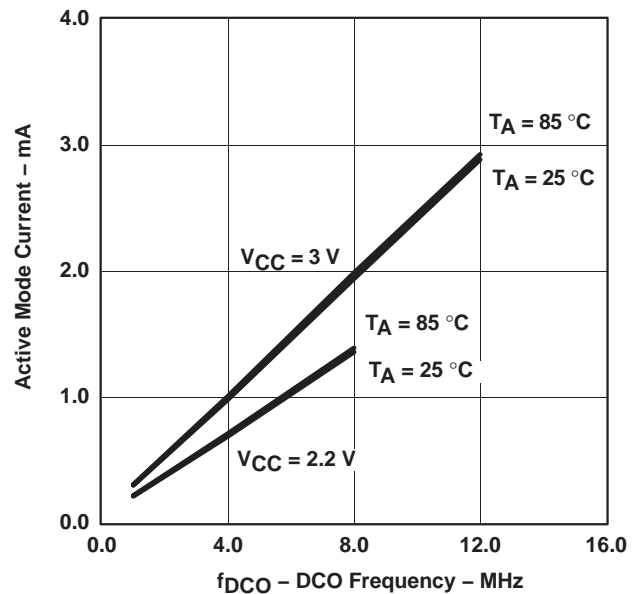

Figure 3. Active mode current vs DCO frequency

MSP430x20x1, MSP430x20x2, MSP430x20x3 MIXED SIGNAL MICROCONTROLLER

SLAS491A – AUGUST 2005 – REVISED OCTOBER 2005

electrical characteristics over recommended ranges of supply voltage and operating free-air temperature (unless otherwise noted) (continued)

low power mode supply currents (into V_{CC}) excluding external current (see Notes 1 and 2)

PARAMETER	TEST CONDITIONS	VCC	MIN	TYP	MAX	UNIT
$I_{LPM0, 1MHz}$ Low-power mode 0 (LPM0) current, see Note 3	$f_{MCLK} = 0MHz,$ $f_{SMCLK} = f_{DCO} = 1MHz,$ $f_{ACLK} = 32,768Hz,$ $BCSCTL1 = CALBC1_1MHz,$ $DCOCTL = CALDCO_1MHz,$ $CPUOFF = 1, SCG0 = 0, SCG1 = 0, OSCOFF = 0$	2.2 V		65	80	μA
		3 V		85	100	
$I_{LPM0, 100kHz}$ Low-power mode 0 (LPM0) current, see Note 3	$f_{MCLK} = 0MHz,$ $f_{SMCLK} = f_{DCO}(0, 0) \approx 100kHz,$ $f_{ACLK} = 0Hz,$ $RSELx = 0, DCOx = 0,$ $CPUOFF = 1, SCG0 = 0, SCG1 = 0, OSCOFF = 1$	2.2 V		37	48	μA
		3 V		41	52	
I_{LPM2} Low-power mode 1 (LPM2) current, see Note 4	$f_{MCLK} = f_{SMCLK} = 0MHz, f_{DCO} = 1MHz,$ $f_{ACLK} = 32,768Hz,$ $BCSCTL1 = CALBC1_1MHz,$ $DCOCTL = CALDCO_1MHz,$ $CPUOFF = 1, SCG0 = 0, SCG1 = 1, OSCOFF = 0$	2.2 V		22	29	μA
		3 V		25	32	
$I_{LPM3, LFXT1}$ Low-power mode 3 (LPM3) current, see Note 4	$f_{DCO} = f_{MCLK} = f_{SMCLK} = 0MHz,$ $f_{ACLK} = 32,768Hz,$ $CPUOFF = 1, SCG0 = 1, SCG1 = 1,$ $OSCOFF = 0$	2.2 V	$T_A = -40^\circ C$	0.7	1.2	μA
			$T_A = 25^\circ C$	0.7	1.0	
			$T_A = 85^\circ C$	1.4	2.3	
		3 V	$T_A = -40^\circ C$	0.9	1.2	
			$T_A = 25^\circ C$	0.9	1.2	
			$T_A = 85^\circ C$	1.6	2.8	
$I_{LPM3, VLO}$ Low-power mode 3 current, (LPM3) see Note 4	$f_{DCO} = f_{MCLK} = f_{SMCLK} = 0MHz,$ f_{ACLK} from internal LF oscillator (VLO), $CPUOFF = 1, SCG0 = 1, SCG1 = 1,$ $OSCOFF = 0$	2.2 V	$T_A = -40^\circ C$	0.4	0.7	μA
			$T_A = 25^\circ C$	0.5	0.7	
			$T_A = 85^\circ C$	1.0	1.6	
		3 V	$T_A = -40^\circ C$	0.5	0.9	
			$T_A = 25^\circ C$	0.6	0.9	
			$T_A = 85^\circ C$	1.3	1.8	
I_{LPM4} Low-power mode 4 (LPM4) current, see Note 5	$f_{DCO} = f_{MCLK} = f_{SMCLK} = 0MHz,$ $f_{ACLK} = 32,768Hz,$ $CPUOFF = 1, SCG0 = 1, SCG1 = 1,$ $OSCOFF = 1$	2.2 V/3 V	$T_A = -40^\circ C$	0.1	0.5	μA
			$T_A = 25^\circ C$	0.1	0.5	
			$T_A = 85^\circ C$	0.8	1.5	

- NOTES: 1. All inputs are tied to 0 V or V_{CC} . Outputs do not source or sink any current.
 2. The currents are characterized with a Micro Crystal CC4V-T1A SMD crystal with a load capacitance of 9 pF. The internal and external load capacitance is chosen to closely match the required 9pF.
 3. Current for brownout and WDT clocked by SMCLK included.
 4. Current for brownout and WDT clocked by ACLK included.
 5. Current for brownout included.

MSP430x20x1, MSP430x20x2, MSP430x20x3 MIXED SIGNAL MICROCONTROLLER

SLAS491A – AUGUST 2005 – REVISED OCTOBER 2005

electrical characteristics over recommended ranges of supply voltage and operating free-air temperature (unless otherwise noted) (continued)

Schmitt-trigger inputs – Ports P1 and P2

PARAMETER		TEST CONDITIONS	VCC	MIN	TYP	MAX	UNIT
V_{IT+}	Positive-going input threshold voltage			0.45		0.75	V_{CC}
			2.2 V	1.00		1.65	V
			3 V	1.35		2.25	
V_{IT-}	Negative-going input threshold voltage			0.25		0.55	V_{CC}
			2.2 V	0.55		1.20	V
			3 V	0.75		1.65	
V_{hys}	Input voltage hysteresis ($V_{IT+} - V_{IT-}$)		2.2 V	0.2		1.0	V
			3 V	0.3		1.0	
R_{Pull}	Pull-up/pull-down resistor	For pull-up: $V_{IN} = V_{SS}$; For pull-down: $V_{IN} = V_{CC}$		20	35	50	k Ω
C_I	Input Capacitance	$V_{IN} = V_{SS}$ or V_{CC}			5		pF

inputs – Ports P1 and P2

PARAMETER		TEST CONDITIONS	VCC	MIN	TYP	MAX	UNIT
$t_{(int)}$	External interrupt timing	Port P1, P2: P1.x to P2.x, External trigger puls width to set interrupt flag, (see Note 1)	2.2 V/3 V	20			ns

NOTES: 1. An external signal sets the interrupt flag every time the minimum interrupt puls width $t_{(int)}$ is met. It may be set even with trigger signals shorter than $t_{(int)}$.

leakage current – Ports P1 and P2

PARAMETER		TEST CONDITIONS	VCC	MIN	TYP	MAX	UNIT
$I_{lkg}(P_{x.x})$	High-impedance leakage current	see Notes 1 and 2	2.2 V/3 V			± 50	nA

NOTES: 1. The leakage current is measured with V_{SS} or V_{CC} applied to the corresponding pin(s), unless otherwise noted.
2. The leakage of the digital port pins is measured individually. The port pin is selected for input and the pull-up/pull-down resistor is disabled.

MSP430x20x1, MSP430x20x2, MSP430x20x3 MIXED SIGNAL MICROCONTROLLER

SLAS491A – AUGUST 2005 – REVISED OCTOBER 2005

electrical characteristics over recommended ranges of supply voltage and operating free-air temperature (unless otherwise noted) (continued)

outputs – Ports P1 and P2

PARAMETER	TEST CONDITIONS	VCC	MIN	TYP	MAX	UNIT
V _{OH}	High-level output voltage	2.2 V	V _{CC} -0.25		V _{CC}	V
		3 V	V _{CC} -0.25	V _{CC}		
					3 V	
V _{OL}	Low-level output voltage	2.2 V	V _{SS}			V _{SS} +0.25
					2.2 V	
		3 V	V _{SS}	V _{SS}		V _{SS} +0.25
					3 V	

- NOTES: 1. The maximum total current, I_{OHmax} and I_{OLmax}, for all outputs combined, should not exceed ±12 mA to hold the maximum voltage drop specified.
 2. The maximum total current, I_{OHmax} and I_{OLmax}, for all outputs combined, should not exceed ±48 mA to hold the maximum voltage drop specified.

output frequency – Ports P1 and P2

PARAMETER	TEST CONDITIONS	VCC	MIN	TYP	MAX	UNIT
f _{Px.y}	Port output frequency (with load) P1.4/SMCLK, C _L = 20 pF, R _L = 1 kOhm (see Note 1 and 2)	2.2 V			10	MHz
		3 V			12	MHz
f _{Port_CLK}	Clock output frequency P2.0/ACLK, P1.4/SMCLK, C _L = 20 pF (see Note 2)	2.2 V			12	MHz
		3 V			16	MHz

- NOTES: 1. A resistive divider with 2 times 0.5 kΩ between V_{CC} and V_{SS} is used as load. The output is connected to the center tap of the divider.
 2. The output voltage reaches at least 10% and 90% V_{CC} at the specified toggle frequency.



electrical characteristics over recommended ranges of supply voltage and operating free-air temperature (unless otherwise noted) (continued)

typical characteristics – outputs

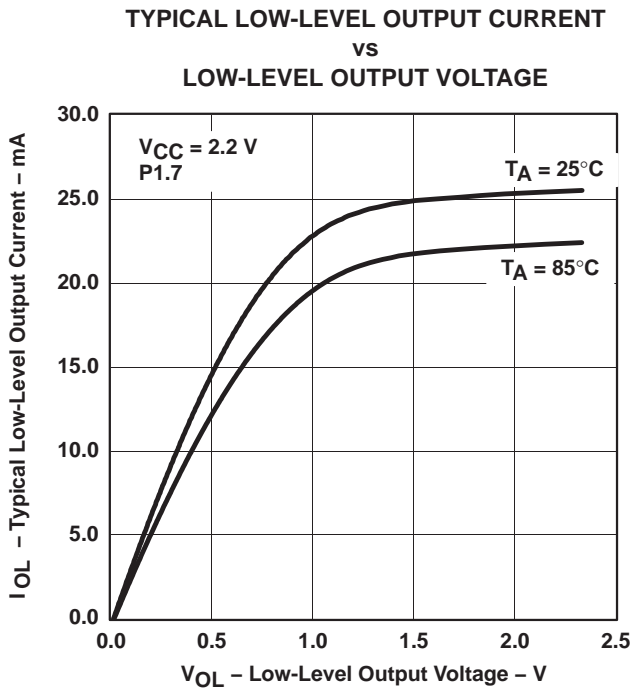

Figure 4

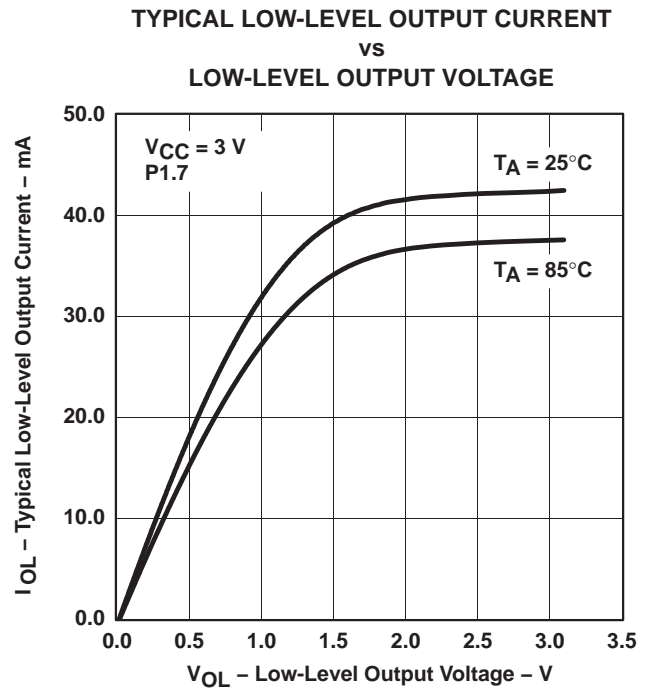

Figure 5

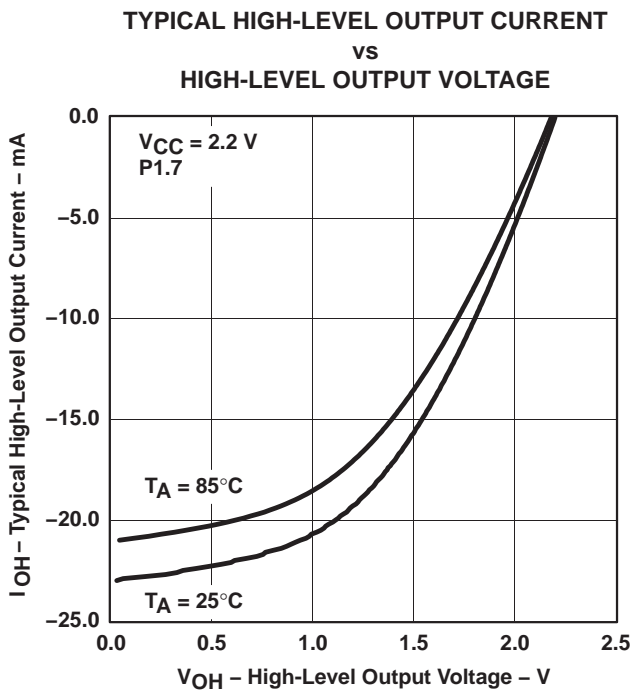

Figure 6

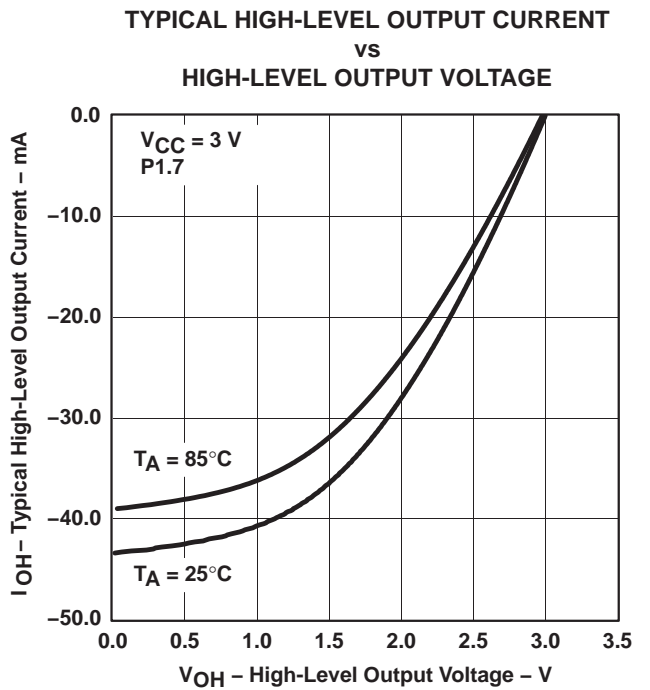

Figure 7

NOTE: One output loaded at a time.

MSP430x20x1, MSP430x20x2, MSP430x20x3 MIXED SIGNAL MICROCONTROLLER

SLAS491A – AUGUST 2005 – REVISED OCTOBER 2005

electrical characteristics over recommended ranges of supply voltage and operating free-air temperature (unless otherwise noted) (continued)

POR/brownout reset (BOR) (see Notes 1 and 2)

PARAMETER	TEST CONDITIONS	VCC	MIN	TYP	MAX	UNIT
V _{CC(start)}	(see Figure 8)	$dV_{CC}/dt \leq 3 \text{ V/s}$		$0.7 \times V_{(B_IT-)}$		V
V _(B_IT-)	(see Figure 8 through Figure 10)	$dV_{CC}/dt \leq 3 \text{ V/s}$			1.71	V
V _{hys(B_IT-)}	(see Figure 8)	$dV_{CC}/dt \leq 3 \text{ V/s}$	70	130	180	mV
t _{d(BOR)}	(see Figure 8)				2000	μs
t _(reset)	Pulse length needed at $\overline{\text{RST}}/\text{NMI}$ pin to accepted reset internally	2.2 V/3 V	2			μs

- NOTES: 1. The current consumption of the brownout module is already included in the I_{CC} current consumption data. The voltage level V_(B_IT-) + V_{hys(B_IT-)} is ≤ 1.8V.
2. During power up, the CPU begins code execution following a period of t_{d(BOR)} after V_{CC} = V_(B_IT-) + V_{hys(B_IT-)}. The default DCO settings must not be changed until V_{CC} ≥ V_{CC(min)}, where V_{CC(min)} is the minimum supply voltage for the desired operating frequency.

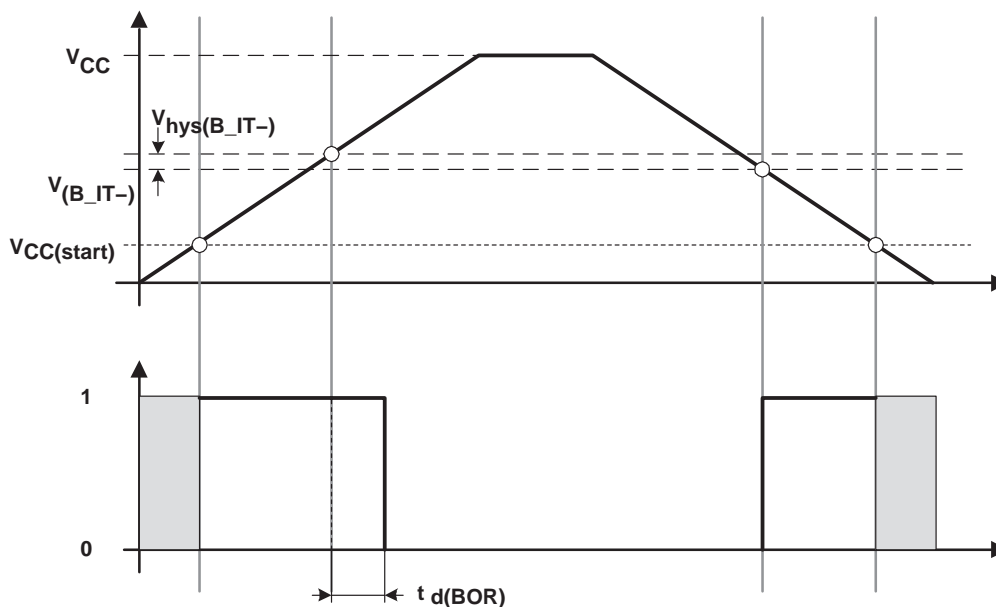

Figure 8. POR/Brownout Reset (BOR) vs Supply Voltage

electrical characteristics over recommended ranges of supply voltage and operating free-air temperature (unless otherwise noted) (continued)

typical characteristics – POR/brownout reset (BOR)

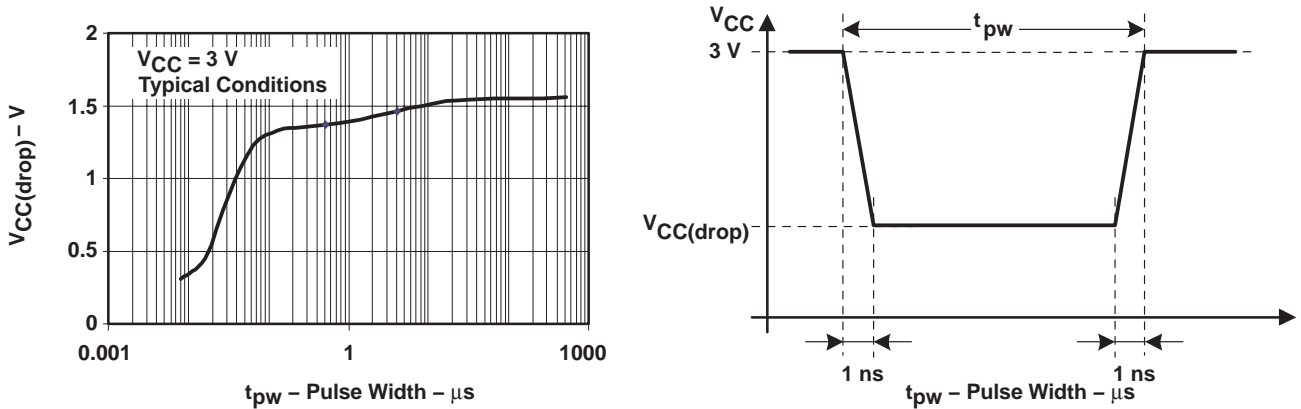

Figure 9. $V_{CC(drop)}$ Level With a Square Voltage Drop to Generate a POR/Brownout Signal

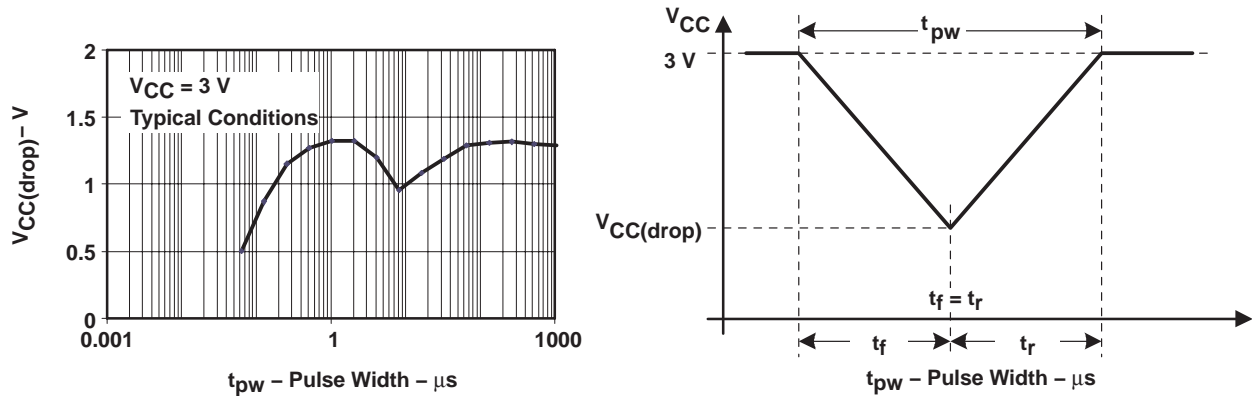

Figure 10. $V_{CC(drop)}$ Level With a Triangle Voltage Drop to Generate a POR/Brownout Signal

MSP430x20x1, MSP430x20x2, MSP430x20x3 MIXED SIGNAL MICROCONTROLLER

SLAS491A – AUGUST 2005 – REVISED OCTOBER 2005

electrical characteristics over recommended ranges of supply voltage and operating free-air temperature (unless otherwise noted) (continued)

main DCO characteristics

- All ranges selected by RSELx overlap with RSELx + 1: RSELx = 0 overlaps RSELx = 1, ... RSELx = 14 overlaps RSELx = 15.
- DCO control bits DCOx have a step size as defined by parameter S_{DCO}.
- Modulation control bits MODx select how often f_{DCO(RSEL,DCO+1)} is used within the period of 32 DCOCLK cycles. The frequency f_{DCO(RSEL,DCO)} is used for the remaining cycles. The frequency is an average equal to:

$$f_{average} = \frac{32 \times f_{DCO(RSEL,DCO)} \times f_{DCO(RSEL,DCO+1)}}{MOD \times f_{DCO(RSEL,DCO)} + (32 - MOD) \times f_{DCO(RSEL,DCO+1)}}$$

DCO frequency

PARAMETER		TEST CONDITIONS	VCC	MIN	TYP	MAX	UNIT
Vcc	Supply voltage range	RSELx < 14		1.8		3.6	V
		RSELx = 14		2.2		3.6	V
		RSELx = 15		3.0		3.6	V
f _{DCO(0,0)}	DCO frequency (0, 0)	RSELx = 0, DCOx = 0, MODx = 0	2.2 V/3 V	0.06		0.14	MHz
f _{DCO(0,3)}	DCO frequency (0, 3)	RSELx = 0, DCOx = 3, MODx = 0	2.2 V/3 V	0.07		0.17	MHz
f _{DCO(1,3)}	DCO frequency (1, 3)	RSELx = 1, DCOx = 3, MODx = 0	2.2 V/3 V	0.10		0.20	MHz
f _{DCO(2,3)}	DCO frequency (2, 3)	RSELx = 2, DCOx = 3, MODx = 0	2.2 V/3 V	0.14		0.28	MHz
f _{DCO(3,3)}	DCO frequency (3, 3)	RSELx = 3, DCOx = 3, MODx = 0	2.2 V/3 V	0.20		0.40	MHz
f _{DCO(4,3)}	DCO frequency (4, 3)	RSELx = 4, DCOx = 3, MODx = 0	2.2 V/3 V	0.28		0.54	MHz
f _{DCO(5,3)}	DCO frequency (5, 3)	RSELx = 5, DCOx = 3, MODx = 0	2.2 V/3 V	0.39		0.77	MHz
f _{DCO(6,3)}	DCO frequency (6, 3)	RSELx = 6, DCOx = 3, MODx = 0	2.2 V/3 V	0.54		1.06	MHz
f _{DCO(7,3)}	DCO frequency (7, 3)	RSELx = 7, DCOx = 3, MODx = 0	2.2 V/3 V	0.80		1.50	MHz
f _{DCO(8,3)}	DCO frequency (8, 3)	RSELx = 8, DCOx = 3, MODx = 0	2.2 V/3 V	1.10		2.10	MHz
f _{DCO(9,3)}	DCO frequency (9, 3)	RSELx = 9, DCOx = 3, MODx = 0	2.2 V/3 V	1.60		3.00	MHz
f _{DCO(10,3)}	DCO frequency (10, 3)	RSELx = 10, DCOx = 3, MODx = 0	2.2 V/3 V	2.50		4.30	MHz
f _{DCO(11,3)}	DCO frequency (11, 3)	RSELx = 11, DCOx = 3, MODx = 0	2.2 V/3 V	3.00		5.50	MHz
f _{DCO(12,3)}	DCO frequency (12, 3)	RSELx = 12, DCOx = 3, MODx = 0	2.2 V/3 V	4.30		7.30	MHz
f _{DCO(13,3)}	DCO frequency (13, 3)	RSELx = 13, DCOx = 3, MODx = 0	2.2 V/3 V	6.00		9.60	MHz
f _{DCO(14,3)}	DCO frequency (14, 3)	RSELx = 14, DCOx = 3, MODx = 0	2.2 V/3 V	8.60		13.9	MHz
f _{DCO(15,3)}	DCO frequency (15, 3)	RSELx = 15, DCOx = 3, MODx = 0	3 V	12.0		18.5	MHz
f _{DCO(15,7)}	DCO frequency (15, 7)	RSELx = 15, DCOx = 7, MODx = 0	3 V	16.0		26.0	MHz
S _{RSEL}	Frequency step between range RSEL and RSEL+1	S _{RSEL} = f _{DCO(RSEL+1,DCO)} /f _{DCO(RSEL,DCO)}	2.2 V/3 V			1.55	ratio
S _{DCO}	Frequency step between tap DCO and DCO+1	S _{DCO} = f _{DCO(RSEL,DCO+1)} /f _{DCO(RSEL,DCO)}	2.2 V/3 V	1.05	1.08	1.12	
Duty Cycle		Measured at P1.4/SMCLK	2.2 V/3 V	40	50	60	%



MSP430x20x1, MSP430x20x2, MSP430x20x3 MIXED SIGNAL MICROCONTROLLER

SLAS491A – AUGUST 2005 – REVISED OCTOBER 2005

electrical characteristics over recommended ranges of supply voltage and operating free-air temperature (unless otherwise noted) (continued)

calibrated DCO frequencies – tolerance at calibration

PARAMETER	TEST CONDITIONS	T _A	VCC	MIN	TYP	MAX	UNIT
Frequency tolerance at calibration		25°C	3 V	-1	±0.2	+1	%
f _{CAL(1MHz)} 1MHz calibration value	BCSCTL1= CALBC1_1MHz; DCOCTL = CALDCO_1MHz Gating time: 5ms	25°C	3 V	0.990	1	1.010	MHz
f _{CAL(8MHz)} 8MHz calibration value	BCSCTL1= CALBC1_8MHz; DCOCTL = CALDCO_8MHz Gating time: 5ms	25°C	3 V	7.920	8	8.080	MHz
f _{CAL(12MHz)} 12MHz calibration value	BCSCTL1= CALBC1_12MHz; DCOCTL = CALDCO_12MHz Gating time: 5ms	25°C	3 V	11.88	12	12.12	MHz
f _{CAL(16MHz)} 16MHz calibration value	BCSCTL1= CALBC1_16MHz; DCOCTL = CALDCO_16MHz Gating time: 2ms	25°C	3 V	15.84	16	16.16	MHz

calibrated DCO frequencies – tolerance over temperature 0°C – +85°C

PARAMETER	TEST CONDITIONS	T _A	VCC	MIN	TYP	MAX	UNIT
1 MHz tolerance over temperature		0°C – +85°C	3.0 V	-2.5	±0.5	+2.5	%
8 MHz tolerance over temperature		0°C – +85°C	3.0 V	-2.5	±1.0	+2.5	%
12 MHz tolerance over temperature		0°C – +85°C	3.0 V	-2.5	±1.0	+2.5	%
16 MHz tolerance over temperature		0°C – +85°C	3.0 V	-3.0	±2.0	+3.0	%
f _{CAL(1MHz)} 1MHz calibration value	BCSCTL1= CALBC1_1MHz; DCOCTL = CALDCO_1MHz Gating time: 5ms	0°C – +85°C	2.2 V	0.970	1	1.030	MHz
			3.0 V	0.975	1	1.025	MHz
			3.6 V	0.970	1	1.030	MHz
f _{CAL(8MHz)} 8MHz calibration value	BCSCTL1= CALBC1_8MHz; DCOCTL = CALDCO_8MHz Gating time: 5ms	0°C – +85°C	2.2 V	7.760	8	8.400	MHz
			3.0 V	7.800	8	8.200	MHz
			3.6 V	7.600	8	8.240	MHz
f _{CAL(12MHz)} 12MHz calibration value	BCSCTL1= CALBC1_12MHz; DCOCTL = CALDCO_12MHz Gating time: 5ms	0°C – +85°C	2.2 V	11.70	12	12.30	MHz
			3.0 V	11.70	12	12.30	MHz
			3.6 V	11.70	12	12.30	MHz
f _{CAL(16MHz)} 16MHz calibration value	BCSCTL1= CALBC1_16MHz; DCOCTL = CALDCO_16MHz Gating time: 2ms	0°C – +85°C	3.0 V	15.52	16	16.48	MHz
			3.6 V	15.00	16	16.48	MHz



MSP430x20x1, MSP430x20x2, MSP430x20x3 MIXED SIGNAL MICROCONTROLLER

SLAS491A – AUGUST 2005 – REVISED OCTOBER 2005

electrical characteristics over recommended ranges of supply voltage and operating free-air temperature (unless otherwise noted) (continued)

calibrated DCO frequencies – tolerance over supply voltage V_{CC}

PARAMETER	TEST CONDITIONS	T_A	V_{CC}	MIN	TYP	MAX	UNIT
1 MHz tolerance over V_{CC}		25°C	1.8 V – 3.6 V	-2.5	±2	+2.5	%
8 MHz tolerance over V_{CC}		25°C	1.8 V – 3.6 V	-2.5	±2	+2.5	%
12 MHz tolerance over V_{CC}		25°C	2.2 V – 3.6 V	-2.5	±2	+2.5	%
16 MHz tolerance over V_{CC}		25°C	3.0 V – 3.6 V	-3	±2	+3	%
$f_{CAL}(1MHz)$ 1MHz calibration value	BCSCTL1= CALBC1_1MHz; DCOCTL = CALDCO_1MHz Gating time: 5ms	25°C	1.8 V – 3.6 V	0.970	1	1.030	MHz
$f_{CAL}(8MHz)$ 8MHz calibration value	BCSCTL1= CALBC1_8MHz; DCOCTL = CALDCO_8MHz Gating time: 5ms	25°C	1.8 V – 3.6 V	7.760	8	8.240	MHz
$f_{CAL}(12MHz)$ 12MHz calibration value	BCSCTL1= CALBC1_12MHz; DCOCTL = CALDCO_12MHz Gating time: 5ms	25°C	2.2 V – 3.6 V	11.64	12	12.36	MHz
$f_{CAL}(16MHz)$ 16MHz calibration value	BCSCTL1= CALBC1_16MHz; DCOCTL = CALDCO_16MHz Gating time: 2ms	25°C	3.0 V – 3.6 V	15.00	16	16.48	MHz

calibrated DCO frequencies – overall tolerance

PARAMETER	TEST CONDITIONS	T_A	V_{CC}	MIN	TYP	MAX	UNIT
1 MHz tolerance overall		-40°C – +85°C	1.8 V – 3.6 V	-5	±2	+5	%
8 MHz tolerance overall		-40°C – +85°C	1.8 V – 3.6 V	-5	±2	+5	%
12 MHz tolerance overall		-40°C – +85°C	2.2 V – 3.6 V	-5	±2	+5	%
16 MHz tolerance overall		-40°C – +85°C	3.0 V – 3.6 V	-6	±3	+6	%
$f_{CAL}(1MHz)$ 1MHz calibration value	BCSCTL1= CALBC1_1MHz; DCOCTL = CALDCO_1MHz Gating time: 5ms	-40°C – +85°C	1.8 V – 3.6 V	0.950	1	1.050	MHz
$f_{CAL}(8MHz)$ 8MHz calibration value	BCSCTL1= CALBC1_8MHz; DCOCTL = CALDCO_8MHz Gating time: 5ms	-40°C – +85°C	1.8 V – 3.6 V	7.600	8	8.400	MHz
$f_{CAL}(12MHz)$ 12MHz calibration value	BCSCTL1= CALBC1_12MHz; DCOCTL = CALDCO_12MHz Gating time: 5ms	-40°C – +85°C	2.2 V – 3.6 V	11.40	12	12.60	MHz
$f_{CAL}(16MHz)$ 16MHz calibration value	BCSCTL1= CALBC1_16MHz; DCOCTL = CALDCO_16MHz Gating time: 2ms	-40°C – +85°C	3.0 V – 3.6 V	15.00	16	17.00	MHz



electrical characteristics over recommended ranges of supply voltage and operating free-air temperature (unless otherwise noted) (continued)

typical characteristics – calibrated 1MHz DCO frequency

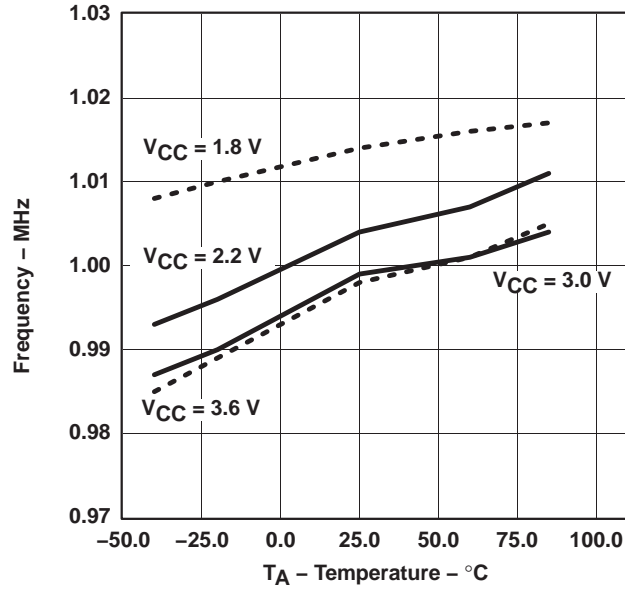

Figure 11. Calibrated 1 MHz Frequency vs. Temperature

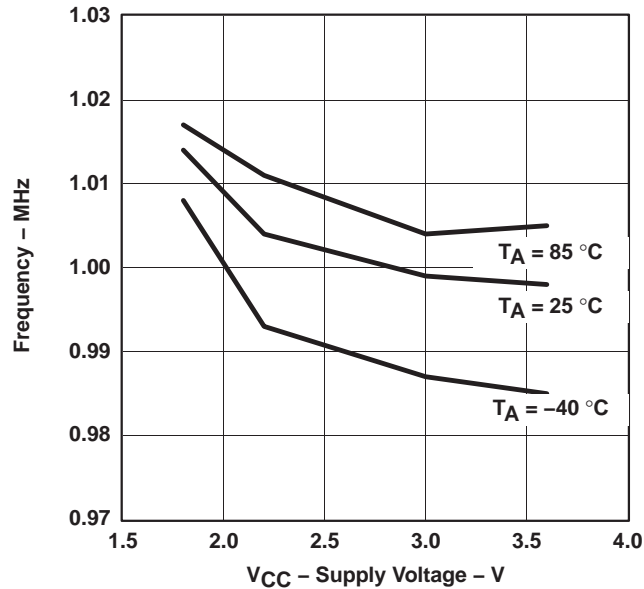

Figure 12. Calibrated 1 MHz Frequency vs. V_{CC}

MSP430x20x1, MSP430x20x2, MSP430x20x3 MIXED SIGNAL MICROCONTROLLER

SLAS491A – AUGUST 2005 – REVISED OCTOBER 2005

electrical characteristics over recommended ranges of supply voltage and operating free-air temperature (unless otherwise noted) (continued)

wake-up from lower power modes (LPM3/4)

PARAMETER	TEST CONDITIONS	VCC	MIN	TYP	MAX	UNIT
$t_{DCO,LPM3/4}$ DCO clock wake-up time from LPM3/4 (see Note 1)	BCSCTL1= CALBC1_1MHz; DCOCTL = CALDCO_1MHz	2.2 V/3 V			2	μ s
	BCSCTL1= CALBC1_8MHz; DCOCTL = CALDCO_8MHz	2.2 V/3 V			1.5	
	BCSCTL1= CALBC1_12MHz; DCOCTL = CALDCO_12MHz	2.2 V/3 V			1	
	BCSCTL1= CALBC1_16MHz; DCOCTL = CALDCO_16MHz	3 V			1	
$t_{CPU,LPM3/4}$ CPU wake-up time from LPM3/4 (see Note 2)					$1/f_{MCLK} + t_{Clock,LPM3/4}$	

NOTES: 1. The DCO clock wake-up time is measured from the edge of an external wake-up signal (e.g. port interrupt) to the first clock edge observable externally on a clock pin (MCLK or SMCLK).
2. Parameter applicable only if DCOCLK is used for MCLK.

typical characteristics – DCO clock wake-up time from LPM3/4

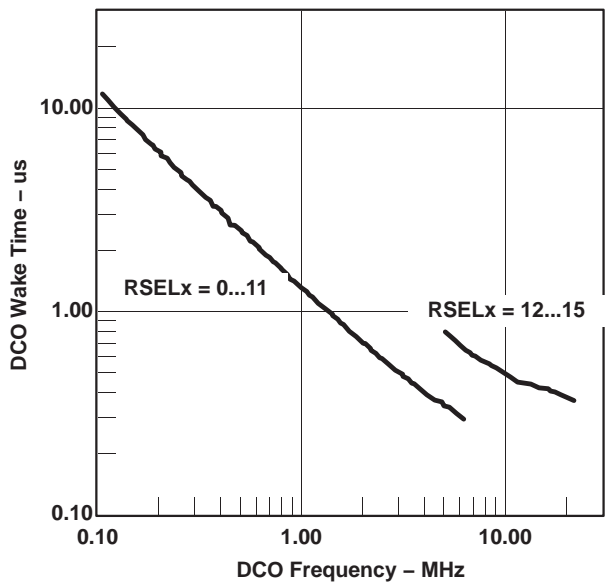

Figure 13. Clock wake-up time from LPM3 vs DCO frequency

MSP430x20x1, MSP430x20x2, MSP430x20x3 MIXED SIGNAL MICROCONTROLLER

SLAS491A – AUGUST 2005 – REVISED OCTOBER 2005

electrical characteristics over recommended ranges of supply voltage and operating free-air temperature (unless otherwise noted) (continued)

crystal oscillator, LFXT1, low frequency modes (see Note 4)

PARAMETER		TEST CONDITIONS	VCC	MIN	TYP	MAX	UNIT
$f_{LFXT1,LF}$	LFXT1 oscillator crystal frequency, LF mode 0, 1	XTS = 0, LFXT1Sx = 0 or 1	1.8 V – 3.6 V		32,768		Hz
$f_{LFXT1,LF,logic}$	LFXT1 oscillator logic level square wave input frequency, LF mode	XTS = 0, LFXT1Sx = 3	1.8 V – 3.6 V	10,000	32,768	50,000	Hz
OA_{LF}	Oscillation Allowance for LF crystals	XTS = 0, LFXT1Sx = 0; $f_{LFXT1,LF} = 32,768$ kHz, $C_{L,eff} = 6$ pF			500		k Ω
		XTS = 0, LFXT1Sx = 0; $f_{LFXT1,LF} = 32,768$ kHz, $C_{L,eff} = 12$ pF			200		k Ω
$C_{L,eff}$	Integrated effective Load Capacitance, LF mode (see Note 1)	XTS = 0, XCAPx = 0			1		pF
		XTS = 0, XCAPx = 1			5.5		pF
		XTS = 0, XCAPx = 2			8.5		pF
		XTS = 0, XCAPx = 3			11		pF
Duty Cycle	LF mode	XTS = 0, Measured at P1.4/ACLK, $f_{LFXT1,LF} = 32,768$ Hz	2.2 V/3 V	30	50	70	%
$f_{Fault,LF}$	Osc. fault frequency threshold, LF mode (see Note 3)	XTS = 0, LFXT1Sx = 3 (see Note 2)	2.2 V/3 V	10		10,000	Hz

- NOTES: 1. Includes parasitic bond and package capacitance (approximately 2pF per pin).
Since the PCB adds additional capacitance it is recommended to verify the correct load by measuring the ACLK frequency. For a correct setup the effective load capacitance should always match the specification of the used crystal.
2. Measured with logic level input frequency but also applies to operation with crystals.
3. Frequencies below the MIN specification will set the fault flag, frequencies above the MAX specification will not set the fault flag. Frequencies in between might set the flag.
4. To improve EMI on the LFXT1 oscillator the following guidelines should be observed.
- Keep as short of a trace as possible between the device and the crystal.
 - Design a good ground plane around the oscillator pins.
 - Prevent crosstalk from other clock or data lines into oscillator pins XIN and XOUT.
 - Avoid running PCB traces underneath or adjacent to the XIN and XOUT pins.
 - Use assembly materials and praxis to avoid any parasitic load on the oscillator XIN and XOUT pins.
 - If conformal coating is used, ensure that it does not induce capacitive/resistive leakage between the oscillator pins.
 - Do not route the XOUT line to the JTAG header to support the serial programming adapter as shown in other documentation. This signal is no longer required for the serial programming adapter.

internal very low power, low frequency oscillator (VLO)

PARAMETER		TEST CONDITIONS	VCC	MIN	TYP	MAX	UNIT
f_{VLO}	VLO frequency		2.2 V/3 V	4	12	20	kHz
df_{VLO}/dT	VLO frequency temperature drift	(see Note 1)	2.2 V/3 V		0.5		%/°C
df_{VLO}/dV_{CC}	VLO frequency supply voltage drift	$T_A = 25^\circ\text{C}$ (see Note 2)	1.8V...3.6V		4		%/V

- NOTES: 1. Calculated using the box method: $(\text{MAX}(-40\dots85^\circ\text{C}) - \text{MIN}(-40\dots85^\circ\text{C})) / \text{MIN}(-40\dots85^\circ\text{C}) / (85^\circ\text{C} - (-40^\circ\text{C}))$
2. Calculated using the box method: $(\text{MAX}(1.8\dots3.6\text{V}) - \text{MIN}(1.8\dots3.6\text{V})) / \text{MIN}(1.8\dots3.6\text{V}) / (3.6\text{V} - 1.8\text{V})$



MSP430x20x1, MSP430x20x2, MSP430x20x3 MIXED SIGNAL MICROCONTROLLER

SLAS491A – AUGUST 2005 – REVISED OCTOBER 2005

electrical characteristics over recommended ranges of supply voltage and operating free-air temperature (unless otherwise noted) (continued)

Timer_A

PARAMETER	TEST CONDITIONS	VCC	MIN	TYP	MAX	UNIT
f _{TA}	Timer_A clock frequency Internal: SMCLK, ACLK; External: TACLK, INCLK; Duty Cycle = 50% ±10%	2.2 V			10	MHz
		3 V			16	
t _{TA,cap}	Timer_A, capture timing	2.2 V/3 V	20			ns

USI, Universal Serial Interface (MSP430x20x2, MSP430x20x3 only)

PARAMETER	TEST CONDITIONS	VCC	MIN	TYP	MAX	UNIT
f _{USI}	USI clock frequency External: SCLK; Duty Cycle = 50% ±10%; SPI Slave Mode	2.2 V			10	MHz
		3 V			16	
V _{OL,I2C}	Low-level output voltage on SDA and SCL USI module in I2C mode I _(OLmax) = 1.5 mA	2.2 V/3 V	V _{SS}		V _{SS} +0.4	V

typical characteristics – USI low-level output voltage on SDA and SCL (MSP430x20x2, MSP430x20x3 only)

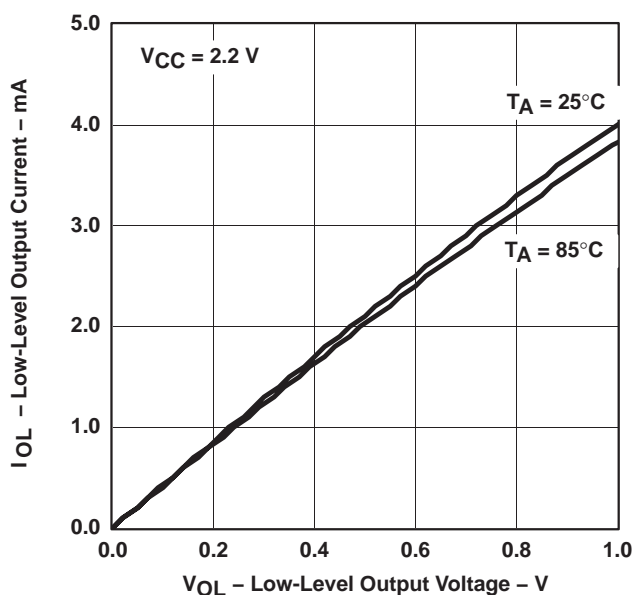

Figure 14. USI Low-Level Output Voltage vs. Output Current

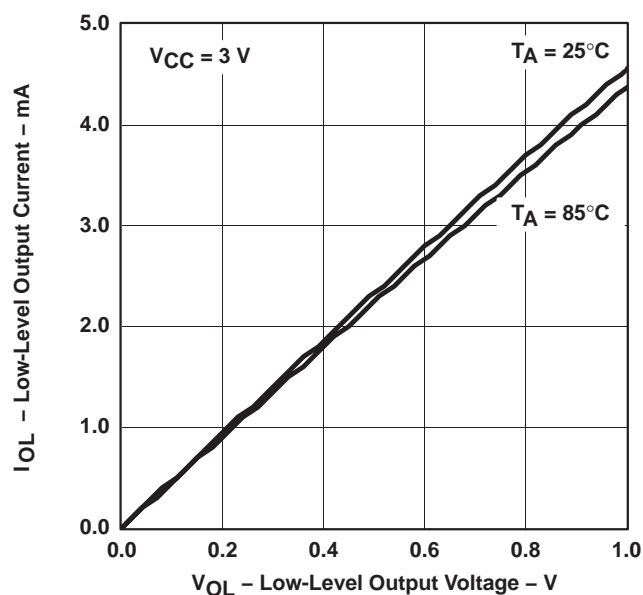

Figure 15. USI Low-Level Output Voltage vs. Output Current

MSP430x20x1, MSP430x20x2, MSP430x20x3 MIXED SIGNAL MICROCONTROLLER

SLAS491A – AUGUST 2005 – REVISED OCTOBER 2005

MSP430x20x1 electrical characteristics over recommended ranges of supply voltage and operating free-air temperature (unless otherwise noted)

Comparator_A+ (see Note 1, MSP430x20x1 only)

PARAMETER		TEST CONDITIONS	VCC	MIN	TYP	MAX	UNIT
I _(DD)		CAON=1, CARSEL=0, CAREF=0	2.2 V		25	40	μA
			3 V		45	60	
I _(RefLadder/RefDiode)		CAON=1, CARSEL=0, CAREF=1/2/3, no load at P1.0/CA0 and P1.1/CA1	2.2 V		30	50	μA
			3 V		45	71	
V _(IC)	Common-mode input voltage	CAON=1	2.2 V/3 V	0		V _{CC} -1	V
V _(Ref025)	$\frac{\text{Voltage @ } 0.25 V_{CC} \text{ node}}{V_{CC}}$	PCA0=1, CARSEL=1, CAREF=1, no load at P1.0/CA0 and P1.1/CA1	2.2 V/3 V	0.23	0.24	0.25	
V _(Ref050)	$\frac{\text{Voltage @ } 0.5 V_{CC} \text{ node}}{V_{CC}}$	PCA0=1, CARSEL=1, CAREF=2, no load at P1.0/CA0 and P1.1/CA1	2.2 V/3 V	0.47	0.48	0.5	
V _(RefVT)	(see Figure 19 and Figure 20)	PCA0=1, CARSEL=1, CAREF=3, no load at P1.0/CA0 and P1.1/CA1, T _A = 85°C	2.2 V	390	480	540	mV
			3 V	400	490	550	
V _(offset)	Offset voltage	See Note 2	2.2 V/3 V	-30		30	mV
V _(hys)	Input hysteresis	CAON=1	2.2 V/3 V	0	0.7	1.4	mV
t _(response)	Response time (low-high and high-low)	T _A = 25°C, Overdrive 10 mV, Without filter: CAF=0 (see Note 3, Figure 16 and Figure 17)	2.2 V	80	165	300	ns
			3 V	70	120	240	
		T _A = 25°C, Overdrive 10 mV, With filter: CAF=1 (see Note 3, Figure 16 and Figure 17)	2.2 V	1.4	1.9	2.8	μs
			3 V	0.9	1.5	2.2	

- NOTES: 1. The leakage current for the Comparator_A+ terminals is identical to I_{lkg}(P_{x.x}) specification.
 2. The input offset voltage can be cancelled by using the CAEX bit to invert the Comparator_A+ inputs on successive measurements. The two successive measurements are then summed together.
 3. Response time measured at P1.3/CAOUT.

MSP430x20x1, MSP430x20x2, MSP430x20x3 MIXED SIGNAL MICROCONTROLLER

SLAS491A – AUGUST 2005 – REVISED OCTOBER 2005

MSP430x20x1 electrical characteristics over recommended ranges of supply voltage and operating free-air temperature (unless otherwise noted) (continued)

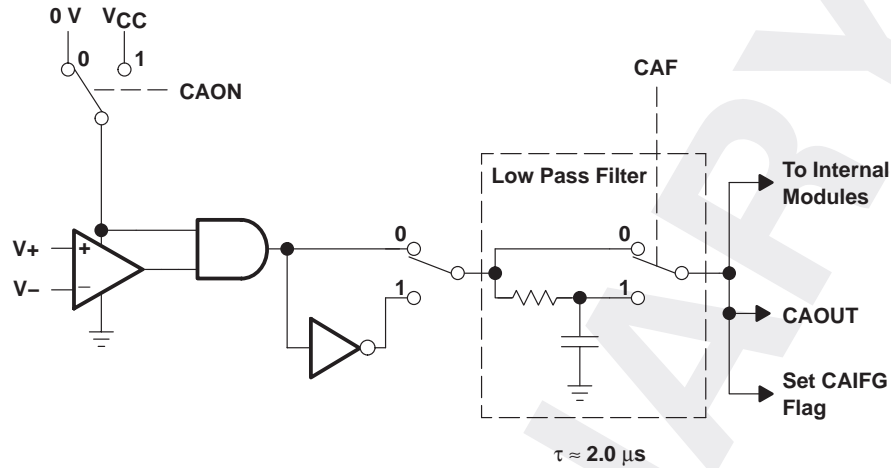

Figure 16. Block Diagram of Comparator_A+ Module

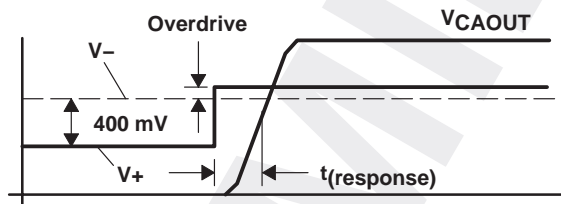

Figure 17. Overdrive Definition

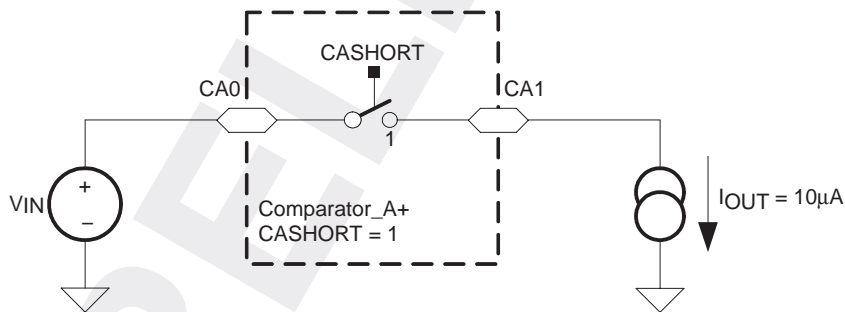

Figure 18. Comparator_A+ Short Resistance Test Condition

MSP430x20x1 electrical characteristics over recommended ranges of supply voltage and operating free-air temperature (unless otherwise noted) (continued)

typical characteristics – Comparator_A+ (MSP430x20x1 only)

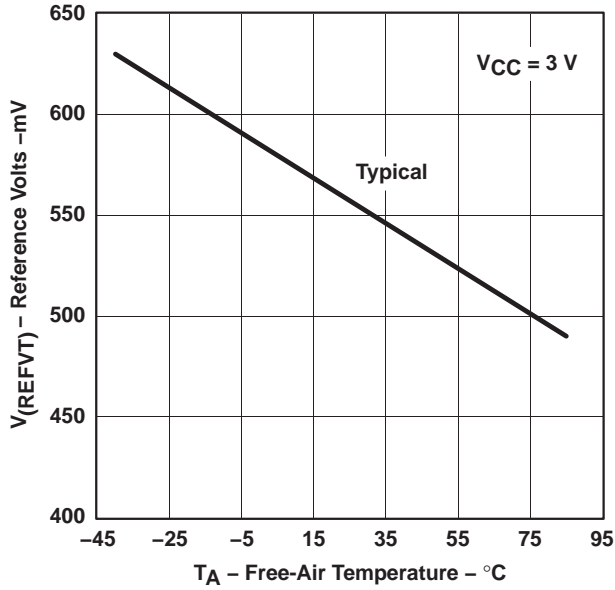

Figure 19. $V_{(RefVT)}$ vs Temperature, $V_{CC} = 3\text{ V}$

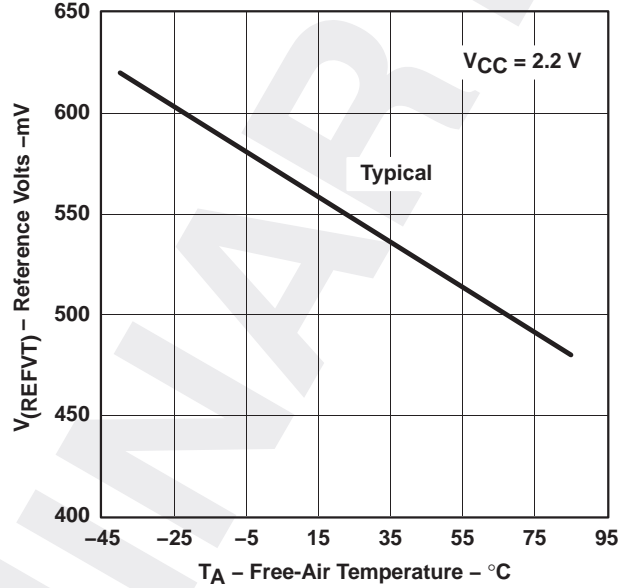

Figure 20. $V_{(RefVT)}$ vs Temperature, $V_{CC} = 2.2\text{ V}$

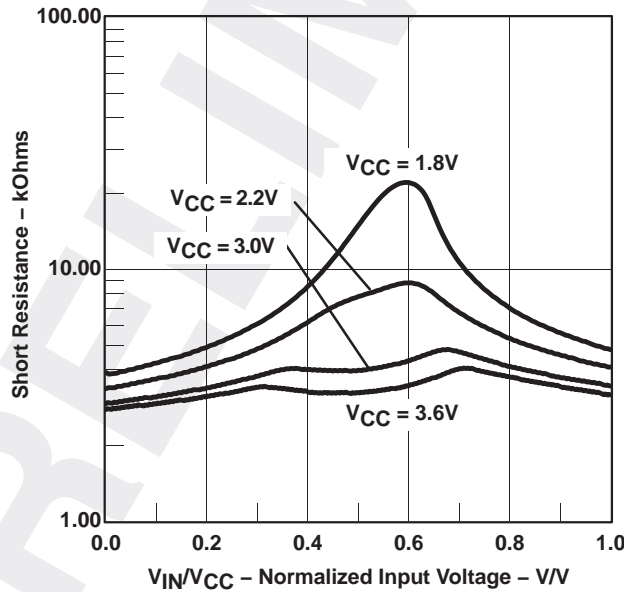

Figure 21. Short Resistance vs V_{IN}/V_{CC}

MSP430x20x1, MSP430x20x2, MSP430x20x3 MIXED SIGNAL MICROCONTROLLER

SLAS491A – AUGUST 2005 – REVISED OCTOBER 2005

MSP430x20x2 electrical characteristics over recommended ranges of supply voltage and operating free-air temperature (unless otherwise noted) (continued)

10-bit ADC, power supply and input range conditions (see Note 1, MSP430x20x2 only)

PARAMETER		TEST CONDITIONS		VCC	MIN	TYP	MAX	UNIT
V _{CC}	Analog supply voltage range	V _{SS} = 0 V			2.2		3.6	V
V _{Ax}	Analog input voltage range (see Note 2)	All Ax terminals. Analog inputs selected in ADC10AE register.			0		V _{CC}	V
I _{ADC10}	ADC10 supply current (see Note 3)	f _{ADC10CLK} = 5.0 MHz ADC10ON = 1, REFON = 0 ADC10SHT0 = 1, ADC10SHT1 = 0, ADC10DIV = 0		2.2 V		0.52	1.05	mA
				3 V		0.6	1.2	
I _{REF+}	Reference supply current, reference buffer disabled (see Note 4)	f _{ADC10CLK} = 5.0 MHz ADC10ON = 0, REFON = 1, REFOUT = 0	REF2_5V=0	2.2 V/3 V		0.25	0.4	mA
			REF2_5V=1	3 V	mA			
I _{REFB}	Reference buffer supply current (see Note 4)	f _{ADC10CLK} = 5.0 MHz ADC10ON = 0, REFON = 1, REF2_5V = 0 REFOUT = 1	ADC10SR=0	2.2 V/3 V		1.1	1.4	mA
			ADC10SR=1	2.2 V/3 V		0.46	0.55	mA
C _I	Input capacitance	Only one terminal Ax selected at a time					27	pF
R _I	Input MUX ON resistance	0V ≤ V _{Ax} ≤ V _{CC}		2.2 V/3 V			2000	Ω

- NOTES: 1. The leakage current is defined in the leakage current table with Px.x/Ax parameter.
 2. The analog input voltage range must be within the selected reference voltage range V_{R+} to V_{R-} for valid conversion results.
 3. The internal reference supply current is not included in current consumption parameter I_{ADC10}.
 4. The internal reference current is supplied via terminal V_{CC}. Consumption is independent of the ADC10ON control bit, unless a conversion is active. The REFON bit enables the built-in reference to settle before starting an A/D conversion.

MSP430x20x1, MSP430x20x2, MSP430x20x3 MIXED SIGNAL MICROCONTROLLER

SLAS491A – AUGUST 2005 – REVISED OCTOBER 2005

MSP430x20x2 electrical characteristics over recommended ranges of supply voltage and operating free-air temperature (unless otherwise noted) (continued)

10-bit ADC, built-in voltage reference (MSP430x20x2 only)

PARAMETER		TEST CONDITIONS		VCC	MIN	TYP	MAX	UNIT
V _{CC,REF+}	Positive built-in reference analog supply voltage range	I _{VREF+} ≤ 1mA, REF2_5V=0			2.2		V _{CC}	V
		I _{VREF+} ≤ 0.5mA, REF2_5V=1			V _{REF+} +0.15		V _{CC}	
		I _{VREF+} ≤ 1mA, REF2_5V=1			V _{REF+} +0.15		V _{CC}	
V _{REF+}	Positive built-in reference voltage	I _{VREF+} ≤ I _{VREF+} max, REF2_5V=0		2.2 V/3 V	1.41	1.5	1.59	V
		I _{VREF+} ≤ I _{VREF+} max, REF2_5V=1		3 V	2.35	2.5	2.65	V
I _{LD,VREF+}	Maximum V _{REF+} load current			2.2 V			±0.5	mA
				3 V			±1	
V _{REF+} load regulation		I _{VREF+} = 500 μA +/- 100 μA Analog input voltage V _{AX} ≈ 0.75 V; REF2_5V=0		2.2 V/3 V			±2	LSB
		I _{VREF+} = 500 μA ± 100 μA Analog input voltage V _{AX} ≈ 1.25 V; REF2_5V=1		3 V			±2	LSB
V _{REF+} load regulation response time		I _{VREF+} = 100μA → 900μA, V _{AX} ≈ 0.5 x V _{REF+} Error of conversion result ≤ 1 LSB	ADC10SR=0	3 V			400	ns
			ADC10SR=1	3V			2000	
C _{VREF+}	Max. capacitance at pin V _{REF+} (see Note 1)	I _{VREF+} ≤ ±1mA, REFON=1, REFOUT=1		2.2 V/3 V			100	pF
TC _{REF+}	Temperature coefficient	I _{VREF+} = const. with 0 mA ≤ I _{VREF+} ≤ 1 mA		2.2 V/3 V			±100	ppm/°C
t _{REFON}	Settling time of internal reference voltage (see Note 2)	I _{VREF+} = 0.5 mA, REF2_5V=0 REFON = 0 → 1		3.6 V			30	μs
t _{REFBURST}	Settling time of reference buffer (see Note 2)	I _{VREF+} = 0.5 mA, REF2_5V=0, REFON = 1, REFBURST = 1	ADC10SR=0	2.2 V			1	
			ADC10SR=1	2.2 V			2.5	

- NOTES: 1. The capacitance applied to the internal buffer operational amplifier, if switched to terminal P2.4/TA2/A4/V_{REF+}/V_{eREF+} (REFOUT=1), must be limited; the reference buffer may become unstable otherwise.
2. The condition is that the error in a conversion started after t_{REFON} or t_{RefBuf} is less than ±0.5 LSB.

MSP430x20x1, MSP430x20x2, MSP430x20x3 MIXED SIGNAL MICROCONTROLLER

SLAS491A – AUGUST 2005 – REVISED OCTOBER 2005

MSP430x20x2 electrical characteristics over recommended ranges of supply voltage and operating free-air temperature (unless otherwise noted) (continued)

10-bit ADC, external reference (see Note 1, MSP430x20x2 only)

PARAMETER		TEST CONDITIONS	VCC	MIN	TYP	MAX	UNIT
V _{eREF+}	Positive external reference input voltage range (see Note 2)	V _{eREF+} > V _{eREF-} SREF1 = 1, SREF0 = 0		1.4		V _{CC}	V
		V _{eREF-} ≤ V _{eREF+} ≤ V _{CC} - 0.15V SREF1 = 1, SREF0 = 1 (see Note 3)		1.4		3.0	V
V _{eREF-}	Negative external reference input voltage range (see Note 4)	V _{eREF+} > V _{eREF-}		0		1.2	V
ΔV _{eREF}	Differential external reference input voltage range ΔV _{eREF} = V _{eREF+} - V _{eREF-}	V _{eREF+} > V _{eREF-} (see Note 5)		1.4		V _{CC}	V
I _{VeREF+}	Static input current into V _{eREF+}	0V ≤ V _{eREF+} ≤ V _{CC} , SREF1 = 1, SREF0 = 0	2.2 V/3 V			±1	μA
		0V ≤ V _{eREF+} ≤ V _{CC} - 0.15V ≤ 3V SREF1 = 1, SREF0 = 1 (see Note 3)	2.2 V/3 V			0	μA
I _{VeREF-}	Static input current into V _{eREF-}	0V ≤ V _{eREF-} ≤ V _{CC}	2.2 V/3 V			±1	μA

- NOTES: 1. The external reference is used during conversion to charge and discharge the capacitance array. The input capacitance, C_I, is also the dynamic load for an external reference during conversion. The dynamic impedance of the reference supply should follow the recommendations on analog-source impedance to allow the charge to settle for 10-bit accuracy.
2. The accuracy limits the minimum positive external reference voltage. Lower reference voltage levels may be applied with reduced accuracy requirements.
3. Under this condition the external reference is internally buffered. The reference buffer is active and requires the reference buffer supply current I_{REFB}. The current consumption can be limited to the sample and conversion period with REBURST = 1.
4. The accuracy limits the maximum negative external reference voltage. Higher reference voltage levels may be applied with reduced accuracy requirements.
5. The accuracy limits the minimum external differential reference voltage. Lower differential reference voltage levels may be applied with reduced accuracy requirements.

MSP430x20x1, MSP430x20x2, MSP430x20x3 MIXED SIGNAL MICROCONTROLLER

SLAS491A – AUGUST 2005 – REVISED OCTOBER 2005

MSP430x20x2 electrical characteristics over recommended ranges of supply voltage and operating free-air temperature (unless otherwise noted) (continued)

10-bit ADC, timing parameters (MSP430x20x2 only)

PARAMETER		TEST CONDITIONS	VCC	MIN	TYP	MAX	UNIT
f _{ADC10CLK}	ADC10 input clock frequency	For specified performance of ADC10 linearity parameters	ADC10SR=0	2.2 V/3 V	0.45	6.3	MHz
			ADC10SR=1	2.2 V/3 V	0.45	1.5	
f _{ADC10OSC}	ADC10 built-in oscillator frequency	ADC10DIVx=0, ADC10SSELx = 0 f _{ADC10CLK} = f _{ADC10OSC}	2.2 V/3 V	3.7		6.3	MHz
t _{CONVERT}	Conversion time	ADC10 built-in oscillator, ADC10SSELx = 0 f _{ADC10CLK} = f _{ADC10OSC}	2.2 V/3 V	2.06		3.51	μs
		f _{ADC10CLK} from ACLK, MCLK or SMCLK: ADC10SSELx ≠ 0			13× ADC10DIV× 1/f _{ADC10CLK}		μs
t _{ADC10ON}	Turn on settling time of the ADC	(see Note 1)				100	ns

NOTES: 1. The condition is that the error in a conversion started after t_{ADC10ON} is less than ±0.5 LSB. The reference and input signal are already settled.

10-bit ADC, linearity parameters (MSP430x20x2 only)

PARAMETER		TEST CONDITIONS	VCC	MIN	TYP	MAX	UNIT
E _I	Integral linearity error		2.2 V/3 V			±1	LSB
E _D	Differential linearity error		2.2 V/3 V			±1	LSB
E _O	Offset error	Source impedance R _S < 100 Ω,	2.2 V/3 V			±1	LSB
E _G	Gain error		2.2 V/3 V		±1.1	±2	LSB
E _T	Total unadjusted error		2.2 V/3 V		±2	±5	LSB

MSP430x20x1, MSP430x20x2, MSP430x20x3 MIXED SIGNAL MICROCONTROLLER

SLAS491A – AUGUST 2005 – REVISED OCTOBER 2005

MSP430x20x2 electrical characteristics over recommended ranges of supply voltage and operating free-air temperature (unless otherwise noted) (continued)

10-bit ADC, temperature sensor and built-in V_{MID} (MSP430x20x2 only)

PARAMETER		TEST CONDITIONS	VCC	MIN	TYP	MAX	UNIT
I_{SENSOR}	Temperature sensor supply current (see Note 1)	REFON = 0, INCHx = 0Ah, $T_A = 25^\circ\text{C}$	2.2 V		40	120	μA
			3 V		60	160	
TC_{SENSOR}^\dagger		ADC10ON = 1, INCHx = 0Ah (see Notes 2, 3)	2.2 V/3 V	3.44	3.55	3.66	$\text{mV}/^\circ\text{C}$
$V_{Offset, Sensor}$	Sensor offset voltage	ADC10ON = 1, INCHx = 0Ah (see Notes 2, 3)		-100		100	mV
V_{Sensor}	Sensor output voltage (see Note 4)	Temperature sensor voltage at $T_A = 85^\circ\text{C}$	2.2 V/3 V	TBD	TBD	TBD	mV
		Temperature sensor voltage at $T_A = 25^\circ\text{C}$	2.2 V/3 V	TBD	TBD	TBD	
		Temperature sensor voltage at $T_A = 0^\circ\text{C}$ (see Note 2)	2.2 V/3 V	935	985	1035	
$t_{Sensor(sample)}$	Sample time required if channel 10 is selected (see Note 5)	ADC10ON = 1, INCHx = 0Ah, Error of conversion result ≤ 1 LSB	2.2 V/3 V	30			μs
I_{VMID}	Current into divider at channel 11 (see Note 6)	ADC10ON = 1, INCHx = 0Bh,	2.2 V			NA	μA
			3 V			NA	
V_{MID}	V_{CC} divider at channel 11	ADC10ON = 1, INCHx = 0Bh, V_{MID} is $\approx 0.5 \times V_{CC}$	2.2 V	1.06	1.1	1.14	V
			3 V	1.46	1.5	1.54	
$t_{VMID(sample)}$	Sample time required if channel 11 is selected (see Note 7)	ADC10ON = 1, INCHx = 0Bh, Error of conversion result ≤ 1 LSB	2.2 V	1400			ns
			3 V	1220			

† Not production tested, limits characterized

- NOTES:
- The sensor current I_{SENSOR} is consumed if (ADC10ON = 1 and REFON = 1), or (ADC10ON=1 and INCH=0Ah and sample signal is high). When REFON = 1, I_{SENSOR} is included in I_{REF+} . When REFON = 0, I_{SENSOR} applies during conversion of the temperature sensor input (INCH = 0Ah).
 - Not production tested, limits characterized.
 - The following formula can be used to calculate the temperature sensor output voltage:
 $V_{Sensor,typ} = TC_{Sensor} (273 + T [^\circ\text{C}]) + V_{Offset,sensor} [\text{mV}]$ or
 $V_{Sensor,typ} = TC_{Sensor} T [^\circ\text{C}] + V_{Sensor}(T_A = 0^\circ\text{C}) [\text{mV}]$
 - Results based on characterization and/or production test, not TC_{Sensor} or $V_{Offset,sensor}$.
 - The typical equivalent impedance of the sensor is 51 k Ω . The sample time required includes the sensor-on time $t_{SENSOR(on)}$.
 - No additional current is needed. The V_{MID} is used during sampling.
 - The on-time $t_{VMID(on)}$ is included in the sampling time $t_{VMID(sample)}$; no additional on time is needed.

MSP430x20x1, MSP430x20x2, MSP430x20x3 MIXED SIGNAL MICROCONTROLLER

SLAS491A – AUGUST 2005 – REVISED OCTOBER 2005

MSP430x20x3 electrical characteristics over recommended ranges of supply voltage and operating free-air temperature (unless otherwise noted)

SD16_A, power supply and recommended operating conditions (MSP430x20x3 only)

PARAMETER		TEST CONDITIONS	VCC	MIN	TYP	MAX	UNIT
V_{CC}	Analog supply voltage range	$AV_{CC} = DV_{CC} = V_{CC}$ $AV_{SS} = DV_{SS} = V_{SS} = 0V$		2.5		3.6	V
I_{SD16}	Analog supply current including internal reference	SD16LP = 0, $f_{SD16} = 1$ MHz, SD16OSR = 256	GAIN: 1,2	3 V	730	1050	μA
			GAIN: 4,8,16	3 V	810	1150	
		SD16LP = 1, $f_{SD16} = 0.5$ MHz, SD16OSR = 256	GAIN: 32	3 V	1160	1700	
			GAIN: 1	3 V	720	1030	
f_{SD16}	SD16 input clock frequency	SD16LP = 0 (Low power mode disabled)	3 V	0.03	1	1.1	MHz
		SD16LP = 1 (Low power mode enabled)	3 V	0.03	0.5		

SD16_A, input range (MSP430x20x3 only)

PARAMETER		TEST CONDITIONS	VCC	MIN	TYP	MAX	UNIT
$V_{ID,FSR}$	Differential full scale input voltage range (see Note 1)	Bipolar Mode, SD16UNI = 0		$-(V_{REF}/2)/GAIN$		$+(V_{REF}/2)/GAIN$	mV
		Unipolar Mode, SD16UNI = 1		0		$+(V_{REF}/2)/GAIN$	mV
V_{ID}	Differential input voltage range for specified performance (see Note 1)	SD16REFON=1	SD16GAINx=1		± 500		mV
			SD16GAINx=2		± 250		
			SD16GAINx=4		± 125		
			SD16GAINx=8		± 62		
			SD16GAINx=16		± 31		
			SD16GAINx=32		± 15		
Z_I	Input impedance (one input pin to AV_{SS})	$f_{SD16} = 1$ MHz	SD16GAINx=1	3 V	200		k Ω
			SD16GAINx=32	3 V	75		
Z_{ID}	Differential Input impedance (IN+ to IN-)	$f_{SD16} = 1$ MHz	SD16GAINx=1	3 V	300	400	k Ω
			SD16GAINx=32	3 V	100	150	
V_I	Absolute input voltage range			AV_{SS} -0.1V		AV_{CC}	V
V_{IC}	Common-mode input voltage range			AV_{SS} -0.1V		AV_{CC}	V

NOTES: 1. The analog input range depends on the reference voltage applied to V_{REF} . If V_{REF} is sourced externally, the full-scale range is defined by $V_{FSR+} = +(V_{REF}/2)/GAIN$ and $V_{FSR-} = -(V_{REF}/2)/GAIN$. The analog input range should not exceed 80% of V_{FSR+} or V_{FSR-} .

MSP430x20x1, MSP430x20x2, MSP430x20x3 MIXED SIGNAL MICROCONTROLLER

SLAS491A – AUGUST 2005 – REVISED OCTOBER 2005

MSP430x20x3 electrical characteristics over recommended ranges of supply voltage and operating free-air temperature (unless otherwise noted) (continued)

SD16_A, SINAD performance ($f_{SD16} = 1\text{MHz}$, $SD16OSRx = 1024$, $SD16REFON = 1$, MSP430x20x3 only)

PARAMETER	TEST CONDITIONS	VCC	PW, or N		RSA		UNIT
			MIN	TYP	MIN	TYP	
SINAD ₁₀₂₄ Signal-to-Noise + Distortion Ratio (OSR = 1024)	SD16GAINx = 1, Signal Amplitude: $V_{IN} = 500\text{mV}$, Signal Frequency: $f_{IN} = 100\text{Hz}$	3 V	84	85	TBD	TBD	dB
	SD16GAINx = 2, Signal Amplitude: $V_{IN} = 250\text{mV}$, Signal Frequency: $f_{IN} = 100\text{Hz}$	3 V	82	83	TBD	TBD	
	SD16GAINx = 4, Signal Amplitude: $V_{IN} = 125\text{mV}$, Signal Frequency: $f_{IN} = 100\text{Hz}$	3 V	78	79	TBD	TBD	
	SD16GAINx = 8, Signal Amplitude: $V_{IN} = 62\text{mV}$, Signal Frequency: $f_{IN} = 100\text{Hz}$	3 V	73	74	TBD	TBD	
	SD16GAINx = 16, Signal Amplitude: $V_{IN} = 31\text{mV}$, Signal Frequency: $f_{IN} = 100\text{Hz}$	3 V	68	69	TBD	TBD	
	SD16GAINx = 32, Signal Amplitude: $V_{IN} = 15\text{mV}$, Signal Frequency: $f_{IN} = 100\text{Hz}$	3 V	62	63	TBD	TBD	

SD16_A, SINAD performance ($f_{SD16} = 1\text{MHz}$, $SD16OSRx = 256$, $SD16REFON = 1$, MSP430x20x3 only)

PARAMETER	TEST CONDITIONS	VCC	PW, or N		RSA		UNIT
			MIN	TYP	MIN	TYP	
SINAD ₂₅₆ Signal-to-Noise + Distortion Ratio (OSR = 256)	SD16GAINx = 1, Signal Amplitude: $V_{IN} = 500\text{mV}$, Signal Frequency: $f_{IN} = 100\text{Hz}$	3 V	80	81	TBD	TBD	dB
	SD16GAINx = 2, Signal Amplitude: $V_{IN} = 250\text{mV}$, Signal Frequency: $f_{IN} = 100\text{Hz}$	3 V	74	75	TBD	TBD	
	SD16GAINx = 4, Signal Amplitude: $V_{IN} = 125\text{mV}$, Signal Frequency: $f_{IN} = 100\text{Hz}$	3 V	69	70	TBD	TBD	
	SD16GAINx = 8, Signal Amplitude: $V_{IN} = 62\text{mV}$, Signal Frequency: $f_{IN} = 100\text{Hz}$	3 V	63	64	TBD	TBD	
	SD16GAINx = 16, Signal Amplitude: $V_{IN} = 31\text{mV}$, Signal Frequency: $f_{IN} = 100\text{Hz}$	3 V	58	59	TBD	TBD	
	SD16GAINx = 32, Signal Amplitude: $V_{IN} = 15\text{mV}$, Signal Frequency: $f_{IN} = 100\text{Hz}$	3 V	52	53	TBD	TBD	



MSP430x20x1, MSP430x20x2, MSP430x20x3 MIXED SIGNAL MICROCONTROLLER

SLAS491A – AUGUST 2005 – REVISED OCTOBER 2005

MSP430x20x3 electrical characteristics over recommended ranges of supply voltage and operating free-air temperature (unless otherwise noted) (continued)

typical characteristics – SD16_A SINAD performance over OSR (MSP430x20x3 only)

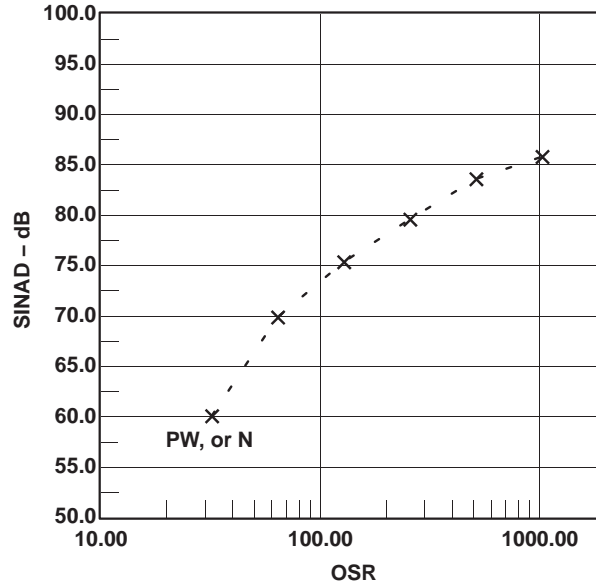

Figure 22. SINAD performance over OSR, $f_{SD16} = 1\text{MHz}$, $SD16REFON = 1$, $SD16GAINx = 1$

SD16_A, performance ($f_{SD16} = 1\text{MHz}$, $SD16OSRx = 256$, $SD16REFON = 1$, MSP430x20x3 only)

PARAMETER	TEST CONDITIONS	VCC	MIN	TYP	MAX	UNIT
G Nominal Gain (see Note 1)	SD16GAINx = 1	3 V	0.97	1.00	1.02	
	SD16GAINx = 2	3 V	1.90	1.96	2.02	
	SD16GAINx = 4	3 V	3.76	3.86	3.96	
	SD16GAINx = 8	3 V	7.36	7.62	7.84	
	SD16GAINx = 16	3 V	14.56	15.04	15.52	
	SD16GAINx = 32	3 V	27.20	28.35	29.76	
dG/dT Gain Temperature Drift	SD16GAINx = 1 (see Note 2)	3 V	15			ppm/°C
dG/dVCC Gain Supply Voltage Drift	SD16GAINx = 1; $V_{CC} = 2.5\text{V} - 3.6\text{V}$ (see Note 3)	2.5V-3.6V	0.35			%/V
EOS Offset Error (see Note 1)	SD16GAINx = 1	3 V			±0.2	%FSR
	SD16GAINx = 32	3 V			±1.5	
dEOS/dT Offset Error Temperature Coefficient (see Note 1)	SD16GAINx = 1	3 V			±4 ±20	ppm FSR/°C
	SD16GAINx = 32	3 V			±20 ±100	
CMRR Common-Mode Rejection Ratio	SD16GAINx = 1, Common-mode input signal: $V_{ID} = 500\text{ mV}$, $f_{IN} = 50\text{ Hz}$, 100 Hz	3 V			>90	dB
	SD16GAINx = 32, Common-mode input signal: $V_{ID} = 16\text{ mV}$, $f_{IN} = 50\text{ Hz}$, 100 Hz	3 V			>75	
PSRR Power Supply Rejection Ratio	SD16GAINx = 1	3 V			>80	dB

- NOTES: 1. Not production tested, limits characterized.
 2. Calculated using the box method: $(\text{MAX}(-40\dots85^\circ\text{C}) - \text{MIN}(-40\dots85^\circ\text{C})) / \text{MIN}(-40\dots85^\circ\text{C}) / (85^\circ\text{C} - (-40^\circ\text{C}))$
 3. Calculated using the box method: $(\text{MAX}(2.5\dots3.6\text{V}) - \text{MIN}(2.5\dots3.6\text{V})) / \text{MIN}(2.5\dots3.6\text{V}) / (3.6\text{V} - 2.5\text{V})$



MSP430x20x1, MSP430x20x2, MSP430x20x3 MIXED SIGNAL MICROCONTROLLER

SLAS491A – AUGUST 2005 – REVISED OCTOBER 2005

MSP430x20x3 electrical characteristics over recommended ranges of supply voltage and operating free-air temperature (unless otherwise noted) (continued)

SD16_A, temperature sensor (MSP430x20x3 only)

PARAMETER		TEST CONDITIONS	VCC	MIN	TYP	MAX	UNIT
TC _{Sensor}	Sensor temperature coefficient	See Note 1		1.18	1.32	1.46	mV/K
V _{Offset,Sensor}	Sensor offset voltage	See Note 1		-100		100	mV
V _{Sensor}	Sensor output voltage (see Note 3)	Temperature sensor voltage at T _A = 85°C	3 V	435	475	515	mV
		Temperature sensor voltage at T _A = 25°C	3 V	355	395	435	
		Temperature sensor voltage at T _A = 0°C (see Note 1)	3 V	320	360	400	

- NOTES: 1. Not production tested, limits characterized.
 2. The following formula can be used to calculate the temperature sensor output voltage:
 $V_{\text{Sensor,typ}} = TC_{\text{Sensor}} (273 + T [^{\circ}\text{C}]) + V_{\text{Offset,sensor}} [\text{mV}]$ or
 $V_{\text{Sensor,typ}} = TC_{\text{Sensor}} T [^{\circ}\text{C}] + V_{\text{Sensor}}(T_A = 0^{\circ}\text{C}) [\text{mV}]$
 3. Results based on characterization and/or production test, not TC_{Sensor} or V_{Offset,sensor}.

SD16_A, built-in voltage reference (MSP430x20x3 only)

PARAMETER		TEST CONDITIONS	VCC	MIN	TYP	MAX	UNIT
V _{REF}	Internal reference voltage	SD16REFON = 1, SD16VMIDON = 0	3 V	1.14	1.20	1.26	V
I _{REF}	Reference supply current	SD16REFON = 1, SD16VMIDON = 0	3 V		190	280	μA
TC	Temperature coefficient	SD16REFON = 1, SD16VMIDON = 0	3 V		18	50	ppm/K
C _{REF}	V _{REF} load capacitance	SD16REFON = 1, SD16VMIDON = 0 (see Note 1)			100		nF
I _{LOAD}	V _{REF(I)} maximum load current	SD16REFON = 1; SD16VMIDON = 0	3 V			±200	nA
t _{ON}	Turn on time	SD16REFON = 0 → 1; SD16VMIDON = 0; C _{REF} = 100nF	3 V		5		ms
PSRR	Line regulation	SD16REFON = 1; SD16VMIDON = 0	3 V		10		uV/V

- NOTES: 1. There is no capacitance required on V_{REF}. However, a capacitance of at least 100nF is recommended to reduce any reference voltage noise.

SD16_A, reference output buffer (MSP430x20x3 only)

PARAMETER		TEST CONDITIONS	VCC	MIN	TYP	MAX	UNIT
V _{REF,BUF}	Reference buffer output voltage	SD16REFON = 1, SD16VMIDON = 1	3 V		1.2		V
I _{REF,BUF}	Reference Supply + Reference output buffer quiescent current	SD16REFON = 1, SD16VMIDON = 1	3 V		385	600	μA
C _{REF(O)}	Required load capacitance on V _{REF}	SD16REFON = 1, SD16VMIDON = 1		470			nF
I _{LOAD,Max}	Maximum load current on V _{REF}	SD16REFON = 1, SD16VMIDON = 1	3 V			±1	mA
Maximum voltage variation vs. load current		I _{LOAD} = 0 to 1mA	3 V	-15		+15	mV
t _{ON}	Turn on time	SD16REFON = 0 → 1; SD16VMIDON = 1; C _{REF} = 470nF	3 V		100		μs

SD16_A, external reference input (MSP430x20x3 only)

PARAMETER		TEST CONDITIONS	VCC	MIN	TYP	MAX	UNIT
V _{REF(I)}	Input voltage range	SD16REFON = 0	3 V	1.0	1.25	1.5	V
I _{REF(I)}	Input current	SD16REFON = 0	3 V			50	nA



MSP430x20x1, MSP430x20x2, MSP430x20x3 MIXED SIGNAL MICROCONTROLLER

SLAS491A – AUGUST 2005 – REVISED OCTOBER 2005

electrical characteristics over recommended ranges of supply voltage and operating free-air temperature (unless otherwise noted) (continued)

Flash Memory

PARAMETER		TEST CONDITIONS	VCC	MIN	TYP	MAX	UNIT
V _{CC(PGM/ERASE)}	Program and Erase supply voltage			2.2		3.6	V
f _{FTG}	Flash Timing Generator frequency			257		476	kHz
I _{PGM}	Supply current from V _{CC} during program		2.2 V/3.6 V		1	5	mA
I _{ERASE}	Supply current from V _{CC} during erase		2.2 V/3.6 V		1	7	mA
t _{CPT}	Cumulative program time (see Note 1)		2.2 V/3.6 V			10	ms
t _{CMErase}	Cumulative mass erase time		2.2 V/3.6 V	20			ms
	Program/Erase endurance			10 ⁴	10 ⁵		cycles
t _{Retention}	Data retention duration	T _J = 25°C		100			years
t _{Word}	Word or byte program time	see Note 2			30		t _{FTG}
t _{Block, 0}	Block program time for 1 st byte or word				25		
t _{Block, 1-63}	Block program time for each additional byte or word				18		
t _{Block, End}	Block program end-sequence wait time				6		
t _{Mass Erase}	Mass erase time				10593		
t _{Seg Erase}	Segment erase time				4819		

- NOTES: 1. The cumulative program time must not be exceeded when writing to a 64-byte flash block. This parameter applies to all programming methods: individual word/byte write and block write modes.
2. These values are hardwired into the Flash Controller's state machine (t_{FTG} = 1/f_{FTG}).

RAM

PARAMETER		TEST CONDITIONS	MIN	TYP	MAX	UNIT
V _(RAMh)	RAM retention supply voltage (see Note 1)	CPU halted	1.6			V

NOTE 1: This parameter defines the minimum supply voltage V_{CC} when the data in RAM remains unchanged. No program execution should happen during this supply voltage condition.

MSP430x20x1, MSP430x20x2, MSP430x20x3 MIXED SIGNAL MICROCONTROLLER

SLAS491A – AUGUST 2005 – REVISED OCTOBER 2005

electrical characteristics over recommended ranges of supply voltage and operating free-air temperature (unless otherwise noted) (continued)

JTAG and Spy-Bi-Wire Interface

PARAMETER		TEST CONDITIONS	VCC	MIN	TYP	MAX	UNIT
f _{SBW}	Spy-Bi-Wire input frequency		2.2 V / 3 V	0		20	MHz
t _{SBW,Low}	Spy-Bi-Wire low clock pulse length		2.2 V / 3 V	0.025		15	us
t _{SBW,En}	Spy-Bi-Wire enable time (TEST high to acceptance of first clock edge, see Note 1)		2.2 V / 3 V			1	us
t _{SBW,Ret}	Spy-Bi-Wire return to normal operation time		2.2 V / 3 V	15		100	us
f _{TCK}	TCK input frequency – 4-wire JTAG (see Note 2)		2.2 V	0		5	MHz
			3 V	0		10	MHz
R _{Internal}	Internal pull-down resistance on TEST		2.2 V / 3 V	25	60	90	kΩ

- NOTES: 1. Tools accessing the Spy-Bi-Wire interface need to wait for the maximum t_{SBW,En} time after pulling the TEST/SBWCLK pin high before applying the first SBWCLK clock edge.
2. f_{TCK} may be restricted to meet the timing requirements of the module selected.

JTAG Fuse (see Note 1)

PARAMETER		TEST CONDITIONS	VCC	MIN	TYP	MAX	UNIT
V _{CC(FB)}	Supply voltage during fuse-blow condition	T _A = 25°C		2.5			V
V _{FB}	Voltage level on TEST for fuse-blow			6		7	V
I _{FB}	Supply current into TEST during fuse blow					100	mA
t _{FB}	Time to blow fuse					1	ms

- NOTES: 1. Once the fuse is blown, no further access to the JTAG/Test, Spy-Bi-Wire, and emulation feature is possible and JTAG is switched to bypass mode.

MSP430x20x1, MSP430x20x2, MSP430x20x3 MIXED SIGNAL MICROCONTROLLER

SLAS491A – AUGUST 2005 – REVISED OCTOBER 2005

APPLICATION INFORMATION, MSP430x20x1

Port P1 (P1.0 to P1.3) pin functions, MSP430x20x1

PIN NAME (P1.X)	X	FUNCTION	CONTROL BITS / SIGNALS		
			P1DIR.x	P1SEL.x	CAPD.x
P1.0/TACLK/ACLK/ CA0	0	P1.0† Input/Output	0/1	0	0
		Timer_A2.TACLK/ <u>INCLK</u>	0	1	0
		ACLK	1	1	0
		CA0 (see Note 3)	X	X	1
P1.1/TA0/CA1	1	P1.1† Input/Output	0/1	0	0
		Timer_A2.CCI0A	0	1	0
		Timer_A2.TA0	1	1	0
		CA1 (see Note 3)	X	X	1
P1.2/TA1/CA2	2	P1.2† Input/Output	0/1	0	0
		Timer_A2.CCI1A	0	1	0
		Timer_A2.TA1	1	1	0
		CA2 (see Note 3)	X	X	1
P1.3/CAOUT/CA3	3	P1.3† Input/Output	0/1	0	0
		N/A	0	1	0
		CAOUT	1	1	0
		CA3 (see Note 3)	X	X	1

† Default after reset (PUC/POR)

NOTES: 1. N/A: Not available or not applicable.

2. X: Don't care.

3. Setting the CAPD.x bit disables the output driver as well as the input schmitt trigger to prevent parasitic cross currents when applying analog signals. Selecting the CAx input pin to the comparator multiplexer with the P2CAx bits automatically disables the input buffer for that pin, regardless of the state of the associated CAPD.x bit.

MSP430x20x1, MSP430x20x2, MSP430x20x3 MIXED SIGNAL MICROCONTROLLER

SLAS491A – AUGUST 2005 – REVISED OCTOBER 2005

Port P1 (P1.0 to P1.3) pin schematics, MSP430x20x1

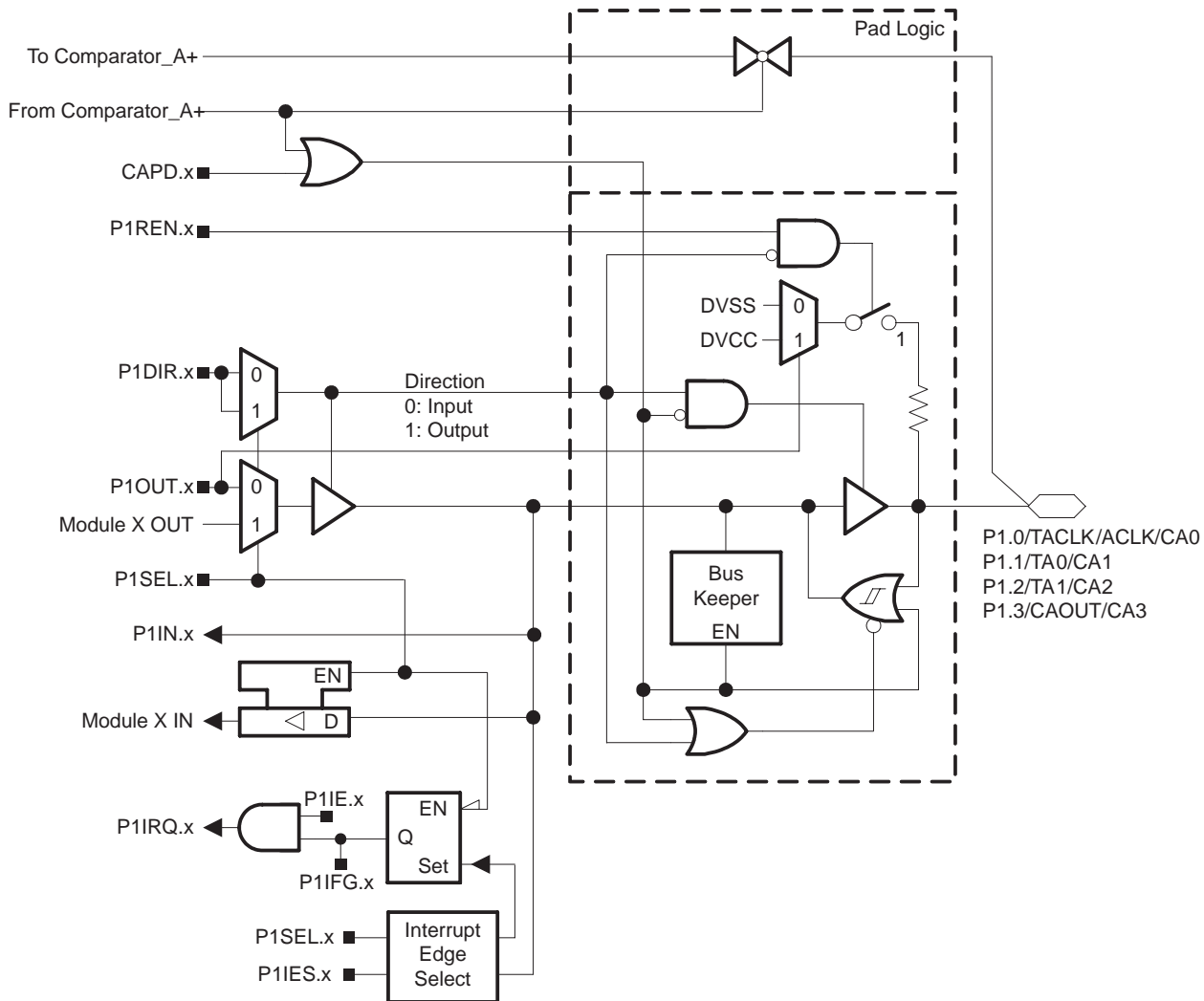

Control signal “From Comparator_A+”

PIN NAME	FUNCTION	SIGNAL “FROM COMPARATOR_A+” = 1					
		P2CA4	P2CA0	OR	P2CA3	P2CA2	P2CA1
P1.0/TACLK/ACLK/CA0	CA0	0	1		N/A	N/A	N/A
P1.1/TA0/CA1	CA1	1	0		0	0	1
P1.2/TA1/CA2	CA2	1	1		0	1	0
P1.3/CAOUT/CA3	CA3	N/A	N/A	0	1	1	

NOTES: 1. N/A: Not available or not applicable.

MSP430x20x1, MSP430x20x2, MSP430x20x3 MIXED SIGNAL MICROCONTROLLER

SLAS491A – AUGUST 2005 – REVISED OCTOBER 2005

Port P1 (P1.4 to P1.7) pin functions, MSP430x20x1

PIN NAME (P1.X)	X	FUNCTION	CONTROL BITS / SIGNALS			
			P1DIR.x	P1SEL.x	CAPD.x	JTAG Mode
P1.4/SMCLK/CA4/ TCK	4	P1.4† Input/Output	0/1	0	0	0
		N/A	0	1	0	0
		SMCLK	1	1	0	0
		CA4 (see Note 3)	X	X	1	0
		TCK (see Note 4)	X	X	X	1
P1.5/TA0/CA5/ TMS	5	P1.5† Input/Output	0/1	0	0	0
		N/A	0	1	0	0
		Timer_A2.TA0	1	1	0	0
		CA5 (see Note 3)	X	X	1	0
		TMS (see Note 4)	X	X	X	1
P1.6/TA1/CA6/ TDI	6	P1.6† Input/Output	0/1	0	0	0
		N/A	0	1	0	0
		Timer_A2.TA1	1	1	0	0
		CA6 (see Note 3)	X	X	1	0
		TDI (see Note 4)	X	X	X	1
P1.7/CAOUT/CA7/ TDO/TDI	7	P1.7† Input/Output	0/1	0	0	0
		N/A	0	1	0	0
		CAOUT	1	1	0	0
		CA7 (see Note 3)	X	X	1	0
		TDO/TDI (see Notes 4, 5)	X	X	X	1

† Default after reset (PUC/POR)

- NOTES:
1. N/A: Not available or not applicable.
 2. X: Don't care.
 3. Setting the CAPD.x bit disables the output driver as well as the input schmitt trigger to prevent parasitic cross currents when applying analog signals. Selecting the CAx input pin to the comparator multiplexer with the P2CAx bits automatically disables the input buffer for that pin, regardless of the state of the associated CAPD.x bit.
 4. In JTAG mode the internal pull-up/down resistors are disabled.
 5. Function controlled by JTAG

MSP430x20x1, MSP430x20x2, MSP430x20x3 MIXED SIGNAL MICROCONTROLLER

SLAS491A – AUGUST 2005 – REVISED OCTOBER 2005

Port P1 (P1.4 to P1.6) pin schematics, MSP430x20x1

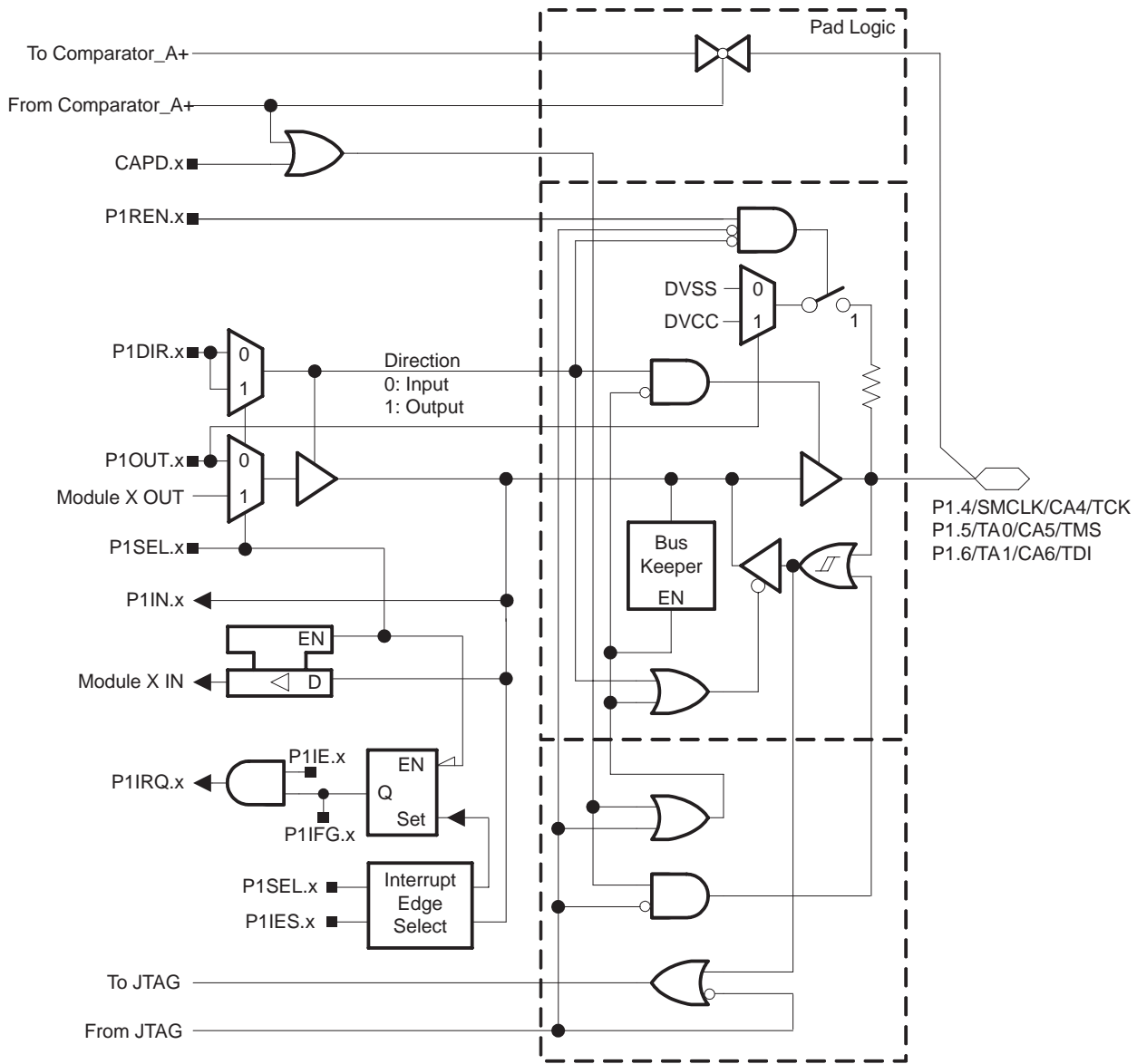

Control signal “From Comparator_A+”

PIN NAME	FUNCTION	SIGNAL “FROM COMPARATOR_A+” = 1		
		P2CA3	P2CA2	P2CA1
P1.4/SMCLK/CA4/TCK	CA4	1	0	0
P1.5/TA0/CA5/TMS	CA5	1	0	1
P1.6/TA1/CA6/TDI	CA6	1	1	0

NOTES: 1. N/A: Not available or not applicable.

Port P1 (P1.7) pin schematics, MSP430x20x1

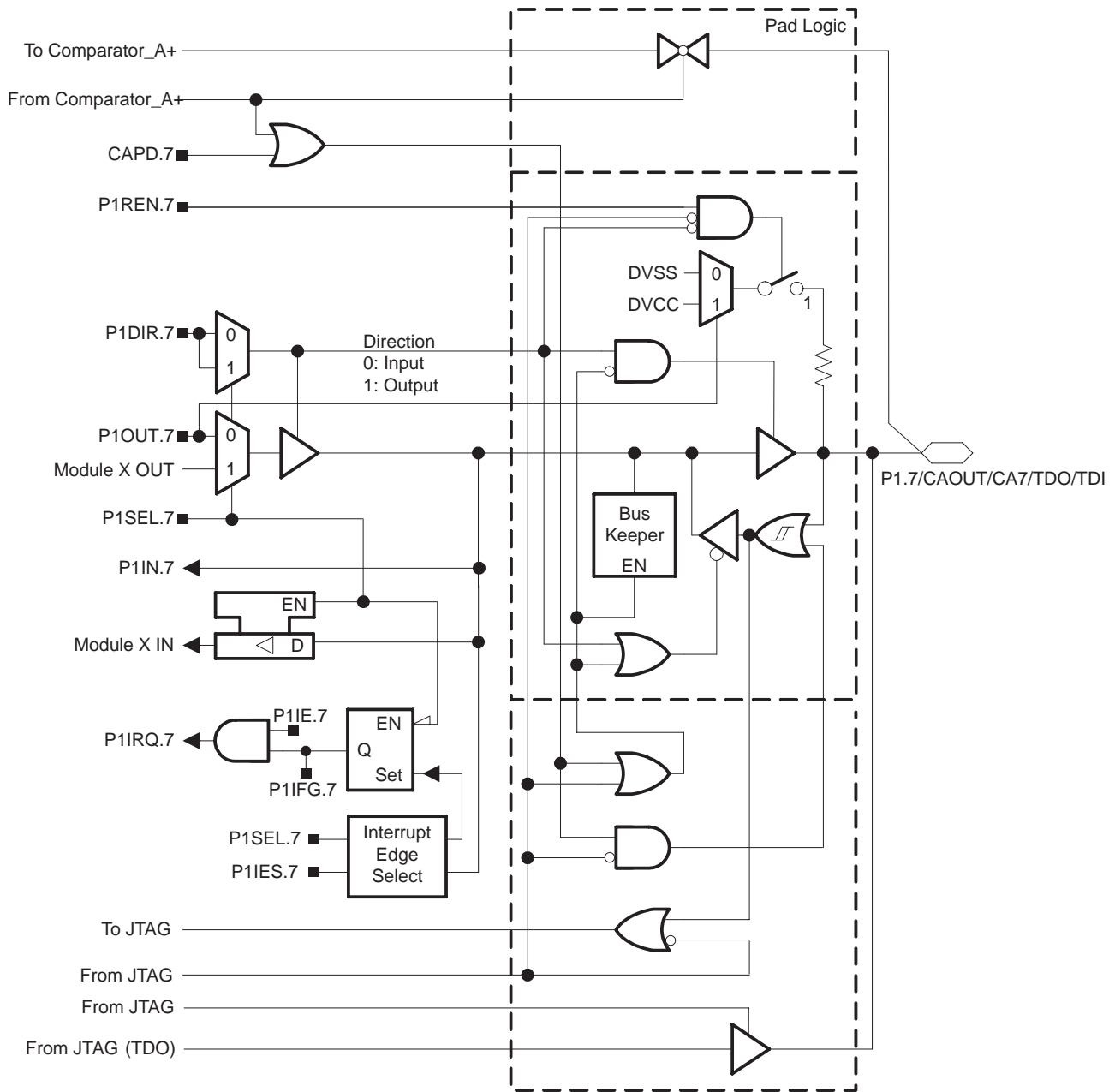

Control signal "From Comparator_A+"

PIN NAME	FUNCTION	SIGNAL "FROM COMPARATOR_A+" = 1		
		P2CA3	P2CA2	P2CA1
P1.7/CAOUT/CA7/TDO/TDI	CA7	1	1	1

NOTES: 1. N/A: Not available or not applicable.

MSP430x20x1, MSP430x20x2, MSP430x20x3 MIXED SIGNAL MICROCONTROLLER

SLAS491A – AUGUST 2005 – REVISED OCTOBER 2005

Port P2 (P2.6) pin schematics, MSP430x20x1

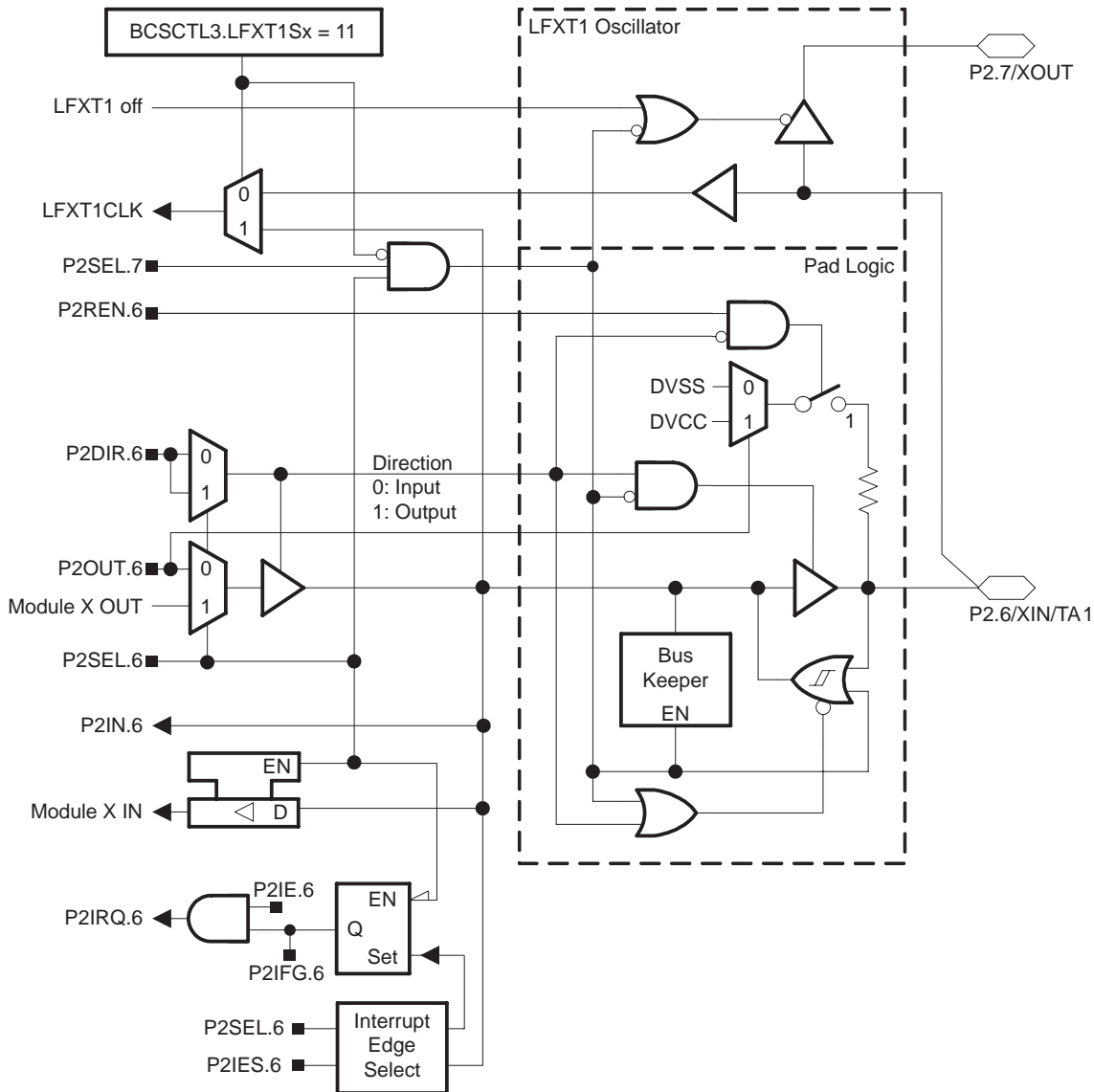

Port P2 (P2.6) pin functions, MSP430x20x1

PIN NAME (P2.X)	X	FUNCTION	CONTROL BITS / SIGNALS	
			P2DIR.x	P2SEL.x
P2.6/XIN/TA1	6	P2.6 Input/Output	0/1	0
		XIN† (see Note 3)	0	1
		Timer_A2.TA1	1	1

† Default after reset (PUC/POR)

NOTES: 1. N/A: Not available or not applicable.

2. X: Don't care.

3. XIN is used as digital clock input if the bits LFXT1Sx in register BCCTL3 are set to 11.

Port P2 (P2.7) pin schematics, MSP430x20x1

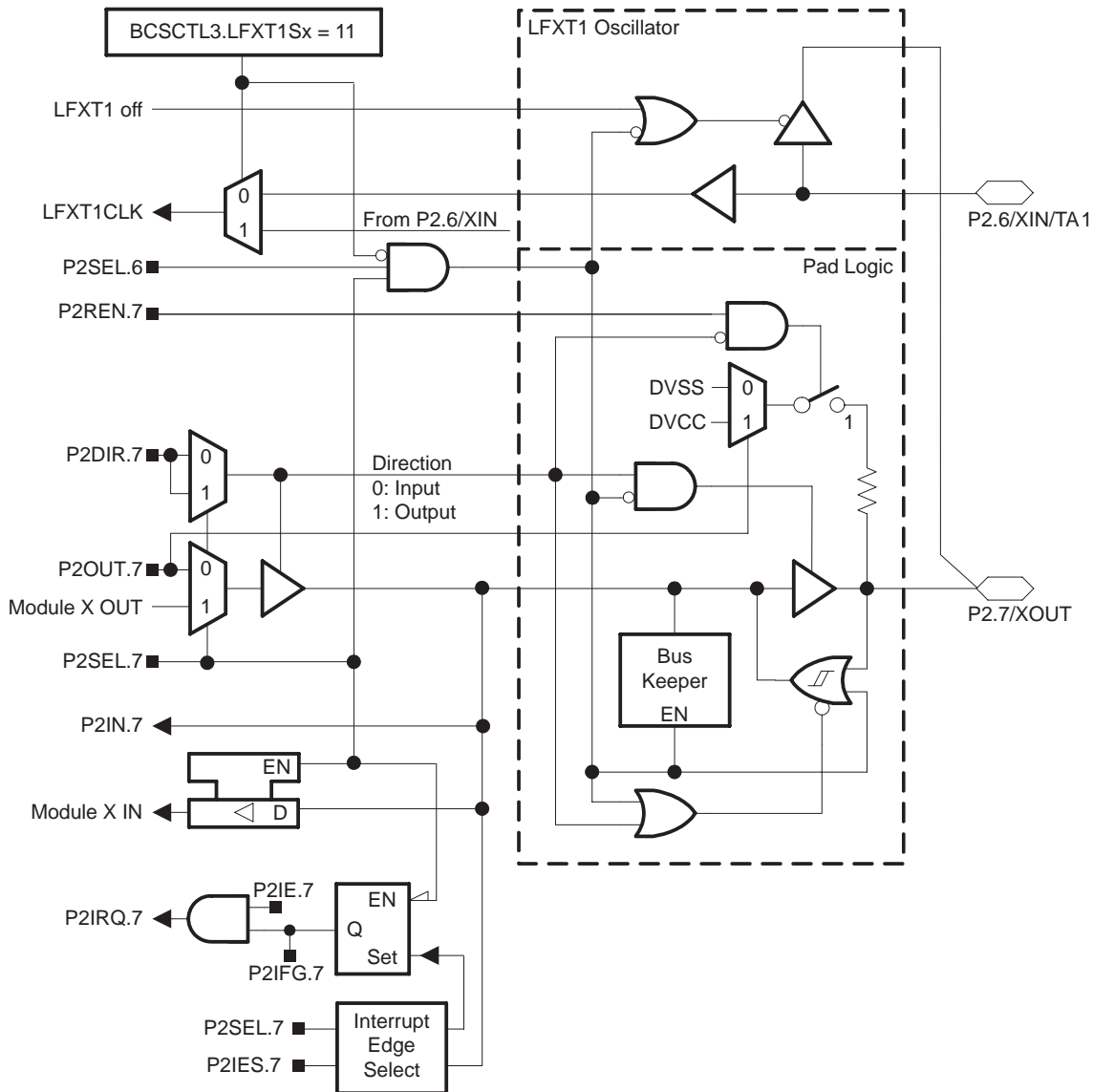

Port P2 (P2.7) pin functions, MSP430x20x1

PIN NAME (P2.X)	X	FUNCTION	CONTROL BITS / SIGNALS	
			P2DIR.x	P2SEL.x
P2.7/XOUT	7	P2.7 Input/Output	0/1	0
		DVSS	0	1
		XOUT† (see Note 3)	1	1

† Default after reset (PUC/POR)

NOTES: 1. N/A: Not available or not applicable.

2. X: Don't care.

3. If the pin P2.7/XOUT is used as an input a current can flow until P2SEL.7 is cleared due to the oscillator output driver connection to this pin after reset.

MSP430x20x1, MSP430x20x2, MSP430x20x3 MIXED SIGNAL MICROCONTROLLER

SLAS491A – AUGUST 2005 – REVISED OCTOBER 2005

APPLICATION INFORMATION, MSP430x20x2

Port P1 (P1.0 to P1.2) pin functions, MSP430x20x2

PIN NAME (P1.X)	X	FUNCTION	CONTROL BITS / SIGNALS			
			P1DIR.x	P1SEL.x	ADC10AE.x	INCHx
P1.0/TACLK/ACLK/A0	0	P1.0† Input/Output	0/1	0	0	N/A
		Timer_A2.TACLK/INCLK	0	1	0	N/A
		ACLK	1	1	0	N/A
		A0 (see Note 3)	X	X	1	0
P1.1/TA0/A1	1	P1.1† Input/Output	0/1	0	0	N/A
		Timer_A2.CCI0A	0	1	0	N/A
		Timer_A2.TA0	1	1	0	N/A
		A1 (see Note 3)	X	X	1	1
P1.2/TA1/A2	2	P1.2† Input/Output	0/1	0	0	N/A
		Timer_A2.CCI1A	0	1	0	N/A
		Timer_A2.TA1	1	1	0	N/A
		A2 (see Note 3)	X	X	1	2

† Default after reset (PUC/POR)

NOTES: 1. N/A: Not available or not applicable.

2. X: Don't care.

3. Setting the ADC10AE.x bit disables the output driver as well as the input schmitt trigger to prevent parasitic cross currents when applying analog signals.

Port P1 (P1.0 to P1.2) pin schematics, MSP430x20x2

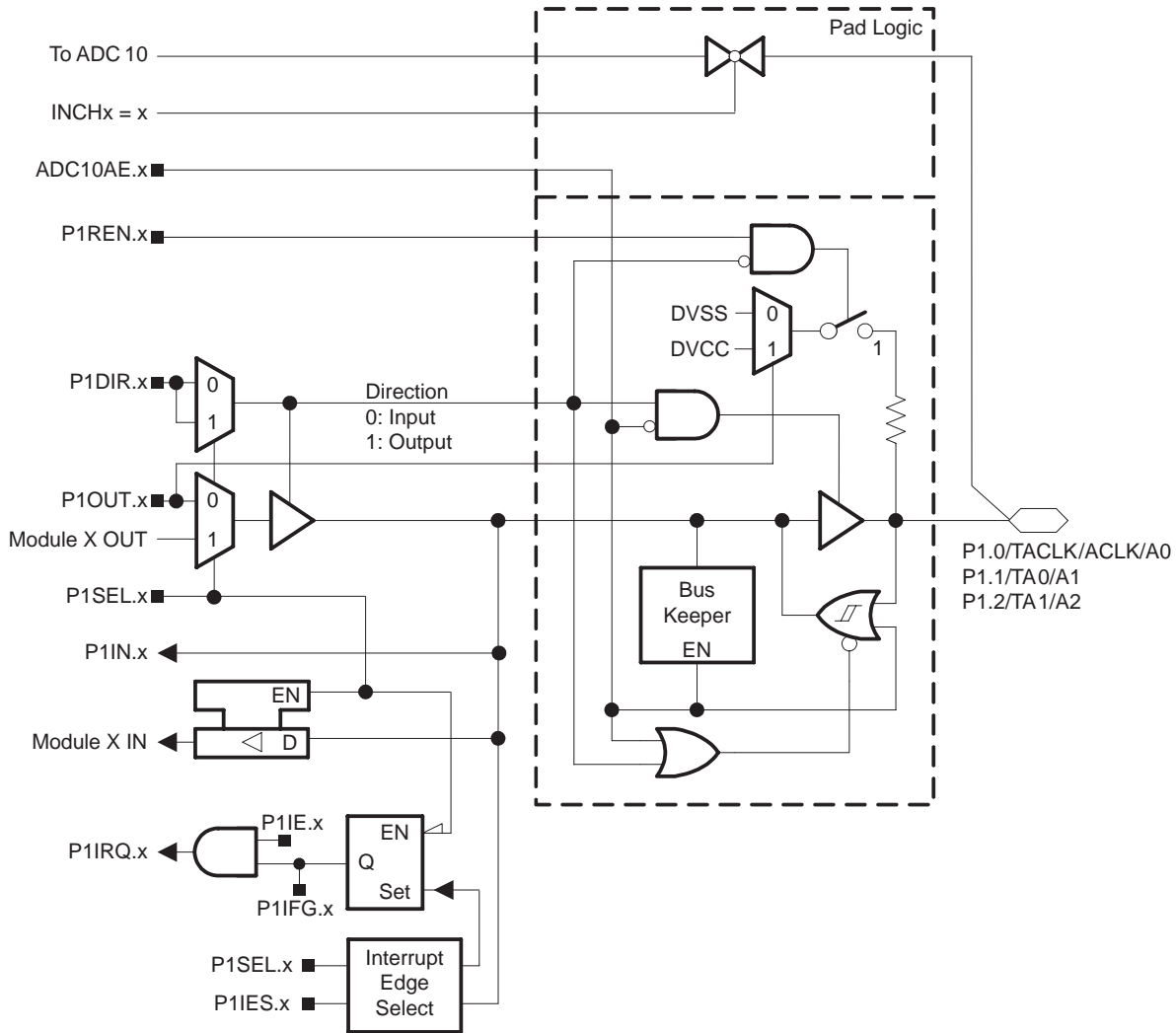

MSP430x20x1, MSP430x20x2, MSP430x20x3 MIXED SIGNAL MICROCONTROLLER

SLAS491A – AUGUST 2005 – REVISED OCTOBER 2005

Port P1 (P1.4 to P1.7) pin functions, MSP430x20x2

PIN NAME (P1.X)	X	FUNCTION	CONTROL BITS / SIGNALS					
			P1DIR.x	P1SEL.x	USIP.x	ADC10AE.x	INCHx	JTAG Mode
P1.4†/SMCLK/A4/ VREF+/VeREF+/ TCK	4	P1.4† Input/Output	0/1	0	N/A	0	N/A	0
		N/A	0	1		0	N/A	0
		SMCLK	1	1		0	N/A	0
		A4 (see Note 3)	X	X		1	4	0
		VREF+/VeREF+ (see Notes 3, 4)	X	X		1	N/A	0
		TCK (see Note 5)	X	X		X	X	1
P1.5/TA0/SCLK/A5/ TMS	5	P1.5† Input/Output	0/1	0	X	0	N/A	0
		N/A	0	1	X	0	N/A	0
		Timer_A2.TA0	1	1	X	0	N/A	0
		SCLK	X	X	1	0	N/A	0
		A5 (see Note 3)	X	X	X	1	5	0
		TMS (see Note 5)	X	X	X	X	X	1
P1.6/TA1/SDO/SCL/A6/ TDI	6	P1.6† Input/Output	0/1	0	X	0	N/A	0
		Timer_A2.CCI1B	0	1	X	0	N/A	0
		Timer_A2.TA1	1	1	X	0	N/A	0
		SDO (SPI) / SCL (I2C)	X	X	1	0	N/A	0
		A6 (see Note 3)	X	X	X	1	6	0
		TDI (see Note 5)	X	X	X	X	X	1
P1.7/SDI/SDA/A7/ TDO/TDI	7	P1.7† Input/Output	0/1	0	X	0	N/A	0
		N/A	0	1	X	0	N/A	0
		DVSS	1	1	X	0	N/A	0
		SDI (SPI) / SDA (I2C)	X	X	1	0	N/A	0
		A7 (see Note 3)	X	X	X	1	7	0
		TDO/TDI (see Notes 5, 6)	X	X	X	X	X	1

† Default after reset (PUC/POR)

- NOTES:
1. N/A: Not available or not applicable.
 2. X: Don't care.
 3. Setting the ADC10AE.x bit disables the output driver as well as the input schmitt trigger to prevent parasitic cross currents when applying analog signals.
 4. The reference voltage is output if bit REFOUT in register ADC10CTL0 is set. An applied voltage is used as positive reference if bits SREF0/1 in register ADC10CTL0 are set to 10 or 11.
 5. In JTAG mode the internal pull-up/down resistors are disabled.
 6. Function controlled by JTAG

Port P1 (P1.5) pin schematics, MSP430x20x2

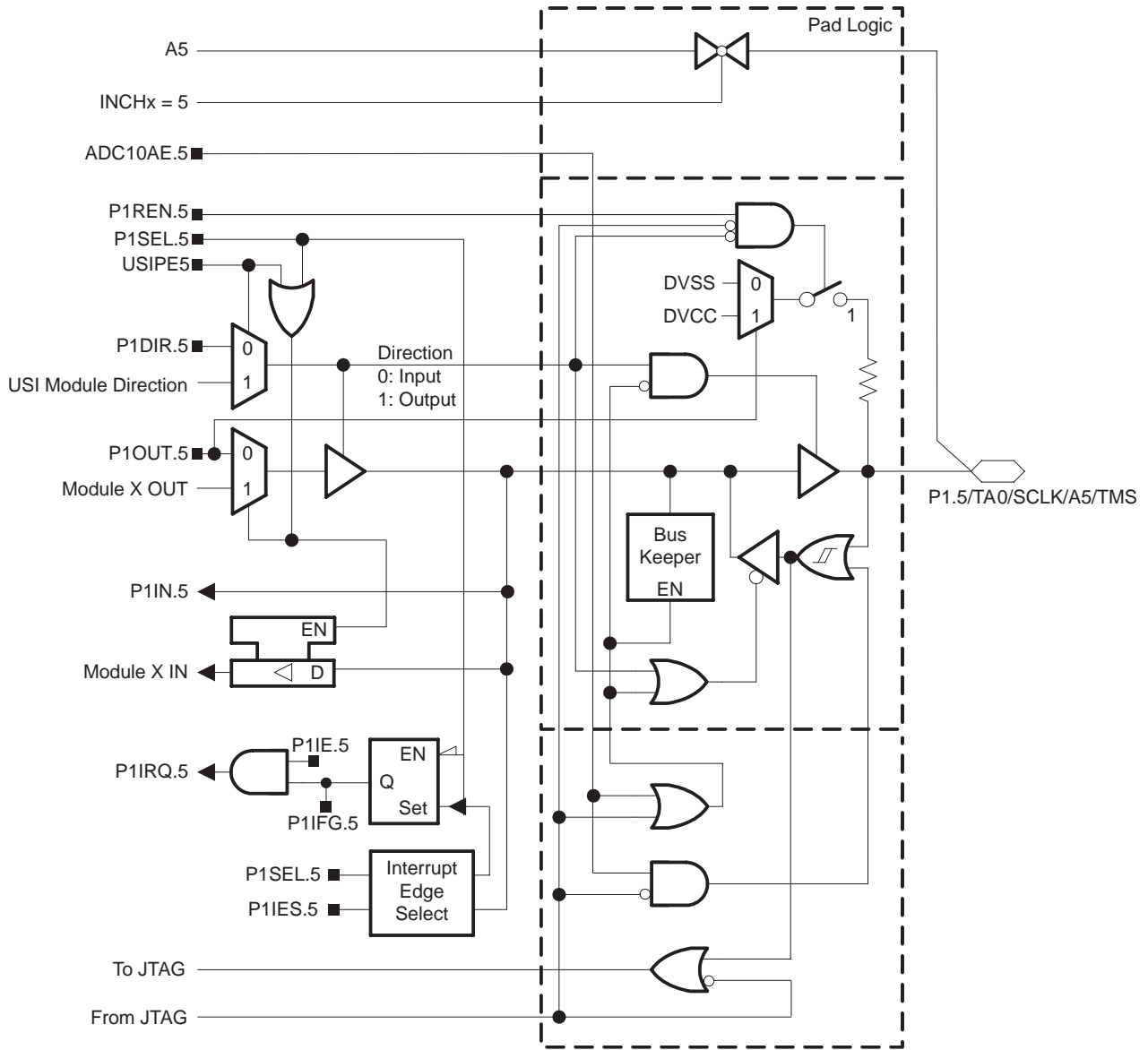

MSP430x20x1, MSP430x20x2, MSP430x20x3 MIXED SIGNAL MICROCONTROLLER

SLAS491A – AUGUST 2005 – REVISED OCTOBER 2005

Port P1 (P1.6) pin schematics, MSP430x20x2

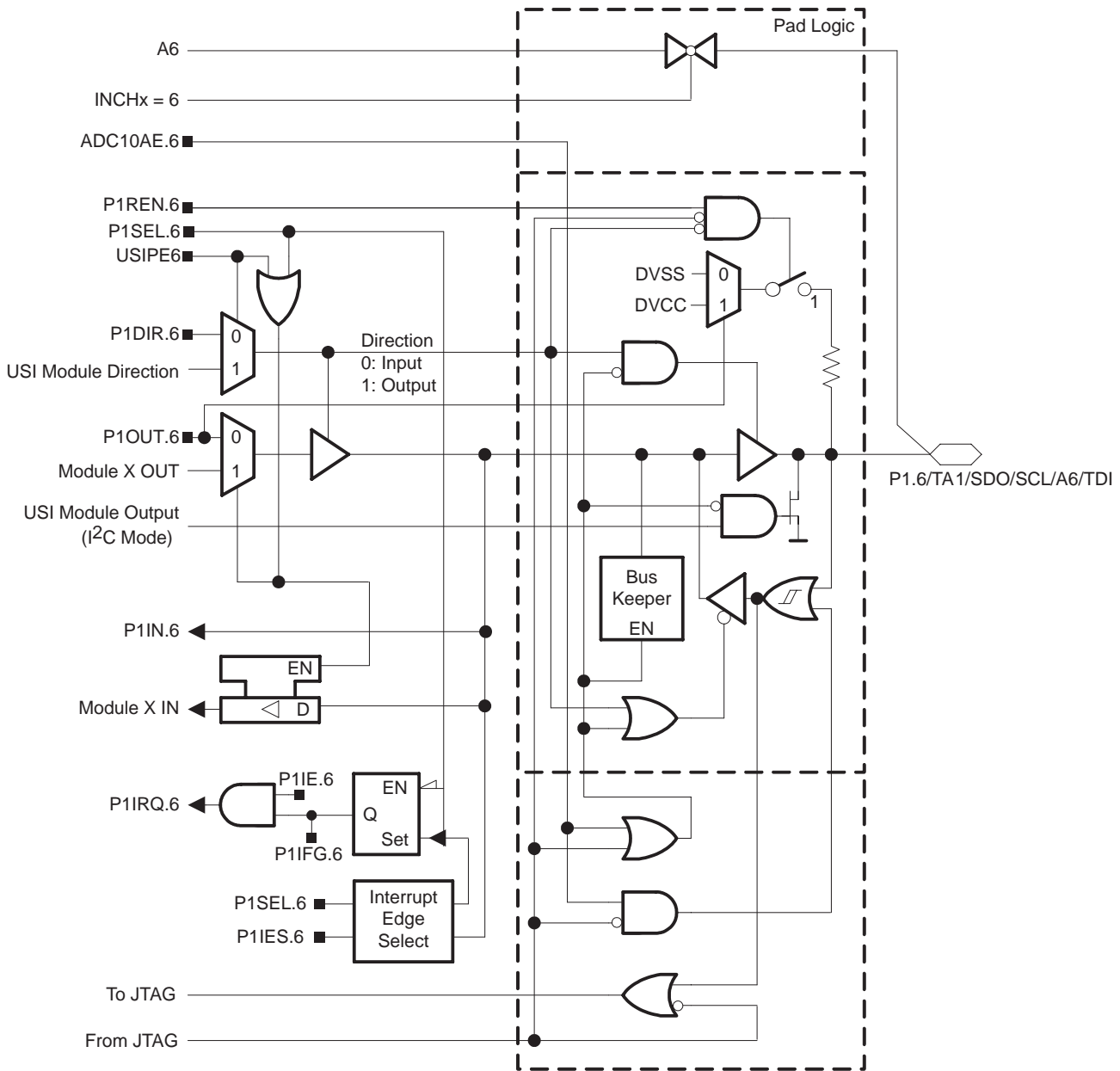

Port P1 (P1.7) pin schematics, MSP430x20x2

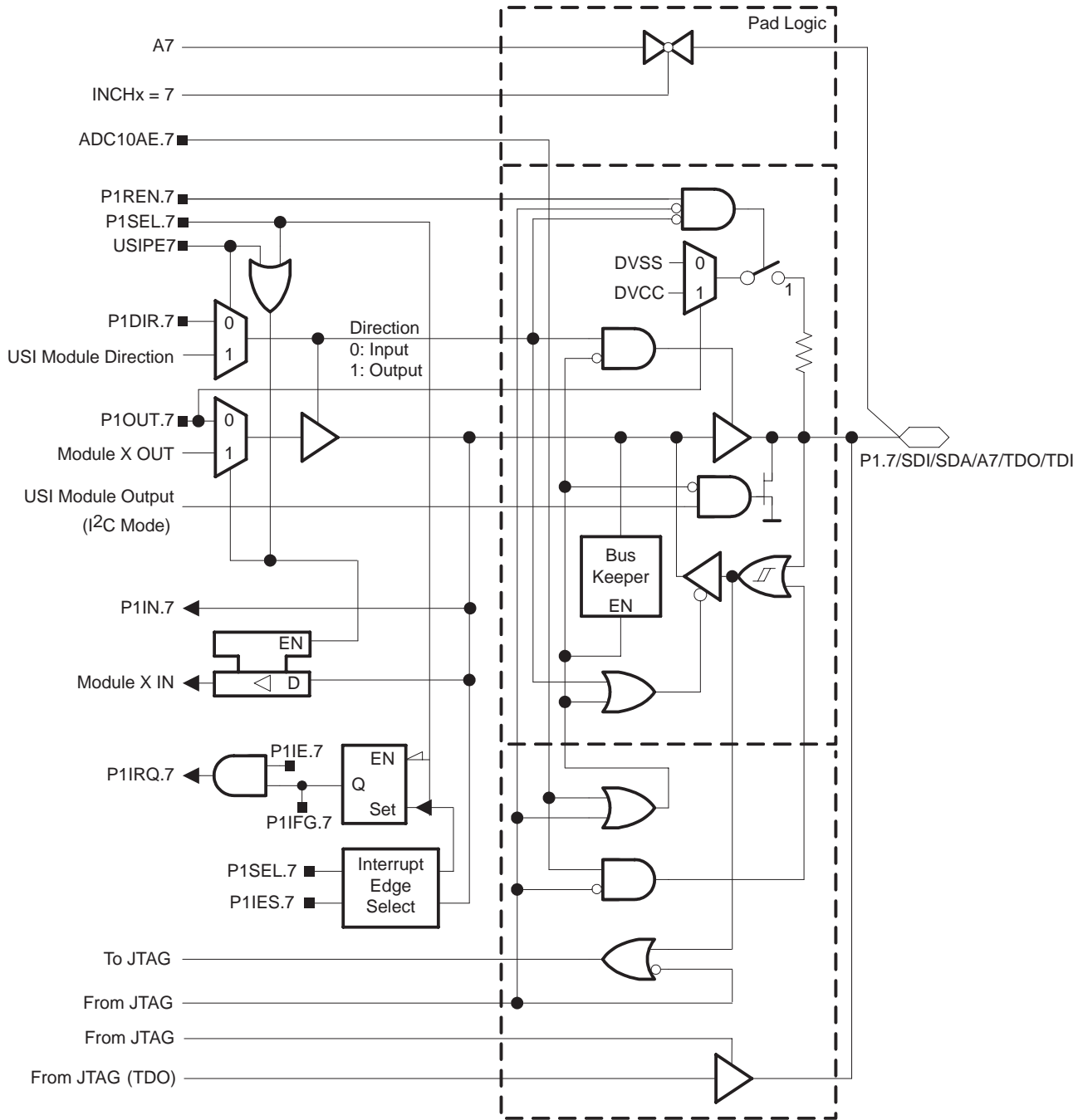

MSP430x20x1, MSP430x20x2, MSP430x20x3 MIXED SIGNAL MICROCONTROLLER

SLAS491A – AUGUST 2005 – REVISED OCTOBER 2005

Port P2 (P2.6) pin schematics, MSP430x20x2

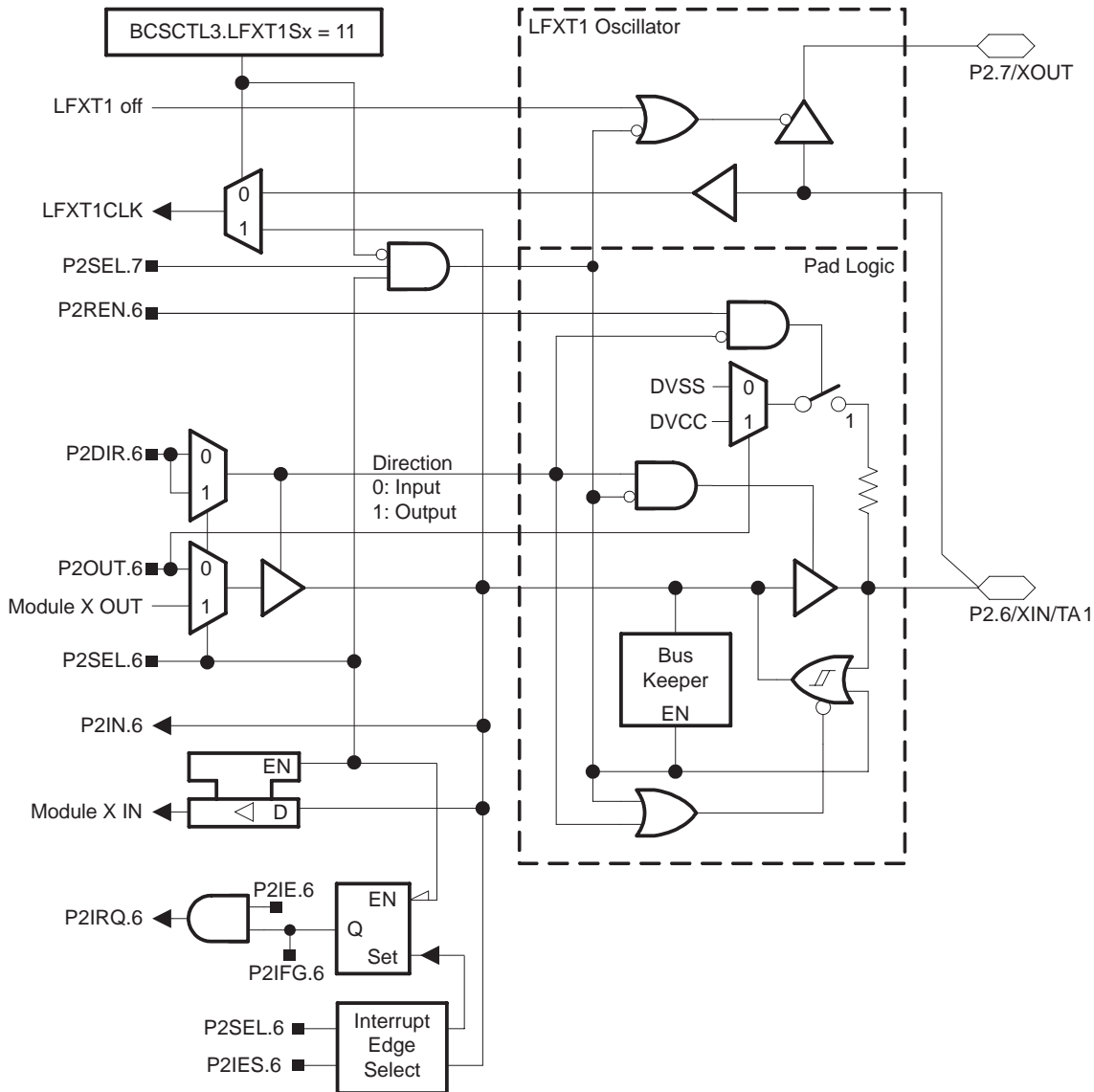

Port P2 (P2.6) pin functions, MSP430x20x2

PIN NAME (P2.X)	X	FUNCTION	CONTROL BITS / SIGNALS	
			P2DIR.x	P2SEL.x
P2.6/XIN/TA1	6	P2.6 Input/Output	0/1	0
		XIN† (see Note 3)	0	1
		Timer_A2.TA1	1	1

† Default after reset (PUC/POR)

NOTES: 1. N/A: Not available or not applicable.

2. X: Don't care.

3. XIN is used as digital clock input if the bits LFXT1Sx in register BCCTL3 are set to 11.

Port P2 (P2.7) pin schematics, MSP430x20x2

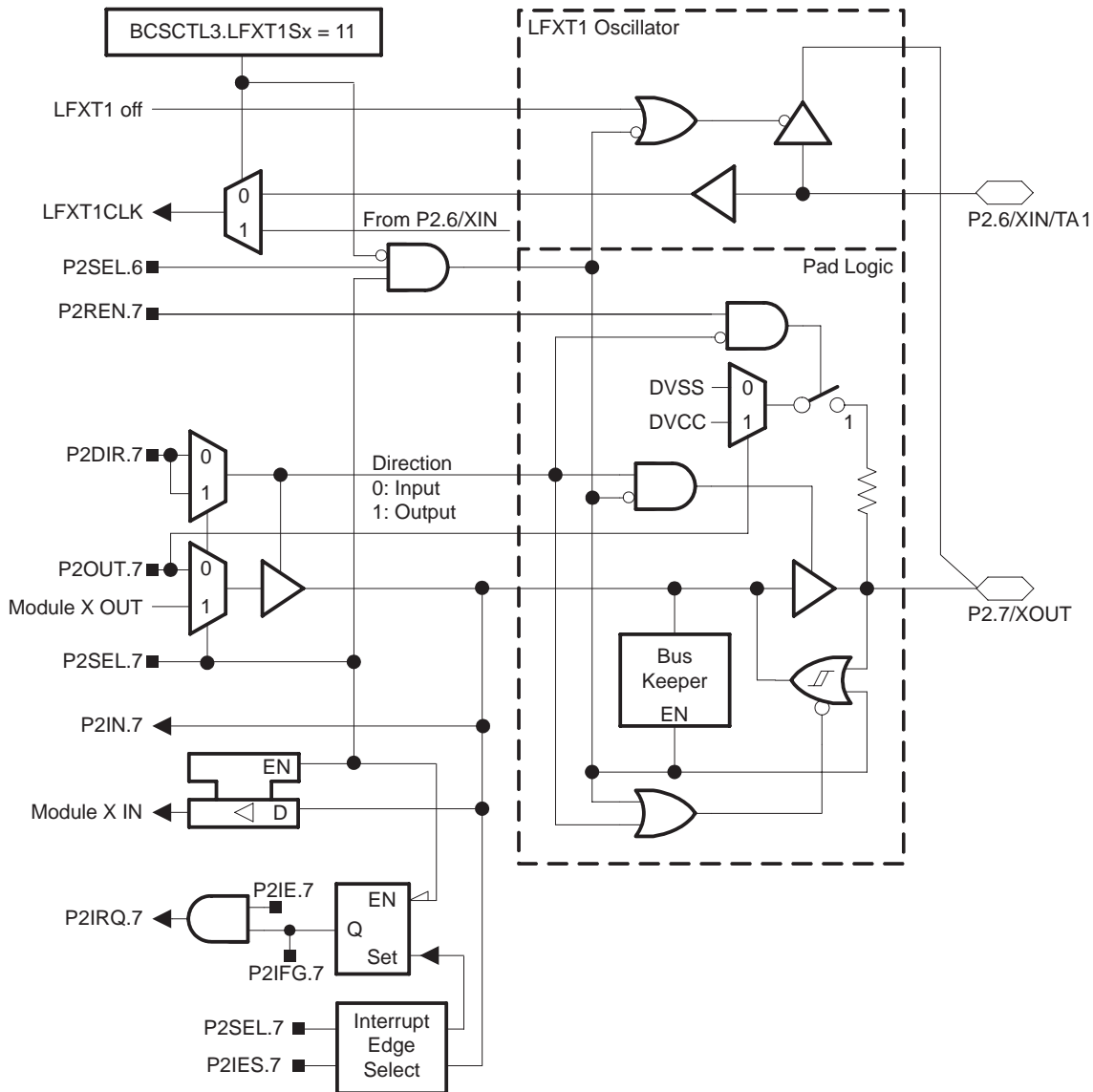

Port P2 (P2.7) pin functions, MSP430x20x2

PIN NAME (P2.X)	X	FUNCTION	CONTROL BITS / SIGNALS	
			P2DIR.x	P2SEL.x
P2.7/XOUT	7	P2.7 Input/Output	0/1	0
		DVSS	0	1
		XOUT† (see Note 3)	1	1

† Default after reset (PUC/POR)

NOTES: 1. N/A: Not available or not applicable.

2. X: Don't care.

3. If the pin P2.7/XOUT is used as an input a current can flow until P2SEL.7 is cleared due to the oscillator output driver connection to this pin after reset.

MSP430x20x1, MSP430x20x2, MSP430x20x3 MIXED SIGNAL MICROCONTROLLER

SLAS491A – AUGUST 2005 – REVISED OCTOBER 2005

APPLICATION INFORMATION, MSP430x20x3

Port P1 (P1.0 to P1.3) pin functions, MSP430x20x3

PIN NAME (P1.X)	X	FUNCTION	CONTROL BITS / SIGNALS			
			P1DIR.x	P1SEL.x	SD16AE.x	INCHx
P1.0/TACLK/ACLK/A0+	0	P1.0† Input/Output	0/1	0	0	N/A
		Timer_A2.TACLK/INCLK	0	1	0	N/A
		ACLK	1	1	0	N/A
		A0+ (see Note 3)	X	X	1	0
P1.1/TA0/A0–/A4+	1	P1.1† Input/Output	0/1	0	0	N/A
		Timer_A2.CCI0A	0	1	0	N/A
		Timer_A2.TA0	1	1	0	N/A
		A0– (see Notes 3, 4)	X	X	1	0
		A4+ (see Note 3)	X	X	1	4
P1.2/TA1/A1+/A4–	2	P1.2† Input/Output	0/1	0	0	N/A
		Timer_A2.CCI1A	0	1	0	N/A
		Timer_A2.TA1	1	1	0	N/A
		A1+ (see Note 3)	X	X	1	1
		A4– (see Notes 3, 4)	X	X	1	4
P1.3/VREF/A1–	3	P1.3† Input/Output	0/1	0	0	N/A
		VREF	X	1	0	N/A
		A1– (see Notes 3, 4)	X	X	1	1

† Default after reset (PUC/POR)

NOTES: 1. N/A: Not available or not applicable.

2. X: Don't care.

3. Setting the SD16AE.x bit disables the output driver as well as the input schmitt trigger to prevent parasitic cross currents when applying analog signals.

4. With SD16AE.x = 0 the negative inputs are connected to VSS if the corresponding input is selected.

Port P1 (P1.0) pin schematics, MSP430x20x3

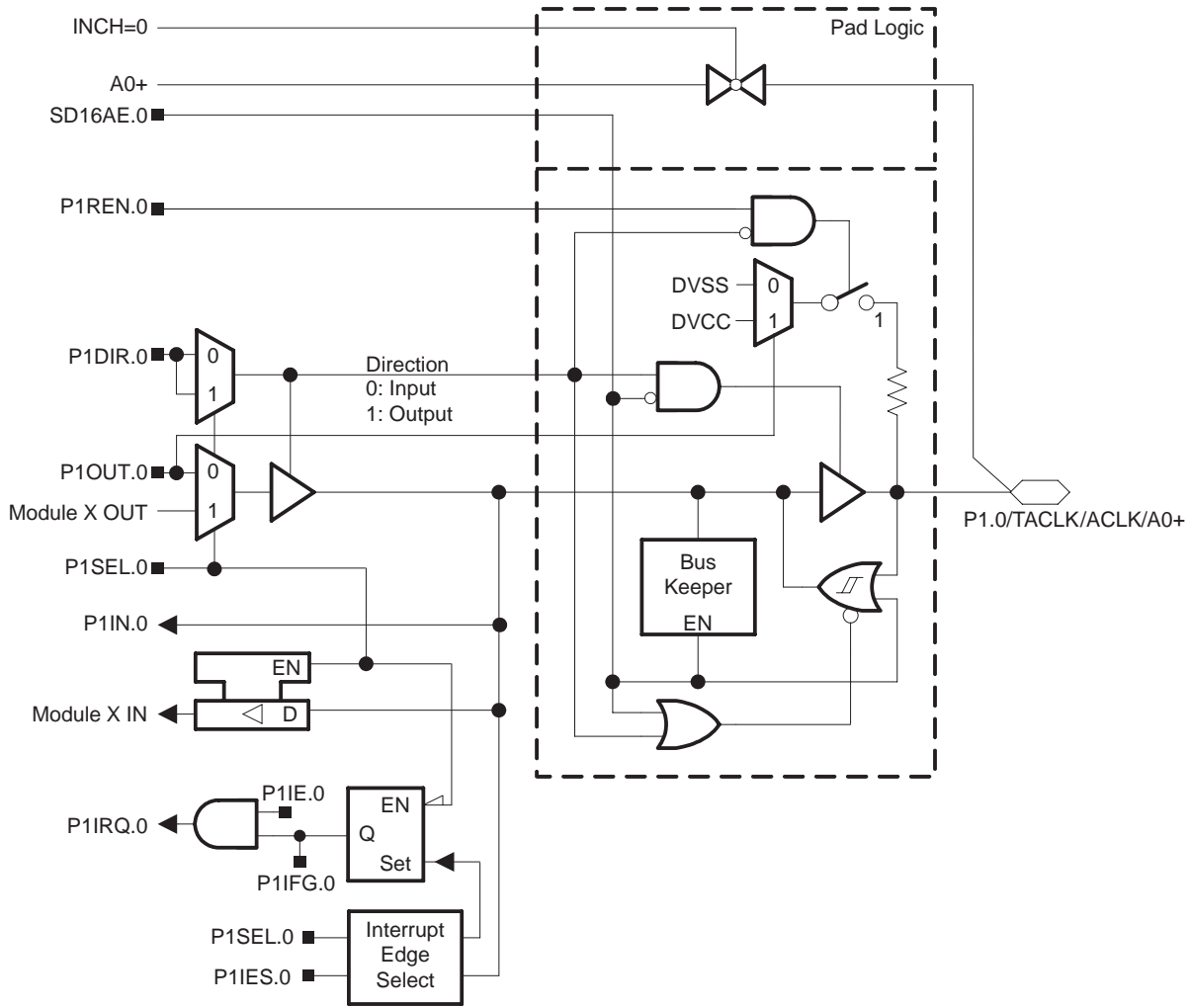

MSP430x20x1, MSP430x20x2, MSP430x20x3 MIXED SIGNAL MICROCONTROLLER

SLAS491A – AUGUST 2005 – REVISED OCTOBER 2005

Port P1 (P1.1) pin schematics, MSP430x20x3

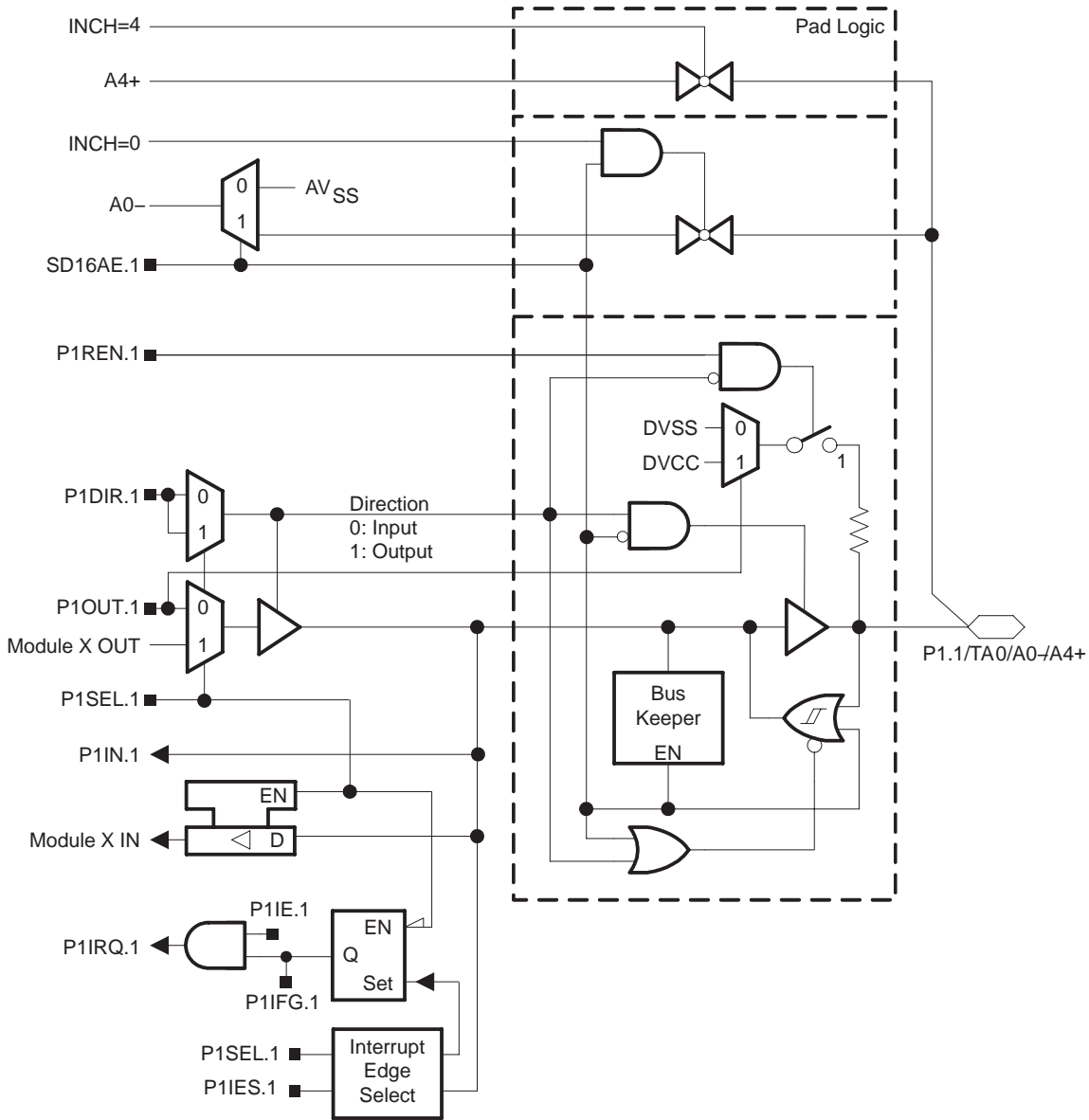

Port P1 (P1.2) pin schematics, MSP430x20x3

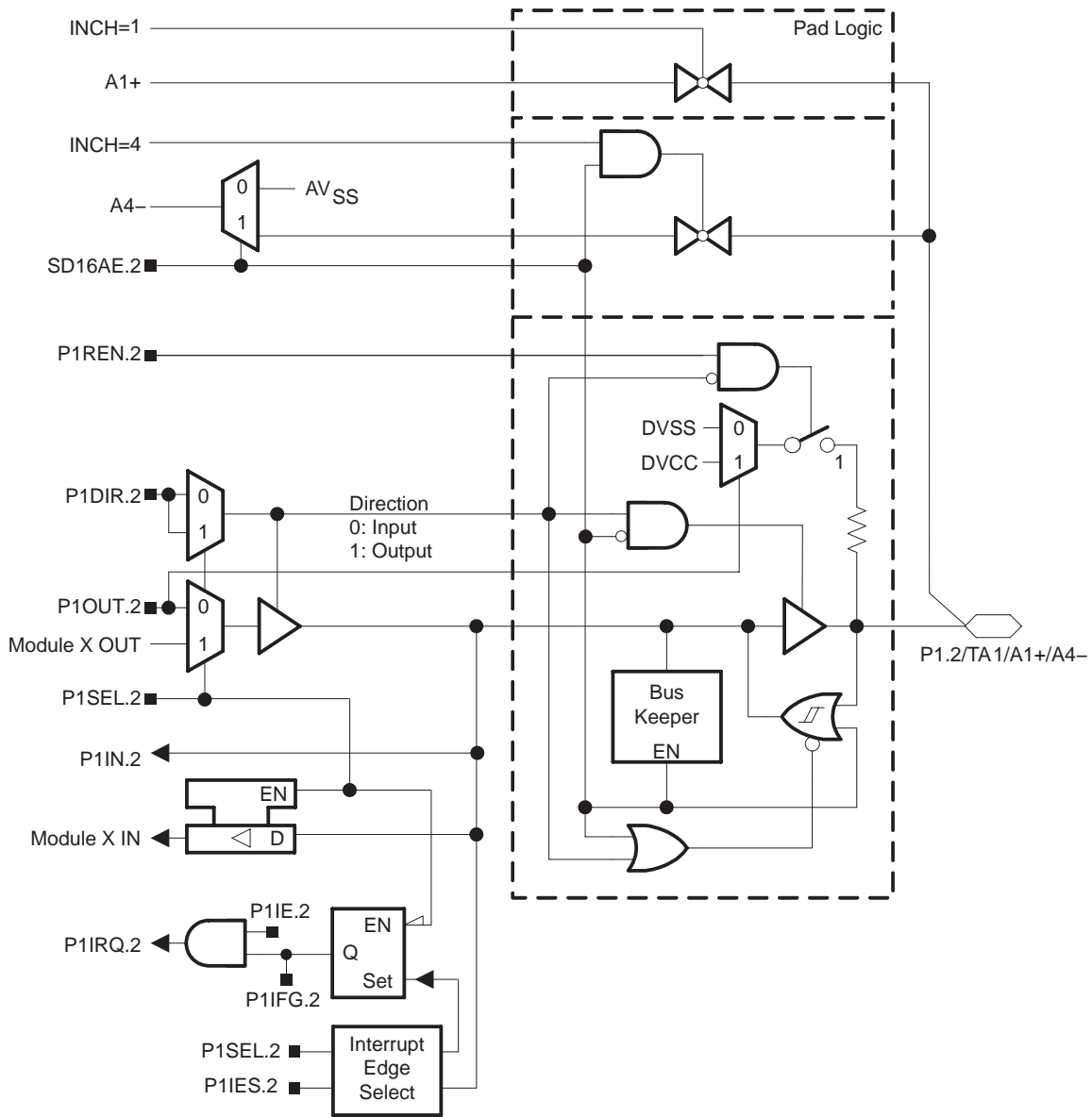

MSP430x20x1, MSP430x20x2, MSP430x20x3 MIXED SIGNAL MICROCONTROLLER

SLAS491A – AUGUST 2005 – REVISED OCTOBER 2005

Port P1 (P1.4 to P1.7) pin functions, MSP430x20x3

PIN NAME (P1.X)	X	FUNCTION	CONTROL BITS / SIGNALS					
			P1DIR.x	P1SEL.x	USIP.x	SD16AE.x	INCHx	JTAG Mode
P1.4/SMCLK/A2+/ TCK	4	P1.4† Input/Output	0/1	0	N/A	0	N/A	0
		N/A	0	1	N/A	0	N/A	0
		SMCLK	1	1	N/A	0	N/A	0
		A2+ (see Note 3)	X	X	N/A	1	2	0
		TCK (see Note 5)	X	X	N/A	X	X	1
P1.5/TA0/SCLK/A2-/ TMS	5	P1.5† Input/Output	0/1	0	X	0	N/A	0
		N/A	0	1	X	0	N/A	0
		Timer_A2.TA0	1	1	X	0	N/A	0
		SCLK	X	X	1	0	N/A	0
		A2- (see Notes 3, 4)	X	X	X	1	2	0
TMS (see Note 5)	X	X	X	X	X	1		
P1.6/TA1/SDO/SCL/A3+/ TDI	6	P1.6† Input/Output	0/1	0	X	0	N/A	0
		Timer_A2.CC1B	0	1	X	0	N/A	0
		Timer_A2.TA1	1	1	X	0	N/A	0
		SDO (SPI) / SCL (I2C)	X	X	1	0	N/A	0
		A3+ (see Note 3)	X	X	X	1	3	0
TDI (see Note 5)	X	X	X	X	X	1		
P1.7/SDI/SDA/A3-/ TDO/TDI	7	P1.7† Input/Output	0/1	0	X	0	N/A	0
		N/A	0	1	X	0	N/A	0
		DVSS	1	1	X	0	N/A	0
		SDI (SPI) / SDA (I2C)	X	X	1	0	N/A	0
		A3- (see Notes 3, 4)	X	X	X	1	3	0
TDO/TDI (see Notes 5, 6)	X	X	X	X	X	1		

† Default after reset (PUC/POR)

- NOTES:
1. N/A: Not available or not applicable.
 2. X: Don't care.
 3. Setting the SD16AE.x bit disables the output driver as well as the input schmitt trigger to prevent parasitic cross currents when applying analog signals.
 4. With SD16AE.x = 0 the negative inputs are connected to VSS if the corresponding input is selected.
 5. In JTAG mode the internal pull-up/down resistors are disabled.
 6. Function controlled by JTAG

MSP430x20x1, MSP430x20x2, MSP430x20x3 MIXED SIGNAL MICROCONTROLLER

SLAS491A – AUGUST 2005 – REVISED OCTOBER 2005

Port P1 (P1.4) pin schematics, MSP430x20x3

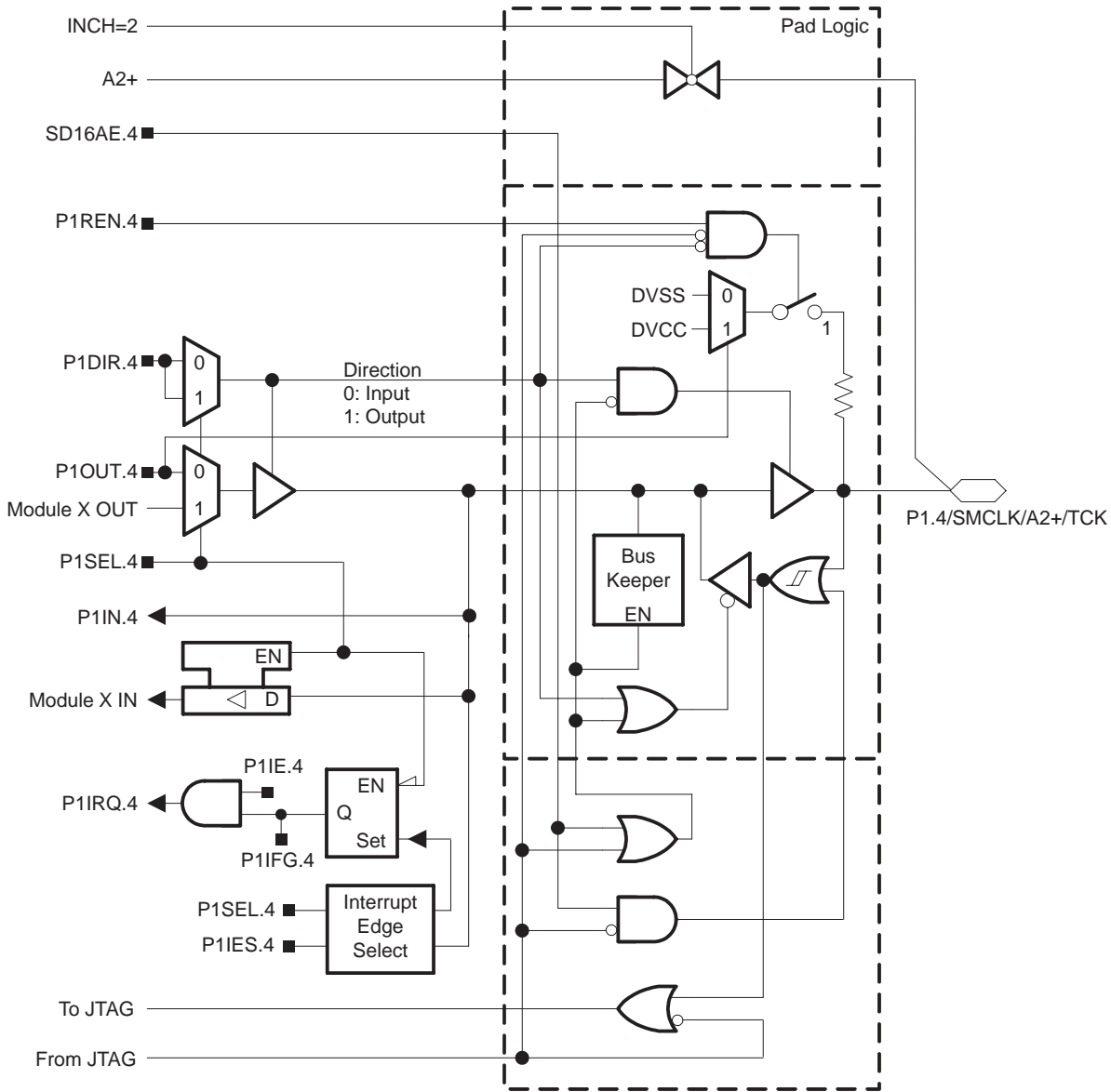

Port P1 (P1.5) pin schematics, MSP430x20x3

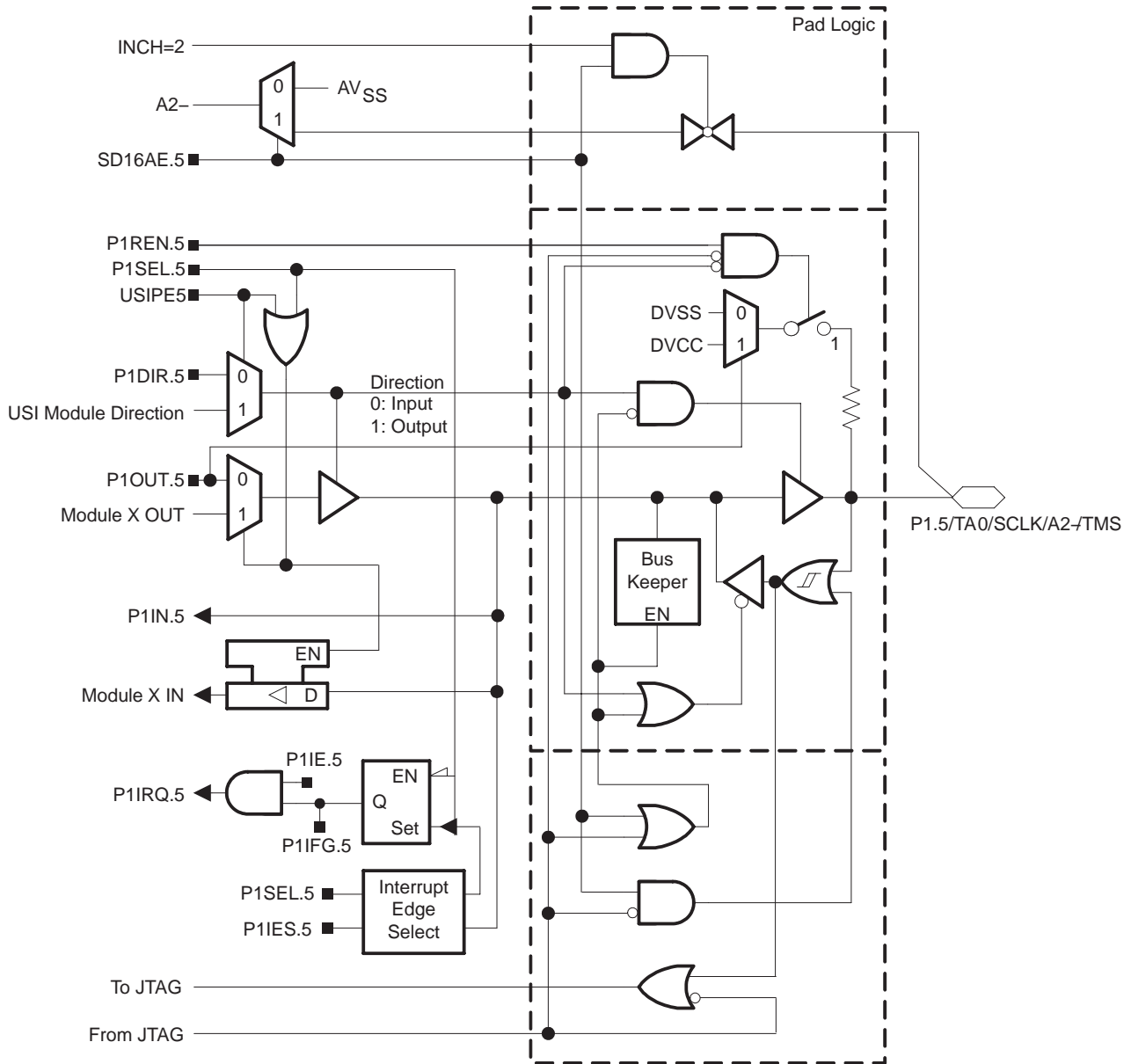

MSP430x20x1, MSP430x20x2, MSP430x20x3 MIXED SIGNAL MICROCONTROLLER

SLAS491A – AUGUST 2005 – REVISED OCTOBER 2005

Port P1 (P1.6) pin schematics, MSP430x20x3

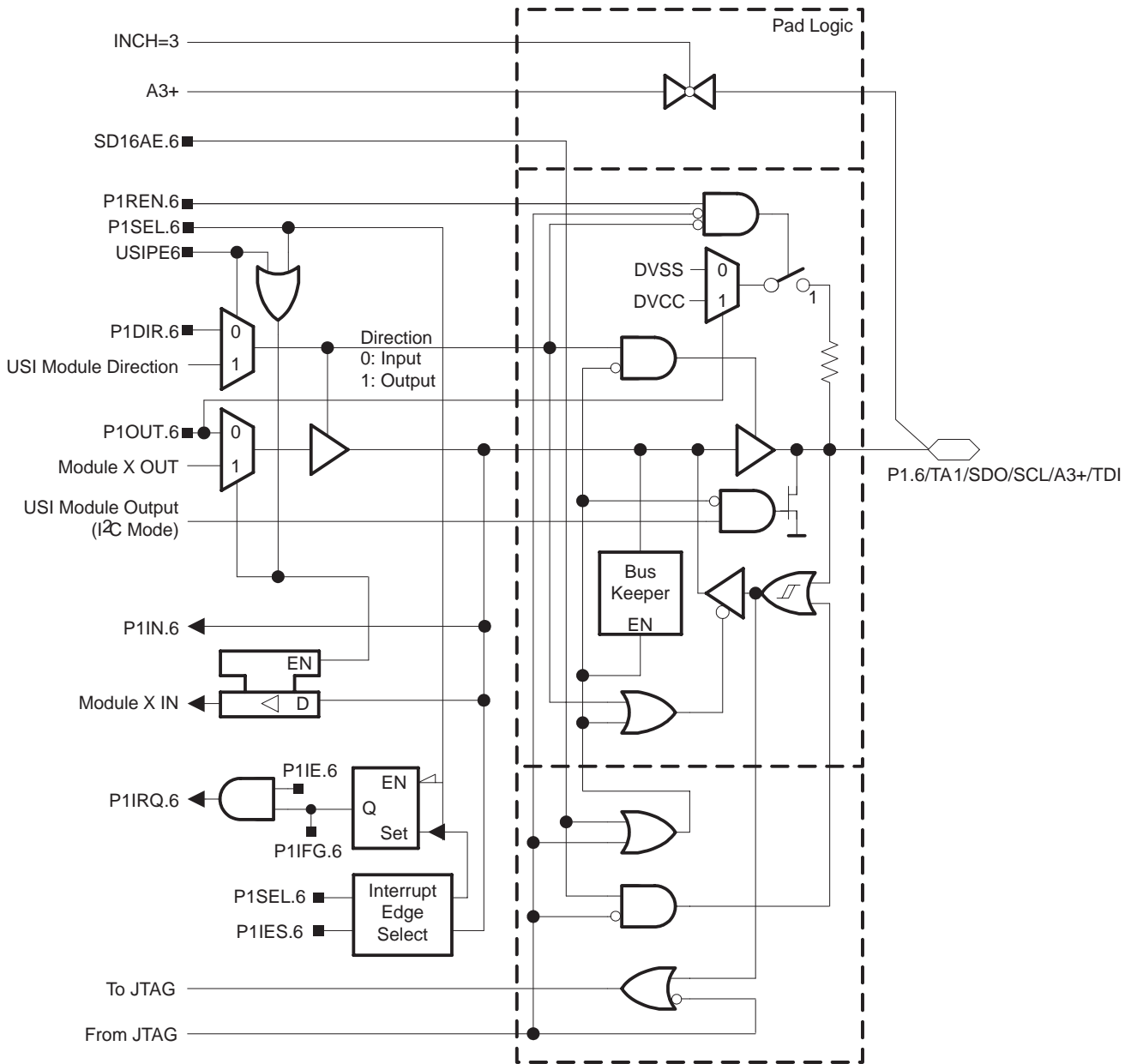

Port P1 (P1.7) pin schematics, MSP430x20x3

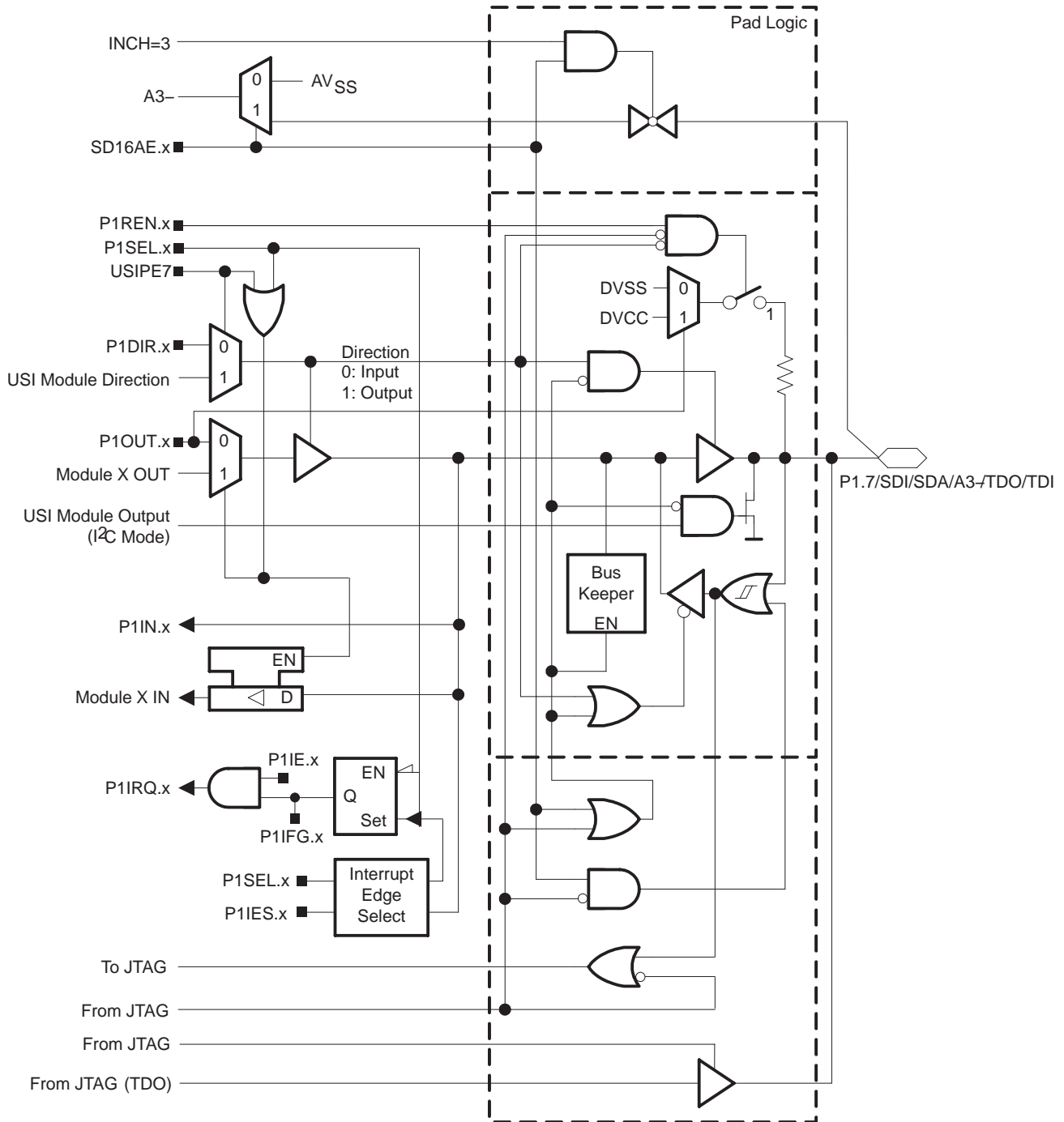

MSP430x20x1, MSP430x20x2, MSP430x20x3 MIXED SIGNAL MICROCONTROLLER

SLAS491A – AUGUST 2005 – REVISED OCTOBER 2005

Port P2 (P2.6) pin schematics, MSP430x20x3

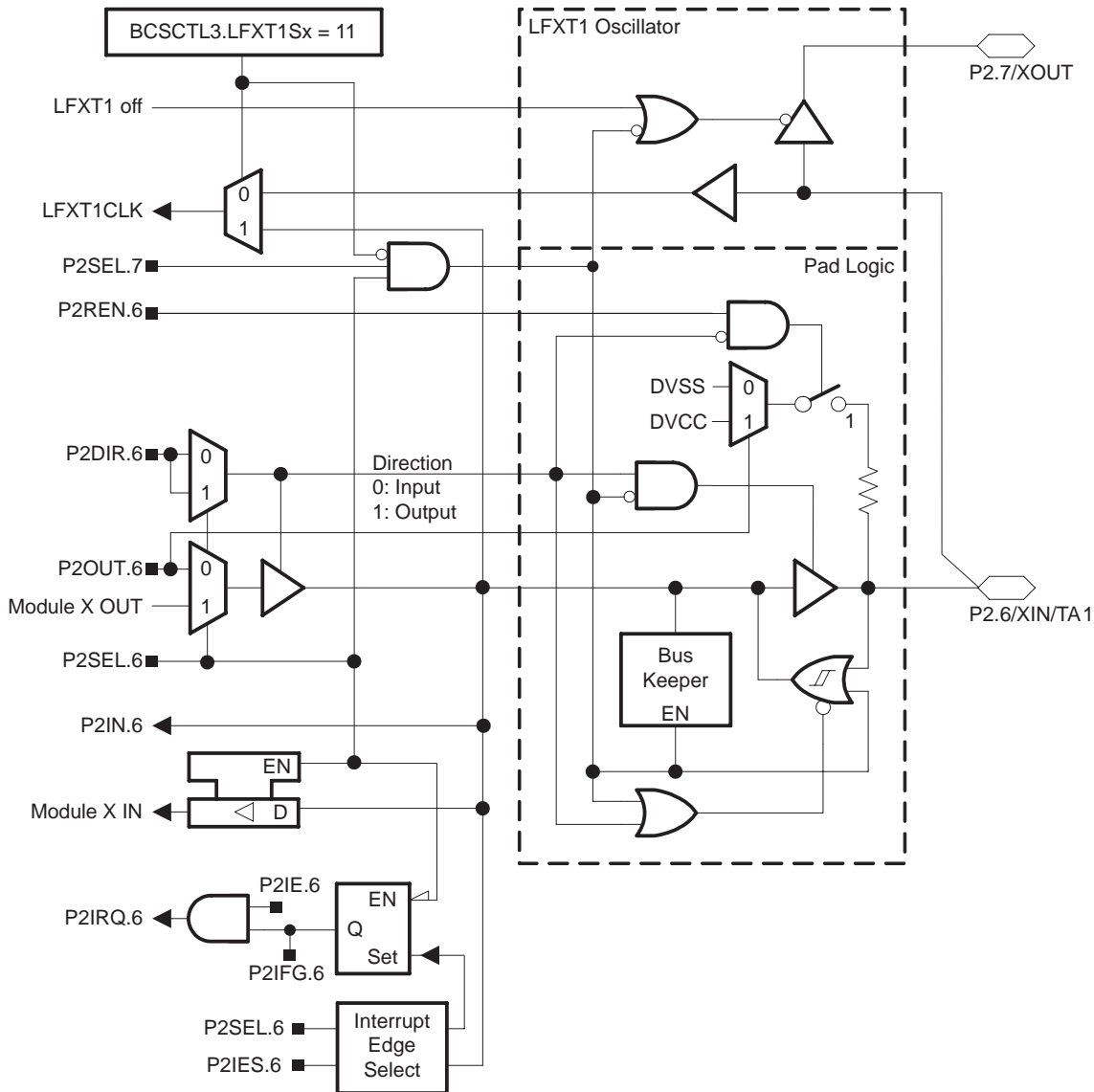

Port P2 (P2.6) pin functions, MSP430x20x3

PIN NAME (P2.X)	X	FUNCTION	CONTROL BITS / SIGNALS	
			P2DIR.x	P2SEL.x
P2.6/XIN/TA1	6	P2.6 Input/Output	0/1	0
		XIN† (see Note 3)	0	1
		Timer_A2.TA1	1	1

† Default after reset (PUC/POR)

NOTES: 1. N/A: Not available or not applicable.

2. X: Don't care.

3. XIN is used as digital clock input if the bits LFXT1Sx in register BCCTL3 are set to 11.

Port P2 (P2.7) pin schematics, MSP430x20x3

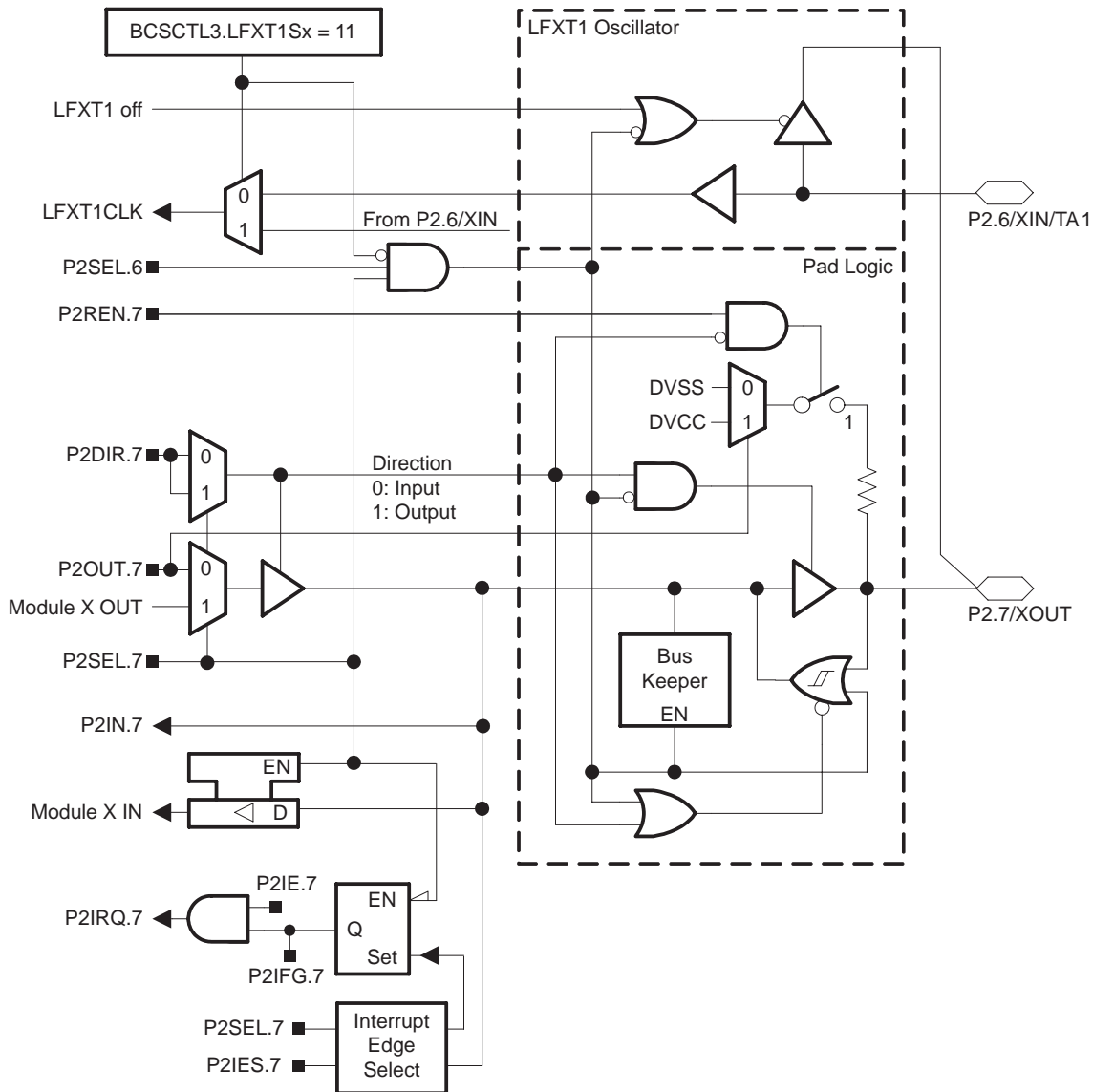

Port P2 (P2.7) pin functions, MSP430x20x3

PIN NAME (P2.X)	X	FUNCTION	CONTROL BITS / SIGNALS	
			P2DIR.x	P2SEL.x
P2.7/XOUT	7	P2.7 Input/Output	0/1	0
		DVSS	0	1
		XOUT† (see Note 3)	1	1

† Default after reset (PUC/POR)

NOTES: 1. N/A: Not available or not applicable.

2. X: Don't care.

3. If the pin P2.7/XOUT is used as an input a current can flow until P2SEL.7 is cleared due to the oscillator output driver connection to this pin after reset.

MSP430x20x1, MSP430x20x2, MSP430x20x3 MIXED SIGNAL MICROCONTROLLER

SLAS491A – AUGUST 2005 – REVISED OCTOBER 2005

Data Sheet Revision History

Literature Number	Summary
SLAS491	Preliminary PRODUCT PREVIEW datasheet release.
SLAS491A	MSP430x20x3 production datasheet release. Updated specification and added characterization graphs.

NOTE: The referring page and figure numbers are referred to the respective document revision.

PW (R-PDSO-G**)

PLASTIC SMALL-OUTLINE PACKAGE

14 PINS SHOWN



4040064/F 01/97

- NOTES: A. All linear dimensions are in millimeters.
 B. This drawing is subject to change without notice.
 C. Body dimensions do not include mold flash or protrusion not to exceed 0,15.
 D. Falls within JEDEC MO-153

IMPORTANT NOTICE

Texas Instruments Incorporated and its subsidiaries (TI) reserve the right to make corrections, modifications, enhancements, improvements, and other changes to its products and services at any time and to discontinue any product or service without notice. Customers should obtain the latest relevant information before placing orders and should verify that such information is current and complete. All products are sold subject to TI's terms and conditions of sale supplied at the time of order acknowledgment.

TI warrants performance of its hardware products to the specifications applicable at the time of sale in accordance with TI's standard warranty. Testing and other quality control techniques are used to the extent TI deems necessary to support this warranty. Except where mandated by government requirements, testing of all parameters of each product is not necessarily performed.

TI assumes no liability for applications assistance or customer product design. Customers are responsible for their products and applications using TI components. To minimize the risks associated with customer products and applications, customers should provide adequate design and operating safeguards.

TI does not warrant or represent that any license, either express or implied, is granted under any TI patent right, copyright, mask work right, or other TI intellectual property right relating to any combination, machine, or process in which TI products or services are used. Information published by TI regarding third-party products or services does not constitute a license from TI to use such products or services or a warranty or endorsement thereof. Use of such information may require a license from a third party under the patents or other intellectual property of the third party, or a license from TI under the patents or other intellectual property of TI.

Reproduction of information in TI data books or data sheets is permissible only if reproduction is without alteration and is accompanied by all associated warranties, conditions, limitations, and notices. Reproduction of this information with alteration is an unfair and deceptive business practice. TI is not responsible or liable for such altered documentation.

Resale of TI products or services with statements different from or beyond the parameters stated by TI for that product or service voids all express and any implied warranties for the associated TI product or service and is an unfair and deceptive business practice. TI is not responsible or liable for any such statements.

Following are URLs where you can obtain information on other Texas Instruments products and application solutions:

Products		Applications	
Amplifiers	amplifier.ti.com	Audio	www.ti.com/audio
Data Converters	dataconverter.ti.com	Automotive	www.ti.com/automotive
DSP	dsp.ti.com	Broadband	www.ti.com/broadband
Interface	interface.ti.com	Digital Control	www.ti.com/digitalcontrol
Logic	logic.ti.com	Military	www.ti.com/military
Power Mgmt	power.ti.com	Optical Networking	www.ti.com/opticalnetwork
Microcontrollers	microcontroller.ti.com	Security	www.ti.com/security
		Telephony	www.ti.com/telephony
		Video & Imaging	www.ti.com/video
		Wireless	www.ti.com/wireless

Mailing Address: Texas Instruments
Post Office Box 655303 Dallas, Texas 75265