

DATA SHEET

PCF8593

Low power clock/calendar

Product specification
Supersedes data of July 1994
File under Integrated Circuits, IC12

1997 Mar 25

Low power clock/calendar

PCF8593

CONTENTS			
1	FEATURES	10	LIMITING VALUES
2	GENERAL DESCRIPTION	11	HANDLING
3	QUICK REFERENCE DATA	12	DC CHARACTERISTICS
4	ORDERING INFORMATION	13	AC CHARACTERISTICS
5	BLOCK DIAGRAM	14	APPLICATION INFORMATION
6	PINNING	14.1	Quartz frequency adjustment
7	FUNCTIONAL DESCRIPTION	14.1.1	Method 1: Fixed OSCI capacitor
7.1	Counter function modes	14.1.2	Method 2: OSCI Trimmer
7.2	Alarm function modes	14.1.3	Method 3: direct output
7.3	Control/status register	15	PACKAGE OUTLINES
7.4	Counter registers	16	SOLDERING
7.5	Alarm control register	16.1	Introduction
7.6	Alarm registers	16.2	DIP
7.7	Timer	16.2.1	Soldering by dipping or by wave
7.8	Event counter mode	16.2.2	Repairing soldered joints
7.9	Interrupt output	16.3	SO
7.10	Oscillator and divider	16.3.1	Reflow soldering
7.10.1	Designing	16.3.2	Wave soldering
7.11	Initialization (see Fig.12)	16.3.3	Repairing soldered joints
8	CHARACTERISTICS OF THE I ² C-BUS	17	DEFINITIONS
8.1	Bit transfer	18	LIFE SUPPORT APPLICATIONS
8.2	Start and stop conditions	19	PURCHASE OF PHILIPS I ² C COMPONENTS
8.3	System configuration		
8.4	Acknowledge		
9	I ² C-BUS PROTOCOL		
9.1	Addressing		
9.2	Clock/calendar READ/WRITE cycles		



Low power clock/calendar

PCF8593

1 FEATURES

- I²C-bus interface operating supply voltage: 2.5 to 6.0 V
- Clock operating supply voltage ($T_{amb} = 0$ to $+70$ °C): 1.0 to 6.0 V
- 8 bytes scratchpad RAM (when alarm not used)
- Data retention voltage: 1.0 to 6.0 V
- External $\overline{\text{RESET}}$ input resets I²C interface (only)
- Operating current ($f_{scl} = 0$ Hz, 32 kHz time base, $V_{DD} = 2.0$ V): typ. 1 μA
- Clock function with four year calendar
- Universal timer with alarm and overflow indication
- 24 or 12 hour format
- 32.768 kHz or 50 Hz time base
- Serial input/output bus (I²C-bus)
- Automatic word address incrementing
- Programmable alarm, timer and interrupt function
- Space-saving SO8 package available
- Slave address:
 - READ A3
 - WRITE A2.

2 GENERAL DESCRIPTION

The PCF8593 is a CMOS clock/calendar circuit, optimized for low power consumption. Addresses and data are transferred serially via the two-line bidirectional I²C-bus. The built-in word address register is incremented automatically after each written or read data byte. The built-in 32.768 kHz oscillator circuit and the first 8 bytes of RAM are used for the clock/calendar and counter functions. The next 8 bytes may be programmed as alarm registers or used as free RAM space.

3 QUICK REFERENCE DATA

SYMBOL	PARAMETER	CONDITIONS	MIN.	TYP.	MAX.	UNIT
V_{DD}	supply voltage operating mode	I ² C-bus active	2.5	–	6.0	V
		I ² C-bus inactive	1.0	–	6.0	V
I_{DD}	supply current operating mode	$f_{scl} = 100$ kHz	–	–	200	μA
I_{DD}	supply current clock mode	$f_{scl} = 0$ Hz; $V_{DD} = 5$ V	–	4.0	15.0	μA
		$f_{scl} = 0$ Hz; $V_{DD} = 2$ V	–	1.0	8.0	μA
T_{amb}	operating ambient temperature		–40	–	+85	°C
T_{stg}	storage temperature		–65	–	+150	°C

4 ORDERING INFORMATION

TYPE NUMBER	PACKAGE		
	NAME	DESCRIPTION	VERSION
PCF8593P	DIP8	plastic dual in-line package; 8 leads (300 mil)	SOT97-1
PCF8593T	SO8	plastic small outline package; 8 leads; body width 3.9 mm	SOT96-1

Low power clock/calendar

PCF8593

5 BLOCK DIAGRAM

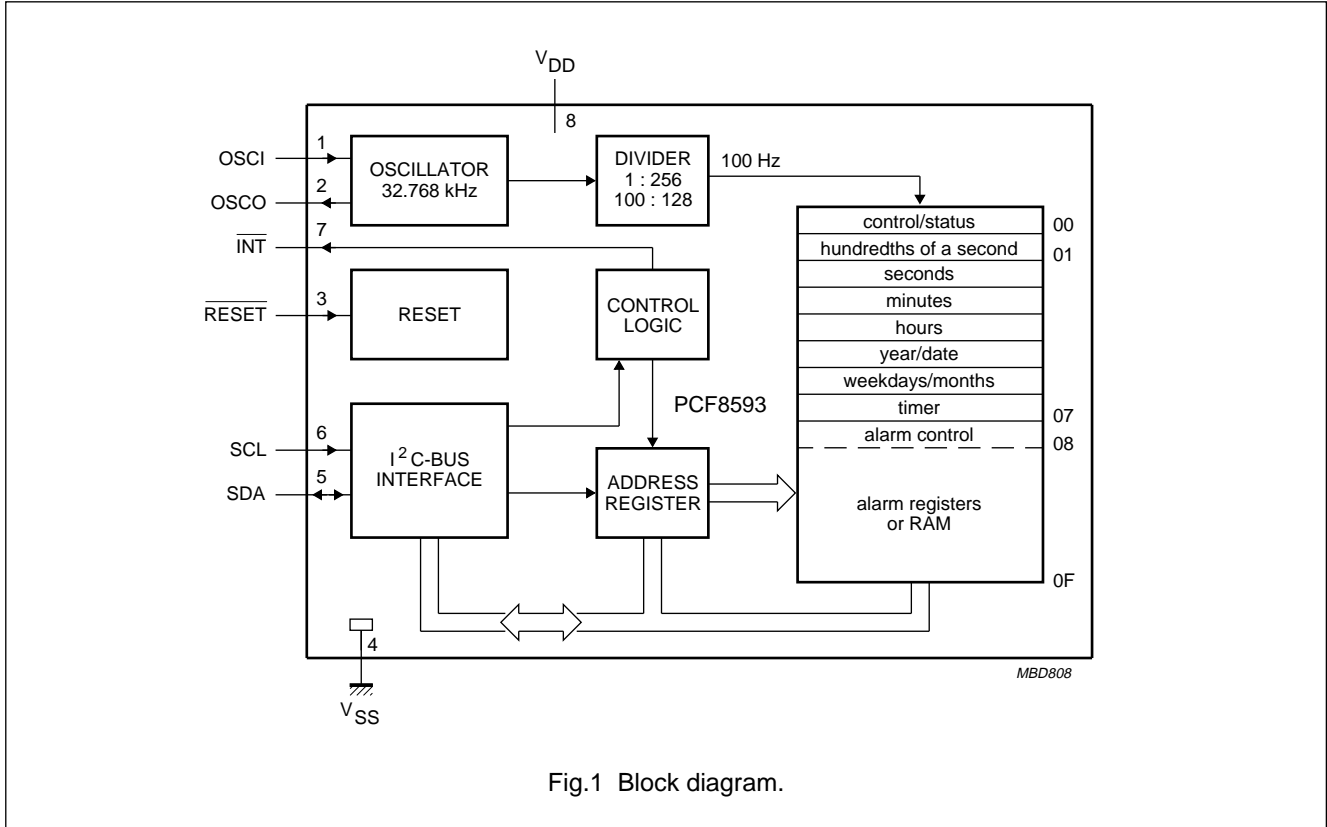

6 PINNING

SYMBOL	PIN	DESCRIPTION
OSCI	1	oscillator input, 50 Hz or event-pulse input
OSCO	2	oscillator output
RESET	3	reset input (active LOW)
V _{SS}	4	negative supply
SDA	5	serial data input/output
SCL	6	serial clock input
INT	7	open drain interrupt output (active LOW)
V _{DD}	8	positive supply

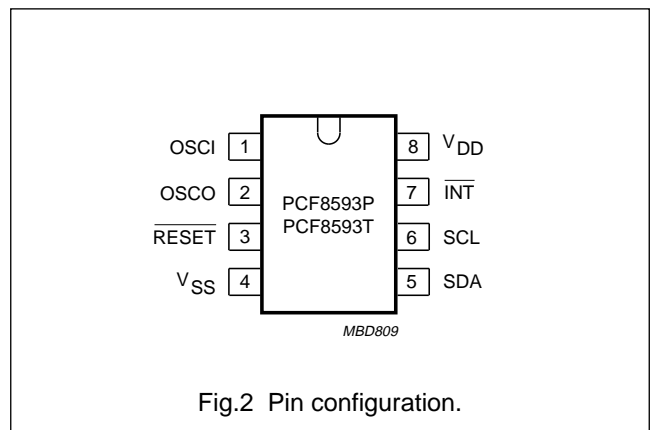

Low power clock/calendar

PCF8593

7 FUNCTIONAL DESCRIPTION

The PCF8593 contains sixteen 8-bit registers with an 8-bit auto-incrementing address register, an on-chip 32.768 kHz oscillator circuit, a frequency divider and a serial two-line bidirectional I²C-bus interface.

The first 8 registers (memory addresses 00 to 07) are designed as addressable 8-bit parallel registers. The first register (memory address 00) is used as a control/status register. The memory addresses 01 to 07 are used as counters for the clock function. The memory addresses 08 to 0F may be programmed as alarm registers or used as free RAM locations.

7.1 Counter function modes

When the control/status register is programmed, a 32.768 kHz clock mode, a 50 Hz clock mode or an event-counter mode can be selected.

In the clock modes the hundredths of a second, seconds, minutes, hours, date, month (four year calendar) and weekday are stored in a BCD format. The timer register stores up to 99 days. The event counter mode is used to count pulses applied to the oscillator input (OSCO left open-circuit). The event counter stores up to 6 digits of data.

When one of the counters is read (memory locations 01 to 07), the contents of all counters are strobed into capture latches at the beginning of a read cycle. Therefore, faulty reading of the count during a carry condition is prevented.

When a counter is written, other counters are not affected.

7.2 Alarm function modes

By setting the alarm enable bit of the control/status register the alarm control register (address 08) is activated.

By setting the alarm control register a dated alarm, a daily alarm, a weekday alarm or a timer alarm may be programmed. In the clock modes, the timer register (address 07) may be programmed to count hundredths of

a second, seconds, minutes, hours or days. Days are counted when an alarm is not programmed.

Whenever an alarm event occurs the alarm flag of the control/status register is set. A timer alarm event will set the alarm flag and an overflow condition of the timer will set the timer flag. The open-drain interrupt output is switched on (active LOW) when the alarm or timer flag is set (enabled). The flags remain set until directly reset by a write operation.

When the alarm is disabled (Bit 2 of control/status register = 0) the alarm registers at addresses 08 to 0F may be used as free RAM.

7.3 Control/status register

The control/status register is defined as the memory location 00 with free access for reading and writing via the I²C-bus. All functions and options are controlled by the contents of the control/status register (see Fig.3).

7.4 Counter registers

In the clock modes 24 h or 12 h format can be selected by setting the most significant bit of the hours counter register. The format of the hours counter is shown in Fig.5.

The year and date are packed into memory location 05 (see Fig 6). The weekdays and months are packed into memory location 06 (see Fig.7). When reading these memory locations the year and weekdays are masked out when the mask flag of the control/status register is set. This allows the user to read the date and month count directly.

In the event-counter mode events are stored in BCD format. D5 is the most significant and D0 the least significant digit. The divider is by-passed.

In the different modes the counter registers are programmed and arranged as shown in Fig.4. Counter cycles are listed in Table 1.

Low power clock/calendar

PCF8593

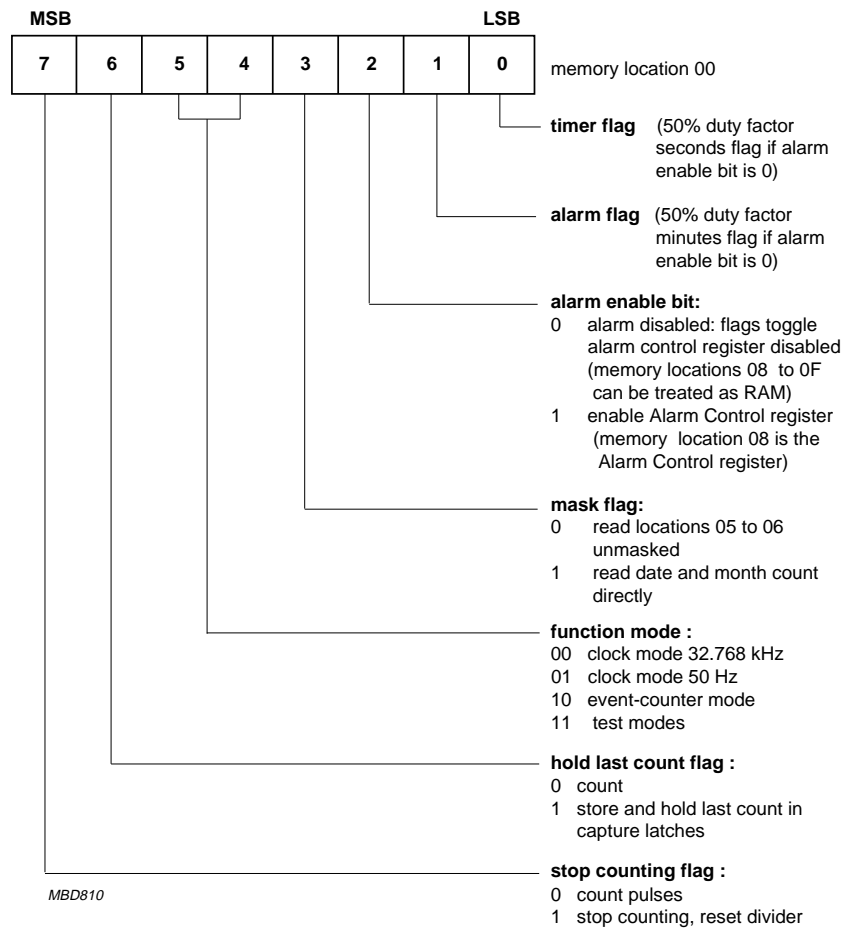
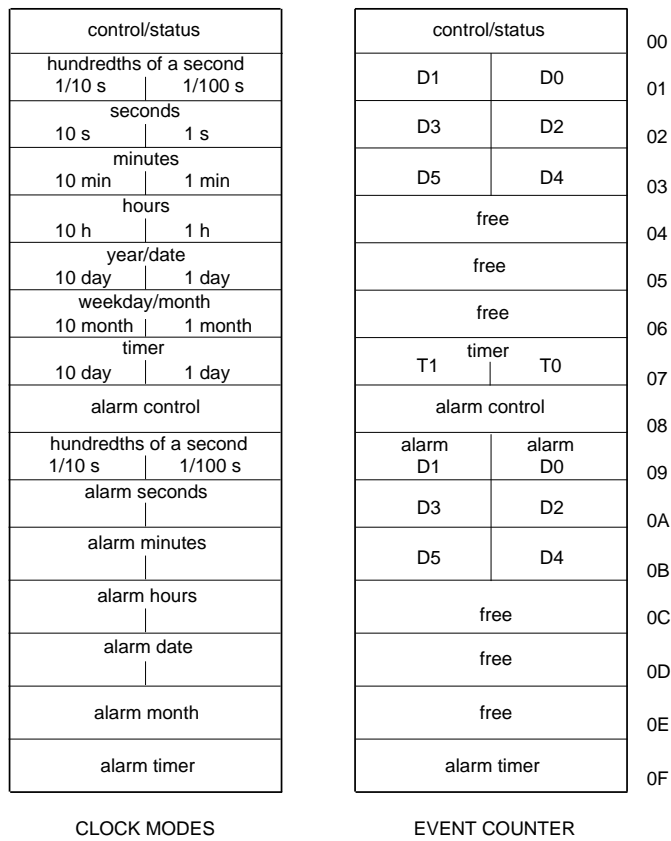

Fig.3 Control/status register.

Low power clock/calendar

PCF8593



MBD811

Fig.4 Register arrangement.

Low power clock/calendar

PCF8593

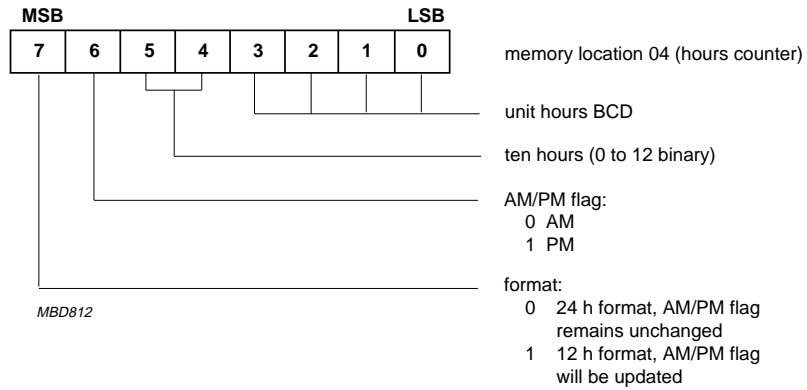

Fig.5 Format of the hours counter.

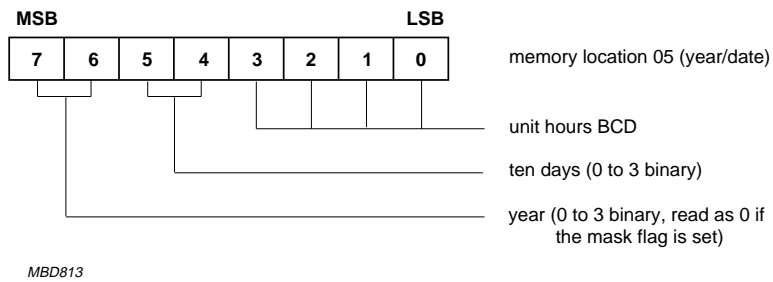

Fig.6 Format of the year/date counter.

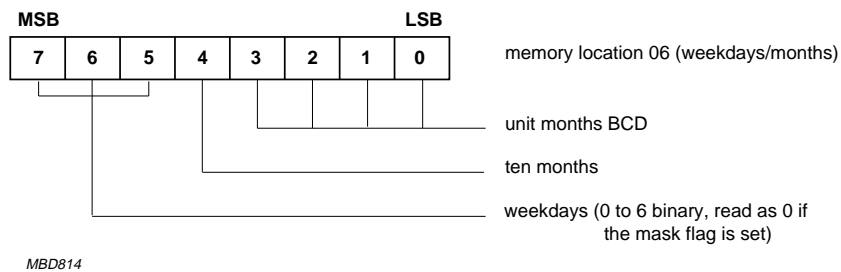

Fig.7 Format of the weekdays/months counter.

Low power clock/calendar

PCF8593

Table 1 Cycle length of the time counters, clock modes.

UNIT	COUNTING CYCLE	CARRY TO NEXT UNIT	CONTENTS OF THE MONTH COUNTER
Hundredths of a second	00 to 99	99 to 00	–
Seconds	00 to 59	59 to 00	–
Minutes	00 to 59	59 to 00	–
Hours (24 h)	00 to 23	23 to 00	–
Hours (12 h)	12 AM	–	–
	01 AM to 11 AM	–	–
	12 PM	–	–
	01 PM to 11 PM	11 PM to 12 AM	–
Date	01 to 31	31 to 01	1, 3, 5, 7, 8, 10 and 12
	01 to 30	30 to 01	4, 6, 9 and 11
	01 to 29	29 to 01	2, year = 0
	01 to 28	28 to 01	2, year = 1, 2 and 3
Months	01 to 12	12 to 01	–
Year	0 to 3	–	–
Weekdays	0 to 6	6 to 0	–
Timer	00 to 99	no carry	–

7.5 Alarm control register

When the alarm enable bit of the control/status register is set (address 00, bit 2) the alarm control register (address 08) is activated. All alarm, timer, and interrupt output functions are controlled by the contents of the alarm control register (see Fig.8).

7.6 Alarm registers

All alarm registers are allocated with a constant address offset of hexadecimal 08 to the corresponding counter registers (see Fig.4, Register arrangement).

An alarm signal is generated when the contents of the alarm registers matches bit-by-bit the contents of the involved counter registers. The year and weekday bits are ignored in a dated alarm. A daily alarm ignores the month and date bits. When a weekday alarm is selected, the contents of the alarm weekday/month register will select the weekdays on which an alarm is activated (see Fig.9).

Remark: in the 12 h mode, bits 6 and 7 of the alarm hours register must be the same as the hours counter.

Low power clock/calendar

PCF8593

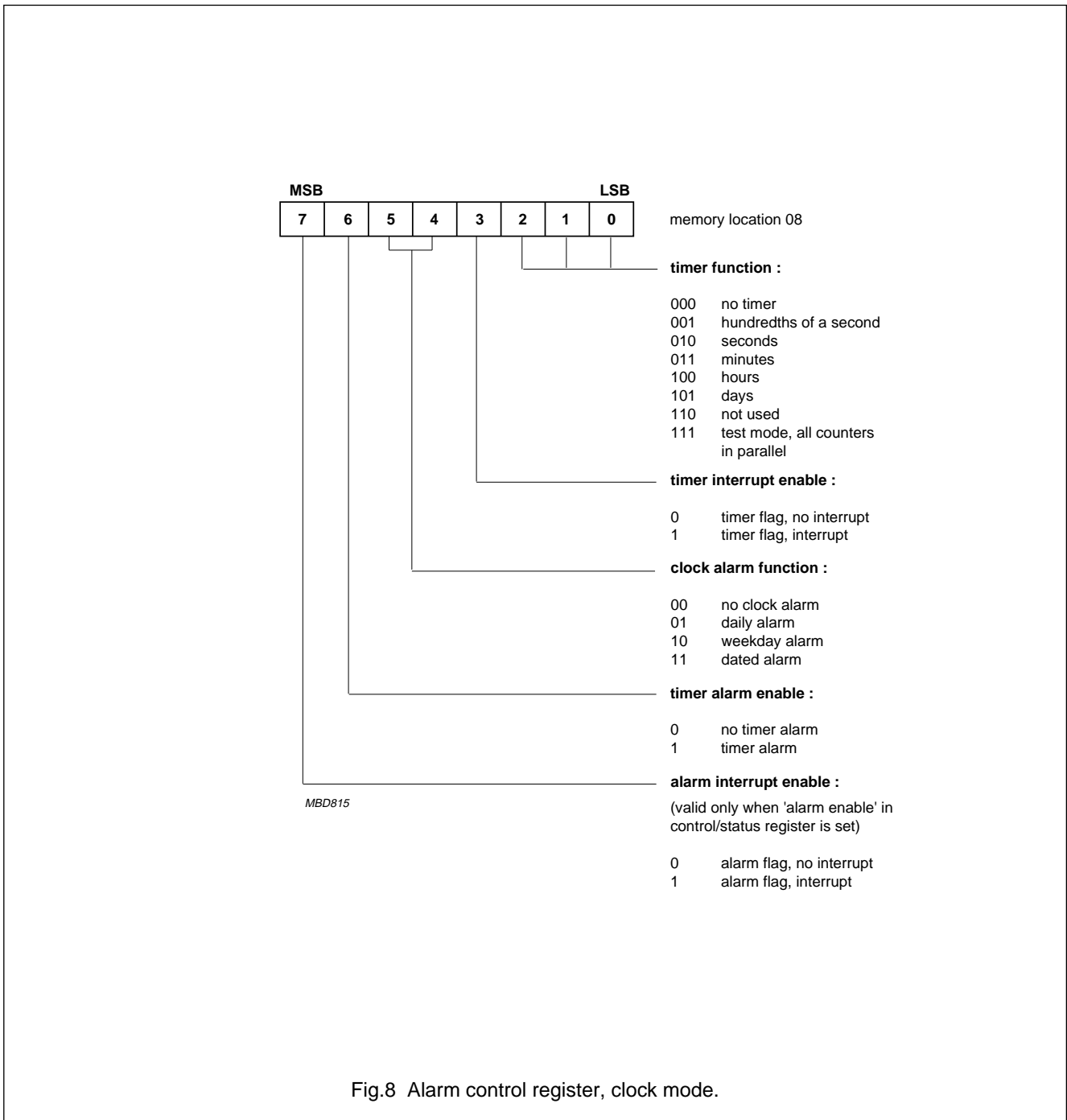
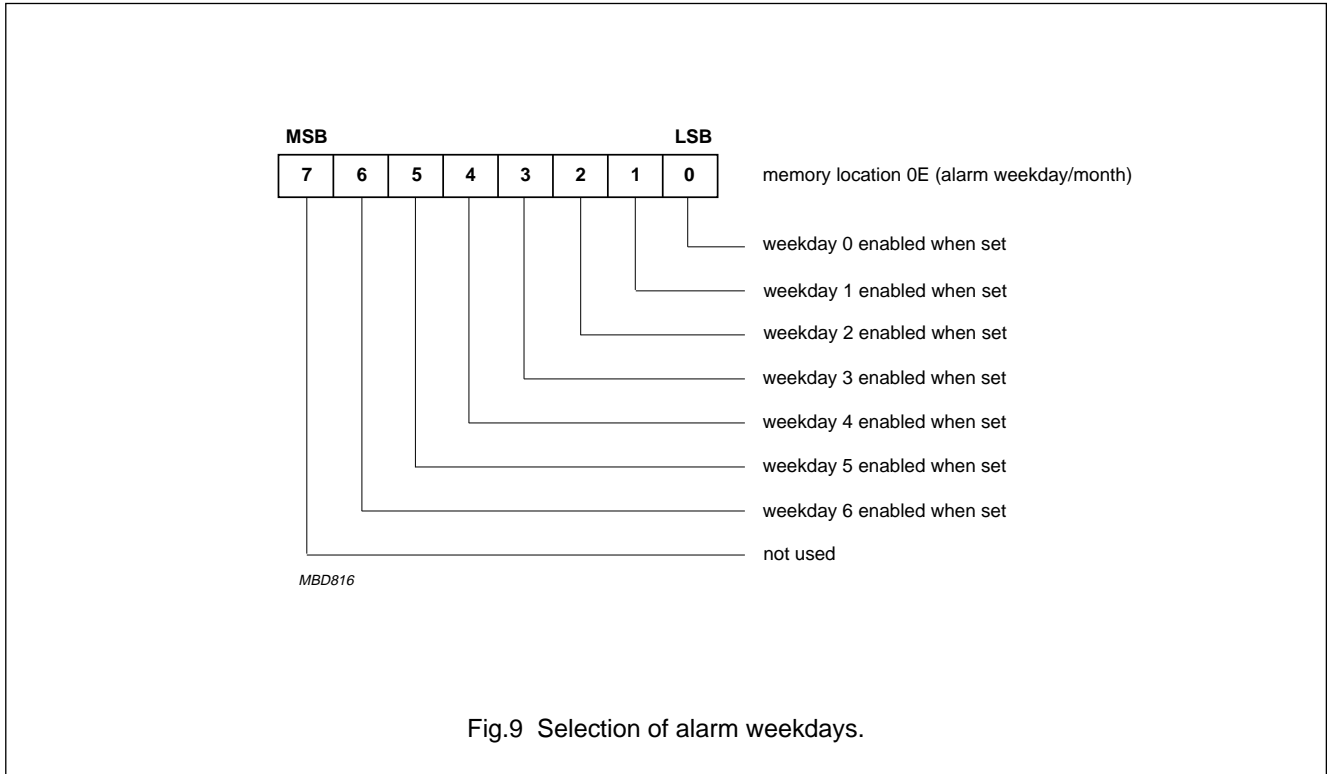

Fig.8 Alarm control register, clock mode.

Low power clock/calendar

PCF8593



7.7 Timer

The timer (location 07) is enabled by setting the control/status register = XX0X X1XX. The timer counts up from 0 (or a programmed value) to 99. On overflow, the timer resets to 0. The timer flag (LSB of control/status register) is set on overflow of the timer. This flag must be reset by software. The inverted value of this flag can be transferred to the external interrupt by setting bit 3 of the alarm control register.

Additionally, a timer alarm can be programmed by setting the timer alarm enable (bit 6 of the alarm control register). When the value of the timer equals a pre-programmed value in the alarm timer register (location 0F), the alarm flag is set (bit 1 of the control/status register). The inverted value of the alarm flag can be transferred to the external interrupt by enabling the alarm interrupt (bit 6 of the alarm control register).

Resolution of the timer is programmed via the 3 LSBs of the alarm control register (see Fig.11, Alarm and timer Interrupt logic diagram).

7.8 Event counter mode

Event counter mode is selected by bits 4 and 5 which are logic 1, 0 in the control/status register. The event counter mode is used to count pulses externally applied to the oscillator input (OSCO left open-circuit). The event counter stores up to 6 digits of data, which are stored as 6 hexadecimal values located in locations 1, 2, and 3. Thus, up to 1 million events may be recorded.

An event counter alarm occurs when the event counter registers match the value programmed in locations 9, A, and B, and the event alarm is enabled (bits 4 and 5 which are logic 0, 1 in the alarm control register). In this event, the alarm flag (bit 1 of the control/status register) is set. The inverted value of this flag can be transferred to the interrupt pin (pin 7) by setting the alarm interrupt enable in the alarm control register. In this mode, the timer (location 07) increments once for every one, one-hundred, ten thousand, or 1 million events, depending on the value programmed in bits 0,1 and 2 of the alarm control register. In all other events, the timer functions are as in the clock mode.

Low power clock/calendar

PCF8593

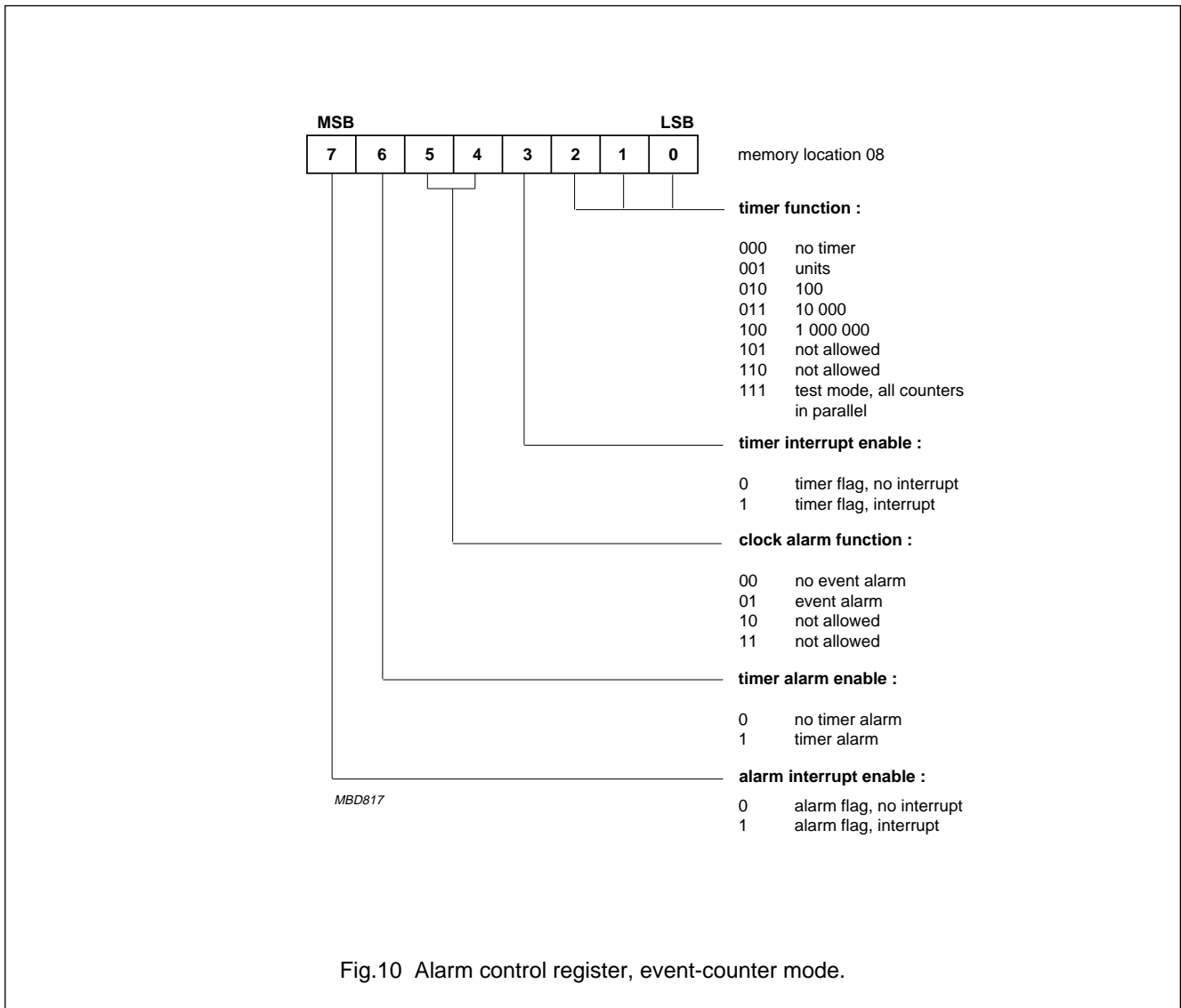

7.9 Interrupt output

The conditions for activating the open-drain n-channel interrupt output \overline{INT} (active LOW) are determined by appropriate programming of the alarm control register. These conditions are clock alarm, timer alarm, timer overflow, and event counter alarm. An interrupt occurs when the alarm flag or the timer flag is set, and the corresponding interrupt is enabled. In all events, the interrupt is cleared only by software resetting of the flag which initiated the interrupt.

In the clock mode, if the alarm enable is not activated (alarm enable bit of control/status register is logic 0), the interrupt output toggles at 1 Hz with a 50% duty cycle (may be used for calibration). The OFF voltage of the interrupt output may exceed the supply voltage, up to a maximum of 6.0 V. A logic diagram of the interrupt output is shown in Fig.11.

Low power clock/calendar

PCF8593

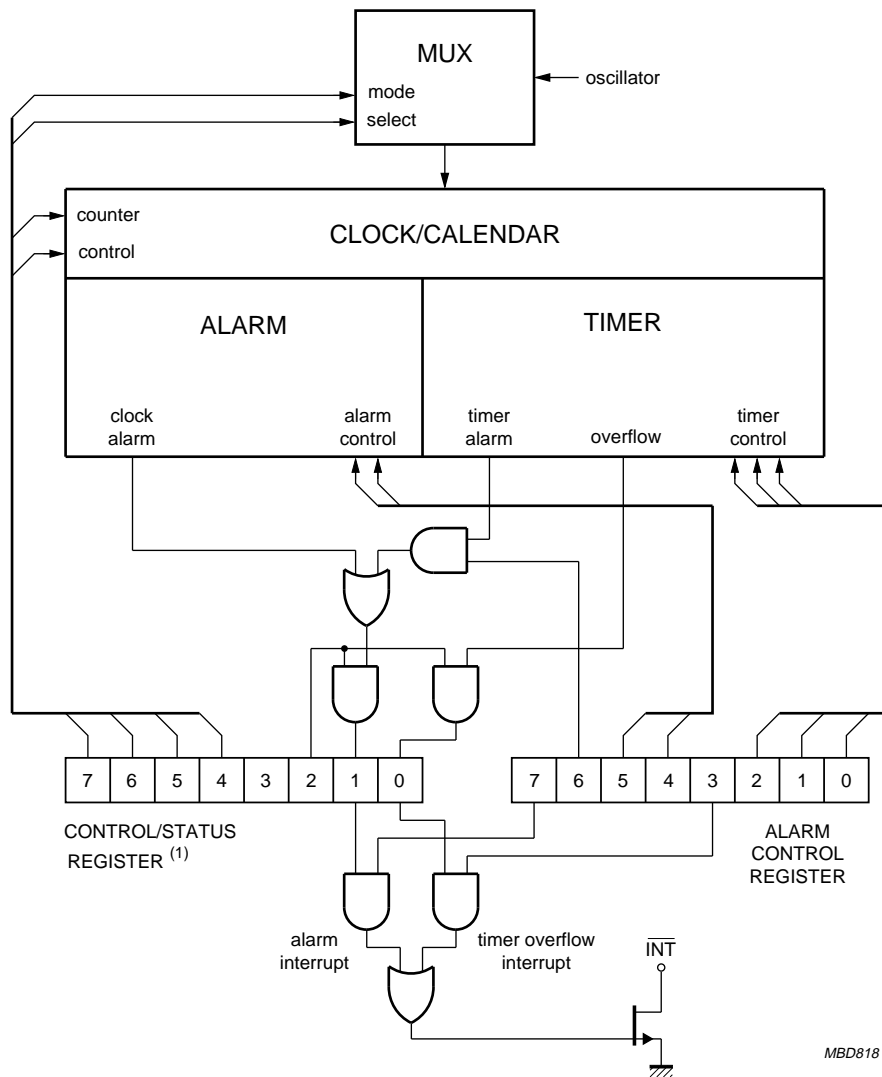

MBD818

(1) If the alarm enable bit of the control/status register is reset (logic 0), a 1 Hz signal can be observed on the interrupt pin \overline{INT} .

Fig.11 Alarm and timer interrupt logic diagram.

Low power clock/calendar

PCF8593

7.10 Oscillator and divider

A 32.768 kHz quartz crystal has to be connected to OSC1 (pin 1) and OSC0 (pin 2). A trimmer capacitor between OSC1 and V_{DD} is used for tuning the oscillator (see Chapter 14, Section 14.1). A 100 Hz clock signal is derived from the quartz oscillator for the clock counters.

In the 50 Hz clock mode or event-counter mode the oscillator is disabled and the oscillator input is switched to a high-impedance state. This allows the user to feed the 50 Hz reference frequency or an external high-speed event signal into the input OSC1.

7.10.1 DESIGNING

When designing the printed-circuit board layout, keep the oscillator components as close to the IC package as possible, and keep all other signal lines as far away as possible. In applications involving tight packing of components, shielding of the oscillator may be necessary. AC coupling of extraneous signals can introduce oscillator inaccuracy.

7.11 Initialization (see Fig.12)

Note that immediately following power-on, all internal registers are undefined and, following a $\overline{\text{RESET}}$ pulse on pin 3, must be defined via software. Attention should be paid to the possibility that the device may be initially in event-counter mode, in which event the oscillator will not operate. Over-ride can be achieved via software.

Reset is accomplished by applying an external $\overline{\text{RESET}}$ pulse (active LOW) at pin 3. When reset occurs only the I²C-bus interface is reset. The control/status register and all clock counters are not affected by $\overline{\text{RESET}}$. $\overline{\text{RESET}}$ must return HIGH during device operation.

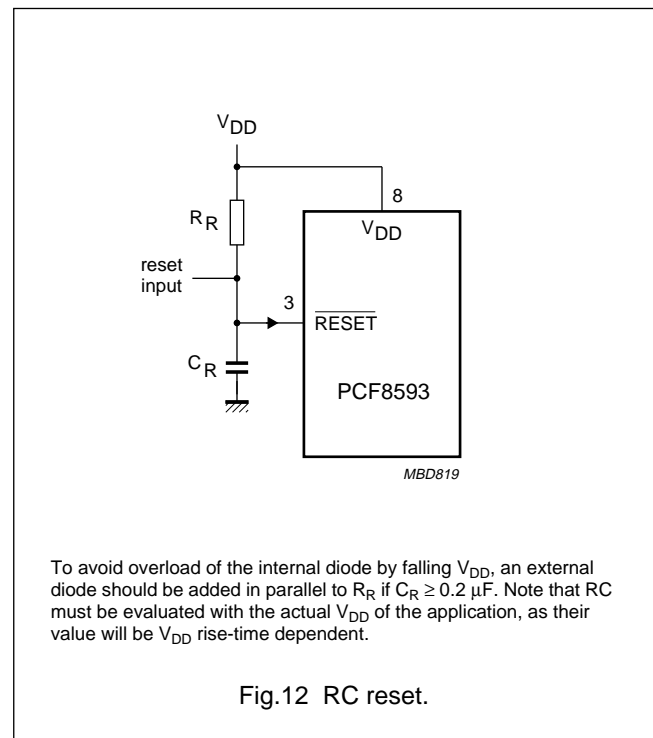

An RC combination can also be utilized to provide a power-on $\overline{\text{RESET}}$ signal at pin 3. In this event, the values of the RC must fulfil the following relationship to guarantee power-on reset (see Fig.12).

$\overline{\text{RESET}}$ input must be $\leq 0.3V_{DD}$ when V_{DD} reaches V_{DDmin} (or higher).

It is recommended to set the stop counting flag of the control/status register before loading the actual time into the counters. Loading of illegal states may lead to a temporary clock malfunction.

Low power clock/calendar

PCF8593

8 CHARACTERISTICS OF THE I²C-BUS

The I²C-bus is for bidirectional, two-line communication between different ICs or modules. The two lines are a serial data line (SDA) and a serial clock line (SCL). Both lines must be connected to a positive supply via a pull-up resistor. Data transfer may be initiated only when the bus is not busy.

8.1 Bit transfer (see Fig.13)

One data bit is transferred during each clock pulse. The data on the SDA line must remain stable during the HIGH period of the clock pulse as changes in the data line at this time will be interpreted as a control signal.

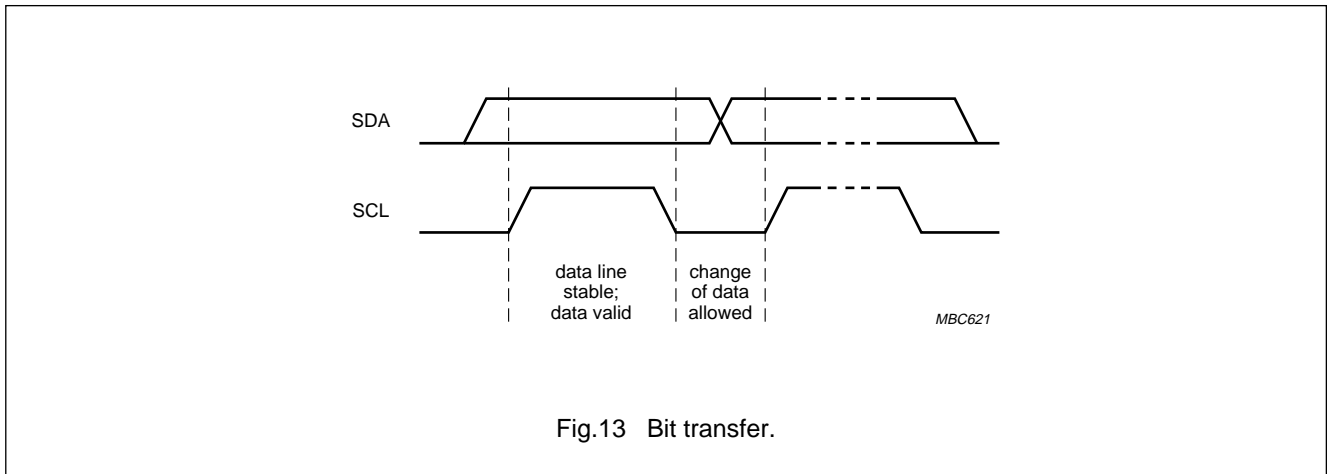

Fig.13 Bit transfer.

8.2 Start and stop conditions (see Fig.14)

Both data and clock lines remain HIGH when the bus is not busy. A HIGH-to-LOW transition of the data line, while the clock is HIGH is defined as the start condition (S). A LOW-to-HIGH transition of the data line while the clock is HIGH is defined as the stop condition (P).

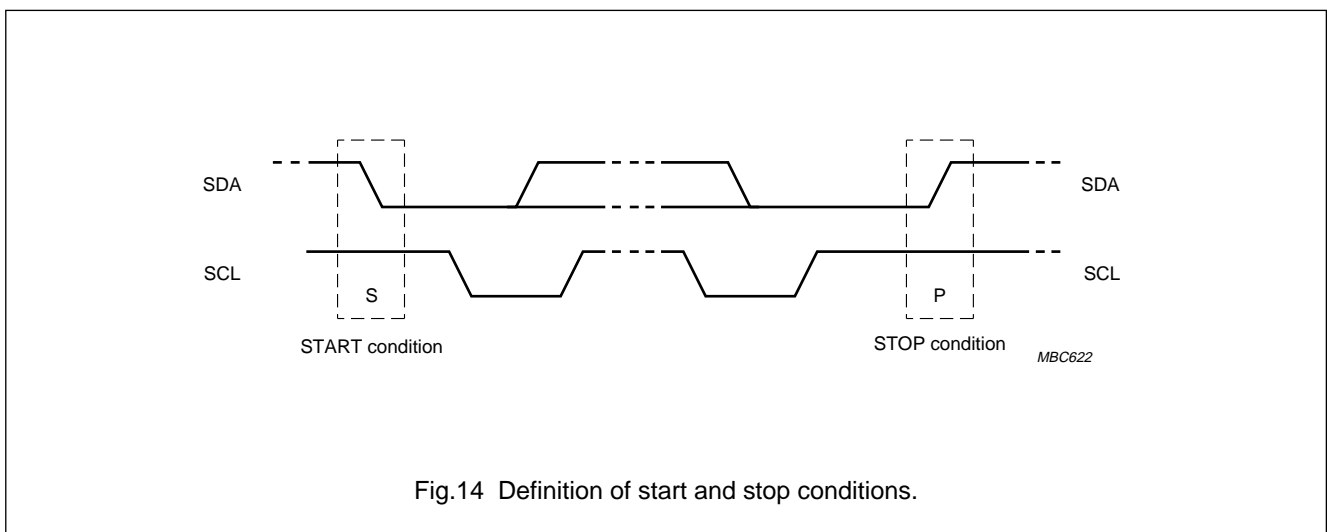

Fig.14 Definition of start and stop conditions.

Low power clock/calendar

PCF8593

8.3 System configuration (see Fig.15)

A device generating a message is a 'transmitter', a device receiving a message is the 'receiver'. The device that controls the message is the 'master' and the devices which are controlled by the master are the 'slaves'.

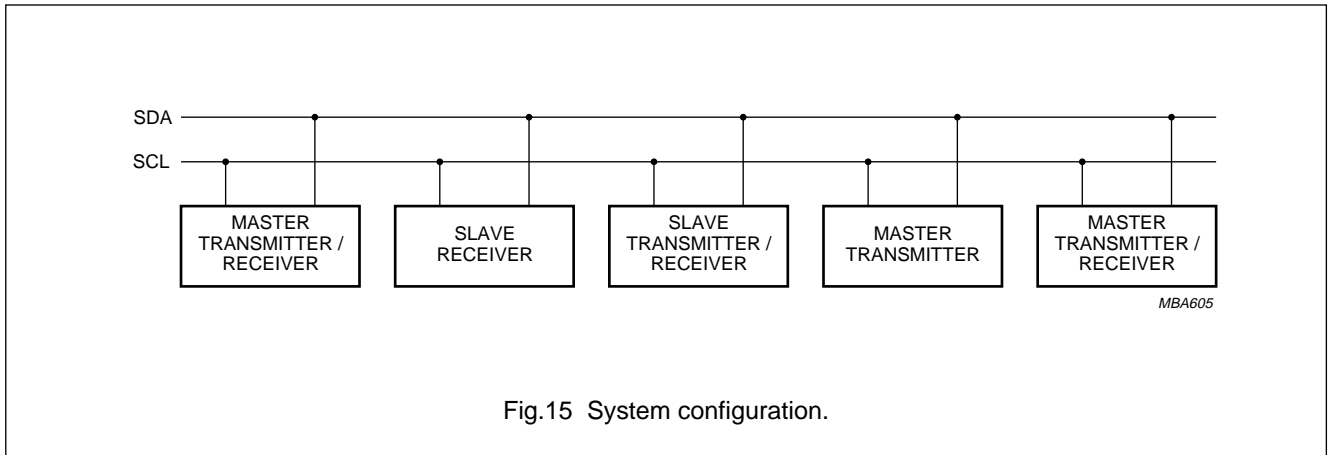

Fig.15 System configuration.

8.4 Acknowledge (see Fig.16)

The number of data bytes transferred between the start and stop conditions from transmitter to receiver is unlimited. Each byte of eight bits is followed by an acknowledge bit. The acknowledge bit is a HIGH level signal put on the bus by the transmitter during which time the master generates an extra acknowledge related clock pulse. A slave receiver which is addressed must generate an acknowledge after the reception of each byte. Also a master receiver must generate an acknowledge after the reception of each byte that has been clocked out of the slave transmitter.

The device that acknowledges must pull down the SDA line during the acknowledge clock pulse, so that the SDA line is stable LOW during the HIGH period of the acknowledge related clock pulse (set-up and hold times must be taken into consideration). A master receiver must signal an end of data to the transmitter by **not** generating an acknowledge on the last byte that has been clocked out of the slave. In this event the transmitter must leave the data line HIGH to enable the master to generate a stop condition.

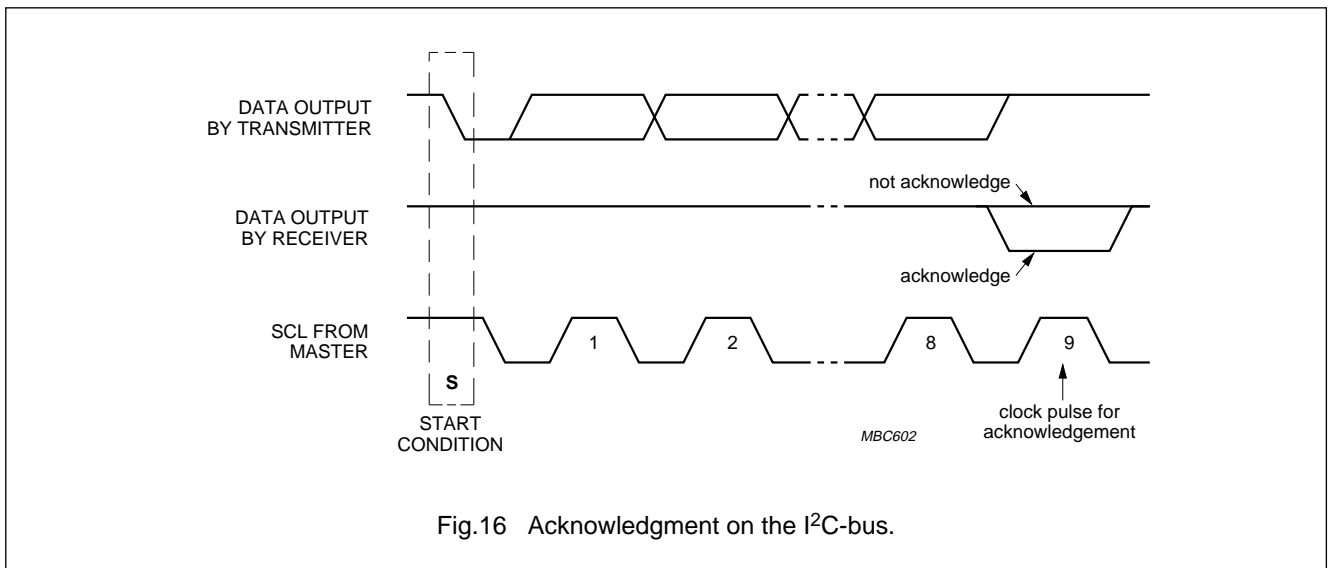

Fig.16 Acknowledgment on the I²C-bus.

Low power clock/calendar

PCF8593

9 I²C-BUS PROTOCOL

9.1 Addressing

Before any data is transmitted on the I²C-bus, the device which should respond is addressed first. The addressing is always carried out with the first byte transmitted after the start procedure.

The clock/calendar acts as a slave receiver or slave transmitter. Therefore the clock signal SCL is only an input signal, but the data signal SDA is a bidirectional line. The clock/calendar slave address is shown in Fig.17.

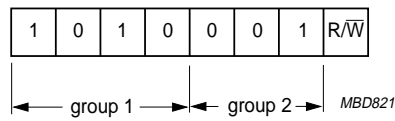

Fig.17 Slave address.

9.2 Clock/calendar READ/WRITE cycles

The I²C-bus configuration for the different PCF8593 READ and WRITE cycles is shown in Figs 18, 19 and 20.

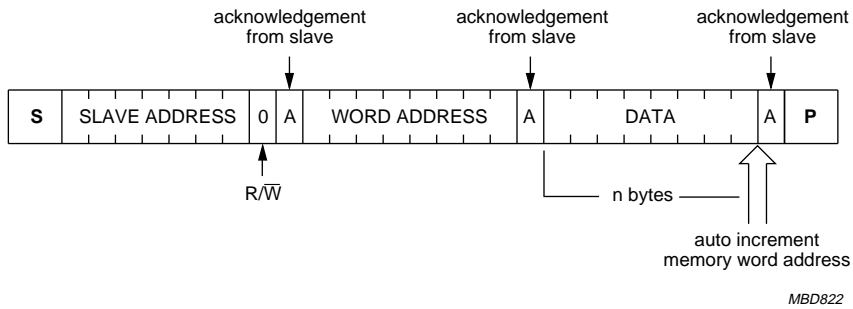

Fig.18 Master transmits to slave receiver (WRITE) mode.

Low power clock/calendar

PCF8593

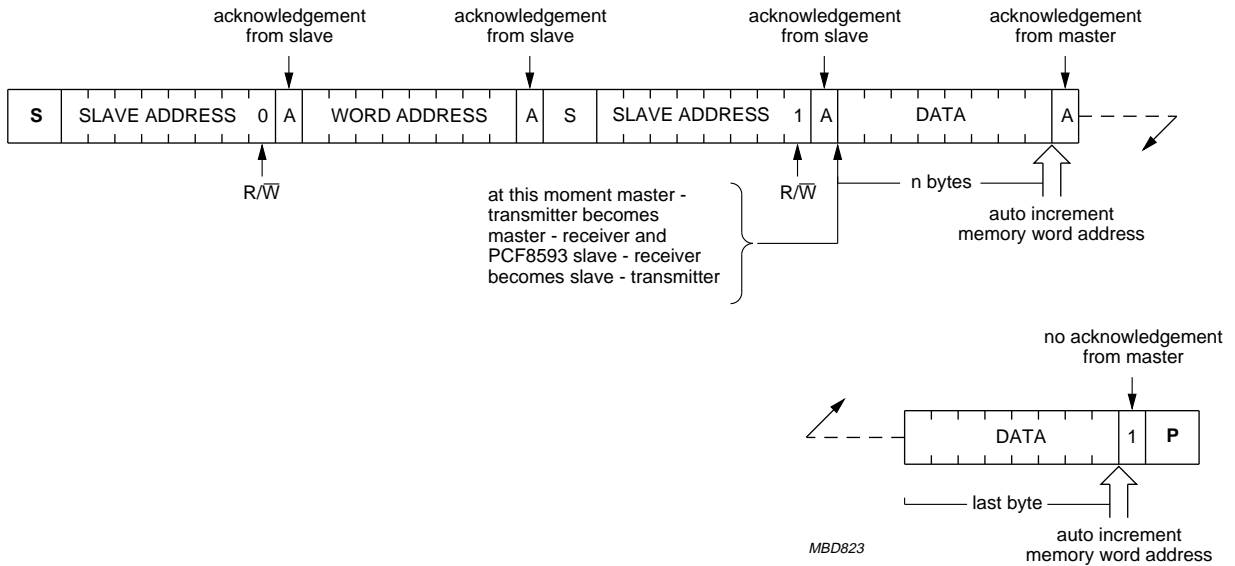

Fig.19 Master reads after setting word address (write word address, READ data).

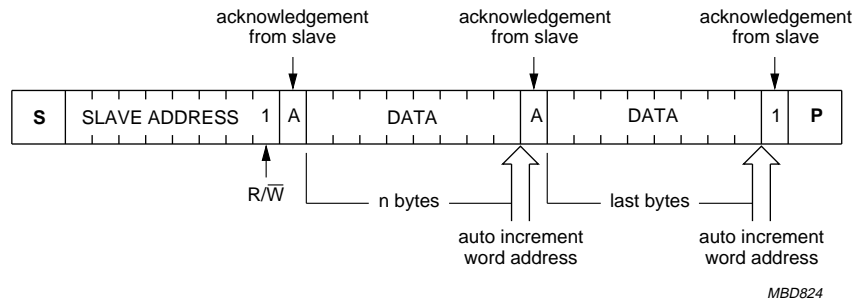

Fig.20 Master reads slave immediately after first byte (READ mode).

Low power clock/calendar

PCF8593

10 LIMITING VALUES

In accordance with the Absolute Maximum Rating System (IEC 134).

SYMBOL	PARAMETER	MIN.	MAX.	UNIT
V_{DD}	supply voltage (pin 8)	-0.8	+7.0	V
I_{DD}	supply current (pin 8)	-	50	mA
I_{SS}	supply current (pin 4)	-	50	mA
V_I	input voltage	-0.8	$V_{DD} + 0.8$	V
I_I	input current	-	10	mA
I_O	DC output current	-	10	mA
P_{tot}	total power dissipation per package	-	300	mW
P_O	power dissipation per output	-	50	mW
T_{amb}	operating ambient temperature	-40	+85	°C
T_{stg}	storage temperature	-65	+150	°C

11 HANDLING

Inputs and outputs are protected against electrostatic discharge in normal handling. However, to be totally safe, it is desirable to take precautions appropriate to handling MOS devices. Advice can be found in Data Handbook IC12 under "Handling MOS Devices".

12 DC CHARACTERISTICS

$V_{DD} = 2.5$ to 6.0 V; $V_{SS} = 0$ V; $T_{amb} = -40$ to $+85$ °C; $f_{osc} = 32$ kHz; unless otherwise specified.

SYMBOL	PARAMETER	CONDITIONS	MIN.	TYP. ⁽¹⁾	MAX.	UNIT
Supply						
V_{DD}	supply voltage (operating mode)	I ² C-bus active	2.5	-	6.0	V
		I ² C-bus inactive	1.0	-	6.0	V
V_{DDosc}	supply voltage (quartz oscillator)	note 2				
		$T_{amb} = 0$ to 70 °C	1.0	-	6.0	V
		$T_{amb} = -40$ to 85 °C	1.2	-	6.0	V
I_{DD}	supply current (operating mode)	$f_{scl} = 100$ kHz; clock mode; note 3	-	-	200	µA
I_{DDO}	supply current (clock mode with I ² C-bus inactive)	$f_{scl} = 0$ Hz; inputs at V_{DD} or V_{SS}				
		$V_{DD} = 2$ V	-	1.0	8.0	µA
		$V_{DD} = 5$ V	-	4.0	15	µA
SDA, SCL, INT and RESET						
V_{IL}	LOW level input voltage		0	-	$0.3V_{DD}$	V
V_{IH}	HIGH level input voltage		$0.7V_{DD}$	-	V_{DD}	V
I_{OL}	LOW level output current	$V_{OL} = 0.4$ V	3	-	-	mA
I_{LI}	input leakage current	$V_I = V_{DD}$ or V_{SS}	-1	-	+1	µA

Low power clock/calendar

PCF8593

SYMBOL	PARAMETER	CONDITIONS	MIN.	TYP. ⁽¹⁾	MAX.	UNIT
C _i	input capacitance	note 4	–	–	7	pF
OSCI and RESET						
I _{LI}	input leakage current	V _I = V _{DD} or V _{SS}	–250	–	+250	nA
INT						
I _{OL}	LOW level output current	V _{OL} = 0.4 V	1	–	–	mA
I _{LI}	input leakage current	V _I = V _{DD} or V _{SS}	–1	–	+1	μA
SCL						
C _i	input capacitance	note 4	–	–	7	pF
I _{LI}	input leakage current	V _I = V _{DD} or V _{SS}	–1	–	+1	μA

Notes

1. Typical values measured at T_{amb} = 25 °C.
2. When powering up the device, V_{DD} must exceed the specified minimum value by 300 mV to guarantee correct start-up of the oscillator.
3. Event counter mode: supply current dependent upon input frequency.
4. Tested on sample basis.

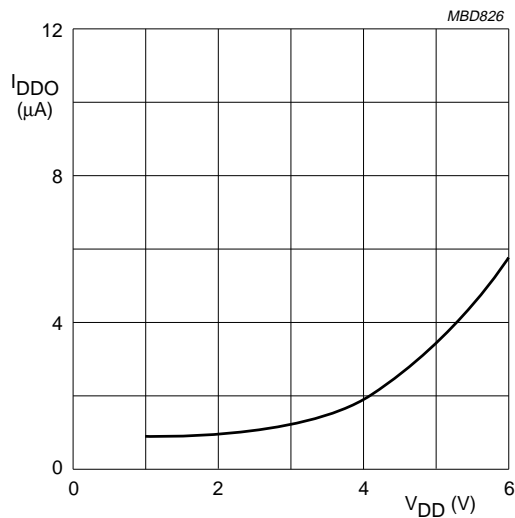

f_{SCL} = 32 kHz; T_{amb} = 25 °C.

Fig.21 Typical supply current in clock mode as a function of supply voltage.

Low power clock/calendar

PCF8593

13 AC CHARACTERISTICS

$V_{DD} = 2.5$ to 6.0 V; $V_{SS} = 0$ V; $T_{amb} = -40$ to $+85$ °C; unless otherwise specified.

SYMBOL	PARAMETER	CONDITIONS	MIN.	TYP.	MAX.	UNIT
Oscillator						
C_{osc}	integrated oscillator capacitance		20	25	30	pF
Δf_{osc}	oscillator stability	for $\Delta V_{DD} = 100$ mV; $T_{amb} = 25$ °C; $V_{DD} = 1.5$ V	–	2×10^{-7}	–	
f_i	input frequency	note 1	–	–	1	MHz
Quartz crystal parameters (f = 32.768 kHz)						
R_s	series resistance		–	–	40	k Ω
C_L	parallel load capacitance		–	10	–	pF
C_T	trimmer capacitance		5	–	25	pF
I²C-bus timing (see Fig.22; notes 2 and 3)						
f_{SCL}	SCL clock frequency		–	–	100	kHz
t_{SP}	tolerable spike width on bus		–	–	100	ns
t_{BUF}	bus free time		4.7	–	–	μ s
$t_{SU;STA}$	START condition set-up time		4.7	–	–	μ s
$t_{HD;STA}$	START condition hold time		4.0	–	–	μ s
t_{LOW}	SCL LOW time		4.7	–	–	μ s
t_{HIGH}	SCL HIGH time		4.0	–	–	μ s
t_r	SCL and SDA rise time		–	–	1.0	μ s
t_f	SCL and SDA fall time		–	–	0.3	μ s
$t_{SU;DAT}$	data set-up time		250	–	–	ns
$t_{HD;DAT}$	data hold time		0	–	–	ns
$t_{VD;DAT}$	SCL LOW to data out valid		–	–	3.4	μ s
$t_{SU;STO}$	STOP condition set-up time		4.0	–	–	μ s

Notes

1. Event counter mode only.
2. All timing values are valid within the operating supply voltage and ambient temperature range and reference to V_{IL} and V_{IH} with an input voltage swing of V_{SS} to V_{DD} .
3. A detailed description of the I²C-bus specification, with applications, is given in brochure "The I²C-bus and how to use it". This brochure may be ordered using the code 9398 393 40011.

Low power clock/calendar

PCF8593

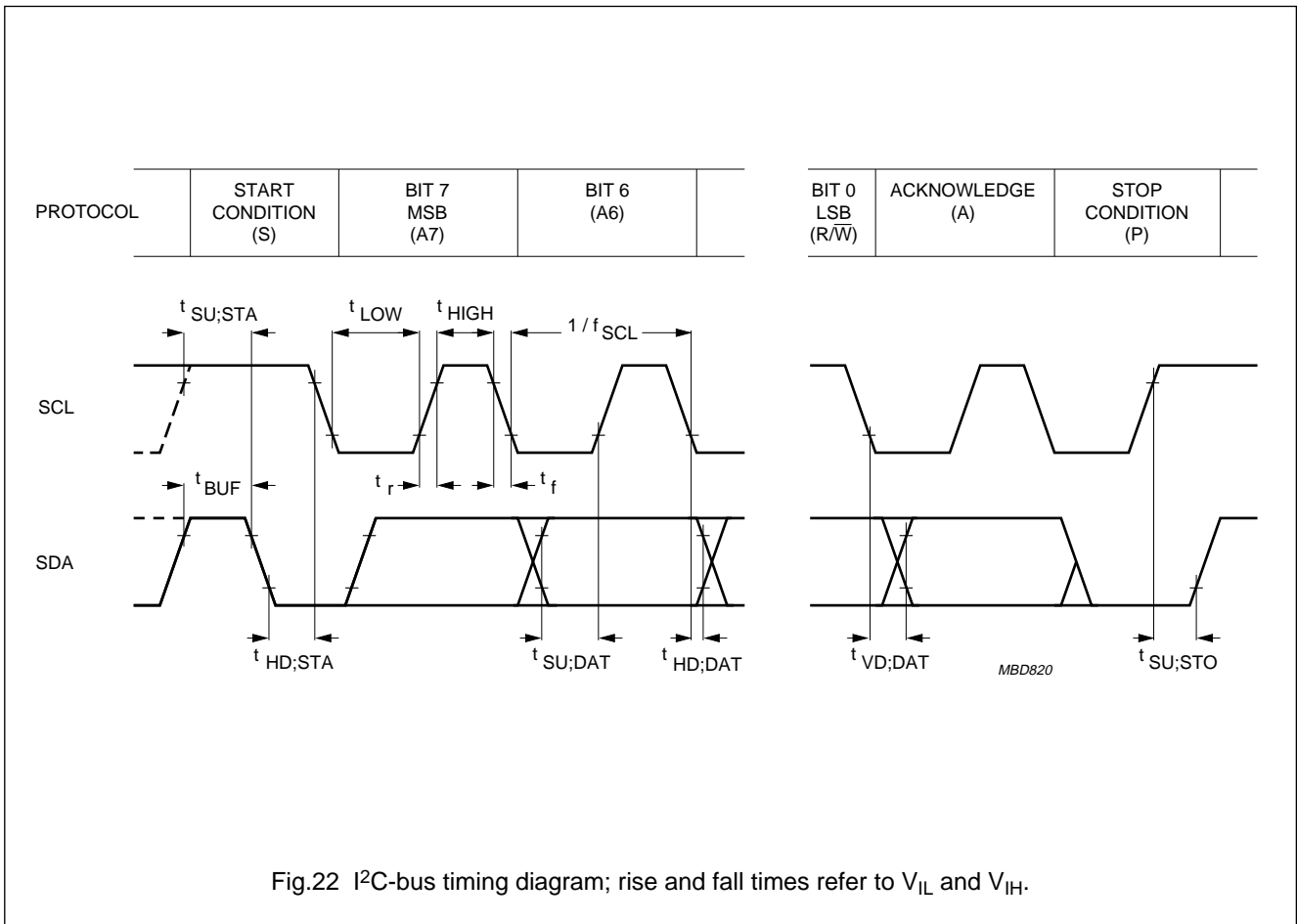

Low power clock/calendar

PCF8593

14 APPLICATION INFORMATION

14.1 Quartz frequency adjustment

14.1.1 METHOD 1: FIXED OSCIL CAPACITOR

By evaluating the average capacitance necessary for the application layout a fixed capacitor can be used. The frequency is best measured via the 1 Hz signal which can be programmed to occur at the interrupt output (pin 7). The frequency tolerance depends on the quartz crystal tolerance, the capacitor tolerance and the device-to-device tolerance (on average $\pm 5 \times 10^{-6}$). Average deviations of ± 5 minutes per year can be achieved.

14.1.2 METHOD 2: OSCIL TRIMMER

Using the alarm function (via the I²C-bus) a signal faster than 1 Hz can be generated at the interrupt output for fast setting of a trimmer.

Procedure:

- Power-on
- Apply $\overline{\text{RESET}}$
- Initialization (alarm functions).

Routine:

- Set clock to time T and set alarm to time T + ΔT
- At time T + ΔT (interrupt) repeat routine.

14.1.3 METHOD 3: DIRECT OUTPUT

Direct measurement of oscillator output (accounting for test probe capacitance).

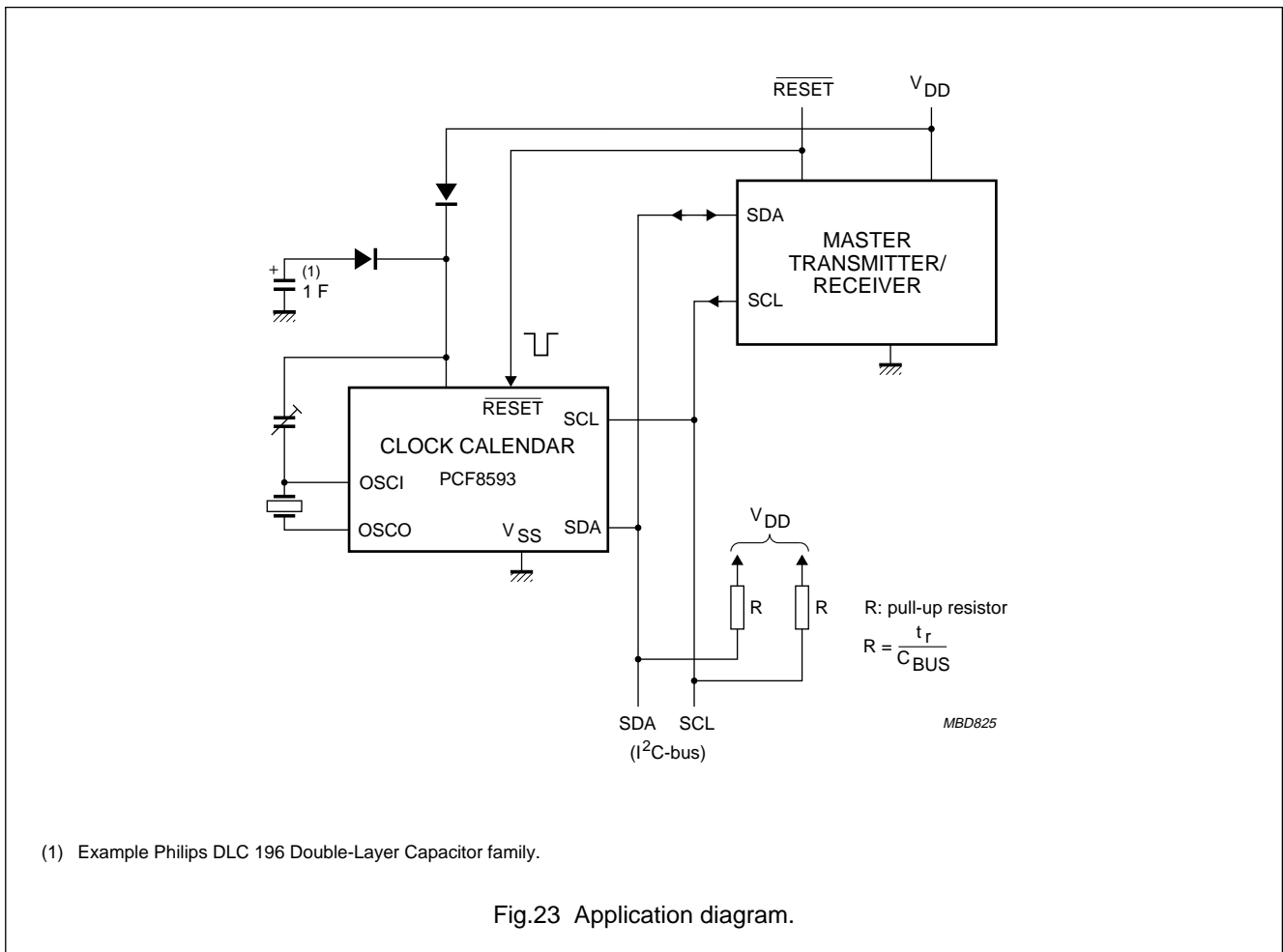

Low power clock/calendar

PCF8593

15 PACKAGE OUTLINES

DIP8: plastic dual in-line package; 8 leads (300 mil)

SOT97-1

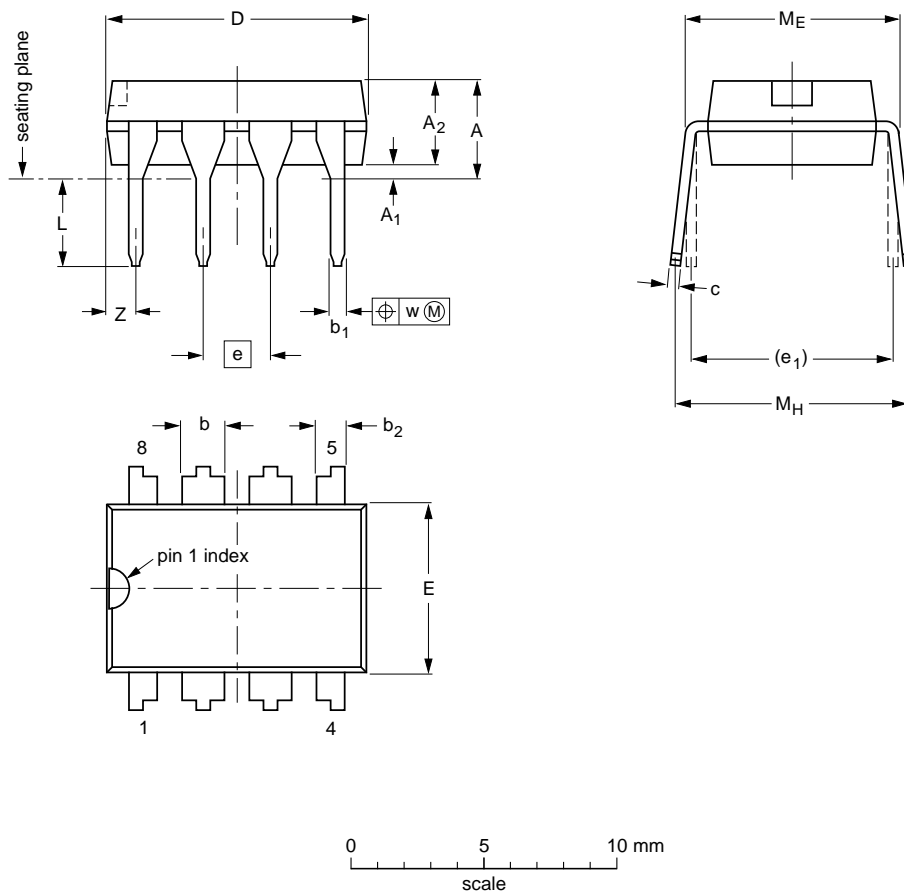

DIMENSIONS (inch dimensions are derived from the original mm dimensions)

UNIT	A max.	A ₁ min.	A ₂ max.	b	b ₁	b ₂	c	D ⁽¹⁾	E ⁽¹⁾	e	e ₁	L	M _E	M _H	w	Z ⁽¹⁾ max.
mm	4.2	0.51	3.2	1.73 1.14	0.53 0.38	1.07 0.89	0.36 0.23	9.8 9.2	6.48 6.20	2.54	7.62	3.60 3.05	8.25 7.80	10.0 8.3	0.254	1.15
inches	0.17	0.020	0.13	0.068 0.045	0.021 0.015	0.042 0.035	0.014 0.009	0.39 0.36	0.26 0.24	0.10	0.30	0.14 0.12	0.32 0.31	0.39 0.33	0.01	0.045

Note

1. Plastic or metal protrusions of 0.25 mm maximum per side are not included.

OUTLINE VERSION	REFERENCES				EUROPEAN PROJECTION	ISSUE DATE
	IEC	JEDEC	EIAJ			
SOT97-1	050G01	MO-001AN				92-11-17 95-02-04

Low power clock/calendar

PCF8593

S08: plastic small outline package; 8 leads; body width 3.9 mm

SOT96-1

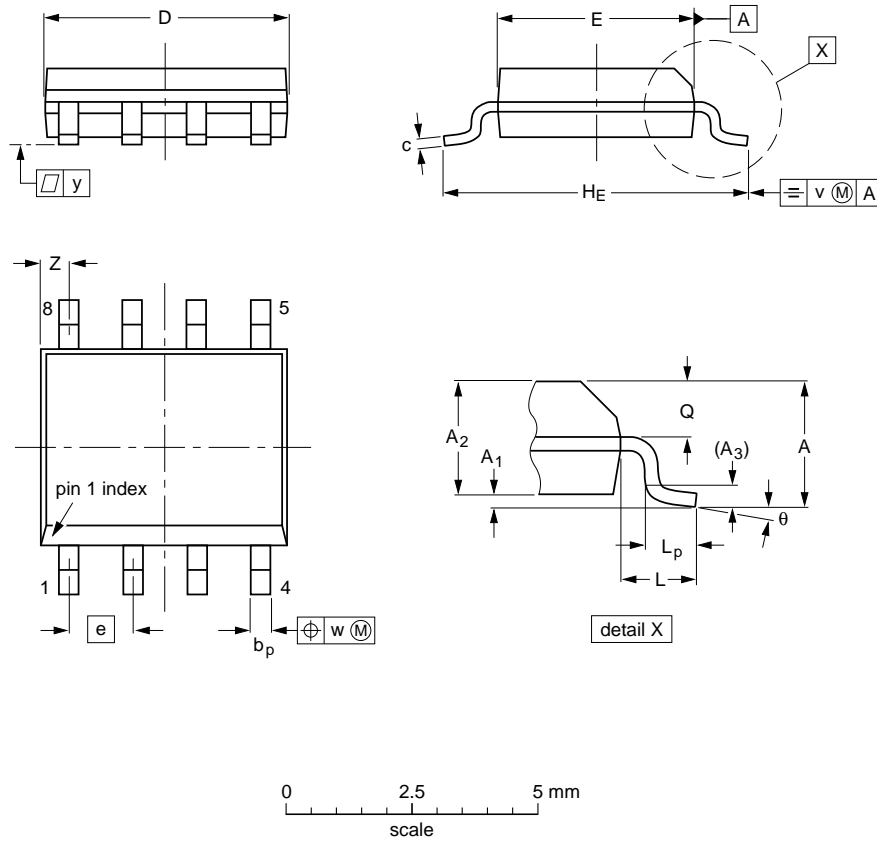

DIMENSIONS (inch dimensions are derived from the original mm dimensions)

UNIT	A max.	A ₁	A ₂	A ₃	b _p	c	D ⁽¹⁾	E ⁽²⁾	e	H _E	L	L _p	Q	v	w	y	Z ⁽¹⁾	θ
mm	1.75	0.25 0.10	1.45 1.25	0.25	0.49 0.36	0.25 0.19	5.0 4.8	4.0 3.8	1.27	6.2 5.8	1.05	1.0 0.4	0.7 0.6	0.25	0.25	0.1	0.7 0.3	8° 0°
inches	0.069	0.0098 0.0039	0.057 0.049	0.01	0.019 0.014	0.0098 0.0075	0.20 0.19	0.16 0.15	0.050	0.24 0.23	0.041	0.039 0.016	0.028 0.024	0.01	0.01	0.004	0.028 0.012	

Notes

1. Plastic or metal protrusions of 0.15 mm maximum per side are not included.
2. Plastic or metal protrusions of 0.25 mm maximum per side are not included.

OUTLINE VERSION	REFERENCES			EUROPEAN PROJECTION	ISSUE DATE
	IEC	JEDEC	EIAJ		
SOT96-1	076E03S	MS-012AA			92-11-17 95-02-04

Low power clock/calendar

PCF8593

16 SOLDERING

16.1 Introduction

There is no soldering method that is ideal for all IC packages. Wave soldering is often preferred when through-hole and surface mounted components are mixed on one printed-circuit board. However, wave soldering is not always suitable for surface mounted ICs, or for printed-circuits with high population densities. In these situations reflow soldering is often used.

This text gives a very brief insight to a complex technology. A more in-depth account of soldering ICs can be found in our "IC Package Databook" (order code 9398 652 90011).

16.2 DIP

16.2.1 SOLDERING BY DIPPING OR BY WAVE

The maximum permissible temperature of the solder is 260 °C; solder at this temperature must not be in contact with the joint for more than 5 seconds. The total contact time of successive solder waves must not exceed 5 seconds.

The device may be mounted up to the seating plane, but the temperature of the plastic body must not exceed the specified maximum storage temperature ($T_{stg\ max}$). If the printed-circuit board has been pre-heated, forced cooling may be necessary immediately after soldering to keep the temperature within the permissible limit.

16.2.2 REPAIRING SOLDERED JOINTS

Apply a low voltage soldering iron (less than 24 V) to the lead(s) of the package, below the seating plane or not more than 2 mm above it. If the temperature of the soldering iron bit is less than 300 °C it may remain in contact for up to 10 seconds. If the bit temperature is between 300 and 400 °C, contact may be up to 5 seconds.

16.3 SO

16.3.1 REFLOW SOLDERING

Reflow soldering techniques are suitable for all SO packages.

Reflow soldering requires solder paste (a suspension of fine solder particles, flux and binding agent) to be applied to the printed-circuit board by screen printing, stencilling or pressure-syringe dispensing before package placement.

Several techniques exist for reflowing; for example, thermal conduction by heated belt. Dwell times vary between 50 and 300 seconds depending on heating method. Typical reflow temperatures range from 215 to 250 °C.

Preheating is necessary to dry the paste and evaporate the binding agent. Preheating duration: 45 minutes at 45 °C.

16.3.2 WAVE SOLDERING

Wave soldering techniques can be used for all SO packages if the following conditions are observed:

- A double-wave (a turbulent wave with high upward pressure followed by a smooth laminar wave) soldering technique should be used.
- The longitudinal axis of the package footprint must be parallel to the solder flow.
- The package footprint must incorporate solder thieves at the downstream end.

During placement and before soldering, the package must be fixed with a droplet of adhesive. The adhesive can be applied by screen printing, pin transfer or syringe dispensing. The package can be soldered after the adhesive is cured.

Maximum permissible solder temperature is 260 °C, and maximum duration of package immersion in solder is 10 seconds, if cooled to less than 150 °C within 6 seconds. Typical dwell time is 4 seconds at 250 °C.

A mildly-activated flux will eliminate the need for removal of corrosive residues in most applications.

16.3.3 REPAIRING SOLDERED JOINTS

Fix the component by first soldering two diagonally-opposite end leads. Use only a low voltage soldering iron (less than 24 V) applied to the flat part of the lead. Contact time must be limited to 10 seconds at up to 300 °C. When using a dedicated tool, all other leads can be soldered in one operation within 2 to 5 seconds between 270 and 320 °C.

Low power clock/calendar

PCF8593

17 DEFINITIONS

Data sheet status	
Objective specification	This data sheet contains target or goal specifications for product development.
Preliminary specification	This data sheet contains preliminary data; supplementary data may be published later.
Product specification	This data sheet contains final product specifications.
Limiting values	
Limiting values given are in accordance with the Absolute Maximum Rating System (IEC 134). Stress above one or more of the limiting values may cause permanent damage to the device. These are stress ratings only and operation of the device at these or at any other conditions above those given in the Characteristics sections of the specification is not implied. Exposure to limiting values for extended periods may affect device reliability.	
Application information	
Where application information is given, it is advisory and does not form part of the specification.	

18 LIFE SUPPORT APPLICATIONS

These products are not designed for use in life support appliances, devices, or systems where malfunction of these products can reasonably be expected to result in personal injury. Philips customers using or selling these products for use in such applications do so at their own risk and agree to fully indemnify Philips for any damages resulting from such improper use or sale.

19 PURCHASE OF PHILIPS I²C COMPONENTS

Purchase of Philips I²C components conveys a license under the Philips' I²C patent to use the components in the I²C system provided the system conforms to the I²C specification defined by Philips. This specification can be ordered using the code 9398 393 40011.

Philips Semiconductors – a worldwide company

Argentina: see South America

Australia: 34 Waterloo Road, NORTH RYDE, NSW 2113,
Tel. +61 2 9805 4455, Fax. +61 2 9805 4466

Austria: Computerstr. 6, A-1101 WIEN, P.O. Box 213,
Tel. +43 1 60 101, Fax. +43 1 60 101 1210

Belarus: Hotel Minsk Business Center, Bld. 3, r. 1211, Volodarski Str. 6,
220050 MINSK, Tel. +375 172 200 733, Fax. +375 172 200 773

Belgium: see The Netherlands

Brazil: see South America

Bulgaria: Philips Bulgaria Ltd., Energoproject, 15th floor,
51 James Bourchier Blvd., 1407 SOFIA,
Tel. +359 2 689 211, Fax. +359 2 689 102

Canada: PHILIPS SEMICONDUCTORS/COMPONENTS,
Tel. +1 800 234 7381

China/Hong Kong: 501 Hong Kong Industrial Technology Centre,
72 Tat Chee Avenue, Kowloon Tong, HONG KONG,
Tel. +852 2319 7888, Fax. +852 2319 7700

Colombia: see South America

Czech Republic: see Austria

Denmark: Prags Boulevard 80, PB 1919, DK-2300 COPENHAGEN S,
Tel. +45 32 88 2636, Fax. +45 31 57 1949

Finland: Sinikalliontie 3, FIN-02630 ESPOO,
Tel. +358 9 615800, Fax. +358 9 61580/xxx

France: 4 Rue du Port-aux-Vins, BP317, 92156 SURESNES Cedex,
Tel. +33 1 40 99 6161, Fax. +33 1 40 99 6427

Germany: Hammerbrookstraße 69, D-20097 HAMBURG,
Tel. +49 40 23 53 60, Fax. +49 40 23 536 300

Greece: No. 15, 25th March Street, GR 17778 TAVROS/ATHENS,
Tel. +30 1 4894 339/239, Fax. +30 1 4814 240

Hungary: see Austria

India: Philips INDIA Ltd, Shivsagar Estate, A Block, Dr. Annie Besant Rd.
Worli, MUMBAI 400 018, Tel. +91 22 4938 541, Fax. +91 22 4938 722

Indonesia: see Singapore

Ireland: Newstead, Clonskeagh, DUBLIN 14,
Tel. +353 1 7640 000, Fax. +353 1 7640 200

Israel: RAPAC Electronics, 7 Kehilat Saloniki St, TEL AVIV 61180,
Tel. +972 3 645 0444, Fax. +972 3 649 1007

Italy: PHILIPS SEMICONDUCTORS, Piazza IV Novembre 3,
20124 MILANO, Tel. +39 2 6752 2531, Fax. +39 2 6752 2557

Japan: Philips Bldg 13-37, Kohnan 2-chome, Minato-ku, TOKYO 108,
Tel. +81 3 3740 5130, Fax. +81 3 3740 5077

Korea: Philips House, 260-199 Itaewon-dong, Yongsan-ku, SEOUL,
Tel. +82 2 709 1412, Fax. +82 2 709 1415

Malaysia: No. 76 Jalan Universiti, 46200 PETALING JAYA, SELANGOR,
Tel. +60 3 750 5214, Fax. +60 3 757 4880

Mexico: 5900 Gateway East, Suite 200, EL PASO, TEXAS 79905,
Tel. +9-5 800 234 7381

Middle East: see Italy

Netherlands: Postbus 90050, 5600 PB EINDHOVEN, Bldg. VB,
Tel. +31 40 27 82785, Fax. +31 40 27 88399

New Zealand: 2 Wagener Place, C.P.O. Box 1041, AUCKLAND,
Tel. +64 9 849 4160, Fax. +64 9 849 7811

Norway: Box 1, Manglerud 0612, OSLO,
Tel. +47 22 74 8000, Fax. +47 22 74 8341

Philippines: Philips Semiconductors Philippines Inc.,
106 Valero St. Salcedo Village, P.O. Box 2108 MCC, MAKATI,
Metro MANILA, Tel. +63 2 816 6380, Fax. +63 2 817 3474

Poland: Ul. Lukiska 10, PL 04-123 WARSZAWA,
Tel. +48 22 612 2831, Fax. +48 22 612 2327

Portugal: see Spain

Romania: see Italy

Russia: Philips Russia, Ul. Usatcheva 35A, 119048 MOSCOW,
Tel. +7 095 755 6918, Fax. +7 095 755 6919

Singapore: Lorong 1, Toa Payoh, SINGAPORE 1231,
Tel. +65 350 2538, Fax. +65 251 6500

Slovakia: see Austria

Slovenia: see Italy

South Africa: S.A. PHILIPS Pty Ltd., 195-215 Main Road Martindale,
2092 JOHANNESBURG, P.O. Box 7430 Johannesburg 2000,
Tel. +27 11 470 5911, Fax. +27 11 470 5494

South America: Rua do Rocio 220, 5th floor, Suite 51,
04552-903 São Paulo, SÃO PAULO - SP, Brazil,
Tel. +55 11 821 2333, Fax. +55 11 829 1849

Spain: Balmes 22, 08007 BARCELONA,
Tel. +34 3 301 6312, Fax. +34 3 301 4107

Sweden: Kottbygatan 7, Akalla, S-16485 STOCKHOLM,
Tel. +46 8 632 2000, Fax. +46 8 632 2745

Switzerland: Allmendstrasse 140, CH-8027 ZÜRICH,
Tel. +41 1 488 2686, Fax. +41 1 481 7730

Taiwan: Philips Semiconductors, 6F, No. 96, Chien Kuo N. Rd., Sec. 1,
TAIPEI, Taiwan Tel. +886 2 2134 2870, Fax. +886 2 2134 2874

Thailand: PHILIPS ELECTRONICS (THAILAND) Ltd.,
209/2 Sanpavuth-Bangna Road Prakanong, BANGKOK 10260,
Tel. +66 2 745 4090, Fax. +66 2 398 0793

Turkey: Talatpasa Cad. No. 5, 80640 GÜLTEPE/ISTANBUL,
Tel. +90 212 279 2770, Fax. +90 212 282 6707

Ukraine: PHILIPS UKRAINE, 4 Patrice Lumumba str., Building B, Floor 7,
252042 KIEV, Tel. +380 44 264 2776, Fax. +380 44 268 0461

United Kingdom: Philips Semiconductors Ltd., 276 Bath Road, Hayes,
MIDDLESEX UB3 5BX, Tel. +44 181 730 5000, Fax. +44 181 754 8421

United States: 811 East Arques Avenue, SUNNYVALE, CA 94088-3409,
Tel. +1 800 234 7381

Uruguay: see South America

Vietnam: see Singapore

Yugoslavia: PHILIPS, Trg N. Pasica 5/v, 11000 BEOGRAD,
Tel. +381 11 625 344, Fax. +381 11 635 777

For all other countries apply to: Philips Semiconductors, Marketing & Sales Communications,
Building BE-p, P.O. Box 218, 5600 MD EINDHOVEN, The Netherlands, Fax. +31 40 27 24825

Internet: <http://www.semiconductors.philips.com>

© Philips Electronics N.V. 1997

SCA53

All rights are reserved. Reproduction in whole or in part is prohibited without the prior written consent of the copyright owner.

The information presented in this document does not form part of any quotation or contract, is believed to be accurate and reliable and may be changed without notice. No liability will be accepted by the publisher for any consequence of its use. Publication thereof does not convey nor imply any license under patent- or other industrial or intellectual property rights.

Printed in The Netherlands

417067/1200/03/pp28

Date of release: 1997 Mar 25

Document order number: 9397 750 01652

Let's make things better.

**Philips
Semiconductors**



PHILIPS