

SN75154 QUADRUPLE LINE RECEIVER

SLLS083B – NOVEMBER 1970 – REVISED MAY 1995

- Meets or Exceeds the Requirements of ANSI Standard EIA/TIA-232-E and ITU Recommendation V.28
- Input Resistance . . . 3 k Ω to 7 k Ω Over Full EIA/TIA-232-E Voltage Range
- Input Threshold Adjustable to Meet Fail-Safe Requirements Without Using External Components
- Built-In Hysteresis for Increased Noise Immunity
- Inverting Output Compatible With TTL
- Output With Active Pullup for Symmetrical Switching Speeds
- Standard Supply Voltages . . . 5 V or 12 V

D OR N PACKAGE
(TOP VIEW)

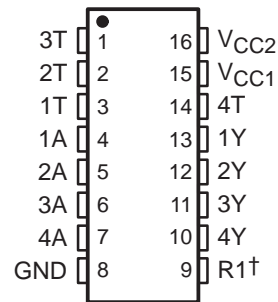

† For function of R1, see schematic

description

The SN75154 is a monolithic low-power Schottky line receiver designed to satisfy the requirements of the standard interface between data terminal equipment and data communication equipment as defined by ANSI Standard EIA/TIA-232-E. Other applications are for relatively short, single-line, point-to-point data transmission and for level translators. Operation is normally from a single 5-V supply; however, a built-in option allows operation from a 12-V supply without the use of additional components. The output is compatible with most TTL circuits when either supply voltage is used.

In normal operation, the threshold-control terminals are connected to the V_{CC1} terminal, even if power is being supplied via the alternate V_{CC2} terminal. This provides a wide hysteresis loop, which is the difference between the positive-going and negative-going threshold voltages. See typical characteristics. In this mode of operation, if the input voltage goes to zero, the output voltage will remain at the low or high level as determined by the previous input.

For fail-safe operation, the threshold-control terminals are open. This reduces the hysteresis loop by causing the negative-going threshold voltage to be above zero. The positive-going threshold voltage remains above zero as it is unaffected by the disposition of the threshold terminals. In the fail-safe mode, if the input voltage goes to zero or an open-circuit condition, the output will go to the high level regardless of the previous input condition.

The SN75154 is characterized for operation from 0°C to 70°C.



Please be aware that an important notice concerning availability, standard warranty, and use in critical applications of Texas Instruments semiconductor products and disclaimers thereto appears at the end of this data sheet.

PRODUCTION DATA information is current as of publication date. Products conform to specifications per the terms of Texas Instruments standard warranty. Production processing does not necessarily include testing of all parameters.

 **TEXAS
INSTRUMENTS**

POST OFFICE BOX 655303 • DALLAS, TEXAS 75265

Copyright © 1995, Texas Instruments Incorporated

SN75154 QUADRUPLE LINE RECEIVER

SLLS083B – NOVEMBER 1970 – REVISED MAY 1995

logic symbol†

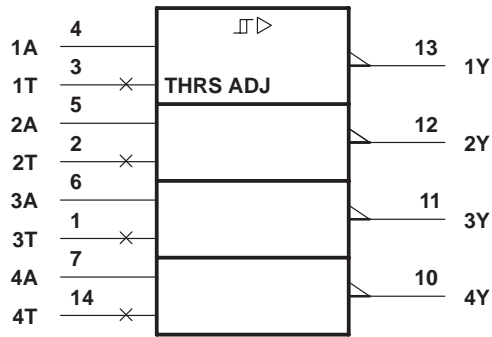

logic diagram (positive logic)

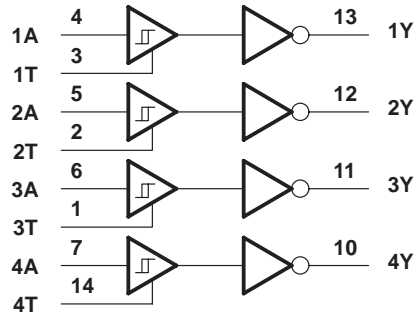

† This symbol is in accordance with ANSI/IEEE Std 91-1984 and IEC Publication 617-12.

schematic

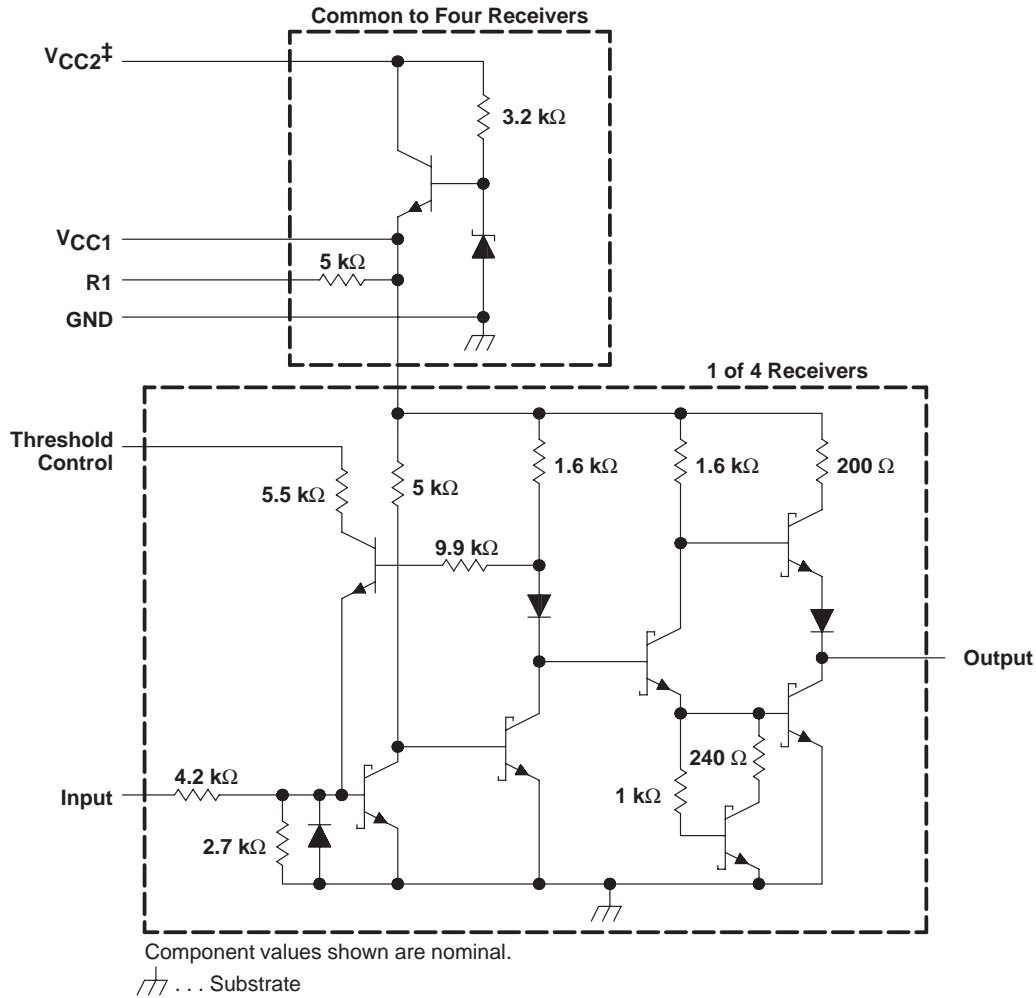

‡ When V_{CC1} is used, V_{CC2} may be left open or shorted to V_{CC1} . When V_{CC2} is used, V_{CC1} must be left open or connected to the threshold control pins.

SN75154 QUADRUPLE LINE RECEIVER

SLLS083B – NOVEMBER 1970 – REVISED MAY 1995

absolute maximum ratings over operating free-air temperature range (unless otherwise noted)†

Normal supply voltage, V_{CC1} (see Note 1)	7 V
Alternate supply voltage, V_{CC2}	14 V
Input voltage, V_I	± 25 V
Continuous total power dissipation	See Dissipation Rating Table
Operating free-air temperature range, T_A	0°C to 70°C
Storage temperature range, T_{stg}	-65°C to 150°C
Lead temperature 1,6 mm (1/16 inch) from case for 10 seconds	260°C

† Stresses beyond those listed under “absolute maximum ratings” may cause permanent damage to the device. These are stress ratings only, and functional operation of the device at these or any other conditions beyond those indicated under “recommended operating conditions” is not implied. Exposure to absolute-maximum-rated conditions for extended periods may affect device reliability.

NOTE 1: Voltage values are with respect to network GND terminal.

DISSIPATION RATING TABLE

PACKAGE	$T_A \leq 25^\circ\text{C}$ POWER RATING	DERATING FACTOR ABOVE $T_A = 25^\circ\text{C}$	$T_A = 70^\circ\text{C}$ POWER RATING
D	950 mW	7.6 mW/ $^\circ\text{C}$	608 mW
N	1150 mW	9.2 mW/ $^\circ\text{C}$	736 mW
NS	625 mW	5.0 mW/ $^\circ\text{C}$	400 mW

recommended operating conditions

	MIN	NOM	MAX	UNIT
Normal supply voltage, V_{CC1}	4.5	5	5.5	V
Alternate supply voltage, V_{CC2}	10.8	12	13.2	V
High-level input voltage, V_{IH} (see Note 2)	3		15	V
Low-level input voltage, V_{IL} (see Note 2)	-15		-3	V
High-level output current, I_{OH}			-400	μA
Low-level output current, I_{OL}			16	mA
Operating free-air temperature, T_A	0		70	$^\circ\text{C}$

NOTE 2: The algebraic convention, where the less positive (more negative) limit is designated as minimum, is used in this data sheet for logic and threshold levels only, e.g., when 0 V is the maximum, the minimum limit is a more negative voltage.

SN75154 QUADRUPLE LINE RECEIVER

SLLS083B – NOVEMBER 1970 – REVISED MAY 1995

electrical characteristics over recommended operating free-air temperature range (unless otherwise noted)

PARAMETER		TEST FIGURE	TEST CONDITIONS	MIN	TYP†	MAX	UNIT
V _{IT+}	Positive-going input threshold voltage	Normal operation	1	0.8	2.2	3	V
		Fail-safe operation		0.8	2.2	3	
V _{IT-}	Negative-going input threshold voltage	Normal operation	1	-3	-1.1	0	V
		Fail-safe operation		0.8	1.4	3	
V _{hys}	Hysteresis voltage (V _{IT+} - V _{IT-})	Normal operation	1	0.8	3.3	6	V
		Fail-safe operation		0	0.8	2.2	
V _{OH}	High-level output voltage	1	I _{OH} = -400 μA	2.4	3.5		V
V _{OL}	Low-level output voltage	1	I _{OL} = 16 mA		0.29	0.4	V
r _i	Input resistance	2	ΔV _I = -25 V to -14 V	3	5	7	kΩ
			ΔV _I = -14 V to -3 V	3	5	7	
			ΔV _I = -3 V to 3 V	3	6	8	
			ΔV _I = 3 V to 14 V	3	5	7	
			ΔV _I = 14 V to 25 V	3	5	7	
V _{I(open)}	Open-circuit input voltage	3	I _I = 0	0	0.2	2	V
I _{OS}	Short-circuit output current‡	4	V _{CC1} = 5.5 V, V _I = -5 V	-10	-20	-40	mA
I _{CC1}	Supply current from V _{CC1}	5	V _{CC1} = 5.5 V, T _A = 25°C		20	35	mA
I _{CC2}	Supply current from V _{CC2}		V _{CC2} = 13.2 V, T _A = 25°C		23	40	

† All typical values are at V_{CC1} = 5 V, T_A = 25°C.

‡ Not more than one output should be shorted at a time.

switching characteristics, V_{CC1} = 5 V, T_A = 25°C, N = 10

PARAMETER		TEST FIGURE	TEST CONDITIONS	MIN	TYP	MAX	UNIT
t _{PLH}	Propagation delay time, low- to high-level output	6	C _L = 50 pF, R _L = 390 Ω		11		ns
t _{PHL}	Propagation delay time, high- to low-level output				8		ns
t _{TLH}	Transition time, low- to high-level output				7		ns
t _{THL}	Transition time, high- to low-level output				2.2		ns



TYPICAL CHARACTERISTICS

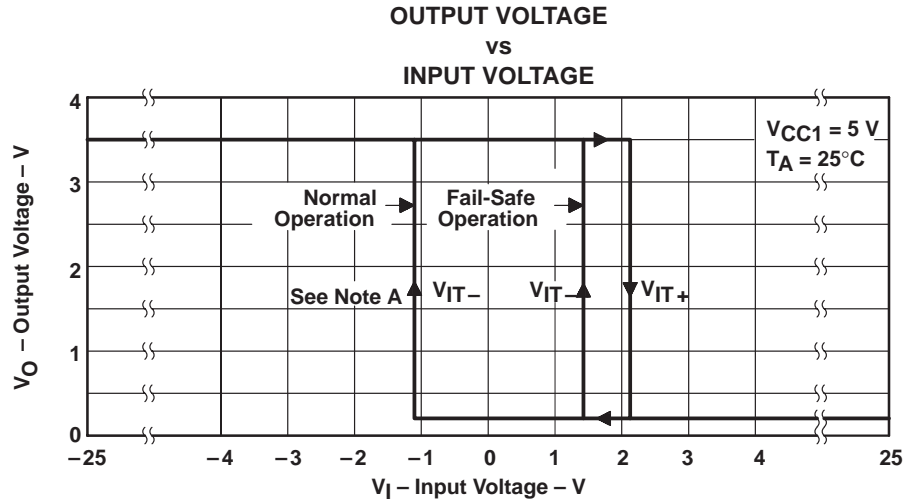

NOTE A: For normal operation, the threshold controls are connected to V_{CC1} . For fail-safe operation, the threshold controls are open.

Figure 1

SN75154 QUADRUPLE LINE RECEIVER

SLLS083B – NOVEMBER 1970 – REVISED MAY 1995

PARAMETER MEASUREMENT INFORMATION

dc test circuits†

TEST TABLE

TEST	MEASURE	A	T	Y	V _{CC1}	V _{CC2}
Open-circuit input (fail safe)	V _{OH}	Open	Open	I _{OH}	4.5 V	Open
	V _{OH}	Open	Open	I _{OH}	Open	10.8 V
V _{IT+} min, V _{IT-} min (fail safe)	V _{OH}	0.8 V	Open	I _{OH}	5.5 V	Open
	V _{OH}	0.8 V	Open	I _{OH}	Open	13.2 V
V _{IT+} min (normal)	V _{OH}	Note A	V _{CC1}	I _{OH}	5.5 V and T	Open
	V _{OH}	Note A	V _{CC1}	I _{OH}	T	13.2 V
V _{IL} max, V _{IT+} min (normal)	V _{OH}	-3 V	V _{CC1}	I _{OH}	5.5 V and T	Open
	V _{OH}	-3 V	V _{CC1}	I _{OH}	T	13.2 V
V _{IH} min, V _{IT+} max, V _{IT-} max (fail safe)	V _{OL}	3 V	Open	I _{OL}	4.5 V	Open
	V _{OL}	3 V	Open	I _{OL}	Open	10.8 V
V _{IH} min, V _{IT+} max (normal)	V _{OL}	3 V	V _{CC1}	I _{OL}	4.5 V and T	Open
	V _{OL}	3 V	V _{CC1}	I _{OL}	T	10.8 V
V _{IT-} max (normal)	V _{OL}	Note B	V _{CC1}	I _{OL}	5.5 V and T	Open
	V _{OL}	Note B	V _{CC1}	I _{OL}	T	13.2 V

NOTES: A. Momentarily apply -5 V, then 0.8 V.
B. Momentarily apply 5 V, then GND.

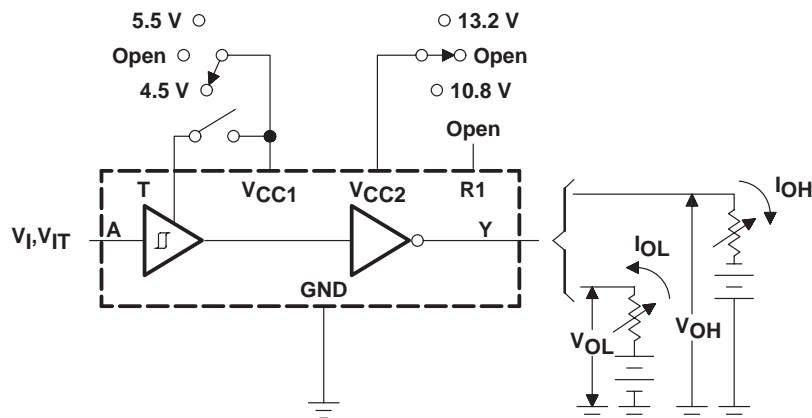
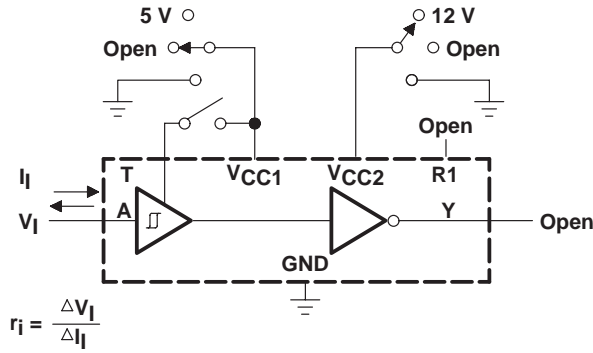

Figure 2. V_{IH}, V_{IL}, V_{IT+}, V_{IT-}, V_{OH}, V_{OL}

† Arrows indicate actual direction of current flow. Current into a terminal is a positive value.

PARAMETER MEASUREMENT INFORMATION

dc test circuits† (continued)



TEST TABLE		
T	V _{CC1}	V _{CC2}
Open	5 V	Open
Open	GND	Open
Open	Open	Open
V _{CC1}	T and 5 V	Open
GND	GND	Open
Open	Open	12 V
Open	Open	GND
V _{CC1}	T	12 V
V _{CC1}	T	GND
V _{CC1}	T	Open

Figure 3. Input Resistance

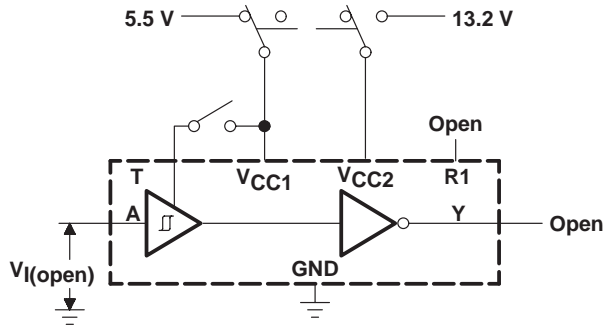

TEST TABLE		
T	V _{CC1}	V _{CC2}
Open	5.5 V	Open
V _{CC1}	5.5 V	Open
Open	Open	13.2 V
V _{CC1}	T	13.2 V

Figure 4. Input Voltage (Open)

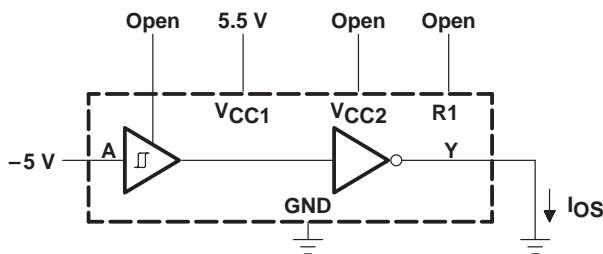

Each output is tested separately.

Figure 5. Output Short-Circuit Current

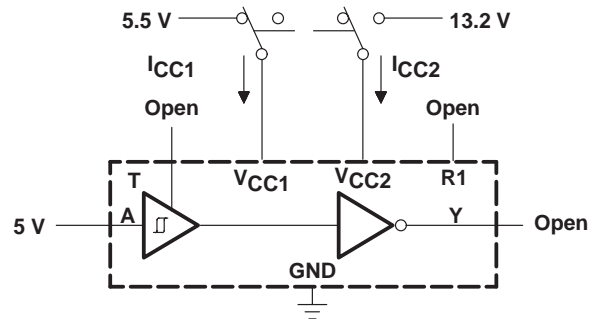

All four line receivers are tested simultaneously.

Figure 6. Supply Current

† Arrows indicate actual direction of current flow. Current into a terminal is a positive value.

SN75154 QUADRUPLE LINE RECEIVER

SLLS083B – NOVEMBER 1970 – REVISED MAY 1995

PARAMETER MEASUREMENT INFORMATION

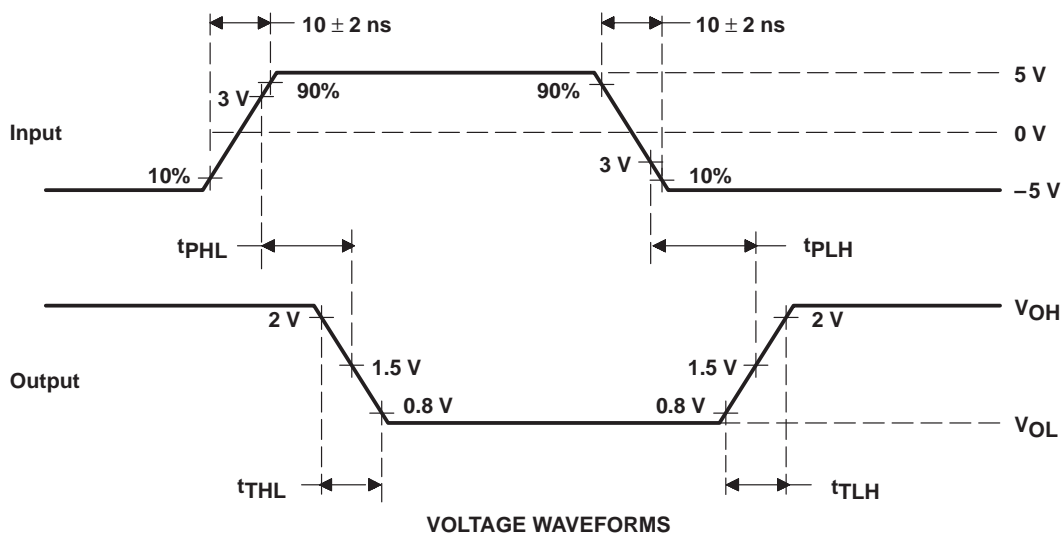
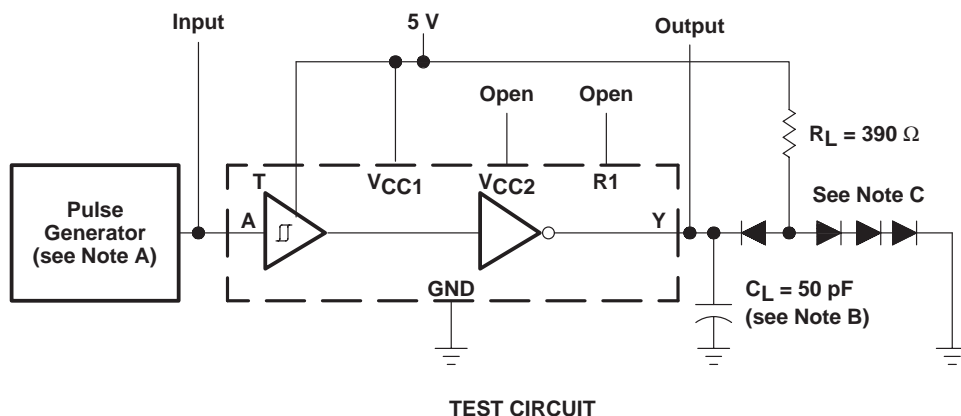

- NOTES: A. The pulse generator has the following characteristics: $Z_O = 50 \Omega$, $t_w \leq 200 \text{ ns}$, duty cycle $\leq 20\%$.
 B. C_L includes probe and jig capacitance.
 C. All diodes are 1N3064.

Figure 6. Test Circuit and Voltage Waveforms

IMPORTANT NOTICE

Texas Instruments and its subsidiaries (TI) reserve the right to make changes to their products or to discontinue any product or service without notice, and advise customers to obtain the latest version of relevant information to verify, before placing orders, that information being relied on is current and complete. All products are sold subject to the terms and conditions of sale supplied at the time of order acknowledgement, including those pertaining to warranty, patent infringement, and limitation of liability.

TI warrants performance of its semiconductor products to the specifications applicable at the time of sale in accordance with TI's standard warranty. Testing and other quality control techniques are utilized to the extent TI deems necessary to support this warranty. Specific testing of all parameters of each device is not necessarily performed, except those mandated by government requirements.

CERTAIN APPLICATIONS USING SEMICONDUCTOR PRODUCTS MAY INVOLVE POTENTIAL RISKS OF DEATH, PERSONAL INJURY, OR SEVERE PROPERTY OR ENVIRONMENTAL DAMAGE ("CRITICAL APPLICATIONS"). TI SEMICONDUCTOR PRODUCTS ARE NOT DESIGNED, AUTHORIZED, OR WARRANTED TO BE SUITABLE FOR USE IN LIFE-SUPPORT DEVICES OR SYSTEMS OR OTHER CRITICAL APPLICATIONS. INCLUSION OF TI PRODUCTS IN SUCH APPLICATIONS IS UNDERSTOOD TO BE FULLY AT THE CUSTOMER'S RISK.

In order to minimize risks associated with the customer's applications, adequate design and operating safeguards must be provided by the customer to minimize inherent or procedural hazards.

TI assumes no liability for applications assistance or customer product design. TI does not warrant or represent that any license, either express or implied, is granted under any patent right, copyright, mask work right, or other intellectual property right of TI covering or relating to any combination, machine, or process in which such semiconductor products or services might be or are used. TI's publication of information regarding any third party's products or services does not constitute TI's approval, warranty or endorsement thereof.