

TOSHIBA BIPOLAR LINEAR INTEGRATED CIRCUIT SILICON MONOLITHIC

# TA8428K(S), TA8428F

## FULL BRIDGE DRIVER

The TA8428K (S), TA8428F is Full Bridge Driver IC for Brush Motor Rotation Control.

Forward Rotation, Reverse Rotation, Stop and Braking operations are available.

Thermal Shutdown and Short Current Protector are provided.

### FEATURES

- Output Current : TA8428K (S) 1.5 A (AVE.), 3.0 A (PEAK)  
TA8428F 0.8 A (AVE.), 2.4 A (PEAK)
- 4 modes (forward / reverse / short brake and stop) are available with 2 TTL compatible inputs control.
- Free wheeling diodes are equipped.
- Multi protection system driver  
(Thermal shutdown and short current protector)

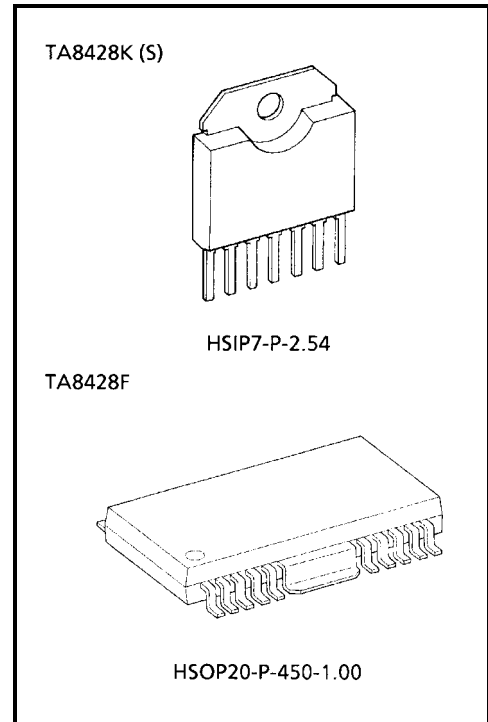

Weight

HSIP7-P-2.54 : 1.88 g (Typ.)

HSOP20-P-450-1.00 : 0.79 g (Typ.)

## BLOCK DIAGRAM

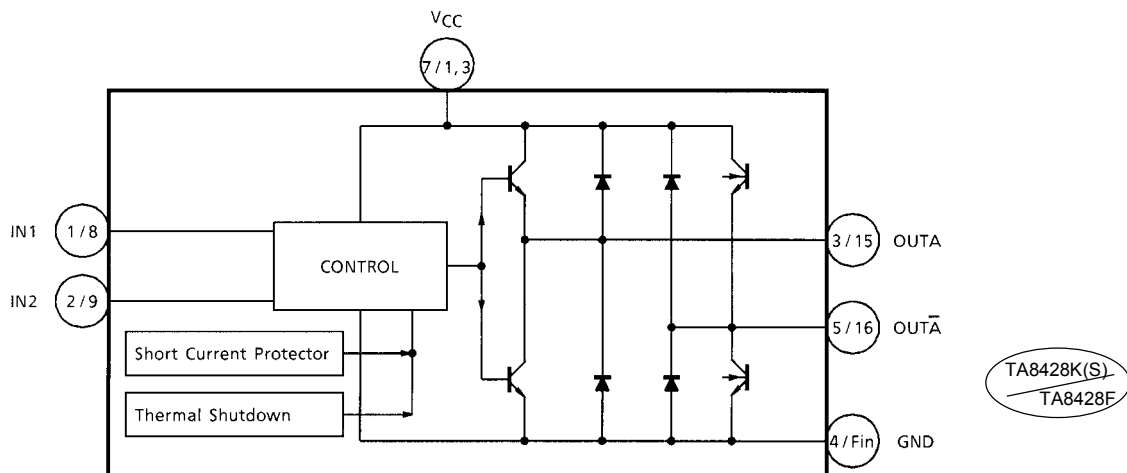

TA8428K(S)  
TA8428F

## PIN FUNCTION

PIN No.		SYMBOL	FUNCTIONAL DESCRIPTION
K(S)	F		
1	8	IN 1	TTL compatible control inputs.
2	9	IN 2	(PNP type low active comparator inputs)
3	15	OUTA	Output terminals and free wheeling diodes are connected between each output to GND and V <sub>CC</sub> .
4	Fin	GND	GND terminal
5	16	OUT $\bar{A}$	Output terminals and free wheeling diodes are connected between each output to GND and V <sub>CC</sub> .
6	Other pin	N.C	Non connection
7	1, 3	V <sub>CC</sub>	Supply voltage terminal for control and motor drive.

TA8428K (S), TA8428F has 2 build-in protective functions which work independently. These circuit operations are as follows.

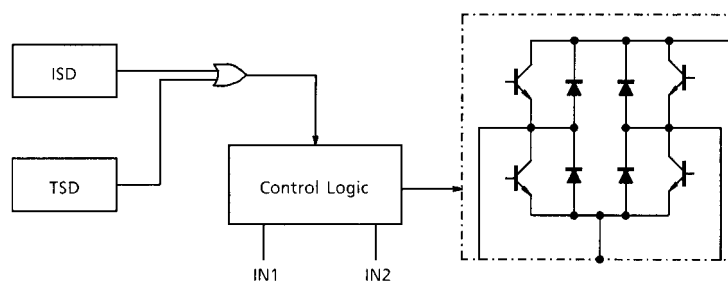

- Thermal shutdown (TSD)

If junction temperature of TA8428K (S), TA8428F is over the specified temperature (150°C Typ.) by excess power dissipation or abnormal ambient temperature change, thermal Shutdown circuit turn "ON" and output 4 transistors become High impedance. (All transistors turn "OFF")

- Short current protector (ISD)

Short current protector circuit senses all output transistor current. If output transistor current is over the specified limiting current value (2.0~3.0 A Typ.), short current protector operates and all output transistors periodically turn "OFF" (High Impedance Mode) in a period of approximately 80  $\mu$ s. This state is continued until the release of over current mode.

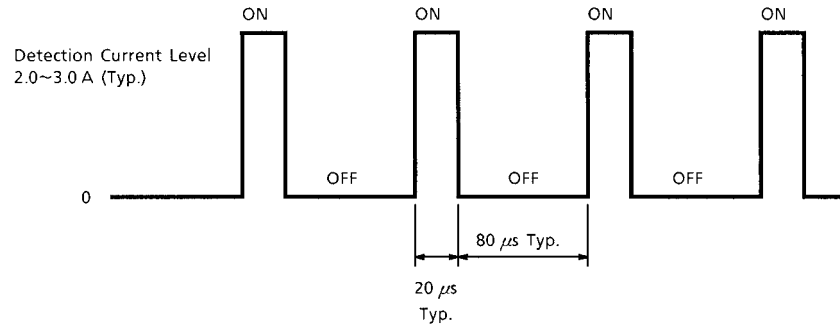

## INTERNAL CIRCUIT

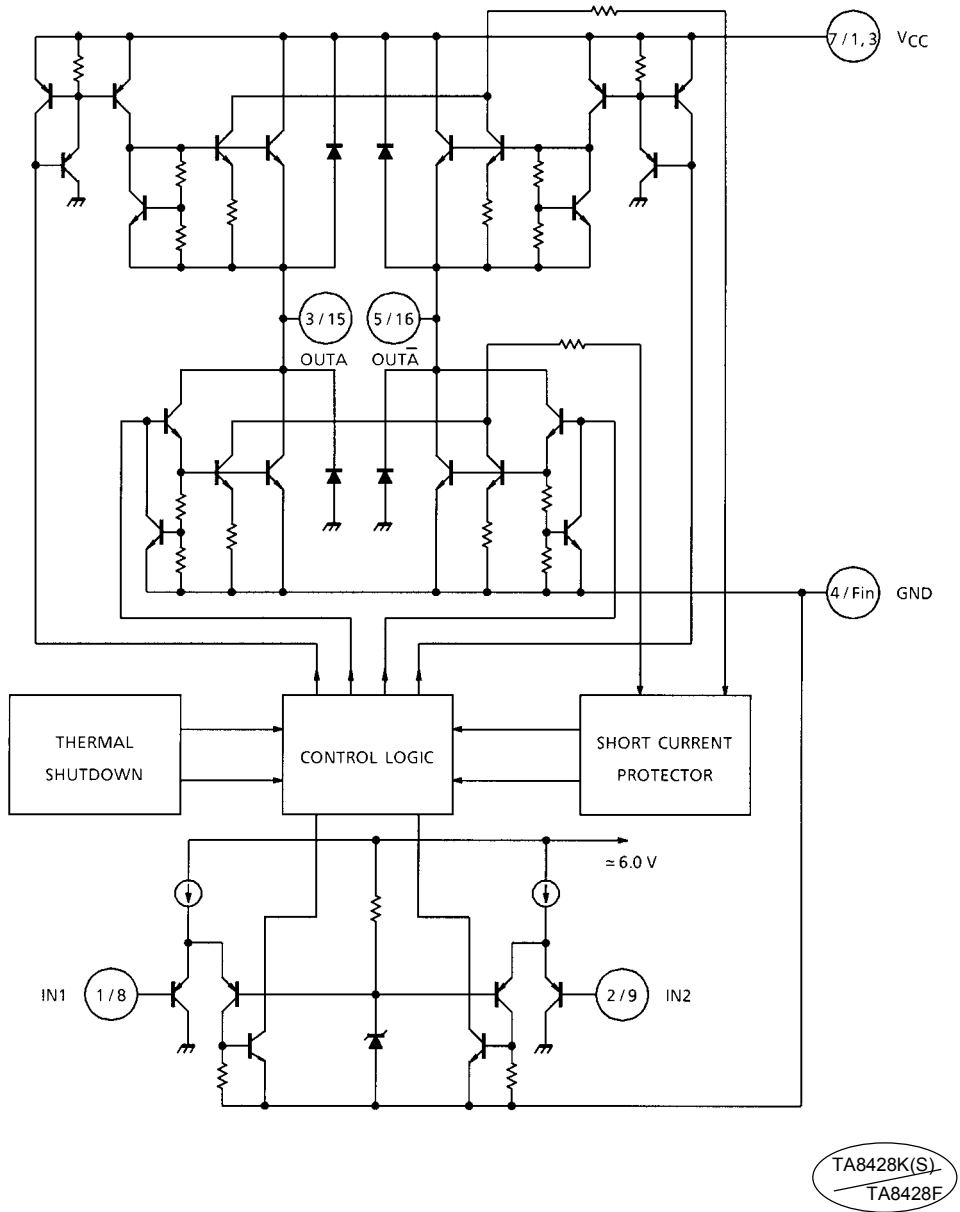

## MAXIMUM RATINGS (Ta = 25°C)

CHARACTERISTIC		SYMBOL	RATING	UNIT
Supply Voltage		V <sub>CC</sub>	30	V
Input Voltage		V <sub>IN</sub>	-0.3~V <sub>CC</sub>	V
Output Current	K (S) type	PEAK	I <sub>O</sub> (PEAK)	3.0 (Note 1)
		AVE.	I <sub>O</sub> (AVE.)	1.5
	F type	PEAK	I <sub>O</sub> (PEAK)	2.4 (Note 1)
		AVE.	I <sub>O</sub> (AVE.)	0.8
Power Dissipation	K (S) type	P <sub>D</sub>	1.25 (Note 2)	W
			10.0 (Note 3)	
	F type	P <sub>D</sub>	1.9 (Note 4)	
			2.5 (Note 5)	
Operating Temperature		T <sub>opr</sub>	-30~85	°C
Storage Temperature		T <sub>stg</sub>	-55~150	°C

Note 1: t = 100 ms

Note 2: No heat sink

Note 3: T<sub>c</sub> = 85°C

Note 4: This value is obtained by 30 × 30 × 1.6 mm PCB mounting occupied copper area in excess of 60%

Note 5: This value is obtained by 50 × 50 × 1.6 mm PCB mounting occupied copper area in excess of 60%

## ELECTRICAL CHARACTERISTICS (V<sub>CC</sub> = 24 V, Ta = 25°C)

CHARACTERISTIC		SYMBOL	TEST CIR-CUIT	Test Condition	MIN	TYP.	MAX	UNIT
Quiescent Current		I <sub>CC1</sub>	1	Stop mode	—	8	15	mA
		I <sub>CC2</sub>		Forward / reverse mode	—	35	85	
		I <sub>CC3</sub>		Brake mode	—	16	30	
Input Voltage		V <sub>IL</sub>	2	—	—	—	0.8	V
		V <sub>IH</sub>		—	2.0	—	—	
Input Current		I <sub>IL</sub>	2	V <sub>IN</sub> = GND	—	—	50	μA
		I <sub>IH</sub>		V <sub>IN</sub> = V <sub>CC</sub>	—	—	10	
Output Saturation Voltage	K (S) type	V <sub>sat</sub> (total)	3	I <sub>O</sub> = 1.5 A, T <sub>c</sub> = 25°C	—	2.2	2.9	V
	F type			I <sub>O</sub> = 0.8 A, T <sub>c</sub> = 25°C	—	1.8	2.5	
Output Leakage Current		I <sub>LU</sub>	4	V <sub>L</sub> = 25 V	—	—	50	μA
		I <sub>LL</sub>			—	—	50	
Diode Forward Voltage	K (S) type	I <sub>LU</sub>	4	I <sub>F</sub> = 1.5 A	—	2.6	—	V
		I <sub>LL</sub>			—	1.5	—	
	F type	I <sub>LU</sub>		I <sub>F</sub> = 0.8 A	—	2.2	—	
		I <sub>LL</sub>			—	1.2	—	
Thermal Shutdown Circuit Operating Temperature		T <sub>SD</sub>	—	—	—	150	—	°C
Propagation Delay Time		t <sub>pLH</sub>	2	—	—	1	—	μs
		t <sub>pHL</sub>	2	—	—	1	—	

## FUNCTION

INPUT		OUTPUT		RATING
IN1	IN2	OUTA	OUT $\bar{A}$	
H	H	L	L	Brake
L	H	L	H	CW / CCW
H	L	H	L	CCW / CW
L	L	OFF (high impedance)		Stop

Note: PIN (6) is non connection.

Note: Heat fin is connected with GND with low impedance.

## TEST CIRCUIT 1

$I_{CC1}$ ,  $I_{CC2}$ ,  $I_{CC3}$

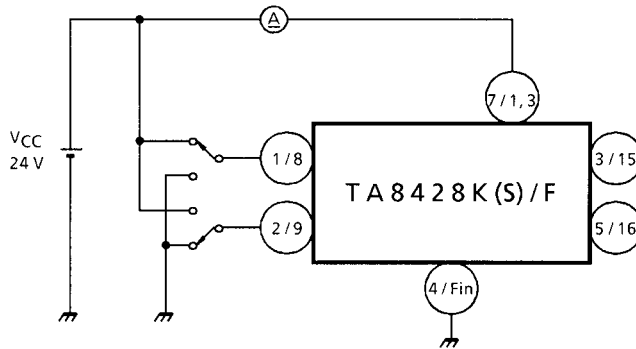

## TEST CIRCUIT 2

$V_{IL}$ ,  $V_{IH}$ ,  $I_{IL}$ ,  $I_{IH}$ ,  $t_{PLH}$ ,  $t_{PHL}$

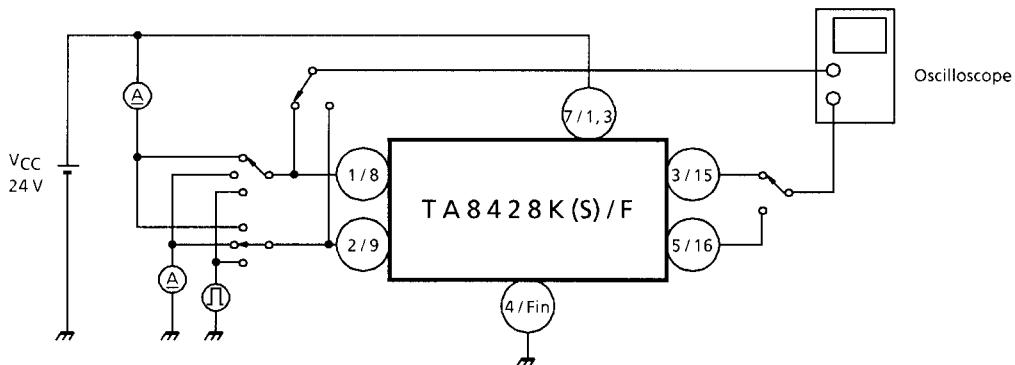

## TEST CIRCUIT 3

$V_{sat}$

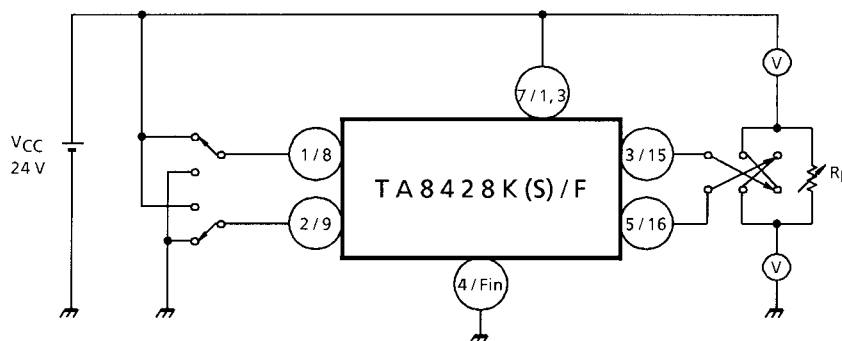

TA8428K(S)  
TA8428F

## TEST CIRCUIT 4

$I_{LH}$ ,  $I_{LL}$

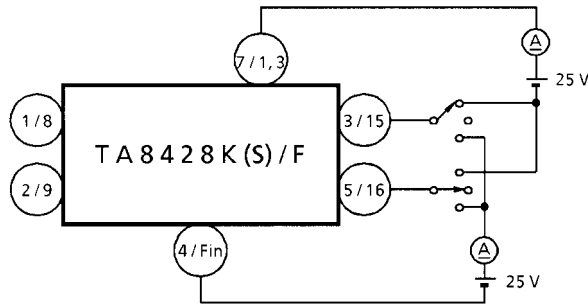

## TEST CIRCUIT 5

$V_{FU}$ ,  $V_{FL}$

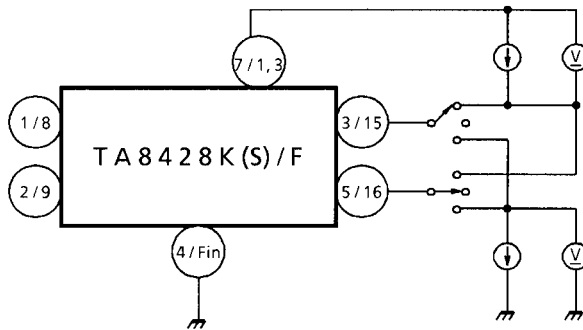

TA8428K(S)  
TA8428F

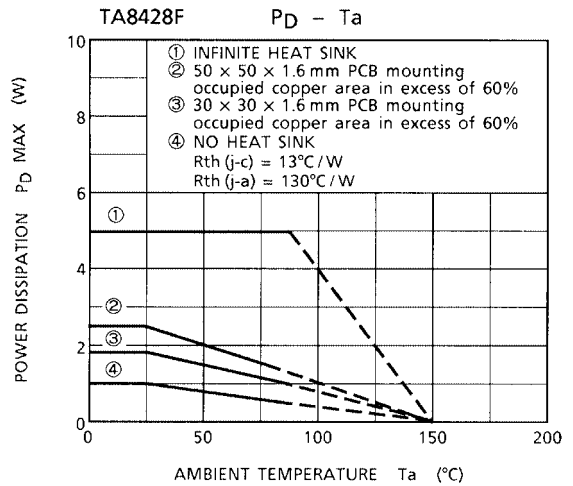
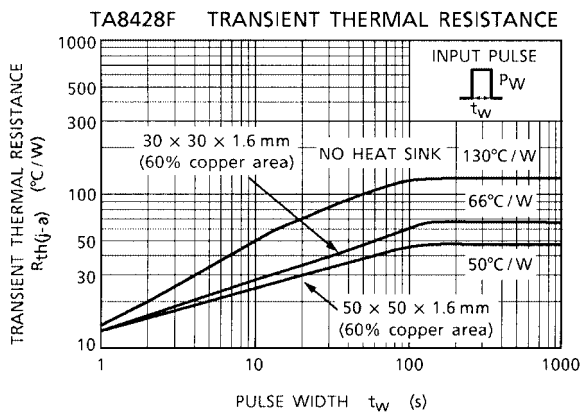
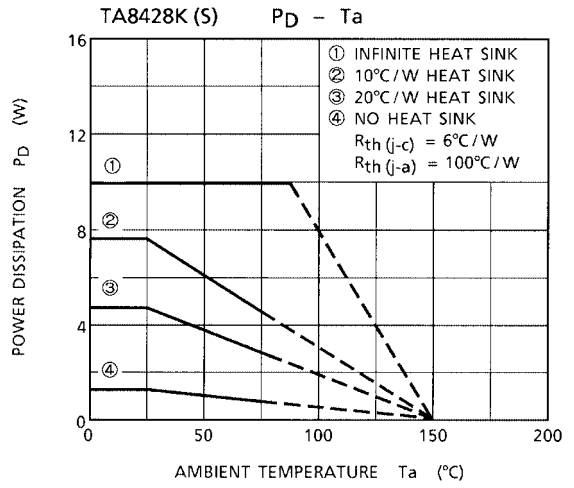
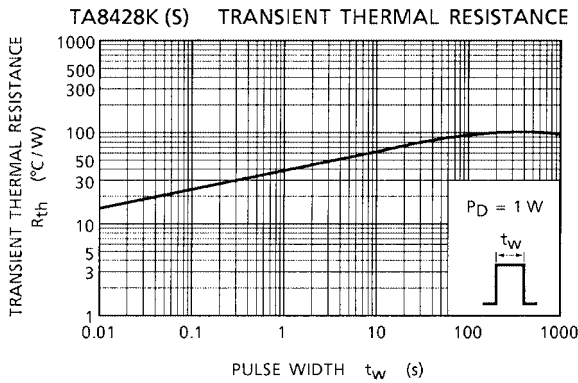
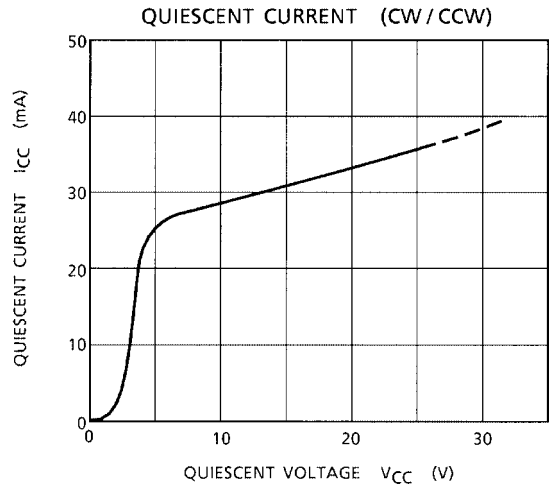
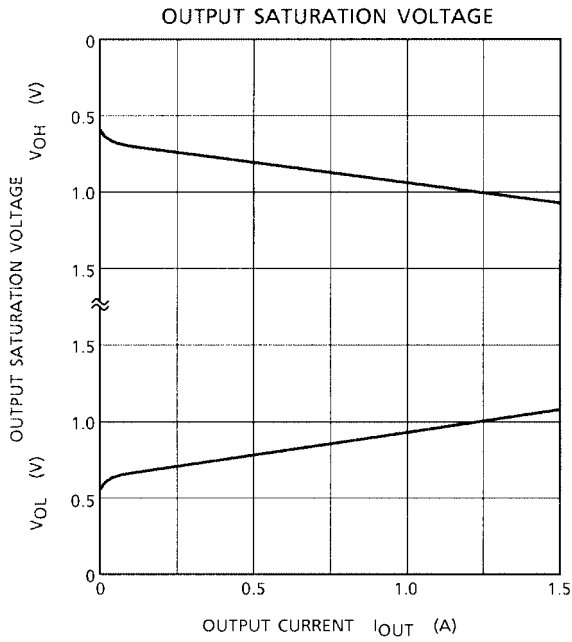



## APPLICATION CIRCUIT

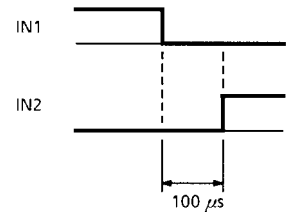
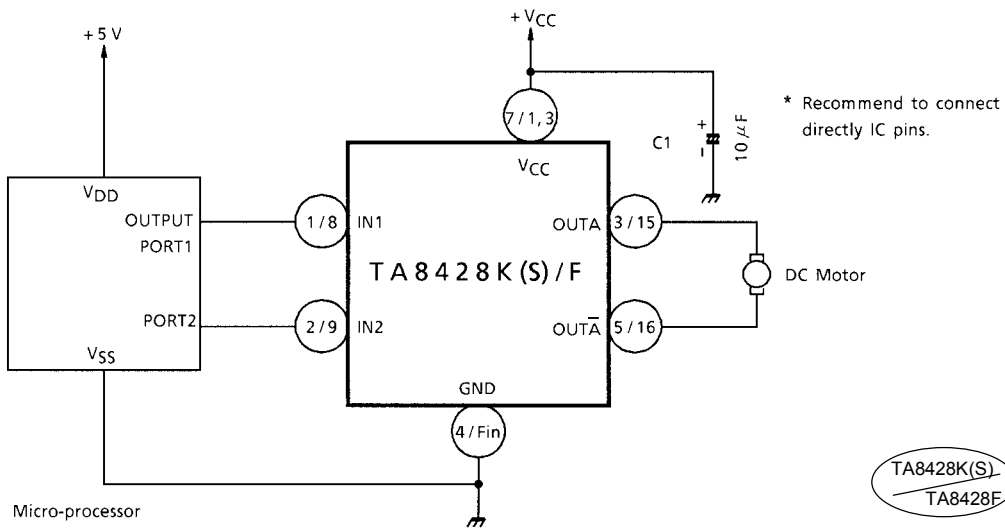

- Note: Recommend to take approximately 100  $\mu\text{s}$  of input dead time for reliable operations.
- Note: Utmost care is necessary in the design of the output line,  $V_{CC}$  and GND line since IC may be destroyed due to short-circuit between outputs, air contamination fault, or fault by improper grounding.
- Note: In case of mounted on radiators, do not use silicon rubber. (TA8428K (S))
- Note: Connect and use 1 pin and 3 pin surely. (TA8428F)

## PACKAGE DIMENSIONS

HSIP7-P-2.54

Unit : mm

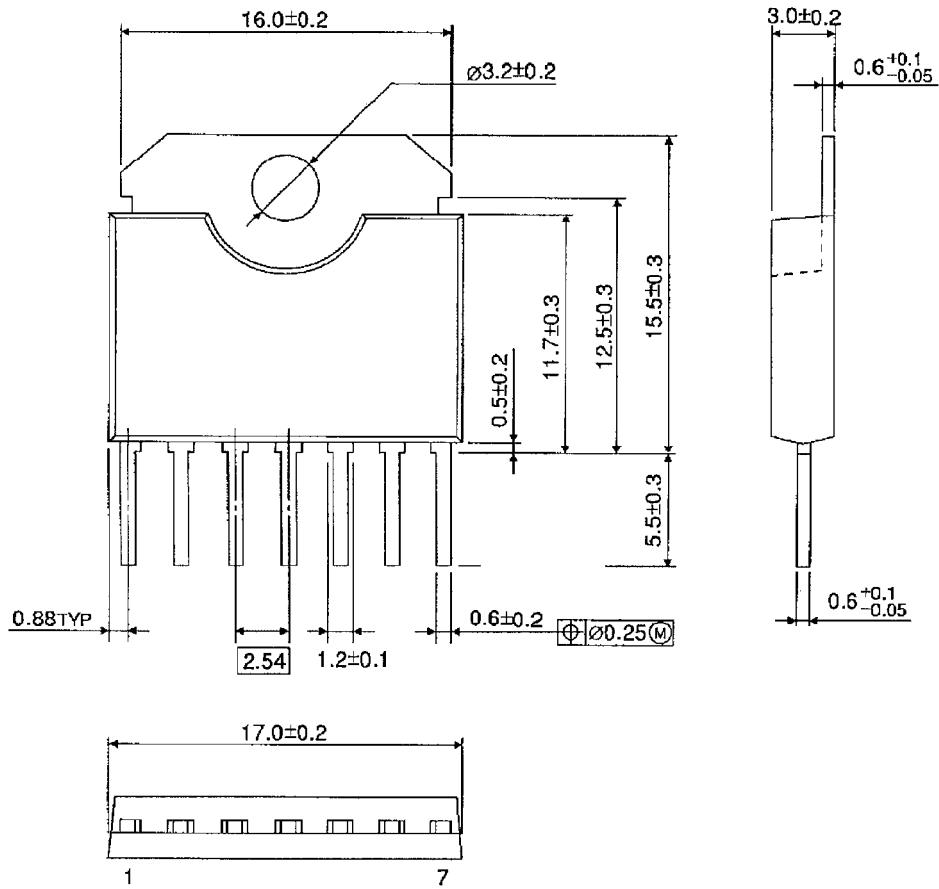

Weight : 1.88 g (Typ.)

## PACKAGE DIMENSIONS

HSOP20-P-450-1.00

Unit : mm

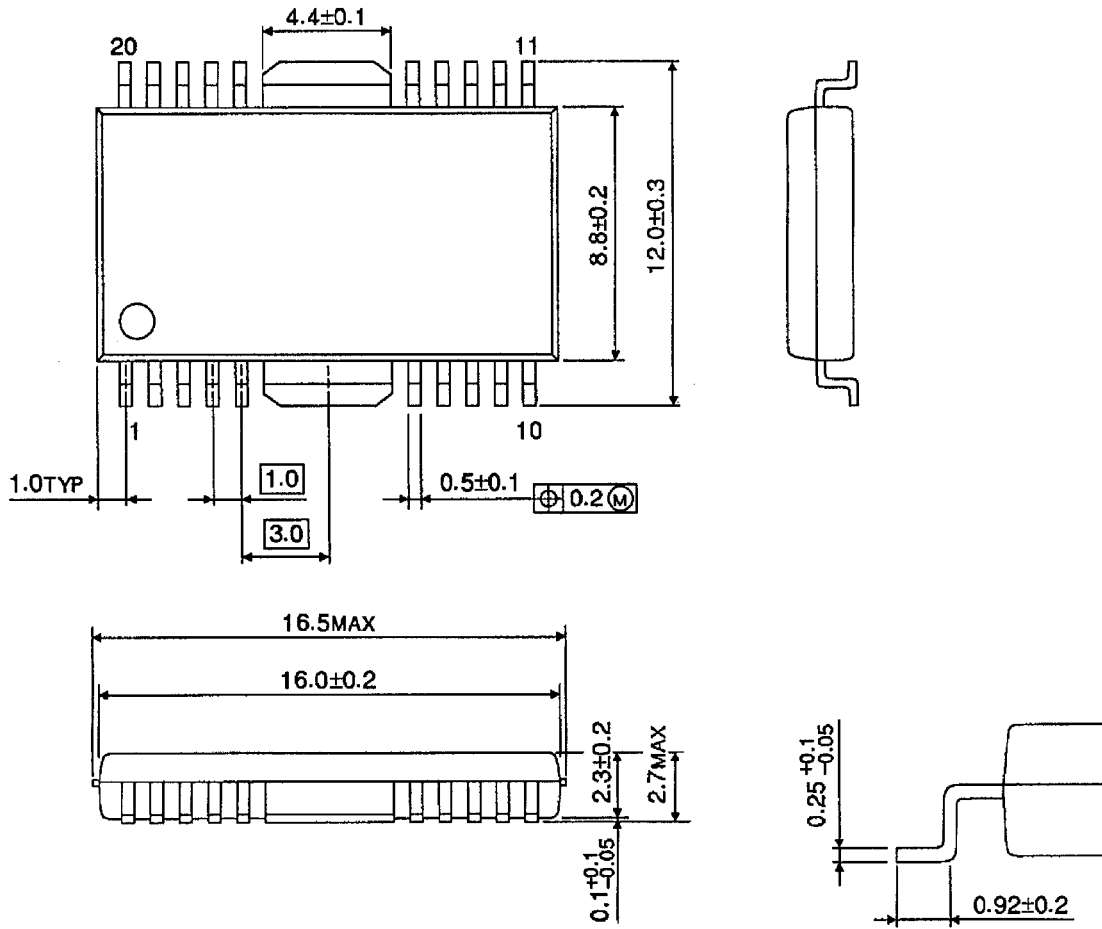

Weight : 0.79 g (Typ.)

**RESTRICTIONS ON PRODUCT USE**

000707EBA

- TOSHIBA is continually working to improve the quality and reliability of its products. Nevertheless, semiconductor devices in general can malfunction or fail due to their inherent electrical sensitivity and vulnerability to physical stress. It is the responsibility of the buyer, when utilizing TOSHIBA products, to comply with the standards of safety in making a safe design for the entire system, and to avoid situations in which a malfunction or failure of such TOSHIBA products could cause loss of human life, bodily injury or damage to property.  
In developing your designs, please ensure that TOSHIBA products are used within specified operating ranges as set forth in the most recent TOSHIBA products specifications. Also, please keep in mind the precautions and conditions set forth in the "Handling Guide for Semiconductor Devices," or "TOSHIBA Semiconductor Reliability Handbook" etc..
- The TOSHIBA products listed in this document are intended for usage in general electronics applications (computer, personal equipment, office equipment, measuring equipment, industrial robotics, domestic appliances, etc.). These TOSHIBA products are neither intended nor warranted for usage in equipment that requires extraordinarily high quality and/or reliability or a malfunction or failure of which may cause loss of human life or bodily injury ("Unintended Usage"). Unintended Usage include atomic energy control instruments, airplane or spaceship instruments, transportation instruments, traffic signal instruments, combustion control instruments, medical instruments, all types of safety devices, etc.. Unintended Usage of TOSHIBA products listed in this document shall be made at the customer's own risk.
- The products described in this document are subject to the foreign exchange and foreign trade laws.
- The information contained herein is presented only as a guide for the applications of our products. No responsibility is assumed by TOSHIBA CORPORATION for any infringements of intellectual property or other rights of the third parties which may result from its use. No license is granted by implication or otherwise under any intellectual property or other rights of TOSHIBA CORPORATION or others.
- The information contained herein is subject to change without notice.