



WIDEBAND, LOW NOISE, LOW DISTORTION FULLY DIFFERENTIAL AMPLIFIER

FEATURES

- Fully Differential Architecture
- Centered Input Common-mode Range
- Minimum Gain of 2V/V (6 dB)
- Bandwidth: 1900 MHz (100 mVpp, G = 10 dB, $R_L = 200 \Omega$)
- Slew Rate: 6600 V/ μ s (2V step, G = 10 dB)
- 1% Settling Time: 2 ns (2 V step, G = 10 dB)
- HD_2 : -75 dBc at 100 MHz (2 Vpp, G = 10 dB, $R_L = 1 k\Omega$)
- HD_3 : -80 dBc at 100 MHz (2 Vpp, G = 10 dB, $R_L = 1 k\Omega$)
- OIP_2 : 79 dBm at 70 MHz (2 Vpp envelope, G = 10 dB)
- OIP_3 : 43 dBm at 70 MHz (2 Vpp envelope, G = 10 dB)
- Input Voltage Noise: 1.9 nV/ \sqrt{Hz} (f >10 MHz)
- Noise Figure: 17.1 dB (50 Ω System, G = 10 dB)
- Output Common-Mode Control
- Power Supply:
 - Voltage: 3 V (± 1.5 V) to 5 V (± 2.5 V)
 - Current: 37.7 mA
- Power-Down Capability: 0.65 mA

APPLICATIONS

- 5 V Data Acquisition Systems High Linearity ADC Amplifier
- Wireless Communication
- Medical Imaging
- Test and Measurement

DESCRIPTION

The THS4509 is a wideband, fully differential op amp designed for 5 V data acquisition systems. It has very low noise at 1.9 nV/ \sqrt{Hz} , and extremely low harmonic distortion of -75 dBc HD_2 and -80 dBc HD_3 at 100 MHz with 2 Vpp, G = 10 dB, and 1 k Ω load. Slew rate is very high at 6600 V/ μ s and with settling time of 2 ns to 1% (2 V step) it is ideal for pulsed applications. It is designed for minimum gain of 6 dB, but is optimized for gain of 10 dB.

To allow for dc coupling to ADCs, its unique output common-mode control circuit maintains the output common-mode voltage within 3 mV offset (typ) from the set voltage, when set within 0.5 V of mid-supply, with less than 4 mV differential offset voltage. The common-mode set point is set to mid-supply by internal circuitry, which may be over-driven from an external source.

The input and output are optimized for best performance with their common-mode voltages set to mid-supply. Along with high performance at low power supply voltage, this makes for extremely high performance single supply 5 V data acquisition systems. The combined performance of the THS4509 in a gain of 10 dB driving the ADS5500 ADC, sampling at 125 MSPS, is 81 dBc SFDR and 69.1 dBc SNR with a -1 dBFS signal at 70 MHz.

The THS4509 is offered in a Quad 16-pin leadless QFN package (RGT), and is characterized for operation over the full industrial temperature range from -40°C to 85°C.

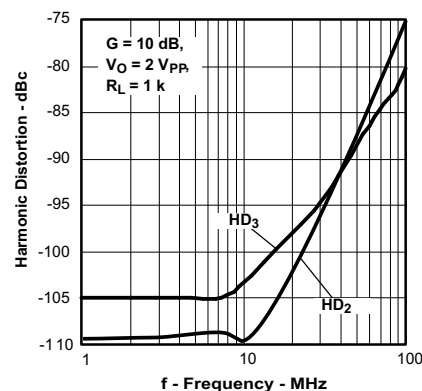
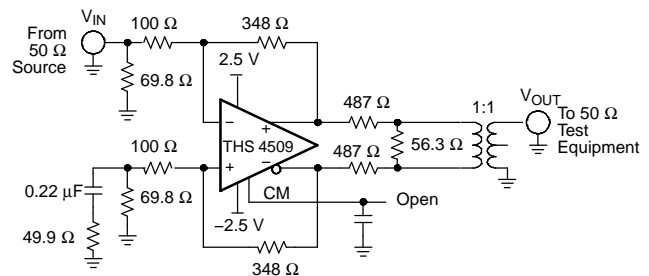

Please be aware that an important notice concerning availability, standard warranty, and use in critical applications of Texas Instruments semiconductor products and disclaimers thereto appears at the end of this data sheet.



This integrated circuit can be damaged by ESD. Texas Instruments recommends that all integrated circuits be handled with appropriate precautions. Failure to observe proper handling and installation procedures can cause damage.

ESD damage can range from subtle performance degradation to complete device failure. Precision integrated circuits may be more susceptible to damage because very small parametric changes could cause the device not to meet its published specifications.

PACKAGING/ORDERING INFORMATION

TEMPERATURE	PACKAGED DEVICES			SYMBOL
		QUAD QFN ⁽¹⁾⁽²⁾ (RGT-16)		
–40°C to 85°C		THS4509RGTT		–
		THS4509RGTR		

- (1) This package is available taped and reeled. The R suffix standard quantity is 3000. The T suffix standard quantity is 250.
- (2) The exposed thermal pad is electrically isolated from all other pins.

ABSOLUTE MAXIMUM RATINGS

over operating free-air temperature range (unless otherwise noted)

		UNIT
V _{S-} to V _{S+}	Supply voltage	6 V
V _I	Input voltage	±VS
V _{ID}	Differential input voltage	4 V
I _O	Output current ⁽¹⁾	200 mA
	Continuous power dissipation	See Dissipation Rating Table
T _J	Maximum junction temperature	150°C
T _A	Operating free-air temperature range	–40°C to 85°C
T _{stg}	Storage temperature range	–65°C to 150°C
	Lead temperature 1,6 mm (1/16 inch) from case for 10 seconds	300°C
ESD ratings	HBM	2000
	CDM	1500
	MM	100

- (1) The THS4509 incorporates a (QFN) exposed thermal pad on the underside of the chip. This acts as a heatsink and must be connected to a thermally dissipative plane for proper power dissipation. Failure to do so may result in exceeding the maximum junction temperature which could permanently damage the device. See TI technical brief [SLMA002](#) and [SLMA004](#) for more information about utilizing the QFN thermally enhanced package.

DISSIPATION RATINGS TABLE PER PACKAGE

PACKAGE	θ _{JC}	θ _{JA}	POWER RATING	
			T _A ≤ 25°C	T _A = 85°C
RGT (16)	2.4°C/W	39.5°C/W	2.3 W	225 mW

SPECIFICATIONS; $V_{S+} - V_{S-} = 5\text{ V}$:

Test conditions unless otherwise noted: $V_{S+} = +2.5\text{ V}$, $V_{S-} = -2.5\text{ V}$, CM = open, $V_O = 2\text{ Vpp}$, $R_F = 349\ \Omega$, $R_L = 200\ \Omega$
Differential, G = 10 dB, Single-Ended Input, Differential Output, Input and Output Referenced to Mid-supply

PARAMETER	TEST CONDITIONS	TYP	OVER TEMPERATURE				TEST LEVEL ⁽¹⁾
		25°C	25°C	-40°C to 85°C	UNITS	MIN/ MAX	
AC PERFORMANCE							
Small-Signal Bandwidth	G = 6 dB, $V_O = 100\text{ mVpp}$	2.0			GHz	Typ	C
	G = 10 dB, $V_O = 100\text{ mVpp}$	1.9			GHz	Typ	
	G = 14 dB, $V_O = 100\text{ mVpp}$	600			MHz	Typ	
	G = 20 dB, $V_O = 100\text{ mVpp}$	275			MHz	Typ	
Gain-Bandwidth Product	G = 20 dB	3			GHz	Typ	
Bandwidth for 0.1dB flatness	G = 10 dB, $V_O = 2\text{ Vpp}$	300			MHz	Typ	
Large-Signal Bandwidth	G = 10 dB, $V_O = 2\text{ Vpp}$	1.5			GHz	Typ	
Slew Rate (Differential)	2V Step	6600			V/ μ s	Typ	
Rise Time	2V Step	0.5			ns	Typ	
Fall Time	2V Step	0.5			ns	Typ	
Settling Time to 1%	$V_O = 2\text{ V Step}$	2			ns	Typ	
Settling Time to 0.1%	$V_O = 2\text{ V Step}$	10			ns	Typ	
2 nd Order Harmonic Distortion (Single-ended input)	f = 10 MHz	-104			dBc	Typ	
	f = 50 MHz	-80			dBc	Typ	
	f = 100 MHz	-68			dBc	Typ	
3 rd Order Harmonic Distortion (Single-ended input)	f = 10 MHz	-108			dBc	Typ	
	f = 50 MHz	-92			dBc	Typ	
	f = 100 MHz	-81			dBc	Typ	
2 nd Order Intermodulation Distortion (Single-ended input)	$V_O = 2\text{ Vpp envelope}$, 200 kHz Tone Spacing, $R_L = 499\ \Omega$	$f_C = 70\text{ MHz}$	-78		dBc	Typ	
		$f_C = 140\text{ MHz}$	-64		dBc	Typ	
3 rd Order Intermodulation Distortion (Single-ended input)		$f_C = 70\text{ MHz}$	-95		dBc	Typ	
		$f_C = 140\text{ MHz}$	-78		dBc	Typ	
2 nd Order Output Intercept Point (Single-ended input)	200 kHz Tone Spacing	$f_C = 70\text{ MHz}$	78		dBm	Typ	
		$f_C = 140\text{ MHz}$	58		dBm	Typ	
3 rd Order Output Intercept Point (Single-ended input)		$f_C = 70\text{ MHz}$	43		dBm	Typ	
		$f_C = 140\text{ MHz}$	38		dBm	Typ	
1-dB Compression Point ⁽²⁾	$f_C = 70\text{ MHz}$	12.2			dBm	Typ	
	$f_C = 140\text{ MHz}$	10.8					
Noise Figure	50 Ω System, 10 MHz	17.1			dB	Typ	
Input Voltage Noise	f > 10 MHz	1.9			nV/ $\sqrt{\text{Hz}}$	Typ	
Input Current Noise	f > 10 MHz	2.2			pA/ $\sqrt{\text{Hz}}$	Typ	
DC PERFORMANCE							
Open-Loop Voltage Gain (A_{OL})		68			dB	Typ	C
Input Offset Voltage		0.5	0.8	1	mV	Max	B
Average Offset Voltage Drift				2.6	$\mu\text{V}/^\circ\text{C}$	Typ	
Input Bias Current		6	8	13	μA	Max	A
Average Bias Current Drift				20	nA/ $^\circ\text{C}$	Typ	B
Input Offset Current		1.6	3.6	4.5	μA	Max	A
Average Offset Current Drift				4	nA/ $^\circ\text{C}$	Typ	B
INPUT							
Common-Mode Input Range High		1.75			V	Max	A
Common-Mode Input Range Low		-1.75			V	Min	
Common-Mode Rejection Ratio		90			dB	Min	B

(1) Test levels: (A) 100% tested at 25°C. Overtemperature limits by characterization and simulation. (B) Limits set by characterization and simulation. (C) Typical value only for information.

(2) The 1-dB compression point is measured at the load with 50- Ω double termination. Add 3 dB to refer to amplifier output.

SPECIFICATIONS; $V_{S+} - V_{S-} = 5\text{ V}$: (continued)

Test conditions unless otherwise noted: $V_{S+} = +2.5\text{ V}$, $V_{S-} = -2.5\text{ V}$, CM = open, $V_O = 2\text{ Vpp}$, $R_F = 349\ \Omega$, $R_L = 200\ \Omega$
Differential, G = 10 dB, Single-Ended Input, Differential Output, Input and Output Referenced to Mid-supply

PARAMETER	TEST CONDITIONS	TYP	OVER TEMPERATURE				
		25°C	25°C	-40°C to 85°C	UNITS	MIN/MAX	TEST LEVEL ⁽¹⁾
OUTPUT							
Maximum Output Voltage High	Each output with 100 Ω to mid-supply	1.4	1.35	1.13	V	Min	A
Minimum Output Voltage Low		-1.4	-1.35	-1.13	V	Max	
Differential Output Voltage Swing		5.6	5.4	4.5	V	Min	
Differential Output Current Drive	$R_L = 10\ \Omega$	96			mA	Typ	C
Output Balance Error	$V_O = 100\text{ mV}$, $f = 1\text{ MHz}$	-49			dB	Typ	
Closed-Loop Output Impedance	$f = 1\text{ MHz}$	0.3			Ω	Typ	
OUTPUT COMMON-MODE VOLTAGE CONTROL							
Small-Signal Bandwidth		700			MHz	Typ	C
Slew Rate		110			V/ μ s	Typ	
Gain		1			V/V	Typ	
Output Common-Mode Offset from CM input	$-1\text{ V} < \text{CM} < 1\text{ V}$	5			mV	Typ	
CM Input Bias Current	$-1\text{ V} < \text{CM} < 1\text{ V}$	± 40			μ A	Typ	
CM Input Voltage Range		-1.5 to 1.5			V	Typ	
CM Input Impedance		23 1			k Ω pF	Typ	
CM Default Voltage		0			V	Typ	
POWER SUPPLY							
Specified Operating Voltage		5	5.5	5.5	V	Max	C
Maximum Quiescent Current		37.7	38.6	38.7	mA	Max	A
Minimum Quiescent Current		37.7	36.4	36	mA	Min	
Power Supply Rejection (\pm PSRR)		90			dB	Min	C
POWERDOWN							
Enable Voltage Threshold	Referenced to V_{S-} , Device Assured <i>on</i> above 2.1 V	1.6			V	Min	C
Disable Voltage Threshold	Referenced to V_{S-} , Device Assured <i>off</i> below 0.7 V	1.6			V	Max	
Powerdown Quiescent Current		0.65	0.76	0.89	mA	Max	A
Input Bias Current	$\overline{\text{PD}} = V_{S-}$	100			μ A	Typ	C
Input Impedance		50 2			k Ω pF	Typ	
Turn-on Time Delay	Measured to output on	55			ns	Typ	
Turn-off Time Delay	Measured to output off	10			μ s	Typ	

SPECIFICATIONS; $V_{S+} - V_{S-} = 3\text{ V}$:

Test conditions unless otherwise noted: $V_{S+} = +1.5\text{ V}$, $V_{S-} = -1.5\text{ V}$, CM = open, $V_O = 1\text{ Vpp}$, $R_F = 349\ \Omega$, $R_L = 200\ \Omega$
Differential, G = 10 dB, Single-Ended Input, Differential Output, Input and Output Referenced to Mid-supply

PARAMETER	TEST CONDITIONS	TYP	OVER TEMPERATURE				TEST LEVEL ⁽¹⁾
		25°C	25°C	-40°C to 85°C	UNITS	MIN/MAX	
AC PERFORMANCE							
Small-Signal Bandwidth	G = 6 dB, $V_O = 100\text{ mVpp}$	1.9			GHz	Typ	C
	G = 10 dB, $V_O = 100\text{ mVpp}$	1.6			GHz	Typ	
	G = 14 dB, $V_O = 100\text{ mVpp}$	625			MHz	Typ	
	G = 20 dB, $V_O = 100\text{ mVpp}$	260			MHz	Typ	
Gain-Bandwidth Product	G = 20 dB	3			GHz	Typ	
Bandwidth for 0.1dB flatness	G = 10 dB, $V_O = 1\text{ Vpp}$	400			MHz	Typ	
Large-Signal Bandwidth	G = 10 dB, $V_O = 1\text{ Vpp}$	1.5			GHz	Typ	
Slew Rate (Differential)	1V Step	3500			V/ μs	Typ	
Rise Time	1V Step	0.25			ns	Typ	
Fall Time	1V Step	0.25			ns	Typ	
Settling Time to 1%	$V_O = 1\text{ V Step}$	1			ns	Typ	
2 nd Order Harmonic Distortion (Single-ended input)	f = 10 MHz	-107			dBc	Typ	
	f = 50 MHz	-83			dBc	Typ	
	f = 100 MHz	-60			dBc	Typ	
3 rd Order Harmonic Distortion (Single-ended input)	f = 10 MHz	-87			dBc	Typ	
	f = 50 MHz	-65			dBc	Typ	
	f = 100 MHz	-54			dBc	Typ	
2 nd Order Intermodulation Distortion (Single-ended input)	$V_O = 1\text{ Vpp envelope}$, 200 kHz Tone Spacing, $R_L = 200\ \Omega$	$f_C = 70\text{ MHz}$	-77		dBc	Typ	
		$f_C = 140\text{ MHz}$	-54		dBc	Typ	
3 rd Order Intermodulation Distortion (Single-ended input)		$f_C = 70\text{ MHz}$	-77		dBc	Typ	
		$f_C = 140\text{ MHz}$	-62		dBc	Typ	
2 nd Order Output Intercept Point (Single-ended input)	200 kHz Tone Spacing	$f_C = 70\text{ MHz}$	72		dBm	Typ	
		$f_C = 140\text{ MHz}$	52		dBm	Typ	
3 rd Order Output Intercept Point (Single-ended input)		$f_C = 70\text{ MHz}$	38.5		dBm	Typ	
		$f_C = 140\text{ MHz}$	30		dBm	Typ	
1-dB Compression Point ⁽²⁾		$f_C = 70\text{ MHz}$	2.2		dBm	Typ	
		$f_C = 140\text{ MHz}$	0.25				
Noise Figure	50 Ω System, 10 MHz	17.1			dB	Typ	
Input Voltage Noise	f > 10 MHz	1.9			nV/ $\sqrt{\text{Hz}}$	Typ	
Input Current Noise	f > 10 MHz	2.2			pA/ $\sqrt{\text{Hz}}$	Typ	
DC PERFORMANCE							
Open-Loop Voltage Gain (A_{OL})		68			dB	Typ	C
Input Offset Voltage		0.5	0.8	1	mV	Max	B
Average Offset Voltage Drift				2.6	$\mu\text{V}/^\circ\text{C}$	Typ	
Input Bias Current		6	8	13	μA	Max	A
Average Bias Current Drift				20	nA/ $^\circ\text{C}$	Typ	B
Input Offset Current		1.6	3.6	4.5	μA	Max	A
Average Offset Current Drift				4	nA/ $^\circ\text{C}$	Typ	B
INPUT							
Common-Mode Input Range High		0.75			V	Max	A
Common-Mode Input Range Low		-0.75			V	Min	
Common-Mode Rejection Ratio		80			dB	Min	B

(1) Test levels: (A) 100% tested at 25°C. Overtemperature limits by characterization and simulation. (B) Limits set by characterization and simulation. (C) Typical value only for information.

(2) The 1-dB compression point is measured at the load with 50- Ω double termination. Add 3 dB to refer to amplifier output.

SPECIFICATIONS; $V_{S+} - V_{S-} = 3\text{ V}$: (continued)

Test conditions unless otherwise noted: $V_{S+} = +1.5\text{ V}$, $V_{S-} = -1.5\text{ V}$, CM = open, $V_O = 1\text{ Vpp}$, $R_F = 349\ \Omega$, $R_L = 200\ \Omega$
Differential, G = 10 dB, Single-Ended Input, Differential Output, Input and Output Referenced to Mid-supply

PARAMETER	TEST CONDITIONS	TYP	OVER TEMPERATURE				TEST LEVEL ⁽¹⁾
		25°C	25°C	-40°C to 85°C	UNITS	MIN/MAX	
OUTPUT							
Maximum Output Voltage High	Each output with 100 Ω to mid-supply	0.45	0.43	0.2	V	Min	A
Minimum Output Voltage Low		-0.45	-0.43	-0.2	V	Max	
Differential Output Voltage Swing		1.8	1.65	0.8	V	Min	
Differential Output Current Drive	$R_L = 20\ \Omega$	20	18	18	mA	Min	
Output Balance Error	$V_O = 100\text{ mV}$, $f = 1\text{ MHz}$	-49			dB	Typ	C
Closed-Loop Output Impedance	$f = 1\text{ MHz}$	0.3			Ω	Typ	
OUTPUT COMMON-MODE VOLTAGE CONTROL							
Small-Signal Bandwidth		570			MHz	Typ	C
Slew Rate		60			V/ μ s	Typ	
Gain		1			V/V	Typ	
Output Common-Mode Offset from CM input	$-0.5\text{ V} < \text{CM} < 0.5\text{ V}$	4			mV	Typ	
CM Input Bias Current	$-0.5\text{ V} < \text{CM} < 0.5\text{ V}$	± 40			μ A	Typ	
CM Input Voltage Range		-1.5 to 1.5			V	Typ	
CM Input Impedance		20 1			k Ω pF	Typ	
CM Default Voltage		0			V	Typ	
POWER SUPPLY							
Specified Operating Voltage		3	5.5	5.5	V	Max	A
Maximum Quiescent Current		34.8	35.8	36	mA	Max	
Minimum Quiescent Current		34.8	33.8	33	mA	Min	
Power Supply Rejection (\pm PSRR)		78			dB	Min	C
POWERDOWN							
Enable Voltage Threshold	Referenced to V_{S-} Device Assured <i>on</i> above 2.1 V				V	Min	C
Disable Voltage Threshold	Referenced to V_{S-} Device Assured <i>off</i> below 0.7 V				V	Max	
Powerdown Quiescent Current		0.46	0.53	0.67	mA	Max	A
Input Bias Current	$\overline{\text{PD}} = V_{S-}$	65			μ A	Typ	C
Input Impedance		50 2			k Ω pF	Typ	
Turn-on Time Delay	Measured to output on	100			ns	Typ	
Turn-off Time Delay	Measured to output off	10			μ s	Typ	

DEVICE INFORMATION

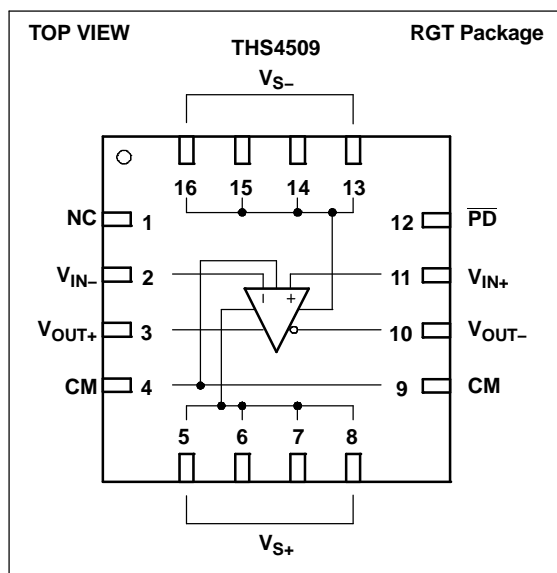

TERMINAL FUNCTIONS

TERMINAL (RGT PACKAGE)		DESCRIPTION
NO.	NAME	
1	NC	No internal connection
2	V_{IN-}	Inverting amplifier input
3	V_{OUT+}	Non-inverted amplifier output
4,9	CM	Common-mode voltage input
5,6,7,8	V_{S+}	Positive amplifier power supply input
10	V_{OUT-}	Inverted amplifier output
11	V_{IN+}	Non-inverting amplifier input
12	$\overline{P_D}$	Powerdown, $\overline{P_D}$ = logic low puts part into low power mode, $\overline{P_D}$ = logic high or open for normal operation
13,14,15,16	V_{S-}	Negative amplifier power supply input

TYPICAL CHARACTERISTICS

TYPICAL AC PERFORMANCE: $V_{S+} - V_{S-} = 5\text{ V}$

Test conditions unless otherwise noted: $V_{S+} = +2.5\text{ V}$, $V_{S-} = -2.5\text{ V}$, CM = open, $V_O = 2\text{ V}_{PP}$, $R_F = 349\ \Omega$, $R_L = 200\ \Omega$
Differential, G = 10 dB, Single-Ended Input, Input and Output Referenced to Midrail

Small-Signal Frequency Response		Figure 1
Large Signal Frequency Response		Figure 2
0.1 dB Flatness		Figure 3
Harmonic Distortion	HD ₂ , G = 6 dB, $V_{OD} = 2\text{ V}_{PP}$	vs Frequency Figure 4
	HD ₃ , G = 6 dB, $V_{OD} = 2\text{ V}_{PP}$	vs Frequency Figure 5
	HD ₂ , G = 10 dB, $V_{OD} = 2\text{ V}_{PP}$	vs Frequency Figure 6
	HD ₃ , G = 10 dB, $V_{OD} = 2\text{ V}_{PP}$	vs Frequency Figure 7
	HD ₂ , G = 14 dB, $V_{OD} = 2\text{ V}_{PP}$	vs Frequency Figure 8
	HD ₃ , G = 14 dB, $V_{OD} = 2\text{ V}_{PP}$	vs Frequency Figure 9
	HD ₂ , G = 10 dB	vs Output voltage Figure 10
	HD ₃ , G = 10 dB	vs Output voltage Figure 11
Intermodulation Distortion	IMD ₂ , G = 6 dB, $V_{OD} = 2\text{ V}_{PP}$	vs Frequency Figure 12
	IMD ₃ , G = 6 dB, $V_{OD} = 2\text{ V}_{PP}$	vs Frequency Figure 13
	IMD ₂ , G = 10 dB, $V_{OD} = 2\text{ V}_{PP}$	vs Frequency Figure 14
	IMD ₃ , G = 10 dB, $V_{OD} = 2\text{ V}_{PP}$	vs Frequency Figure 15
	IMD ₂ , G = 14 dB, $V_{OD} = 2\text{ V}_{PP}$	vs Frequency Figure 16
	IMD ₃ , G = 14 dB, $V_{OD} = 2\text{ V}_{PP}$	vs Frequency Figure 17
Output Intercept Point	OIP ₂	vs Frequency Figure 18
	OIP ₃	vs Frequency Figure 19
S-Parameters		vs Frequency Figure 20
Slew Rate		vs Output Voltage Figure 21
Transient Response		Figure 22
Settling Time		Figure 23
Rejection Ratio		vs Frequency Figure 24
Output Impedance		vs Frequency Figure 25
Overdrive Recovery		Figure 26
Output Voltage Swing		vs Load Resistance Figure 27
Turn-Off Time		Figure 28
Turn-On Time		Figure 29
Input Offset Voltage		vs Input Common-Mode Voltage Figure 30
Open Loop Gain		vs Frequency Figure 31
Input Referred Noise		vs Frequency Figure 32
Noise Figure		vs Frequency Figure 33
Quiescent Current		vs Supply Voltage Figure 34
Power Supply Current		vs Supply Voltage in Powerdown Mode Figure 35
Output Balance Error		vs Frequency Figure 36
CM Input Impedance		vs Frequency Figure 37
CM Small-Signal Frequency Response		Figure 38
CM Input Bias Current		vs CM Input Voltage Figure 39
Differential Output Offset Voltage		vs CM Input Voltage Figure 40
Output Common-Mode Offset		vs CM Input Voltage Figure 41

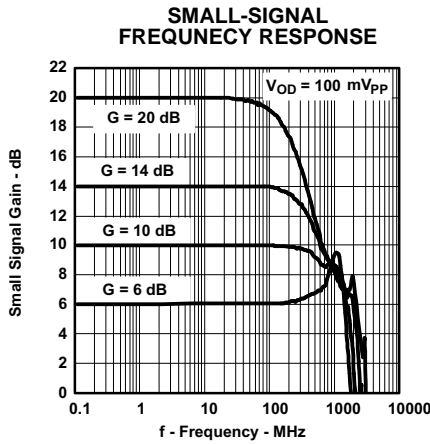

Figure 1.

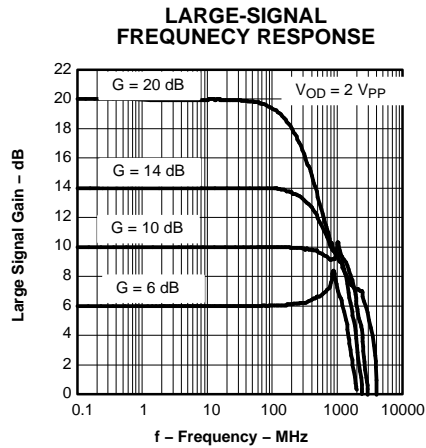

Figure 2.

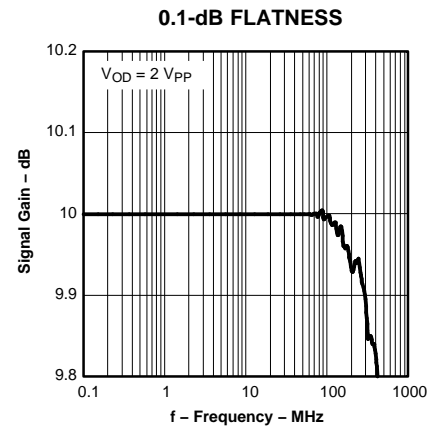

Figure 3.

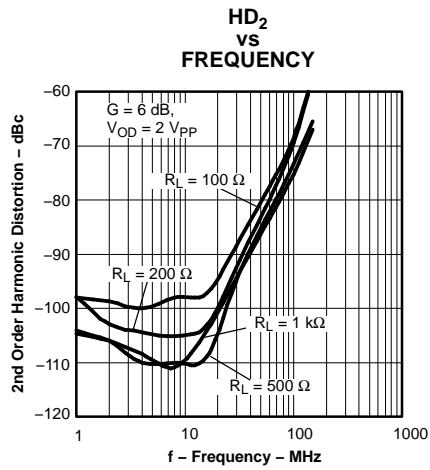

Figure 4.

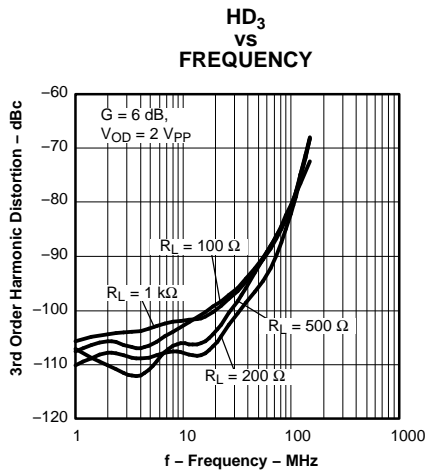

Figure 5.

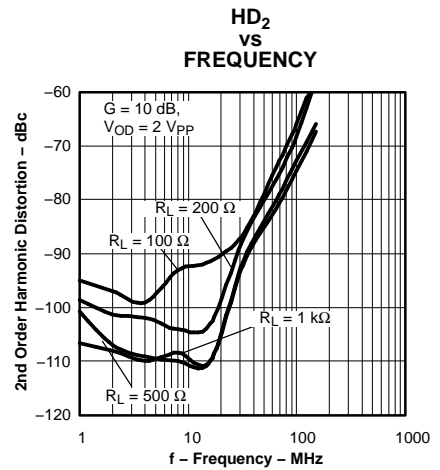

Figure 6.

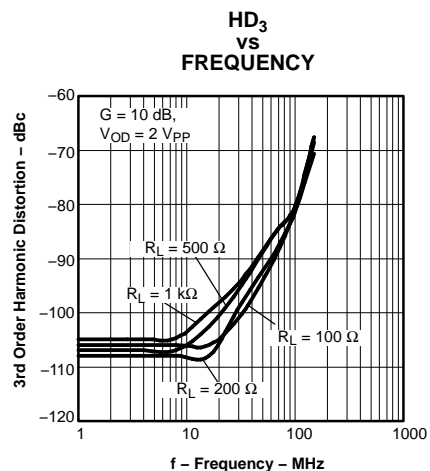

Figure 7.

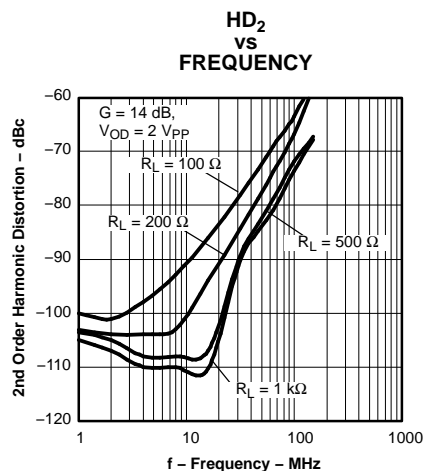

Figure 8.

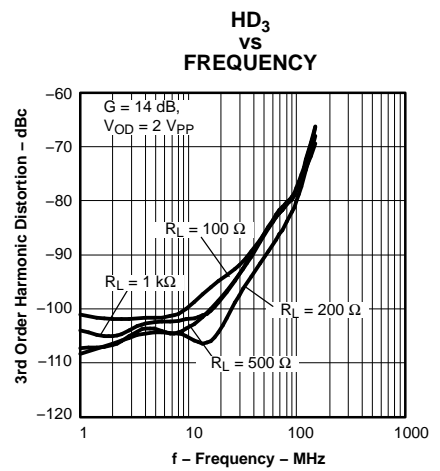

Figure 9.

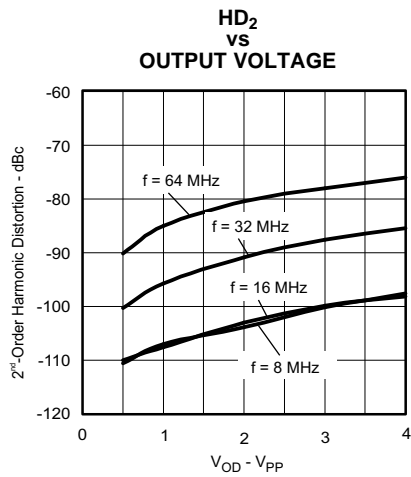

Figure 10.

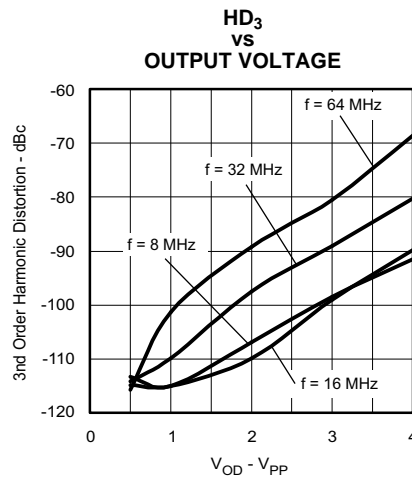

Figure 11.

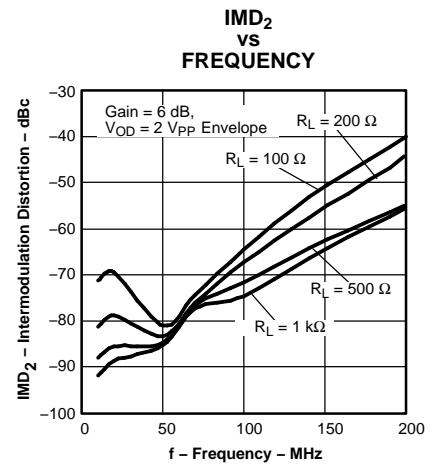

Figure 12.

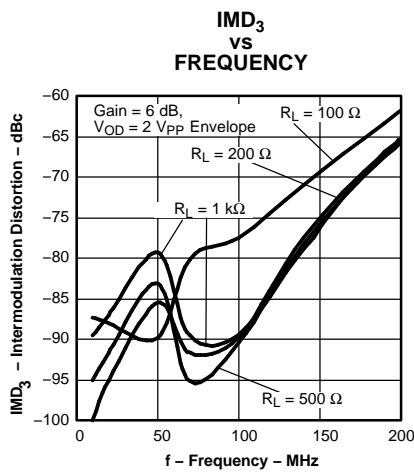

Figure 13.

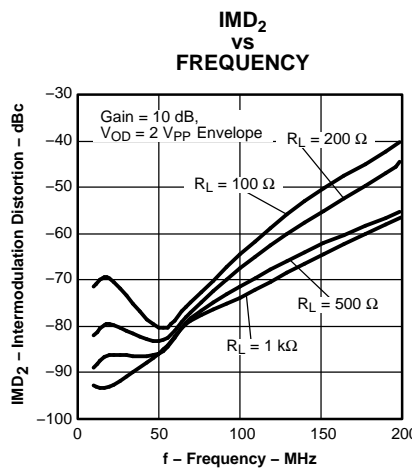

Figure 14.

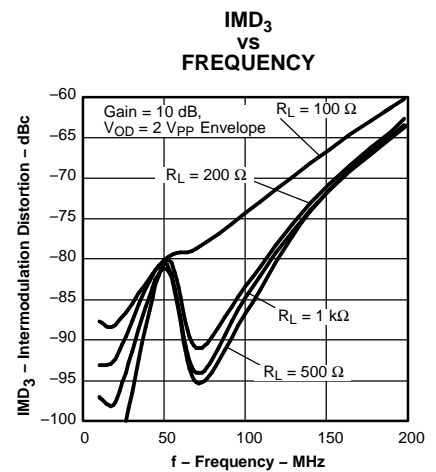

Figure 15.

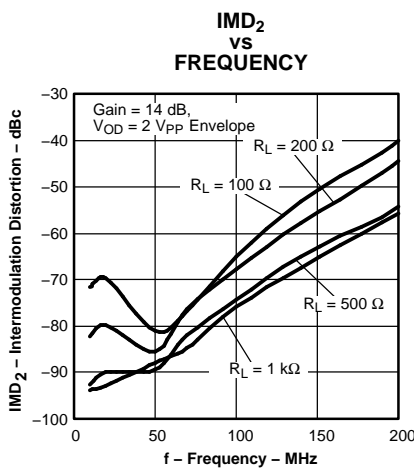

Figure 16.

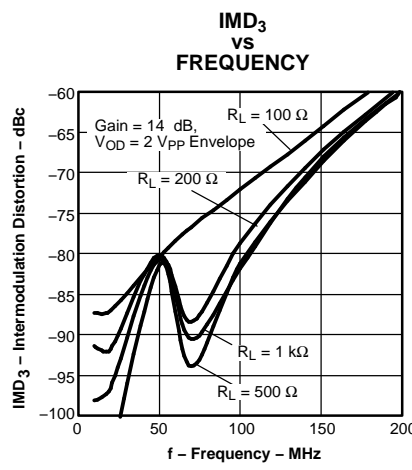

Figure 17.

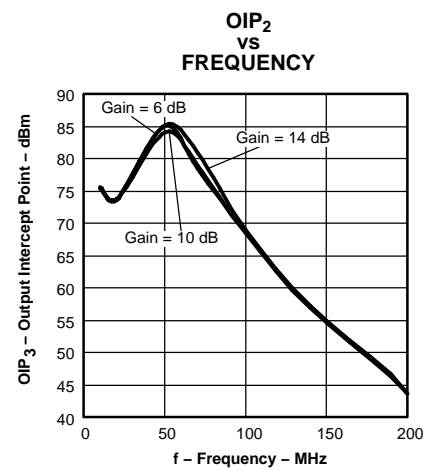

Figure 18.

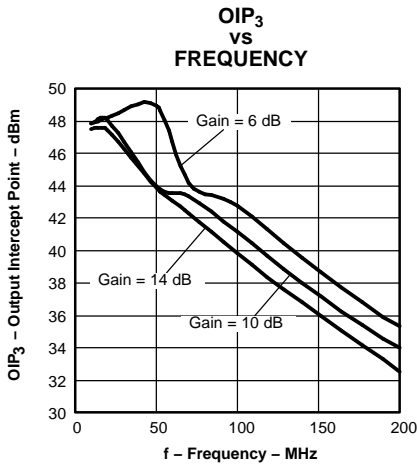

Figure 19.

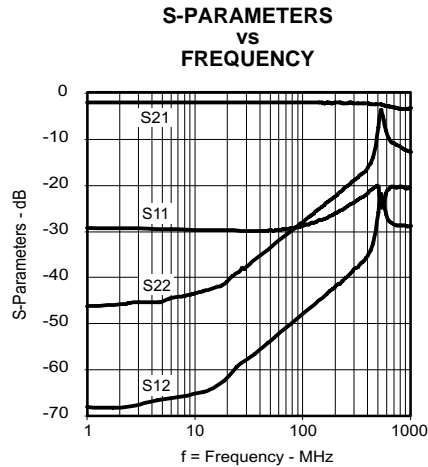

Figure 20.

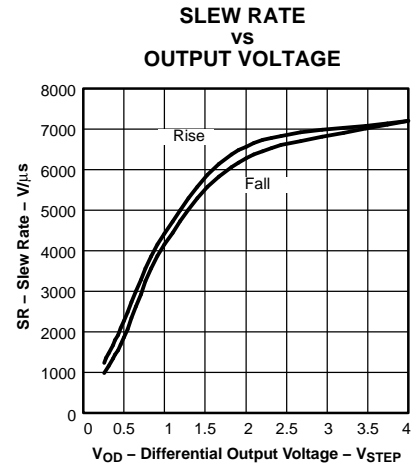

Figure 21.

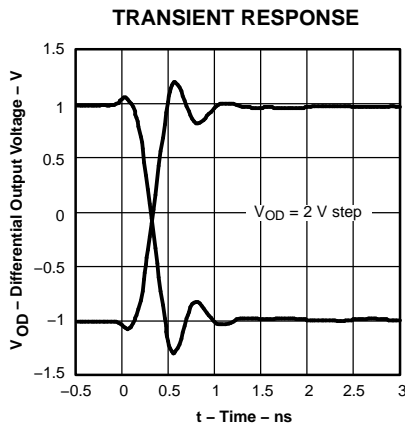

Figure 22.

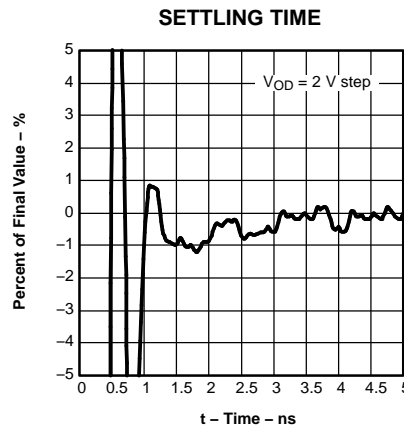

Figure 23.

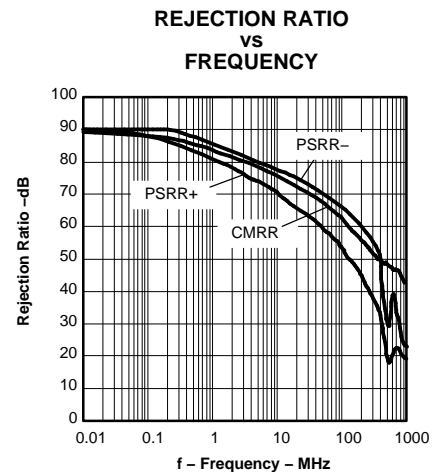

Figure 24.

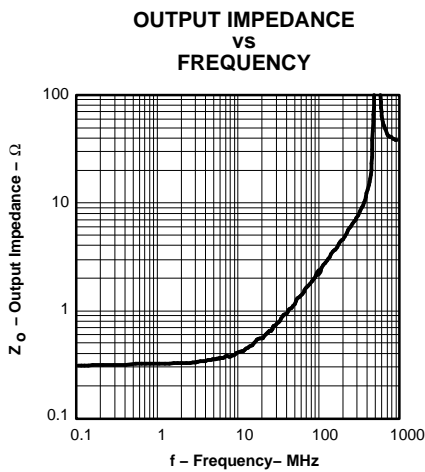

Figure 25.

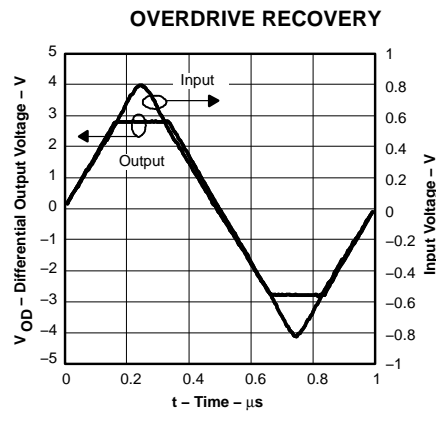

Figure 26.

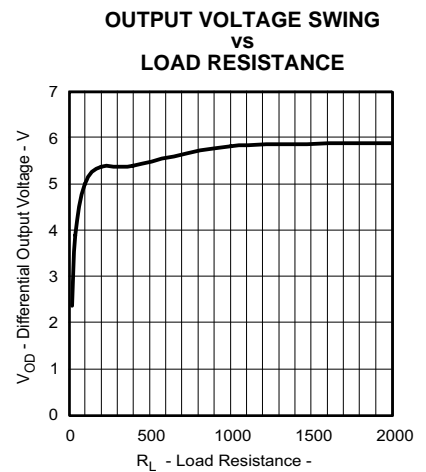

Figure 27.

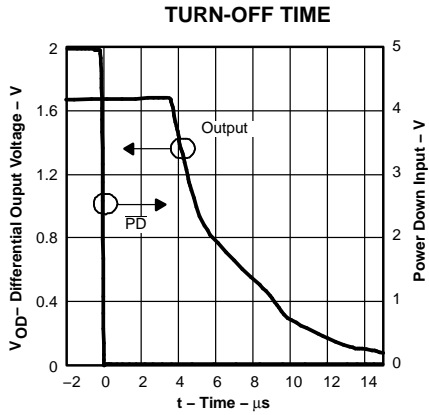

Figure 28.

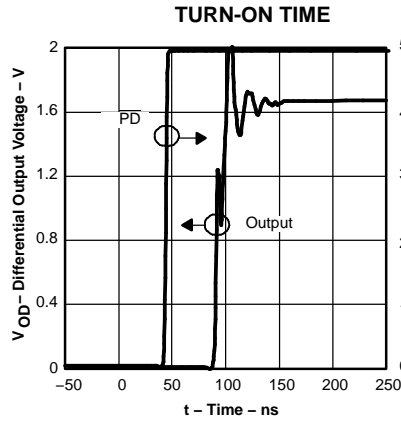

Figure 29.

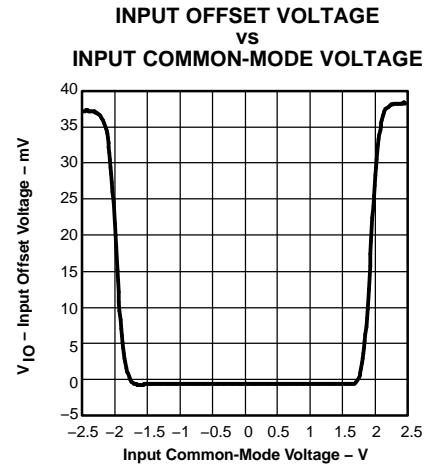

Figure 30.

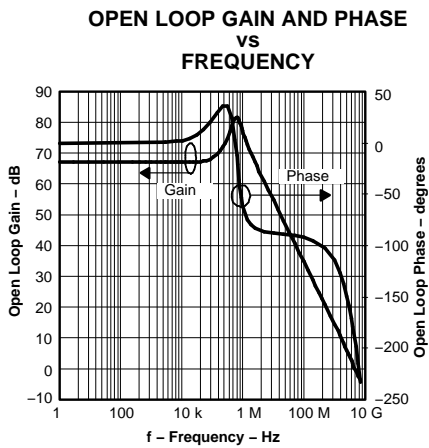

Figure 31.

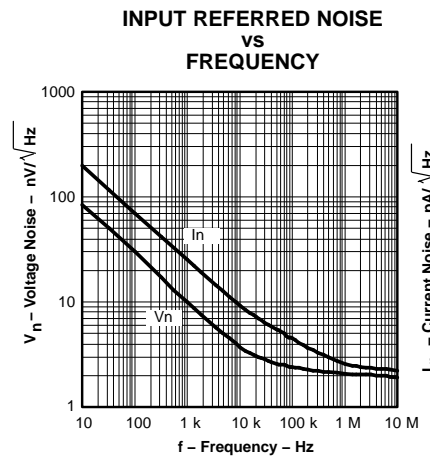

Figure 32.

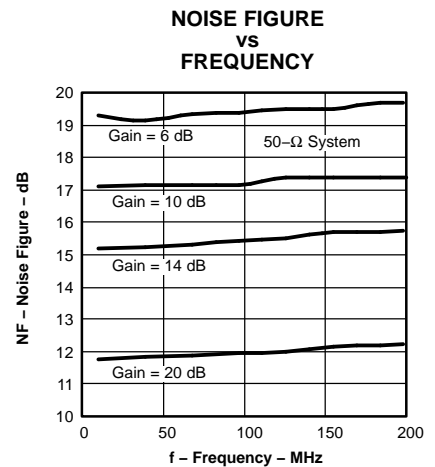

Figure 33.

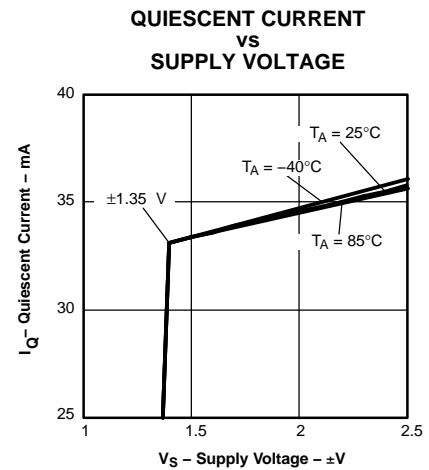

Figure 34.

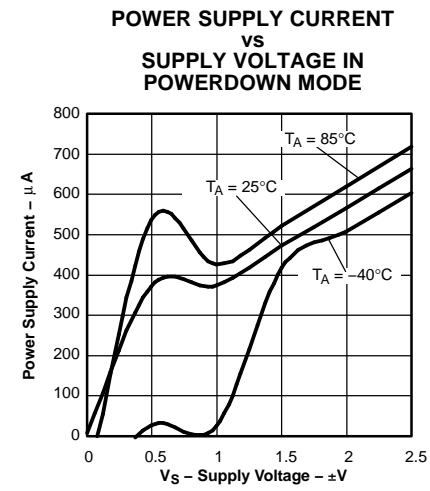

Figure 35.

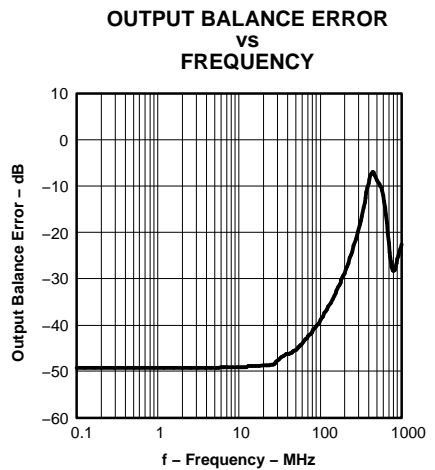

Figure 36.

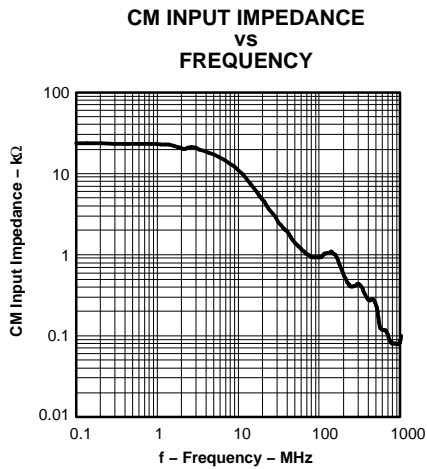

Figure 37.

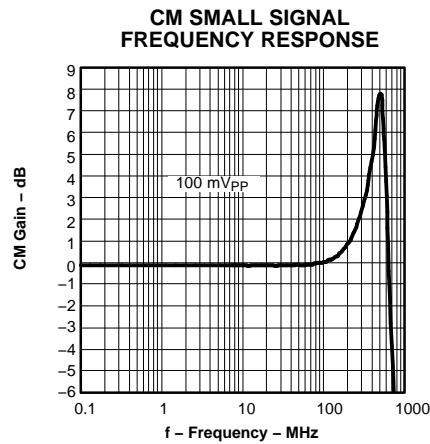

Figure 38.

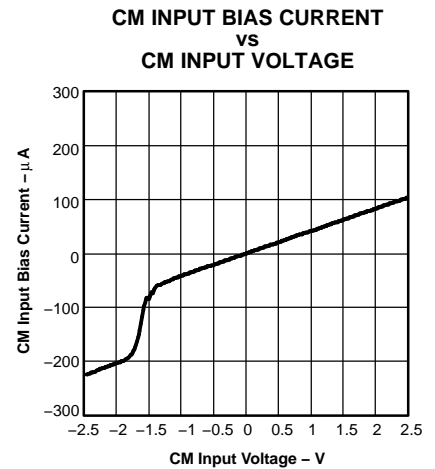

Figure 39.

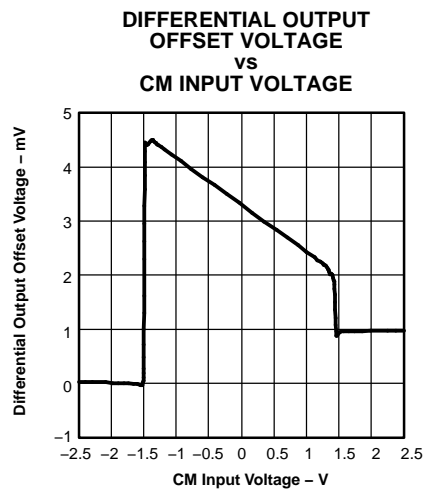

Figure 40.

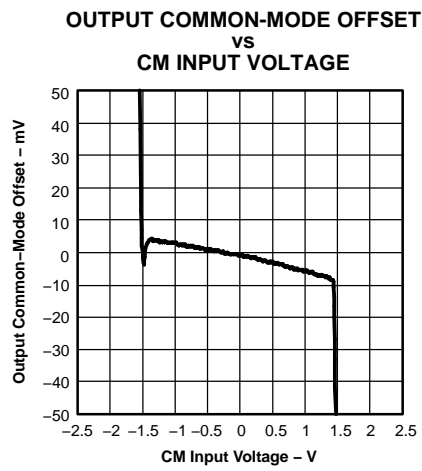

Figure 41.

TYPICAL AC PERFORMANCE: $V_{S+} - V_{S-} = 3\text{ V}$

Test conditions unless otherwise noted: $V_{S+} = +1.5\text{ V}$, $V_{S-} = -1.5\text{ V}$, CM = open, $V_{OD} = 1\text{ V}_{PP}$, $R_F = 349\ \Omega$, $R_L = 200\ \Omega$
Differential, G = 10 dB, Single-Ended Input, Input and Output Referenced to Midrail

Small-Signal Frequency Response		Figure 42
Large Signal Frequency Response		Figure 43
0.1 dB Flatness		Figure 44
Harmonic Distortion	HD ₂ , G = 6 dB, $V_{OD} = 1\text{ V}_{PP}$	vs Frequency Figure 45
	HD ₃ , G = 6 dB, $V_{OD} = 1\text{ V}_{PP}$	vs Frequency Figure 46
	HD ₂ , G = 10 dB, $V_{OD} = 1\text{ V}_{PP}$	vs Frequency Figure 47
	HD ₃ , G = 10 dB, $V_{OD} = 1\text{ V}_{PP}$	vs Frequency Figure 48
	HD ₂ , G = 14 dB, $V_{OD} = 1\text{ V}_{PP}$	vs Frequency Figure 49
	HD ₃ , G = 14 dB, $V_{OD} = 1\text{ V}_{PP}$	vs Frequency Figure 50
Intermodulation Distortion	IMD ₂ , G = 6 dB, $V_{OD} = 1\text{ V}_{PP}$	vs Frequency Figure 51
	IMD ₃ , G = 6 dB, $V_{OD} = 1\text{ V}_{PP}$	vs Frequency Figure 52
	IMD ₂ , G = 10 dB, $V_{OD} = 1\text{ V}_{PP}$	vs Frequency Figure 53
	IMD ₃ , G = 10 dB, $V_{OD} = 1\text{ V}_{PP}$	vs Frequency Figure 54
	IMD ₂ , G = 14 dB, $V_{OD} = 1\text{ V}_{PP}$	vs Frequency Figure 55
Output Intercept Point	OIP ₂	vs Frequency Figure 57
	OIP ₃	vs Frequency Figure 58
S-Parameters		vs Frequency Figure 59
Slew Rate		vs Output Voltage Figure 60
Transient Response		Figure 61
Settling Time		Figure 62
Output Voltage Swing		vs Load Resistance Figure 63
Rejection Ratio		vs Frequency Figure 64
Overdrive Recovery		Figure 65
Output Impedance		vs Frequency Figure 66
Turn-Off Time		Figure 67
Turn-On Time		Figure 68
Output Balance Error		vs Frequency Figure 69
Noise Figure		vs Frequency Figure 70
CM Small-Signal Frequency Response		Figure 71
CM Input Impedance		vs Frequency Figure 72
Differential Output Offset Voltage		vs CM Input Voltage Figure 73
Output Common-Mode Offset		vs CM Input Voltage Figure 74

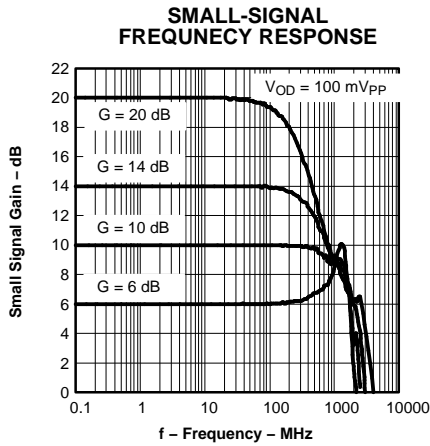

Figure 42.

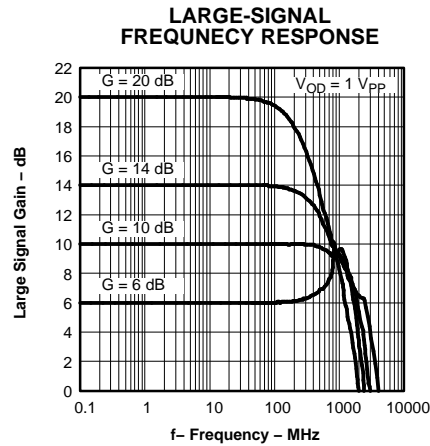

Figure 43.

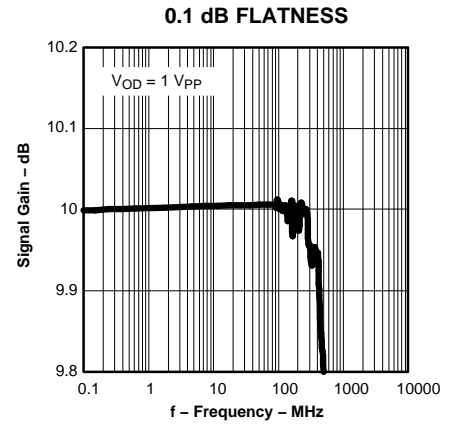

Figure 44.

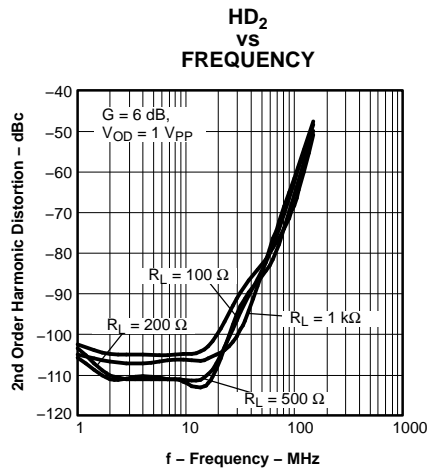

Figure 45.

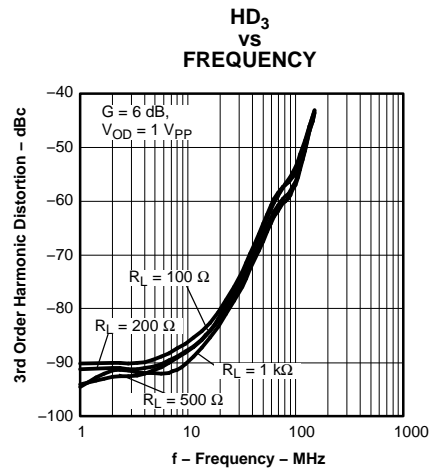

Figure 46.

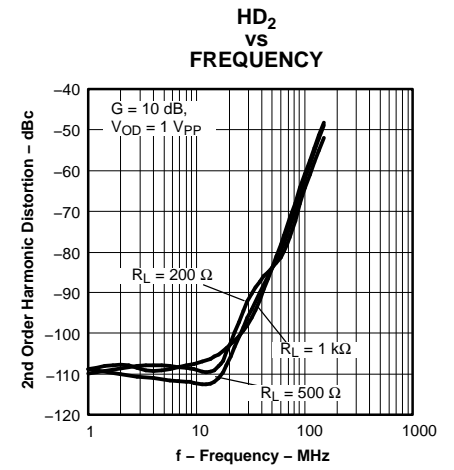

Figure 47.

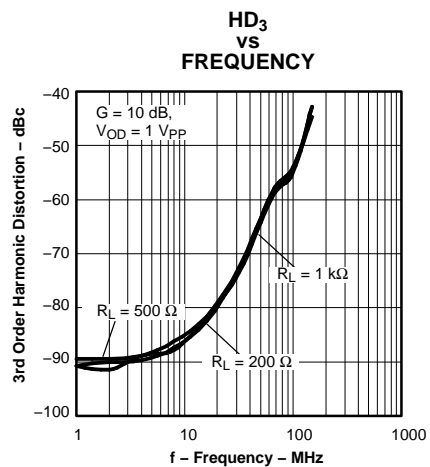

Figure 48.

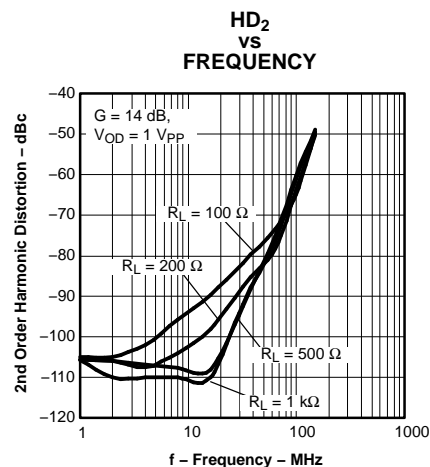

Figure 49.

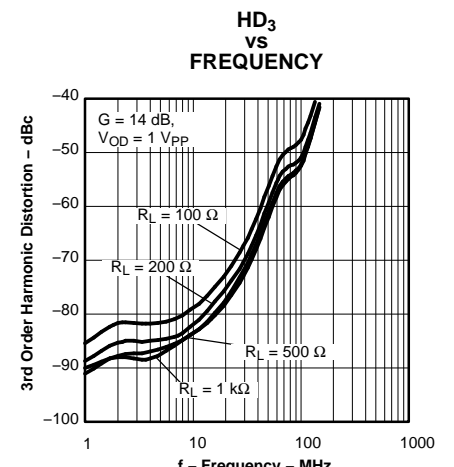

Figure 50.

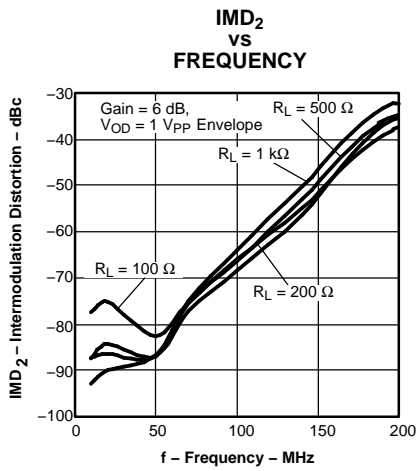

Figure 51.

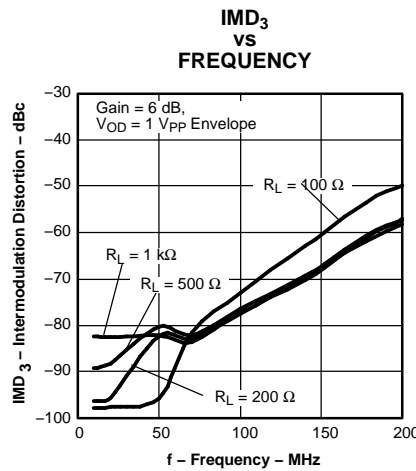

Figure 52.

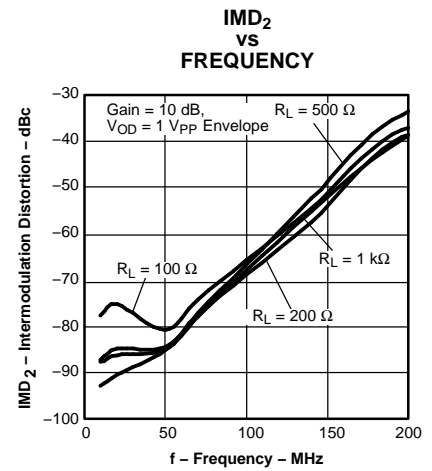

Figure 53.

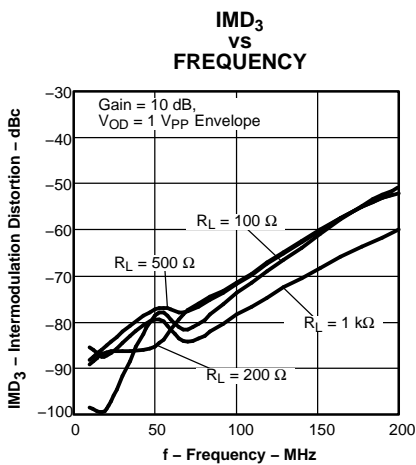

Figure 54.

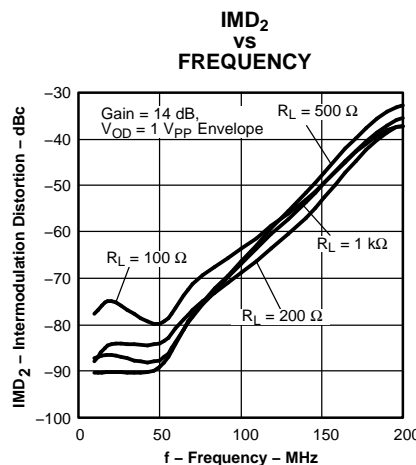

Figure 55.

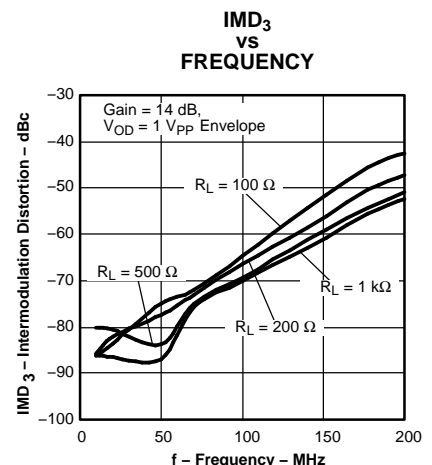

Figure 56.

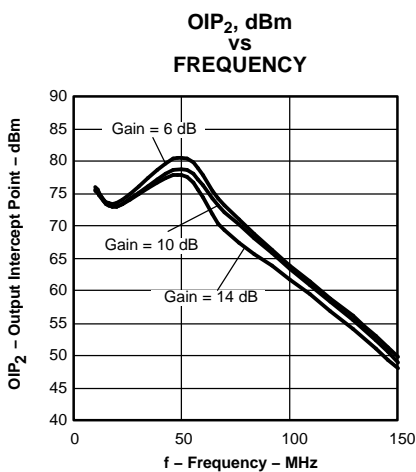

Figure 57.

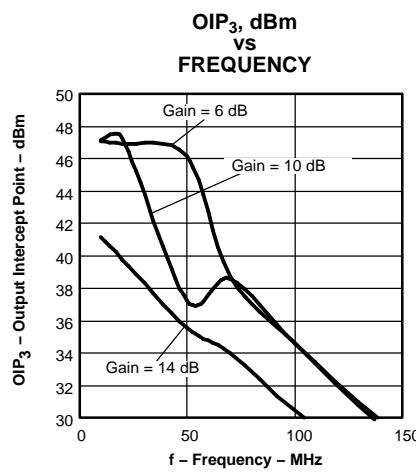

Figure 58.

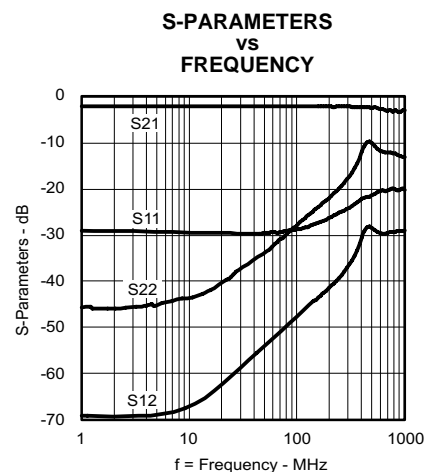

Figure 59.

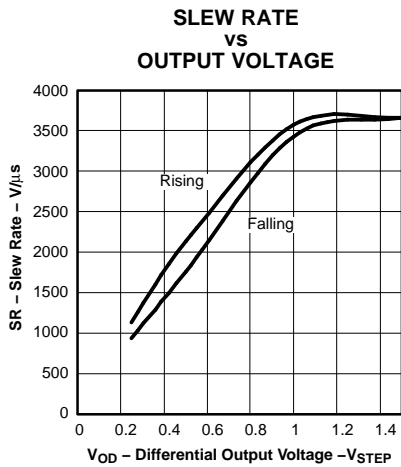

Figure 60.

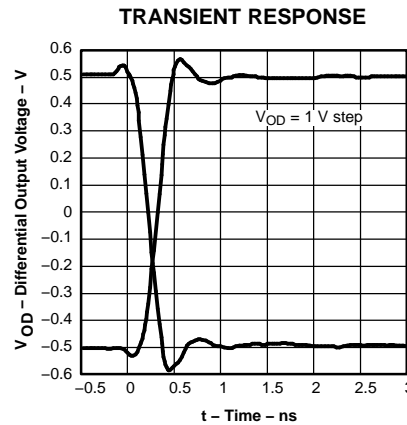

Figure 61.

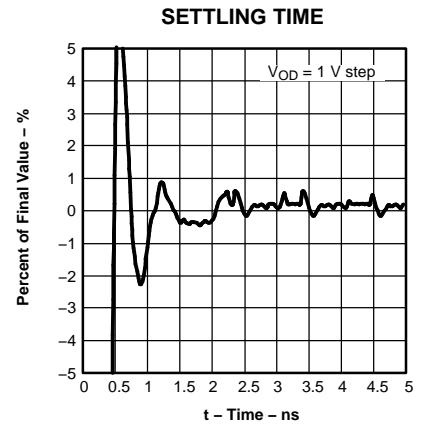

Figure 62.

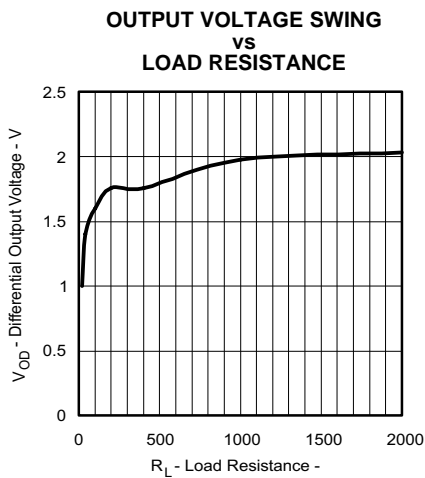

Figure 63.

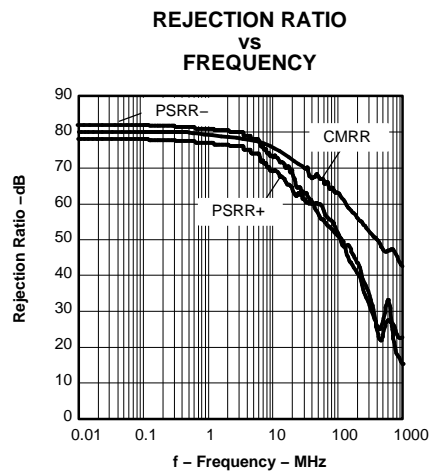

Figure 64.

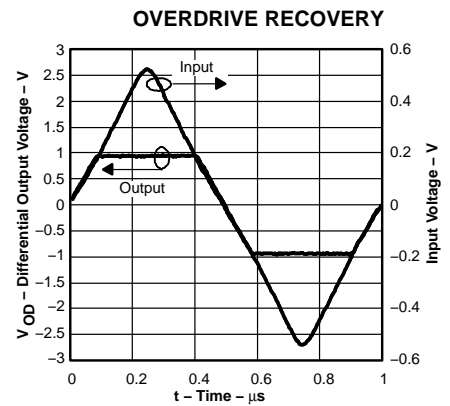

Figure 65.

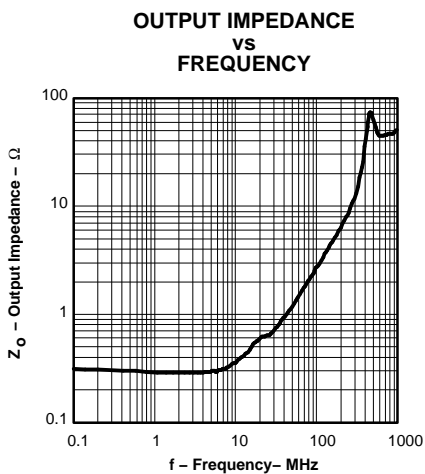

Figure 66.

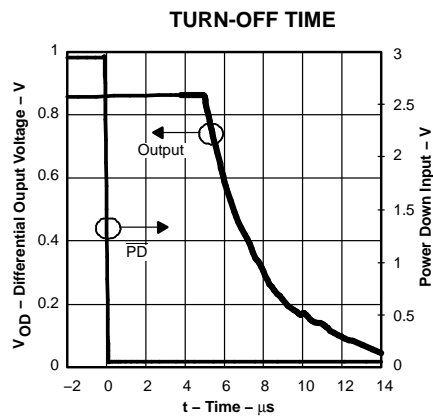

Figure 67.

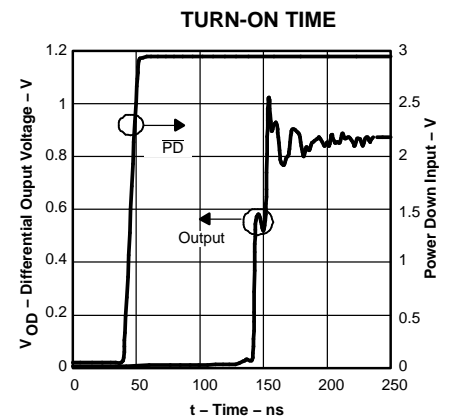

Figure 68.

**OUTPUT BALANCE ERROR
vs
FREQUENCY**

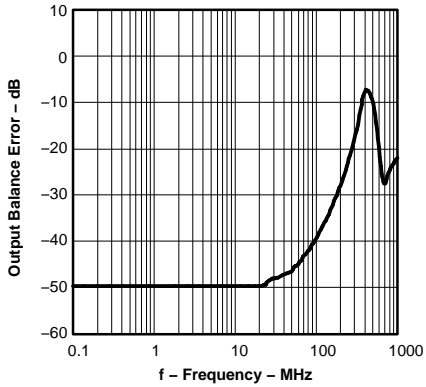

Figure 69.

**NOISE FIGURE
vs
FREQUENCY**

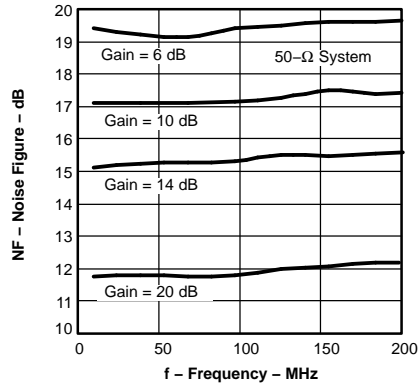

Figure 70.

**CM SMALL SIGNAL
FREQUENCY RESPONSE**

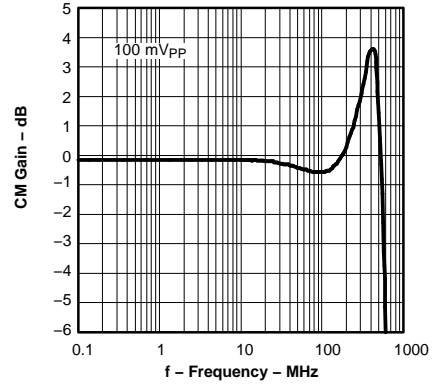

Figure 71.

**CM INPUT IMPEDANCE
vs
FREQUENCY**

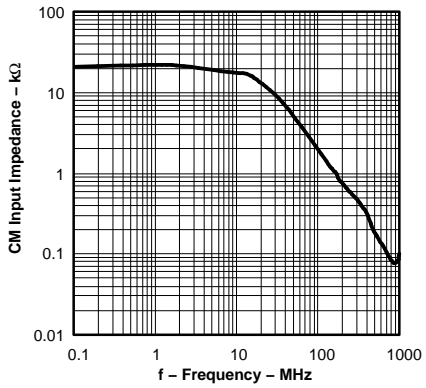

Figure 72.

**DIFFERENTIAL OUTPUT OFFSET
VOLTAGE
vs
CM INPUT VOLTAGE**

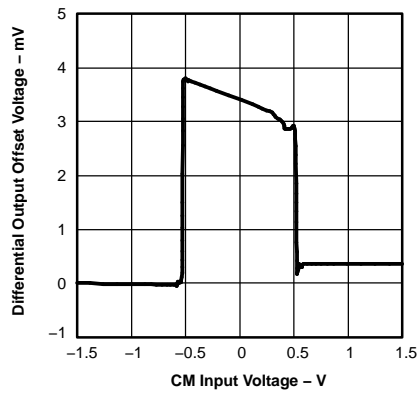

Figure 73.

**OUTPUT COMMON-MODE OFFSET
vs
CM INPUT VOLTAGE**

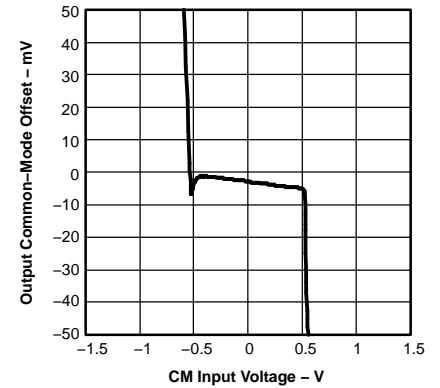

Figure 74.

TEST CIRCUITS

The THS4509 is tested with the following test circuits built on the EVM. For simplicity, power supply decoupling is not shown – see layout in the applications section for recommendations. Depending on the test conditions, component values are changed per the following tables, or as otherwise noted. The signal generators used are ac coupled 50-Ω sources and a 0.22-μF capacitor and a 49.9-Ω resistor to ground are inserted across R_{IT} on the alternate input to balance the circuit. A split power supply is used to ease the interface to common test equipment, but the amplifier can be operated single-supply as described in the applications section with no impact on performance.

Table 1. Gain Component Values

GAIN	R_F	R_G	R_{IT}
6 dB	348 Ω	165 Ω	61.9 Ω
10 dB	348 Ω	100 Ω	69.8 Ω
14 dB	348 Ω	56.2 Ω	88.7 Ω
20 dB	348 Ω	16.5 Ω	287 Ω

Note the gain setting includes 50-Ω source impedance. Components are chosen to achieve gain and 50-Ω input termination.

Table 2. Load Component Values

R_L	R_O	R_{OT}	Atten.
100 Ω	25 Ω	open	6 dB
200 Ω	86.6 Ω	69.8 Ω	16.8 dB
499 Ω	237 Ω	56.2 Ω	25.5 dB
1k Ω	487 Ω	52.3 Ω	31.8 dB

Note the total load includes 50-Ω termination by the test equipment. Components are chosen to achieve load and 50-Ω line termination through a 1:1 transformer.

Due to the voltage divider on the output formed by the load component values, the amplifier's output is attenuated. The column *Atten* in Table 2 shows the attenuation expected from the resistor divider. When using a transformer at the output as shown in Figure 76, the signal will see slightly more loss, and these numbers will be approximate.

Frequency Response

The circuit shown in Figure 75 is used to measure the frequency response of the circuit.

A network analyzer is used as the signal source and as the measurement device. The output impedance of the network analyzer is 50 Ω. R_{IT} and R_G are chosen to impedance match to 50 Ω, and to maintain the proper gain. To balance the amplifier, a 0.22-μF capacitor and 49.9-Ω resistor to ground are inserted across R_{IT} on the alternate input.

The output is probed using a high-impedance differential probe across the 100-Ω resistor. The gain is referred to the amplifier output by adding back the 6-dB loss due to the voltage divider on the output.

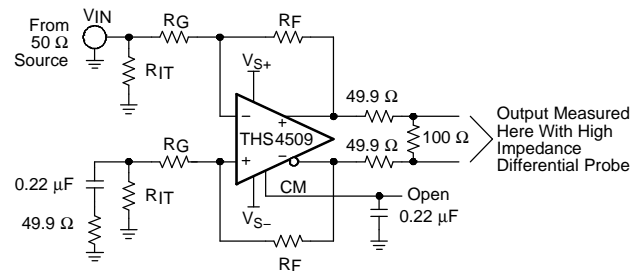

Figure 75. Frequency Response Test Circuit

Distortion and 1dB Compression

The circuit shown in Figure 76 is used to measure harmonic distortion, intermodulation distortion, and 1-dB compression point of the amplifier.

A signal generator is used as the signal source and the output is measured with a spectrum analyzer. The output impedance of the signal generator is 50 Ω. R_{IT} and R_G are chosen to impedance-match to 50 Ω, and to maintain the proper gain. To balance the amplifier, a 0.22-μF capacitor and 49.9-Ω resistor to ground are inserted across R_{IT} on the alternate input.

A low-pass filter is inserted in series with the input to reduce harmonics generated at the signal source. The level of the fundamental is measured, then a high-pass filter is inserted at the output to reduce the fundamental so that it does not generate distortion in the input of the spectrum analyzer.

The transformer used in the output to convert the signal from differential to single ended is an ADT1-1WT. It limits the frequency response of the circuit so that measurements cannot be made below approximately 1MHz.

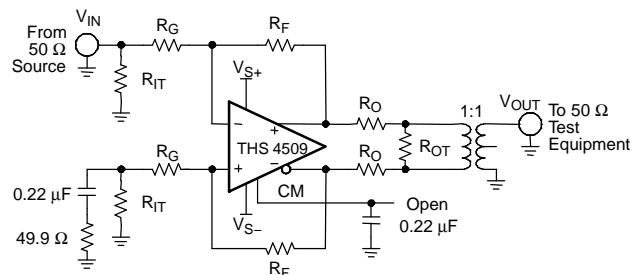

Figure 76. Distortion Test Circuit

The 1-dB compression point is measured with a spectrum analyzer with 50-Ω double termination or

100-Ω termination as shown in Table 2. The input power is increased until the output is 1 dB lower than expected. The number reported in the table data is the power delivered to the spectrum analyzer input. Add 3 dB to refer to the amplifier output.

S-Parameter, Slew Rate, Transient Response, Settling Time, Output Impedance, Overdrive, Output Voltage, and Turn-On/Off Time

The circuit shown in Figure 77 is used to measure s-parameters, slew rate, transient response, settling time, output impedance, overdrive recovery, output voltage swing, and turn-on/turn-off times of the amplifier. For output impedance, the signal is injected at V_{OUT} with V_{IN} left open and the drop across the 49.9 Ω resistor is used to calculate the impedance seen looking into the amplifier’s output.

Because S_{21} is measured single-ended at the load with 50-Ω double termination, add 12 dB to refer to the amplifier’s output as a differential signal.

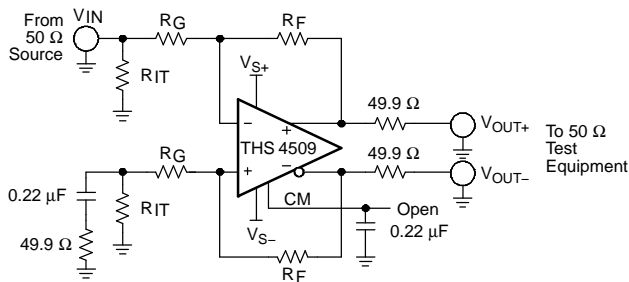

Figure 77. S-Parameter, SR, Transient Response, Settling Time, Z_O , Overdrive Recovery, V_{OUT} Swing, and Turn-on/off Test Circuit

CM Input

The circuit shown in Figure 78 is used to measure the frequency response and input impedance of the CM input. Frequency response is measured single-ended

at V_{OUT+} or V_{OUT-} with the input injected at V_{IN} , $R_{CM} = 0 \Omega$ and $R_{CMT} = 49.9 \Omega$. The input impedance is measured with $R_{CM} = 49.9 \Omega$ with $R_{CMT} =$ open, and calculated by measuring the voltage drop across R_{CM} to determine the input current.

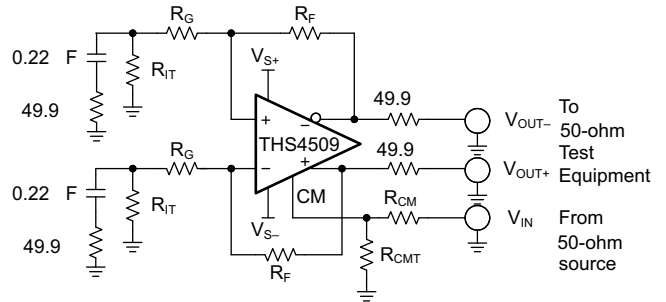

Figure 78. CM Input Test Circuit

CMRR and PSRR

The circuit shown in Figure 79 is used to measure the CMRR and PSRR of V_{S+} and V_{S-} . The input is switched appropriately to match the test being performed.

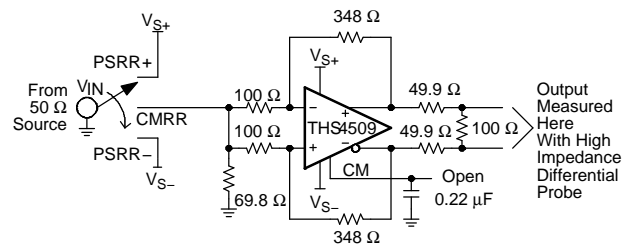

Figure 79. CMRR and PSRR Test Circuit

APPLICATION INFORMATION

APPLICATIONS

The following circuits show application information for the THS4509. For simplicity, power supply decoupling capacitors are not shown in these diagrams. Please see the Subsection 1 section for recommendations. For more detail on the use and operation of fully differential op amps refer to application report *Fully-Differential Amplifiers* (SLOA054).

Differential Input to Differential Output Amplifier

The THS4509 is a fully differential op amp, and can be used to amplify differential input signals to differential output signals. A basic block diagram of the circuit is shown in Figure 80 (CM input not shown). The gain of the circuit is set by R_F divided by R_G .

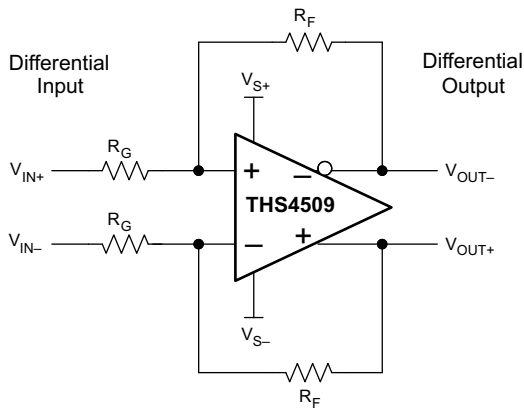

Figure 80. Differential Input to Differential Output Amplifier

Depending on the source and load, input and output termination can be accomplished by adding R_{IT} and R_O .

Single-Ended Input to Differential Output Amplifier

The THS4509 can be used to amplify and convert single-ended input signals to differential output signals. A basic block diagram of the circuit is shown in Figure 81 (CM input not shown). The gain of the circuit is again set by R_F divided by R_G .

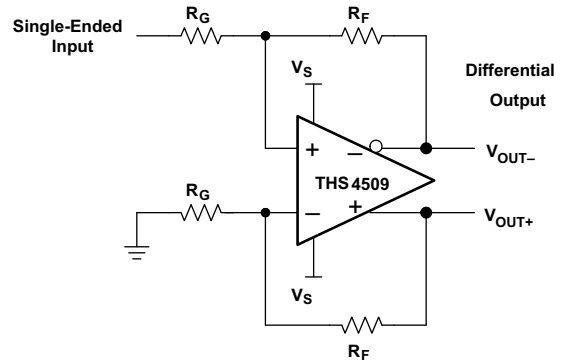

Figure 81. Single-Ended Input to Differential Output Amplifier

Input Common-Mode Voltage Range

The input common-mode voltage of a fully differential op amp is the voltage at the '+' and '-' input pins of the op amp.

It is important to not violate the input common-mode voltage range (V_{ICR}) of the op amp. Assuming the op amp is in linear operation the voltage across the input pins is only a few millivolts at most. So finding the voltage at one input pin will determine the input common-mode voltage of the op amp.

Treating the negative input as a summing node, the voltage is given by Equation 1:

$$V_{IC} = V_{OUT} \frac{R_G}{R_G + R_F} + V_{IN} \frac{R_F}{R_G + R_F} \quad (1)$$

To determine the V_{ICR} of the op amp, the voltage at the negative input is evaluated at the extremes of V_{OUT+} .

As the gain of the op amp increases, the input common-mode voltage becomes closer and closer to the input common-mode voltage of the source.

Setting the Output Common-Mode Voltage

The output common-mode voltage is set by the voltage at the CM pin(s). The internal common-mode control circuit maintains the output common-mode voltage within 3-mV offset (typ) from the set voltage, when set within 0.5 V of mid-supply, with less than 4mV differential offset voltage. If left unconnected, the common-mode set point is set to mid-supply by internal circuitry, which may be over-driven from an external source. Figure 82 is representative of the CM input. The internal CM circuit has about 700 MHz of -3 -dB bandwidth, which is required for best per-

formance, but it is intended to be a DC bias input pin. Bypass capacitors are recommended on this pin to reduce noise at the output. The external current required to overdrive the internal resistor divider is given by Equation 2:

$$I_{EXT} = \frac{2V_{CM}}{50\text{ k}} \frac{V_S}{V_S} \tag{2}$$

where V_{CM} is the voltage applied to the CM pin.

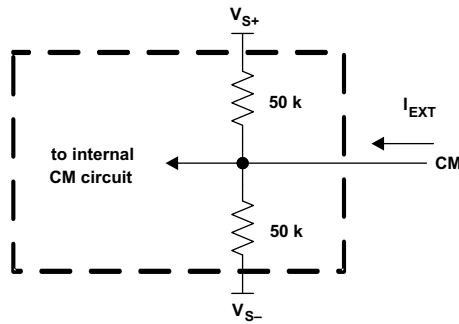

Figure 82. CM Input Circuit

Single-Supply Operation (3V to 5V)

To facilitate testing with common lab equipment, the THS4509 EVM allows split-supply operation, and the characterization data presented in this data sheet was taken with split-supply power inputs. The device can easily be used with a single-supply power input without degrading the performance. Figure 83, Figure 84, and Figure 85 show DC and AC-coupled single-supply circuits with single-ended inputs. These configurations all allow the input and output common-mode voltage to be set to mid-supply allowing for optimum performance. The information presented here can also be applied to differential input sources.

In Figure 83, the source is referenced to the same voltage as the CM pin (V_{CM}). V_{CM} is set by the internal circuit to mid-supply. R_T along with the input impedance of the amplifier circuit provides input termination, which is also referenced to V_{CM} .

Note R_S and R_T are added to the alternate input from the signal input to balance the amplifier. Alternately, one resistor can be used equal to the combined value $R_G + R_S || R_T$ on this input. This is also true of the circuits shown in Figure 84 and Figure 85.

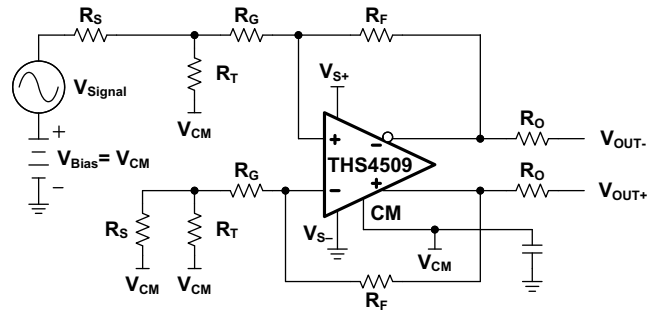

Figure 83. THS4509 DC Coupled Single-Supply with Input Biased to V_{CM}

In Figure 84 the source is referenced to ground and so is the input termination resistor. R_{PU} is added to the circuit to avoid violating the V_{ICR} of the op amp. The proper value of resistor to add can be calculated from Equation 3:

$$R_{PU} = \frac{V_{IC} V_S}{V_{CM} \frac{1}{R_F} V_{IC} \frac{1}{R_{IN}} \frac{1}{R_F}} \tag{3}$$

V_{IC} is the desire input common-mode voltage, $V_{CM} = V_{CM}$, and $R_{IN} = R_G + R_S || R_T$. To set to mid-supply, make the value of $R_{PU} = R_G + R_S || R_T$.

Table 3 is a modification of Table 1 to add the proper values with R_{PU} assuming a 50 Ω source impedance and setting the input and output common-mode voltage to mid-supply.

There are two drawbacks to this configuration. One is it requires additional current from the power supply. Using the values shown for a gain of 10 dB requires 37 mA more current with 5 V supply, and 22 mA more current with 3 V supply.

The other drawback is this configuration also increases the noise gain of the circuit. In the 10 dB gain case, noise gain increases by a factor of 1.5.

Table 3. RPU Values for Various Gains

Gain	R_F	R_G	R_{IT}	R_{PU}
6 dB	348 Ω	169 Ω	64.9 Ω	200 Ω
10 dB	348 Ω	102 Ω	78.7 Ω	133 Ω
14 dB	348 Ω	61.9 Ω	115 Ω	97.6 Ω
20 dB	348 Ω	40.2 Ω	221 Ω	80.6 Ω

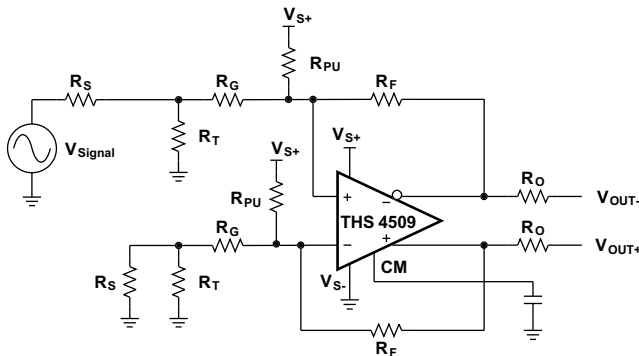

Figure 84. THS4509 DC Coupled Single-Supply with R_{PU} Used to Set V_{IC}

Figure 85 shows AC coupling to the source. Using capacitors in series with the termination resistors allows the amplifier to self-bias both input and output to mid-supply.

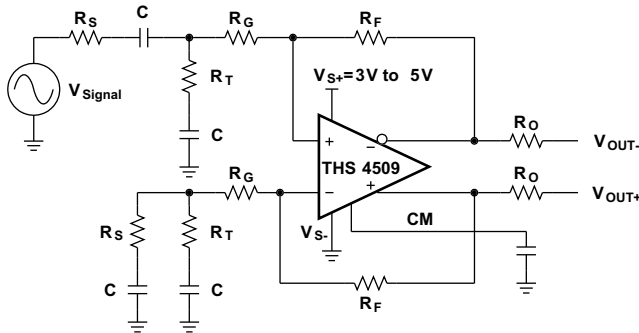

Figure 85. THS4509 AC Coupled Single-Supply

THS4509 + ADS5500 Combined Performance

The THS4509 is designed to be a high performance drive amplifier for high performance data converters like the ADS5500 14-bit 125-MSPS ADC. Figure 86 shows a circuit combining the two devices, and Figure 87 shows the combined SNR and SFDR performance versus frequency with -1 dBFS input signal level sampling at 125 MSPS. The THS4509 amplifier circuit provides 10 dB of gain, converts the single-ended input to differential, and sets the proper input common-mode voltage to the ADS5500. The 100- Ω resistors and 2.7-pF capacitor between the THS4509 outputs and ADS5500 inputs along with the input capacitance of the ADS5500 limit the bandwidth of the signal to 115 MHz (-3 dB). For testing, a signal generator is used for the signal source. The generator is an AC-coupled 50- Ω source. A band-pass filter

is inserted in series with the input to reduce harmonics and noise from the signal source. Input termination is accomplished via the 69.8- Ω resistor and 0.22- μ F capacitor to ground in conjunction with the input impedance of the amplifier circuit. A 0.22- μ F capacitor and 49.9- Ω resistor is inserted to ground across the 69.8- Ω resistor and 0.22- μ F capacitor on the alternate input to balance the circuit. Gain is a function of the source impedance, termination, and 348- Ω feedback resistor. Refer to Table 3 for component values to set proper 50- Ω termination for other common gains. A split power supply of +4V and -1V is used to set the input and output common-mode voltages to approximately mid-supply while setting the input common-mode of the ADS5500 to the recommended +1.55V. This maintains maximum headroom on the internal transistors of the THS4509 to insure optimum performance.

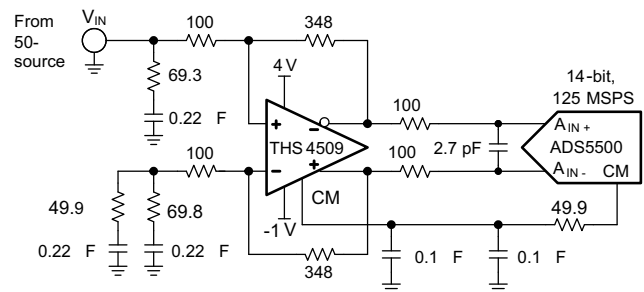

Figure 86. THS4509 + ADS5500 Circuit

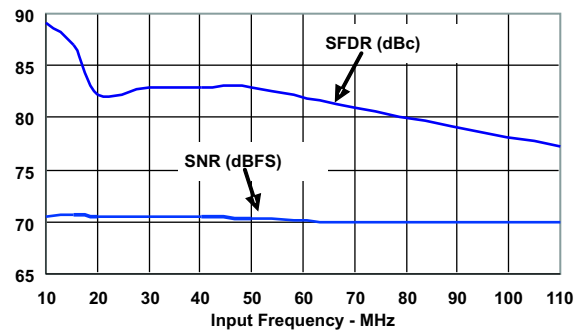

Figure 87. THS4509 + ADS5500 SFDR and SNR Performance versus Frequency

Figure 88 shows the 2-tone FFT of the THS4509 + ADS5500 circuit with 65 MHz and 70 MHz input frequencies. The SFDR is 90 dBc.

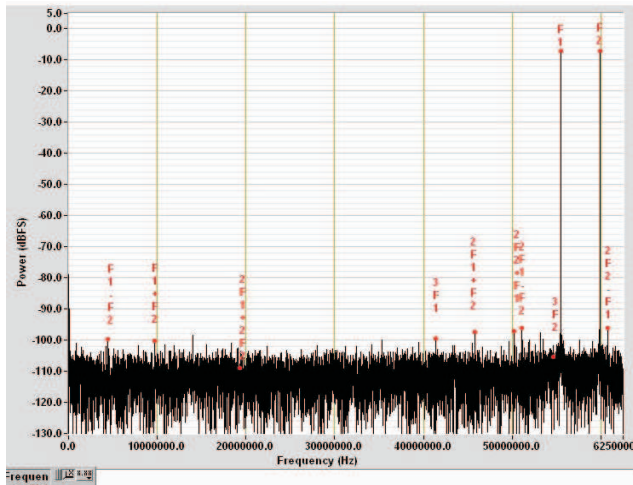

Figure 88. THS4509 + ADS5500 2-Tone FFT with 65 MHz and 70 MHz Input

THS4509 + ADS5424 Combined Performance

Figure 89 shows the THS4509 driving the ADS5424 ADC, and Figure 90 shows their combined SNR and SFDR performance versus frequency with -1 dBFS input signal level and sampling at 80 MSPS.

As before, the THS4509 amplifier provides 10 dB of gain, converts the single-ended input to differential, and sets the proper input common-mode voltage to the ADS5424. Input termination and circuit testing is the same as described above for the THS4509 + ADS5500 circuit.

The 225- Ω resistors and 2.7-pF capacitor between the THS4509 outputs and ADS5424 inputs (along with the input capacitance of the ADC) limit the bandwidth of the signal to about 100MHz (-3dB).

Since the ADS5424s recommended input common-mode voltage is 2.4 V, the THS4509 is operated from a single power supply input with $V_{S+} = 5$ V and $V_{S-} = 0$ V (ground).

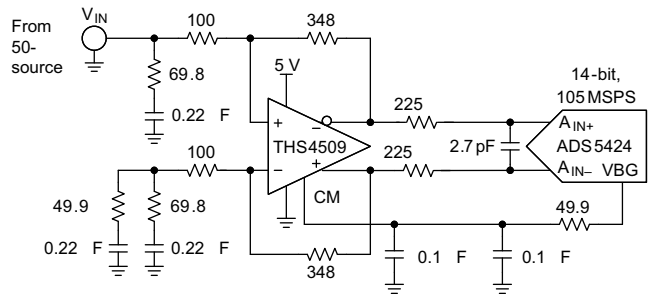

Figure 89. THS4509 + ADS5424 Circuit

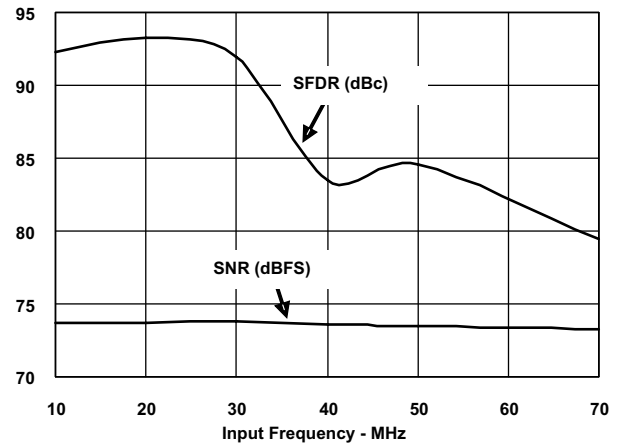

Figure 90. THS4509 + ADS5424 SFDR and SNR Performance vs Frequency

Layout Recommendations

It is recommended to follow the layout of the external components near the amplifier, ground plane construction, and power routing of the EVM as closely as possible. General guidelines are:

1. Signal routing should be direct and as short as possible into and out of the opamp circuit.
2. The feedback path should be short and direct avoiding vias.
3. Ground or power planes should be removed from directly under the amplifier's input and output pins.
4. An output resistor is recommended on each output, as near to the output pin as possible.
5. Two 10- μ F and two 0.1- μ F power-supply decoupling capacitors should be placed as near to the power-supply pins as possible.
6. Two 0.1- μ F capacitors should be placed between the CM input pins and ground. This limits noise coupled into the pins. One each should be placed to ground near pin 4 and pin 9.
7. It is recommended to split the ground plane on layer 2 (L2) as shown below and to use a solid ground on layer 3 (L3). A single-point connection should be used between each split section on L2 and L3.
8. A single-point connection to ground on L2 is recommended for the input termination resistors R1 and R2. This should be applied to the input gain resistors if termination is not used.
9. The THS4509 recommended PCB footprint is shown in Figure 91.

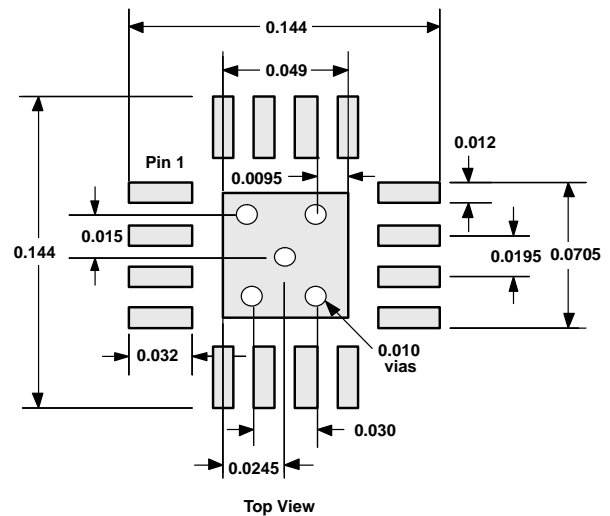

Figure 91. QFN Etch and Via Pattern

THS4509 EVM

Figure 92 is the THS4509 EVAL1 EVM schematic, layers 1 through 4 of the PCB are shown Figure 93, and Table 4 is the bill of material for the EVM as supplied from TI.

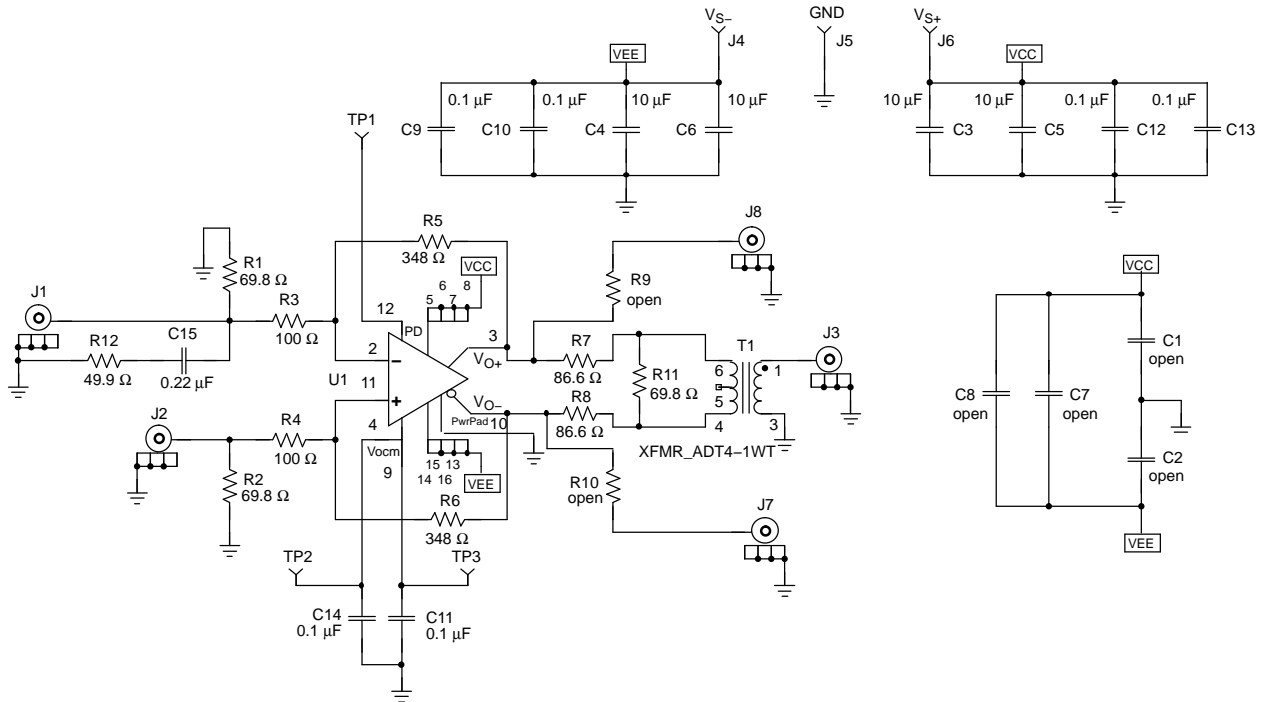

Figure 92. THS4509 EVAL1 EVM Schematic

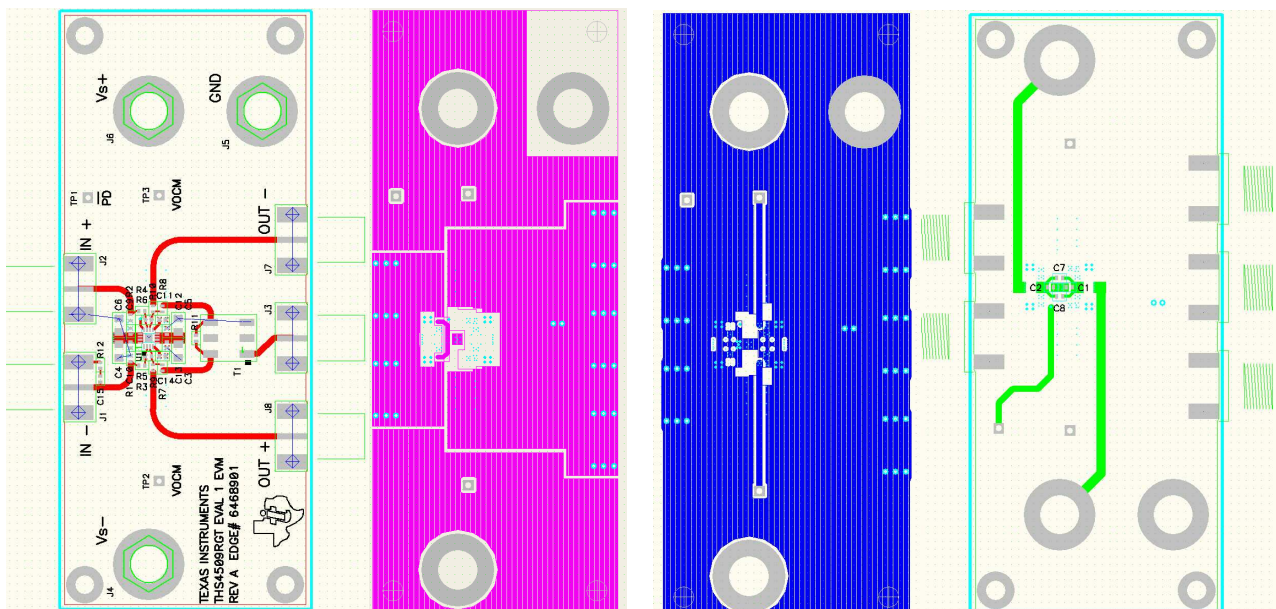

Figure 93. THS4509 EVAL1 EVM Layer 1 through 4

Table 4. THS4509 EVAL1 EVM Bill of Materials

ITEM	DESCRIPTION	SMD SIZE	REFERENCE DESIGNATOR	PCB QTY	MANUFACTURER'S PART NUMBER
1	CAP, 10.0 μ F, Ceramic, X5R, 6.3V	0805	C3, C4, C5, C6	4	(AVX) 08056D106KAT2A
2	CAP, 0.1 μ F, Ceramic, X5R, 10V	0402	C9, C10, C11, C12, C13, C14	6	(AVX) 0402ZD104KAT2A
3	CAP, 0.22 μ F, Ceramic, X5R, 6.3V	0402	C15	1	(AVX) 04026D224KAT2A
4	OPEN	0402	C1, C2, C7, C8	4	
5	OPEN	0402	R9, R10	2	
6	Resistor, 49.9 Ω , 1/16W, 1%	0402	R12	1	(KOA) RK73H1ETTP49R9F
8	Resistor, 69.8 Ω , 1/16W, 1%	0402	R1, R2, R11	3	(KOA) RK73H1ETTP69R8F
9	Resistor, 86.6 Ω , 1/16W, 1%	0402	R7, R8	2	(KOA) RK73H1ETTP86R6F
10	Resistor, 100 Ω , 1/16W, 1%	0402	R3, R4	2	(KOA) RK73H1ETTP1000F
11	Resistor, 348 Ω , 1/16W, 1%	0402	R5, R6	2	(KOA) RK73H1ETTP3480F
12	Transformer, RF		T1	1	(MINI-CIRCUITS) ADT1-1WT
13	Jack, banana receptance, 0.25" diameter hole		J4, J5, J6	3	(HH SMITH) 101
14	OPEN		J1, J7, J8	3	
15	Connector, edge, SMA PCB Jack		J2, J3	2	(JOHNSON) 142-0701-801
16	Test point, Red		TP1, TP2, TP3	3	(KEYSTONE) 5000
17	IC, THS4509		U1	1	(TI) THS4509RGT
18	Standoff, 4-40 HEX, 0.625" length			4	(KEYSTONE) 1808
19	SCREW, PHILLIPS, 4-40, 0.250"			4	SHR-0440-016-SN
20	Printed circuit board			1	(TI) EDGE# 6468901

THERMAL INFORMATION

This package incorporates an exposed thermal pad that is designed to be attached directly to an external heatsink. The thermal pad must be soldered directly to the printed circuit board (PCB), the PCB can be used as a heatsink. In addition, through the use of thermal vias, the thermal pad can be attached directly to a ground plane or special heatsink structure designed into the PCB. This design optimizes the heat transfer from the integrated circuit (IC).

For information on the Quad Flatpack No-Lead (QFN) package and its advantages, refer to Application Report, Quad Flatpack No-Lead Logic Packages, Texas Instruments Literature No. SCBA017. This document is available at www.ti.com.

The exposed thermal pad dimensions for this package are shown in the following illustration.

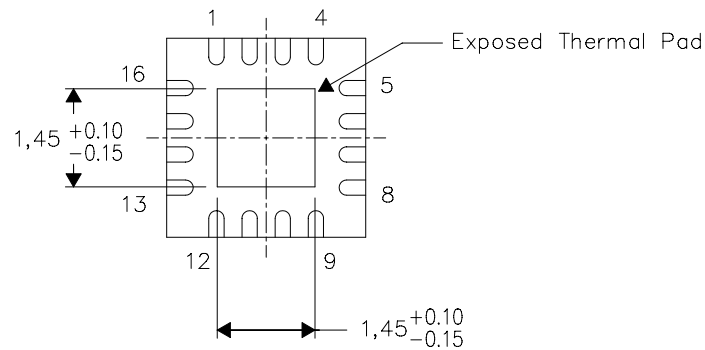

Bottom View

NOTE: All linear dimensions are in millimeters

Exposed Thermal Pad Dimensions

PACKAGING INFORMATION

Orderable Device	Status ⁽¹⁾	Package Type	Package Drawing	Pins	Package Qty	Eco Plan ⁽²⁾	Lead/Ball Finish	MSL Peak Temp ⁽³⁾
THS4509RGTR	ACTIVE	QFN	RGT	16	3000	Green (RoHS & no Sb/Br)	CU NIPDAU	Level-2-260C-1 YEAR
THS4509RGTT	ACTIVE	QFN	RGT	16	250	Green (RoHS & no Sb/Br)	CU NIPDAU	Level-2-260C-1 YEAR

⁽¹⁾ The marketing status values are defined as follows:

ACTIVE: Product device recommended for new designs.

LIFEBUY: TI has announced that the device will be discontinued, and a lifetime-buy period is in effect.

NRND: Not recommended for new designs. Device is in production to support existing customers, but TI does not recommend using this part in a new design.

PREVIEW: Device has been announced but is not in production. Samples may or may not be available.

OBsolete: TI has discontinued the production of the device.

⁽²⁾ Eco Plan - May not be currently available - please check <http://www.ti.com/productcontent> for the latest availability information and additional product content details.

None: Not yet available Lead (Pb-Free).

Pb-Free (RoHS): TI's terms "Lead-Free" or "Pb-Free" mean semiconductor products that are compatible with the current RoHS requirements for all 6 substances, including the requirement that lead not exceed 0.1% by weight in homogeneous materials. Where designed to be soldered at high temperatures, TI Pb-Free products are suitable for use in specified lead-free processes.

Green (RoHS & no Sb/Br): TI defines "Green" to mean "Pb-Free" and in addition, uses package materials that do not contain halogens, including bromine (Br) or antimony (Sb) above 0.1% of total product weight.

⁽³⁾ MSL, Peak Temp. -- The Moisture Sensitivity Level rating according to the JEDEC industry standard classifications, and peak solder temperature.

Important Information and Disclaimer: The information provided on this page represents TI's knowledge and belief as of the date that it is provided. TI bases its knowledge and belief on information provided by third parties, and makes no representation or warranty as to the accuracy of such information. Efforts are underway to better integrate information from third parties. TI has taken and continues to take reasonable steps to provide representative and accurate information but may not have conducted destructive testing or chemical analysis on incoming materials and chemicals. TI and TI suppliers consider certain information to be proprietary, and thus CAS numbers and other limited information may not be available for release.

In no event shall TI's liability arising out of such information exceed the total purchase price of the TI part(s) at issue in this document sold by TI to Customer on an annual basis.

IMPORTANT NOTICE

Texas Instruments Incorporated and its subsidiaries (TI) reserve the right to make corrections, modifications, enhancements, improvements, and other changes to its products and services at any time and to discontinue any product or service without notice. Customers should obtain the latest relevant information before placing orders and should verify that such information is current and complete. All products are sold subject to TI's terms and conditions of sale supplied at the time of order acknowledgment.

TI warrants performance of its hardware products to the specifications applicable at the time of sale in accordance with TI's standard warranty. Testing and other quality control techniques are used to the extent TI deems necessary to support this warranty. Except where mandated by government requirements, testing of all parameters of each product is not necessarily performed.

TI assumes no liability for applications assistance or customer product design. Customers are responsible for their products and applications using TI components. To minimize the risks associated with customer products and applications, customers should provide adequate design and operating safeguards.

TI does not warrant or represent that any license, either express or implied, is granted under any TI patent right, copyright, mask work right, or other TI intellectual property right relating to any combination, machine, or process in which TI products or services are used. Information published by TI regarding third-party products or services does not constitute a license from TI to use such products or services or a warranty or endorsement thereof. Use of such information may require a license from a third party under the patents or other intellectual property of the third party, or a license from TI under the patents or other intellectual property of TI.

Reproduction of information in TI data books or data sheets is permissible only if reproduction is without alteration and is accompanied by all associated warranties, conditions, limitations, and notices. Reproduction of this information with alteration is an unfair and deceptive business practice. TI is not responsible or liable for such altered documentation.

Resale of TI products or services with statements different from or beyond the parameters stated by TI for that product or service voids all express and any implied warranties for the associated TI product or service and is an unfair and deceptive business practice. TI is not responsible or liable for any such statements.

Following are URLs where you can obtain information on other Texas Instruments products and application solutions:

Products		Applications	
Amplifiers	amplifier.ti.com	Audio	www.ti.com/audio
Data Converters	dataconverter.ti.com	Automotive	www.ti.com/automotive
DSP	dsp.ti.com	Broadband	www.ti.com/broadband
Interface	interface.ti.com	Digital Control	www.ti.com/digitalcontrol
Logic	logic.ti.com	Military	www.ti.com/military
Power Mgmt	power.ti.com	Optical Networking	www.ti.com/opticalnetwork
Microcontrollers	microcontroller.ti.com	Security	www.ti.com/security
		Telephony	www.ti.com/telephony
		Video & Imaging	www.ti.com/video
		Wireless	www.ti.com/wireless

Mailing Address: Texas Instruments
Post Office Box 655303 Dallas, Texas 75265