



Voltage Mode PWM Controller with EMI Reduction

General Description

ASM8P18xx is a high performance, adjustable frequency, PWM controller with an integrated spread spectrum modulator for EMI reduction. It contains all the functions of a standard PWM controller along with a user configurable spread spectrum modulation with adjustable spread. ASM8P18xx allows significant system cost savings by reducing the number of PCB layers and shielding that are traditionally required to pass EMI regulation.

ASM8P18xx is the industry's first general purpose EMI reduction IC, specifically designed for use in SMPS systems. ASM8P18xx is compatible to any other 3842 PWM controllers.

ASM8P18xx is capable of driving 1A maximum current output and it covers a wide supply voltage range from 7V DC to 30V DC. The PWM frequency is selectable from 40 KHz to 400 KHz.

ASM8P18xx provides under voltage lockout, thermal shutdown, overload, and undercurrent protection. It is available in 8-pin MicroSO, P-DIP and SOIC package.

Features

- 30V maximum operating voltage with CMOS technology
- Adjustable PWM frequencies (40 KHz to 400 KHz)
- Maximum Output drive current of 1A.
- Wide duty cycle range (0% minimum to 95% maximum)
- Spread spectrum modulation with adjustable spread.
- Under voltage lockout with hysteresis.
- Low startup current: 275 μ A maximum
- Pin compatible with industry standard 3842 PWM controller.
- Temperature range -40°C to $+85^{\circ}\text{C}$.
- Thermal shutdown, overload and undercurrent protection.
- Frequency skip mode.
- Available in 8-pin plastic MicroSO, P-DIP and SOIC packages.

Applications

- Off-line converter
- DC-DC converter
- Monitor power supply
- Computer/DVD/STB power supply
- Wireless base station power supply
- Telecom power supply

Typical Operating Circuit

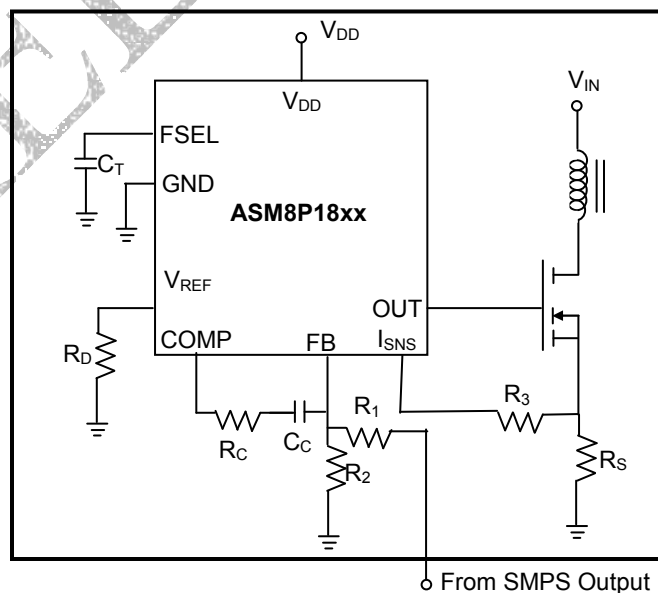



rev 0.6

Logic Block Diagram

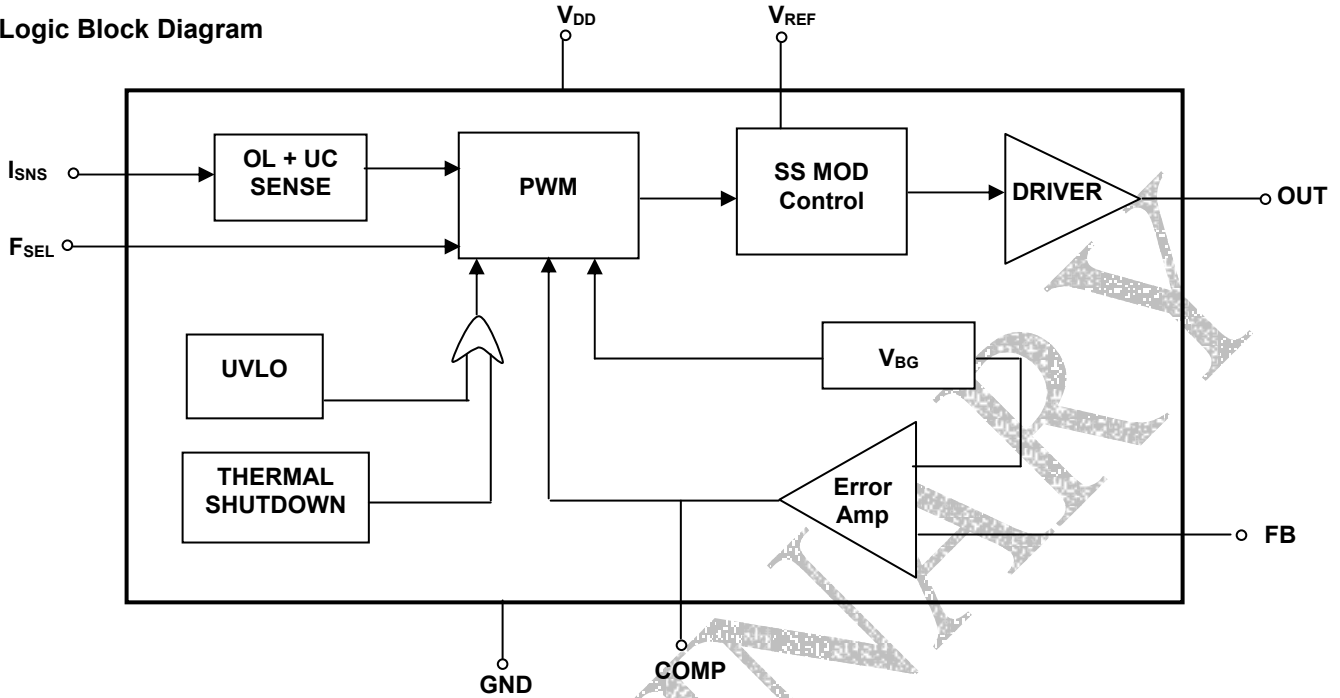

Pin Diagram

8-Pin MicroSO, P-DIP and SOIC

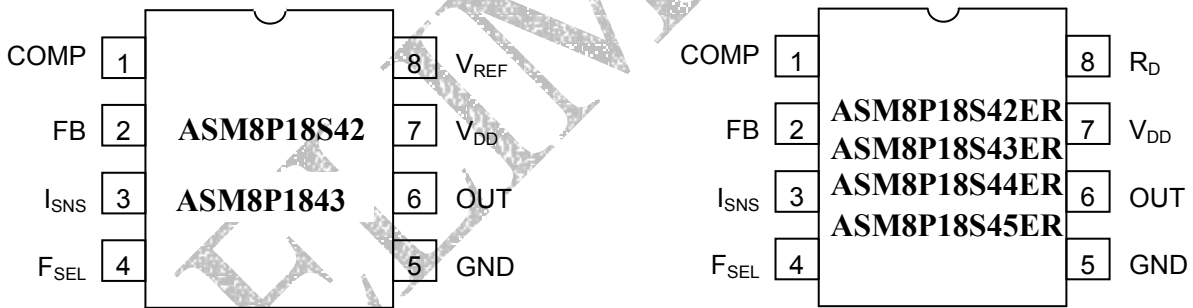

Pin Description

Pin #	Pin Name	Function
1	COMP	Input of the PWM Comparator and output of the error amplifier
2	FB	Feedback, inverting input of the error amplifier
3	Isns	Current sense comparator input
4	FSEL	External capacitor selects PWM frequency
5	GND	Ground
6	OUT	SS modulated PWM output
7	VDD	Supply voltage
8	VREF/ RD	5V output for ASM8P18S42 and ASM8P1843 parts. External resistor "RD" to GND sets the modulation spread for the parts with ER suffix.



rev 0.6

Application Information

Spread Spectrum Deviation

The deviation can be determined by selecting the proper resistor at V_{REF} to GND for the parts with 'ER' suffix. (Refer "R_D Resistor Vs. % Modulation Depth Plot" for resistor selection)

PWM Frequency

The PWM frequency can be determined by selecting the proper capacitance (C_T) at the FSEL pin.

Start-up Current

ASM8P18xx allows a substantial reduction in the start up current. Low start up current allows high resistance, lower wattage start-up resistor, to supply controller start up power.

Under Voltage Lockout (UVLO)

When the power supply voltage is below the start up threshold voltage, internal circuitry puts the output into low impedance state and sets the output to zero.

Absolute Maximum Ratings

Symbol	Parameter	Min	Max	Units
V_{DD}	Supply Voltage		30	V
I_{DD}	Supply Current		TBD*	mA
I_{OUT}	Maximum Output Current		1	A
I_{SNS}	Current Sense Inputs and feedback I_{SNS} , FB, COMP		5	V
V_{REF}	Reference Voltage		6	V
V_{OSC}	Oscillator Voltage		4	V
V_{OUT}	Output Voltage		30	V
	Operation Junction Temperature	-45	150	°C
	Storage Temperature	-65	150	°C
	Lead Soldering Temperature (10 Seconds)		300	°C
	Static Discharge Voltage MIL-STD-883		2	KV

*Maximum output voltage = 30V

Thermal Shutdown

The output of ASM8P18xx goes down to zero when the junction temperature of the device rises above 155°C. The device automatically resumes operation when temperature drops to 126°C. This protects the device from thermal breakdown.

Overload and under current protection

ASM8P18xx provides Cycle by cycle current limit and pulls down PWM output to low as soon as I_{SNS} pin senses a peak voltage of 1V, with a delay to output of 125 nS maximum.

At no load condition when the device senses the peak voltage level of less than 0.1V at I_{SNS} pin for a period of 200mS, the oscillator enters in to cycle skip mode. Normal condition is restored once I_{SNS} increases beyond 0.1V for more than three cycles. Details of cycle skip for different options are provided in the Electrical Characteristics table.



rev 0.6

Electrical Characteristics

Unless otherwise noted, $V_{DD}=15V$, Capacitor on $F_{SEL} = 330pf$, $I_{SENS} = 0.5V$. Specifications are over the $-40^{\circ}C$ to $+85^{\circ}C$ ambient temperature range. Typical values are at $25^{\circ}C$.

Parameter	Symbol	Conditions	Min	Typ	Max	Units
REFERENCE SECTION						
ASM8P18S42 & ASM8P1843						
Output voltage	V_{REF}	$T_A = +25^{\circ}C$, $I_{OUT} = 1mA$	4.90	5.00	5.1	V
Line Regulation	ΔV_{REF}	$12V < V_{DD} < 18V$, $I_{OUT} = 5\mu A$		25		mV
Total Reference variation		Line, Temperature			0.7	%
Temperature Stability	TC_{REF}			0.5		mV/ $^{\circ}C$
Load Regulation (ASM8P1843)		$1mA < I_o < 20mA$		25		mV
ERROR AMPLIFIER SECTION						
Input Bias Current	I_{BIAS}			-20		μA
Input Voltage	V_I	$V_{pin1} = 1.25V$	1.2	1.25	1.3	V
Open Loop Voltage Gain	A_{VOL}			65		dB
Power Supply Rejection Ratio	PSRR	$V_{START} < V_{CC} < V_{CC} \max$		80		dB
Output Sink Current	I_{OL}	$V_{FB} = 1.32V$, $V_{COMP} = 0.15V$		-1.5		mA
Output Source Current	I_{OH}	$V_{FB} = 1.18V$, $V_{COMP} = 4.17V$		0.3		mA
High Output Voltage	V_{OH}	$V_{FB} = 1.25V$, $R_L = 15K\Omega$	4.17			V
Low Output Voltage	V_{OL}	$V_{FB} = 1.25V$		0.15		V
CURRENT SENSE SECTION						
Over Current Protection Threshold	$V_{I(MAX)}$	$FB = 0V$ ($V_{COMP} = 5V$)	0.90	1.00	1.10	V
Delay to output	T_{PD}	$V_{FB} = 0V$, $I_{SNS} = 0$ to $2V$			125	ns
Under Current Sense Period	T_{UCS}			200		ms
Under Current Recovery Period	T_{UCSD}			3		Cycles of PWM Frequency
Cycle Skip	Cycle Skip condition: $I_{SENS} \leq 0.1V$	ASM8P18S42, ASM8P18S42ER		1/4		$x f_s$
		ASM8P1843 ASM8P18S43ER ASM8P18S44ER		1/10		
		ASM8P18S45ER		No Skip		
OUTPUT SECTION						
Low Output Voltage	V_{OL}	$I_{SINK} = 50mA$ $I_{SINK} = 200mA$	At $V_{DD} = 15V$	0.128	0.470	V
High Output Voltage	V_{OH}	$I_{SOURCE} = 50mA$ $I_{SOURCE} = 200mA$		14.71	13.77	V
On Resistance, High	$R_{DS(ON)H}$	$I_{SOURCE} = 0.2A$		6.5		Ω
On Resistance, Low	$R_{DS(ON)L}$	$I_{SINK} = 0.2A$		2.5		Ω



rev 0.6

Parameter	Symbol	Conditions	Min	Typ	Max	Units
Rise Time	t_R	$T_A = 25^\circ\text{C}$, $C_L = 1\text{nF}$	30			nS
Fall Time	t_F	$T_A = 25^\circ\text{C}$, $C_L = 1\text{nF}$	30			nS
Shoot Through Current				0		
UVLO SECTION						
Start threshold	$V_{th(START)}$	ASM8P1843, ASM8P18S43ER, ASM8P18S45ER,		7.8		V
		ASM8P18S42, ASM8P18S42ER ASM8P18S44ER		15.4		
Stop Threshold	$V_{th(STOP)}$	ASM8P1843, ASM8P18S43ER, ASM8P18S45ER		6.7		V
		ASM8P18S42, ASM8P18S42ER, ASM8P18S44ER		10.2		
PWM SECTION						
PWM frequency	f_s		40		400	kHz
Duty Cycle Range		ASM8P18S44ER, ASM8P18S45ER	0		50	%
		ASM8P18S42, ASM8P18S42ER, ASM8P1843, ASM8P18S43ER	0		95	
TOTAL DEVICE						
Start up Current	I_{ST}				275	μA
Peak Output Current	$I_{OUT(PK)}$			1000		mA
Operating Current	$I_{CC(OPR)}$	$V_{FB} = 0$; $I_{SNS} = 0.5$; $V_{DD} = 15\text{V}$		5	6	mA
Thermal Shutdown	V_Z	Junction Temp		155		$^\circ\text{C}$
Thermal Recovery				126		$^\circ\text{C}$
SPREAD SPECTRUM SECTION						
Modulation Rate		ASM8P18S43ER, ASM8P18S45ER		1/20		of Switching Frequency (KHz)
		ASM8P18S42, ASM8P18S42ER, ASM8P18S44ER		1/10		
Modulation Depth		Refer R_D Resistor Vs. % Modulation Depth Plot				
OSCILLATOR SECTION						
Frequency change with Voltage	$Df/d V_{CC}$			0.04	0.05	%
Oscillator Amplitude					1.66	V (Pk-Pk)
Temperature Stability	T_{OSC}			0.1		$\%/^\circ\text{C}$



Frequency Selection Curve

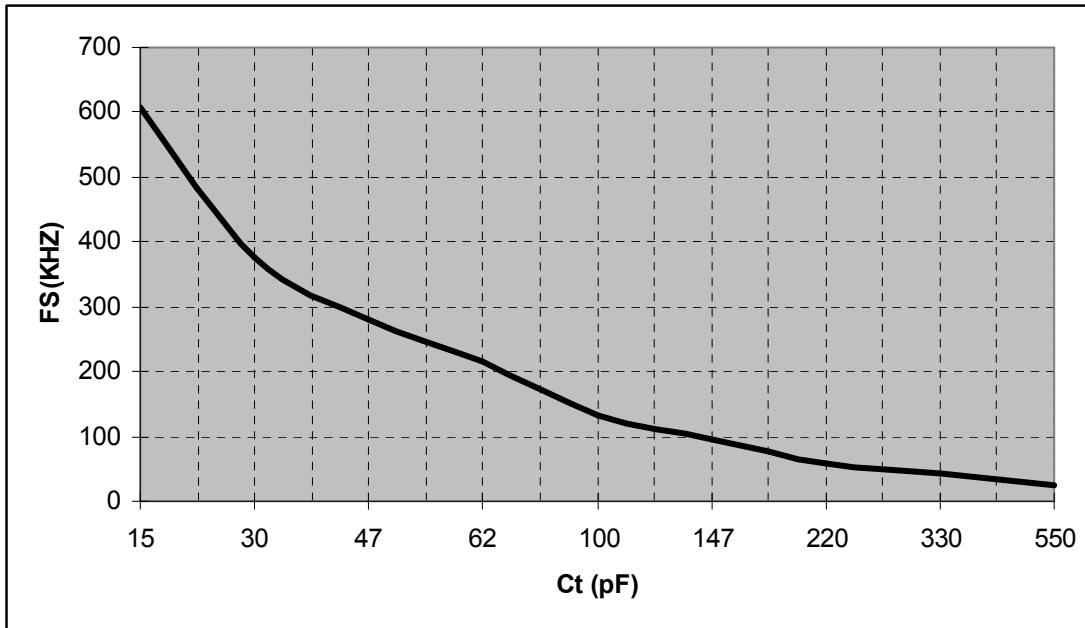

R_D Resistor vs % Modulation Depth Plot

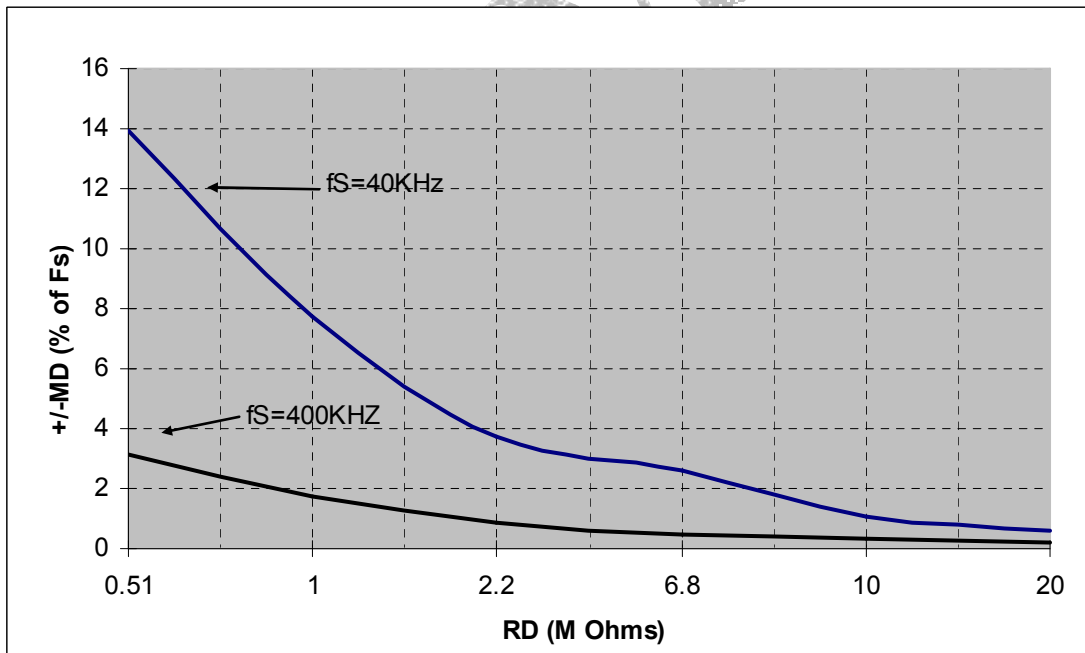



Package Information

8-lead MSOP Package

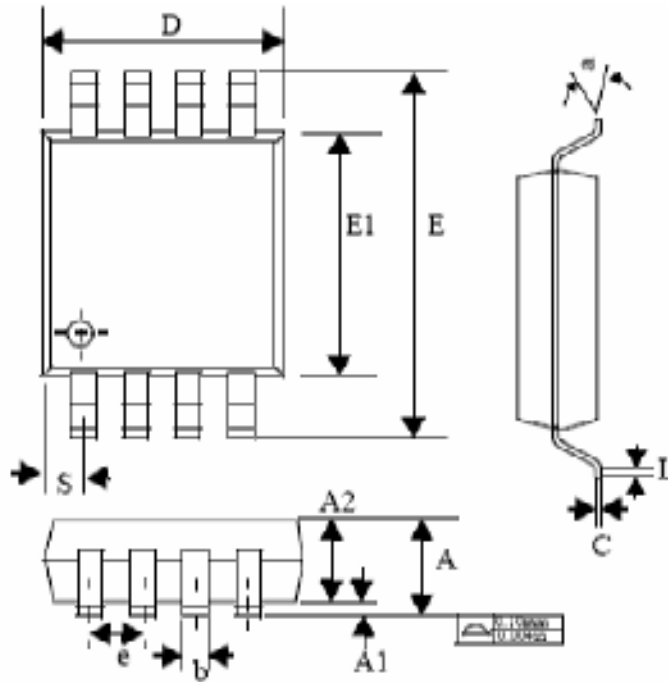

Symbol	Dimensions			
	Inches		Millimeters	
	Min	Max	Min	Max
A	0.032	0.044	0.81	1.10
A1	0.002	0.006	0.05	0.15
A2	0.030	0.038	0.76	0.97
b	0.012 BSC		0.30 BSC	
C	0.004	0.008	0.10	0.20
D	0.114	0.122	2.90	3.10
e	0.0256 BSC		0.65 BSC	
E1	0.114	0.122	2.90	3.10
E	0.184	0.200	4.67	5.08
L	0.016	0.026	0.41	0.66
θ	0°	6°	0°	6°
S	0.0206 BSC		0.52 BSC	



8-lead (150-mil) SOIC Package

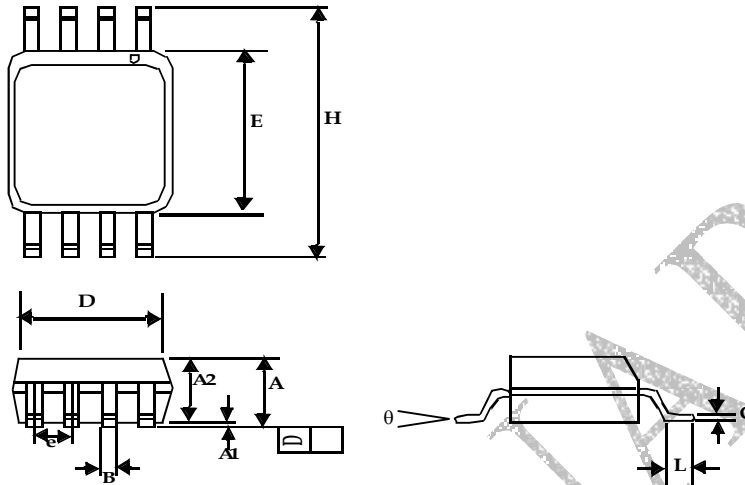

Symbol	Dimensions			
	Inches		Millimeters	
	Min	Max	Min	Max
A1	0.004	0.010	0.10	0.25
A	0.053	0.069	1.35	1.75
A2	0.049	0.059	1.25	1.50
B	0.012	0.020	0.31	0.51
C	0.007	0.010	0.18	0.25
D	0.193 BSC		4.90 BSC	
E	0.154 BSC		3.91 BSC	
e	0.050 BSC		1.27 BSC	
H	0.236 BSC		6.00 BSC	
L	0.016	0.050	0.41	1.27
θ	0°	8°	0°	8°



8-lead PDIP Package

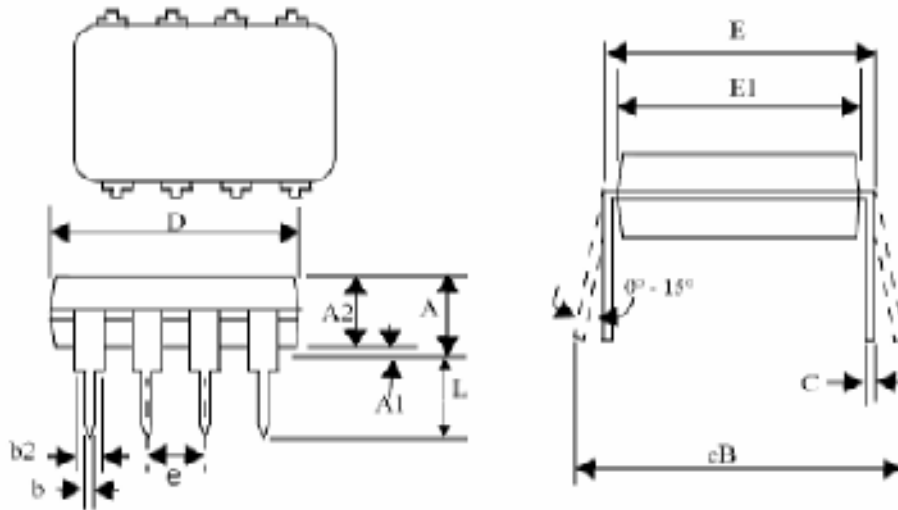

Symbol	Dimensions			
	Inches		Millimeters	
	Min	Max	Min	Max
A		0.210		5.33
A1	0.015		0.38	
A2	0.115	0.195	2.92	4.95
b	0.014	0.022	0.36	0.56
b2	0.045	0.070	1.14	1.78
C	0.008	0.014	0.20	0.36
D	0.355	0.400	9.02	10.16
E	0.300	0.325	7.62	8.26
E1	0.240	0.280	6.10	7.11
e	0.10 BSC		2.54 BSC	
eB		0.430		10.92
L	0.115	0.150	2.92	3.81



Ordering Information

ASM Ordering Part Number	Package	Operating Temp Range	Start-up Voltage	Minimum Operating Voltage	Maximum Duty Cycle	Modulation Depth Control	Peak Output Current	Package Top Mark
ASM8118S42ERF-08-Px	8-PDIP	-45 to 85°C	15.4V	10.2V	95	External R	1A	8118S42ERF
ASM8118S42ERF-08-Mx	8-MSOP	-45 to 85°C	15.4V	10.2V	95	External R	1A	8118S42ERF
ASM8118S42ERF-08-Sx	8-SOIC	-45 to 85°C	15.4V	10.2V	95	External R	1A	8118S42ERF
ASM8P18S42ERF-08-Px	8-PDIP	0 to 70°C	15.4V	10.2V	95	External R	1A	8P18S42ERF
ASM8P18S42ERF-08-Mx	8-MSOP	0 to 70°C	15.4V	10.2V	95	External R	1A	8P18S42ERF
ASM8P18S42ERF-08-Sx	8-SOIC	0 to 70°C	15.4V	10.2V	95	External R	1A	8P18S42ERF
ASM8118S43ERF-08-Px	8-PDIP	-45 to 85°C	7.8V	6.7V	95	External R	1A	8118S43ERF
ASM8118S43ERF-08-Mx	8-MSOP	-45 to 85°C	7.8V	6.7V	95	External R	1A	8118S43ERF
ASM8118S43ERF-08-Sx	8-SOIC	-45 to 85°C	7.8V	6.7V	95	External R	1A	8118S43ERF
ASM8P18S43ERF-08-Px	8-PDIP	0 to 70°C	7.8V	6.7V	95	External R	1A	8P18S43ERF
ASM8P18S43ERF-08-Mx	8-MSOP	0 to 70°C	7.8V	6.7V	95	External R	1A	8P18S43ERF
ASM8P18S43ERF-08-Sx	8-SOIC	0 to 70°C	7.8V	6.7V	95	External R	1A	8P18S43ERF
ASM8118S44ERF-08-Px	8-PDIP	-45 to 85°C	15.4V	10.2V	50	External R	1A	8118S44ERF
ASM8118S44ERF-08-Mx	8-MSOP	-45 to 85°C	15.4V	10.2V	50	External R	1A	8118S44ERF
ASM8118S44ERF-08-Sx	8-SOIC	-45 to 85°C	15.4V	10.2V	50	External R	1A	8118S44ERF
ASM8P18S44ERF-08-Px	8-PDIP	0 to 70°C	15.4V	10.2V	50	External R	1A	8P18S44ERF
ASM8P18S44ERF-08-Mx	8-MSOP	0 to 70°C	15.4V	10.2V	50	External R	1A	8P18S44ERF
ASM8P18S44ERF-08-Sx	8-SOIC	0 to 70°C	15.4V	10.2V	50	External R	1A	8P18S44ERF
ASM8118S45ERF-08-Px	8-PDIP	-45 to 85°C	7.8V	6.7V	50	External R	1A	8118S45ERF
ASM8118S45ERF-08-Mx	8-MSOP	-45 to 85°C	7.8V	6.7V	50	External R	1A	8118S45ERF
ASM8118S45ERF-08-Sx	8-SOIC	-45 to 85°C	7.8V	6.7V	50	External R	1A	8118S45ERF
ASM8P18S45ERF-08-Px	8-PDIP	0 to 70°C	7.8V	6.7V	50	External R	1A	8P18S45ERF
ASM8P18S45ERF-08-Mx	8-MSOP	0 to 70°C	7.8V	6.7V	50	External R	1A	8P18S45ERF
ASM8P18S45ERF-08-Sx	8-SOIC	0 to 70°C	7.8V	6.7V	50	External R	1A	8P18S45ERF
ASM8118S42F-08-Px	8-PDIP	-45 to 85°C	15.4V	10.2V	95	NA	1A	8118S42F
ASM8118S42F-08-Mx	8-MSOP	-45 to 85°C	15.4V	10.2V	95	NA	1A	8118S42F
ASM8118S42F-08-Sx	8-SOIC	-45 to 85°C	15.4V	10.2V	95	NA	1A	8118S42F
ASM8P18S42F-08-Px	8-PDIP	0 to 70°C	15.4V	10.2V	95	NA	1A	8P18S42F
ASM8P18S42F-08-Mx	8-MSOP	0 to 70°C	15.4V	10.2V	95	NA	1A	8P18S42F
ASM8P18S42F-08-Sx	8-SOIC	0 to 70°C	15.4V	10.2V	95	NA	1A	8P18S42F
ASM811843F-08-Px	8-PDIP	-45 to 85°C	7.8V	6.7V	95	NA	1A	811843F
ASM811843F-08-Mx	8-MSOP	-45 to 85°C	7.8V	6.7V	95	NA	1A	811843F
ASM811843F-08-Sx	8-SOIC	-45 to 85°C	7.8V	6.7V	95	NA	1A	811843F
ASM8P1843F-08-Px	8-PDIP	0 to 70°C	7.8V	6.7V	95	NA	1A	8P1843F
ASM8P1843F-08-Mx	8-MSOP	0 to 70°C	7.8V	6.7V	95	NA	1A	8P1843F
ASM8P1843F-08-Sx	8-SOIC	0 to 70°C	7.8V	6.7V	95	NA	1A	8P1843F

Note: All Alliance Semiconductor Lead Free Parts are RoHS Compliant. All parts are Lead Free by default. Contact factory for Non Lead Free Parts.

Licensed under US Patent numbers 5,488,627 and 5,631,921.

June 2005



ASM8P18S42 / ASM8P18S42ER
ASM8P1843 / ASM8P18S43ER
ASM8P18S44ER / ASM8P18S45ER

rev 0.6



Alliance Semiconductor Corporation
2575, Augustine Drive,
Santa Clara, CA 95054
Tel# 408-855-4900
Fax: 408-855-4999
www.alsc.com

Copyright © Alliance Semiconductor
All Rights Reserved
Preliminary Information
Part Number: ASM8P18S42 / ASM8P18S42ER
ASM8P18S42 / ASM8P18S43ER
ASM8P18S44ER / ASM8P18S45ER
Document Version: v0.6

Note: This product utilizes US Patent # 6,646,463 Impedance Emulator Patent issued to Alliance Semiconductor, dated 11-11-2003

© Copyright 2003 Alliance Semiconductor Corporation. All rights reserved. Our three-point logo, our name and Intelliwatt are trademarks or registered trademarks of Alliance. All other brand and product names may be the trademarks of their respective companies. Alliance reserves the right to make changes to this document and its products at any time without notice. Alliance assumes no responsibility for any errors that may appear in this document. The data contained herein represents Alliance's best data and/or estimates at the time of issuance. Alliance reserves the right to change or correct this data at any time, without notice. If the product described herein is under development, significant changes to these specifications are possible. The information in this product data sheet is intended to be general descriptive information for potential customers and users, and is not intended to operate as, or provide, any guarantee or warranty to any user or customer. Alliance does not assume any responsibility or liability arising out of the application or use of any product described herein, and disclaims any express or implied warranties related to the sale and/or use of Alliance products including liability or warranties related to fitness for a particular purpose, merchantability, or infringement of any intellectual property rights, except as express agreed to in Alliance's Terms and Conditions of Sale (which are available from Alliance). All sales of Alliance products are made exclusively according to Alliance's Terms and Conditions of Sale. The purchase of products from Alliance does not convey a license under any patent rights, copyrights; mask works rights, trademarks, or any other intellectual property rights of Alliance or third parties. Alliance does not authorize its products for use as critical components in life-supporting systems where a malfunction or failure may reasonably be expected to result in significant injury to the user, and the inclusion of Alliance products in such life-supporting systems implies that the manufacturer assumes all risk of such use and agrees to indemnify Alliance against all claims arising from such use.