

DOOR ACTUATOR DRIVER

1 FEATURES

- One full bridge for 6A load ($r_{on} = 150m\Omega$)
- Two half bridges for 3A load ($r_{on} = 300m\Omega$)
- Two half bridges for 1.5A load ($r_{on} = 800m\Omega$)
- One highside driver for 6A load ($r_{on} = 100m\Omega$)
- Four highside drivers for 1.5A load ($r_{on} = 800m\Omega$)
- Programmable Softstart function to drive loads with higher inrush currents (i.e. current $>6A, >3A, >1.5A$)
- Very low current consumption in standby mode $I_S < 6\mu A$, typ. $T_j \leq 85^\circ C$)
- All outputs short circuit protected
- Current monitor output for 300m Ω , 150m Ω and 100m highside drivers
- All outputs over temperature protected
- Open load diagnostic for all outputs
- Overload diagnostic for all outputs
- Separated half bridges for door lock motor
- PWM control of all outputs
- Charge Pump output for reverse polarity protection

2 APPLICATIONS

Door Actuator Driver with bridges for door lock and safe lock, mirror axis control, mirror fold and highside

Figure 1. Package



Table 1. Order Codes

Part Number	Package
L9950	PowerSO36
L9950TR	Tape & Reel

driver for mirror defroster and four 5W-light bulbs.

3 DESCRIPTION

The L9950 is a microcontroller driven multifunctional door actuator driver for automotive applications. Up to five DC motors and five grounded resistive loads can be driven with six half bridges and five highside drivers. The integrated standard serial peripheral interface (SPI) controls all operation modes (forward, reverse, brake and high impedance).

All diagnostic informations are available via SPI.

Figure 2. Block Diagram

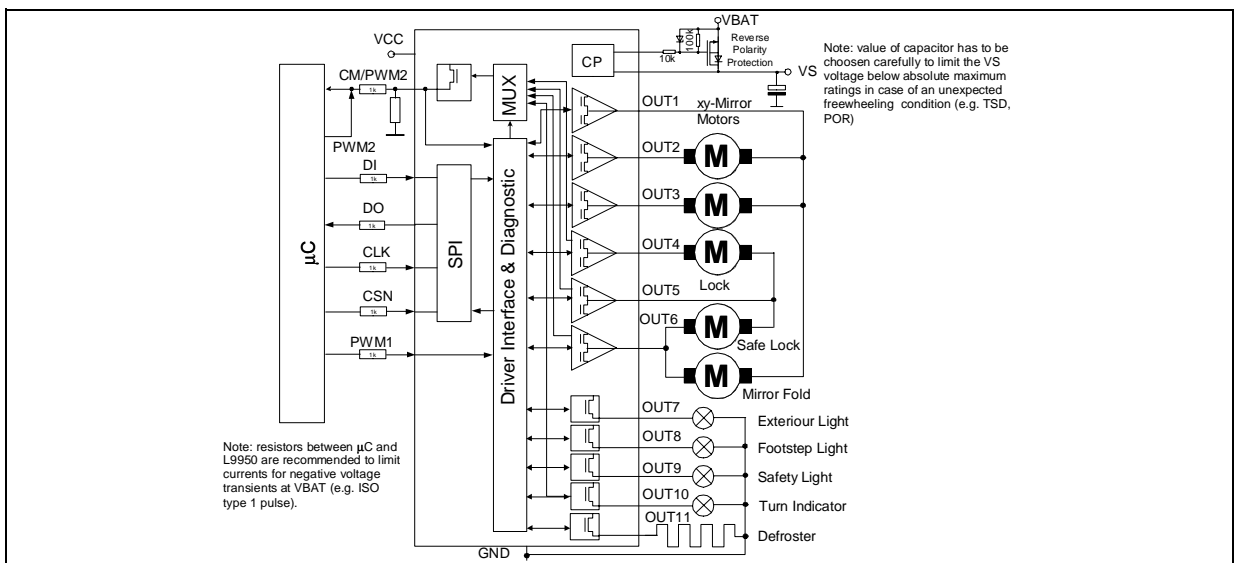

3.1 Dual Power Supply: V_S and V_{CC}

The power supply voltage V_S supplies the half bridges and the highside drivers. An internal charge-pump is used to drive the highside switches. The logic supply voltage V_{CC} (stabilized 5 V) is used for the logic part and the SPI of the device.

Due to the independent logic supply voltage the control and status information will not be lost, if there are temporary spikes or glitches on the power supply voltage. In case of power-on (V_{CC} increases from undervoltage to $V_{POR\ OFF} = 4.2\text{ V}$) the circuit is initialized by an internally generated power-on-reset (POR). If the voltage V_{CC} decreases under the minimum threshold ($V_{POR\ ON} = 3.4\text{ V}$), the outputs are switched to tristate (high impedance) and the status registers are cleared.

3.2 Standby-Mode

The standby mode of the L9950 is activated by clearing the bit 23 of the Input Data Register 0. All latched data will be cleared and the inputs and outputs are switched to high impedance. In the standby mode the current at V_S (V_{CC}) is less than $6\ \mu\text{A}$ ($50\ \mu\text{A}$) for $\text{CSN} = \text{high}$ (DO in tristate). By switching the V_{CC} voltage a very low quiescent current can be achieved. If bit 23 is set, the device will be switched to active mode.

3.3 Inductive Loads

Each half bridge is built by an internally connected highside and a lowside power DMOS transistor. Due to the built-in reverse diodes of the output transistors, inductive loads can be driven at the outputs OUT1 to OUT6 without external free-wheeling diodes. The highside drivers OUT7 to OUT11 are intended to drive resistive loads. Hence only a limited energy ($E < 1\text{ mJ}$) can be dissipated by the internal ESD-diodes in free-wheeling condition. For inductive loads ($L > 100\ \mu\text{H}$) an external free-wheeling diode connected to GND and the corresponding output is needed.

3.4 Diagnostic Functions

All diagnostic functions (over/open load, power supply over-/undervoltage, temperature warning and thermal shutdown) are internally filtered and the condition has to be valid for at least $32\ \mu\text{s}$ (open load: 1 ms , respectively) before the corresponding status bit in the status registers will be set. The filters are used to improve the noise immunity of the device. Open load and temperature warning function are intended for information purpose and will not change the state of the output drivers. On contrary, the overload and thermal shutdown condition will disable the corresponding driver (overload) or all drivers (thermal shutdown), respectively. Without setting the over-current recovery bits in the Input Data Register, the microcontroller has to clear the over-current status bits to reactivate the corresponding drivers.

3.5 Overvoltage and Undervoltage Detection

If the power supply voltage V_S rises above the overvoltage threshold $V_{SOV\ OFF}$ (typical 21 V), the outputs OUT1 to OUT11 are switched to high impedance state to protect the load. When the voltage V_S drops below the undervoltage threshold $V_{SUUV\ OFF}$ (UV-switch-OFF voltage), the output stages are switched to the high impedance to avoid the operation of the power devices without sufficient gate driving voltage (increased power dissipation). If the supply voltage V_S recovers to normal operating voltage the outputs stages return to the programmed state (input register 0: bit 20=0).

If the undervoltage/overvoltage recovery disable bit is set, the automatic turn-on of the drivers is deactivated. The microcontroller needs to clear the status bits to reactivate the drivers. It is recommended to set bit 20 to avoid a possible high current oscillation in case of a shorted output to GND and low battery voltage.

3.6 Temperature Warning and Thermal Shutdown

If junction temperature rises above $T_{j\ TW}$ a temperature warning flag is set and is detectable via the SPI. If junction temperature increases above the second threshold $T_{j\ SD}$, the thermal shutdown bit will be set and power DMOS transistors of all output stages are switched off to protect the device. In order to reactivate the output stages the junction temperature must decrease below $T_{j\ SD} - T_{j\ SD\ HYS}$ and the thermal shutdown bit has to be cleared by the microcontroller.

3.7 Open Load Detection

The open load detection monitors the load current in each activated output stage. If the load current is below the open load detection threshold for at least 1 ms (t_{dOL}) the corresponding open load bit is set in the status register. Due to mechanical/electrical inertia of typical loads a short activation of the outputs (e.g. 3ms) can be used to test the open load status without changing the mechanical/electrical state of the loads.

3.8 Over Load Detection

In case of an over-current condition a flag is set in the status register in the same way as open load detection. If the over-current signal is valid for at least $t_{ISC} = 32 \mu s$, the over-current flag is set and the corresponding driver is switched off to reduce the power dissipation and to protect the integrated circuit. If the over-current recovery bit of the output is zero the microcontroller has to clear the status bits to reactivate the corresponding driver.

3.9 Current monitor

The current monitor output sources a current image at the current monitor output which has a fixed ratio (1/10000) of the instantaneous current of the selected highside driver. The bits 18 and 19 of the Input Data Register 0 control which of the outputs OUT1, OUT4, OUT5, OUT6 and OUT11 will be multiplexed to the current monitor output. The current monitor output allows a more precise analysis of the actual state of the load rather than the detection of an open- or overload condition. For example this can be used to detect the motor state (starting, free-running, stalled). Moreover, it is possible to regulate the power of the defroster more precise by measuring the load current. The current monitor output is bidirectional (c.f. PWM inputs).

3.10 PWM inputs

Each driver has a corresponding PWM enable bit which can be programmed by the SPI interface. If the PWM enable bit is set, the output is controlled by the logically AND-combination of the PWM signal and the output control bit in Input Data Register. The outputs OUT1-OUT8 and OUT11 are controlled by the PWM1 input and the outputs OUT9/10 are controlled by the bidirectional input CM/PMW2. For example, the two PWM inputs can be used to dim two lamps independently by external PWM signals.

3.11 Cross-current protection

The six half-bridges of the device are cross-current protected by an internal delay time. If one driver (LS or HS) is turned-off the activation of the other driver of the same half bridge will be automatically delayed by the cross-current protection time. After the cross-current protection time is expired the slew-rate limited switch-off phase of the driver will be changed to a fast turn-off phase and the opposite driver is turned-on with slew-rate limitation. Due to this behaviour it is always guaranteed that the previously activated driver is totally turned-off before the opposite driver will start to conduct.

3.12 Programmable Softstart Function to drive loads with higher inrush current

Loads with start-up currents higher than the over-current limits (e.g. inrush current of lamps, start current of motors and cold resistance of heaters) can be driven by using the programmable softstart function (i.e. overcurrent recovery mode). Each driver has a corresponding over-current recovery bit. If this bit is set, the device will automatically switch-on the outputs again after a programmable recovery time. The duty cycle in over-current condition can be programmed by the SPI interface to be about 12% or 25%. The PWM modulated current will provide sufficient average current to power up the load (e.g. heat up the bulb) until the load reaches operating condition.

The device itself cannot distinguish between a real overload and a non linear load like a light bulb. A real overload condition can only be qualified by time. As an example the microcontroller can switch on light bulbs by setting the over-current Recovery bit for the first 50ms. After clearing the recovery bit the output will be automatically disabled if the overload condition still exists

Example of programmable softstart function for inductive loads

Figure 3.

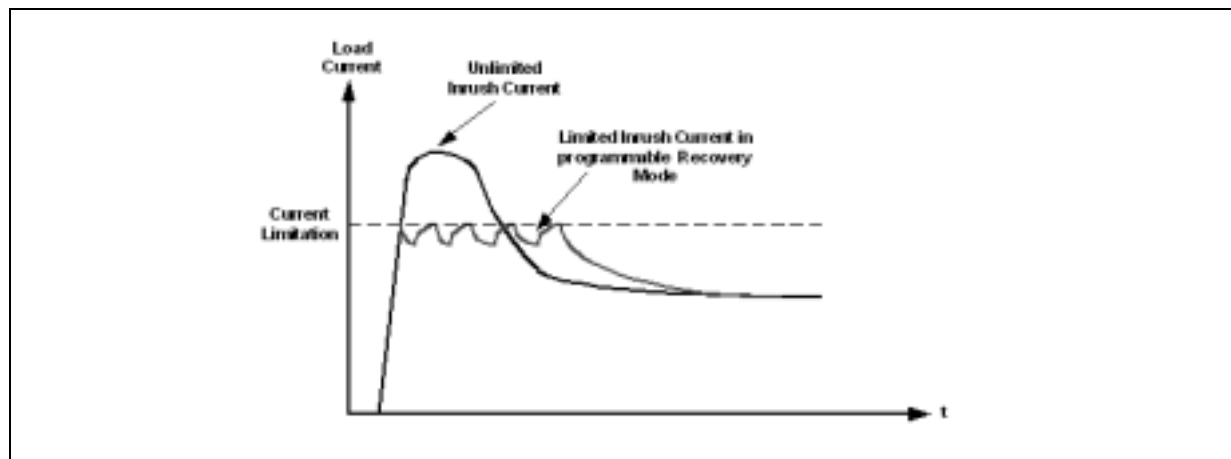

Figure 4. Pin Connection

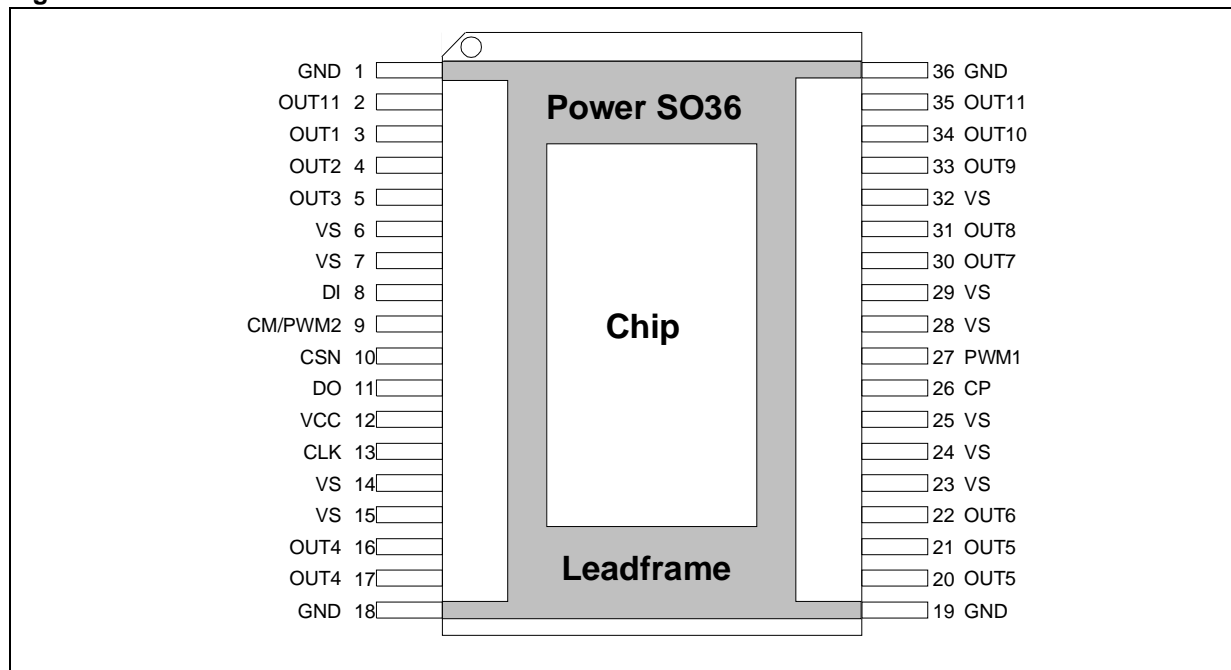

Table 2. Pin Description

Pin	Symbol	Function
1, 18, 19, 36	GND	Ground: Reference potential Important: For the capability of driving the full current at the outputs all pins of GND must be externally connected !
2,35	OUT11	Highside-driver-output 11: The output is built by a highside switch and is intended for resistive loads, hence the internal reverse diode from GND to the output is missing. For ESD reason a diode to GND is present but the energy which can be dissipated is limited. The highside driver is a power DMOS transistor with an internal parasitic reverse diode from the output to VS (bulk-drain-diode). The output is over-current and open load protected. Important: For the capability of driving the full current at the outputs both pins of OUT11 must be externally connected !
3 4 5	OUT1 OUT2 OUT3	Halfbridge-output 1,2,3: The output is built by a highside and a lowside switch, which are internally connected. The output stage of both switches is a power DMOS transistor. Each driver has an internal parasitic reverse diode (bulk-drain-diode: highside driver from output to VS, lowside driver from GND to output). This output is over-current and open load protected.
6, 7, 14, 15, 23, 24, 25, 28, 29, 32	VS	Power supply voltage (external reverse protection required): For this input a ceramic capacitor as close as possible to GND is recommended. Important: For the capability of driving the full current at the outputs all pins of VS must be externally connected !
8	DI	Serial data input: The input requires CMOS logic levels and receives serial data from the microcontroller. The data is an 24bit control word and the least significant bit (LSB, bit 0) is transferred first.
9	CM/PWM2	Current monitor output/PWM2 input: Depending on the selected multiplexer bits of Input Data Register this output sources an image of the instant current through the corresponding highside driver with a ratio of 1/ 10.000. This pin is bidirectional. The microcontroller can overdrive the current monitor signal to provide a second PWM input for the outputs OUT9 and OUT10.
10	CSN	Chip Select Not input / Testmode : This input is low active and requires CMOS logic levels. The serial data transfer between L9950 and micro controller is enabled by pulling the input CSN to low level. If an input voltage of more than 7.5V is applied to CSN pin the L9950 will be switched into a test mode.
11	DO	Serial data output: The diagnosis data is available via the SPI and this tristate-output. The output will remain in tristate, if the chip is not selected by the input CSN (CSN = high)
12	VCC	Logic supply voltage: For this input a ceramic capacitor as close as possible to GND is recommended.
13	CLK	Serial clock input: This input controls the internal shift register of the SPI and requires CMOS logic levels.
16,17, 20,21, 22	OUT4 OUT5 OUT6	Halfbridge-output 4,5,6: → see OUT1 (pin 3). Important: For the capability of driving the full current at the outputs both pins of OUT4 (OUT5, respectively) must be externally connected !
26	CP	Charge Pump Output: This output is provided to drive the gate of an external n-channel power MOS used for reverse polarity protection (see FIGURE 1)
27	PWM1	PWM1 input: This input signal can be used to control the drivers OUT1-OUT8 and OUT11 by an external PWM signal.
30 31 33 34	OUT7, OUT8, OUT9, OUT10	Highside-driver-output 7,8,9,10: The output is built by a highside switch and is intended for resistive loads, hence the internal reverse diode from GND to the output is missing. For ESD reason a diode to GND is present but the energy which can be dissipated is limited. The highside driver is a power DMOS transistor with an internal parasitic reverse diode from the output to VS (bulk-drain-diode). The output is over-current and open load protected.

Table 3. Absolute Maximum Ratings

Symbol	Parameter	Value	Unit
V_S	DC supply voltage	-0.3 to 28	V
	single pulse $t_{max} < 400ms$	40	V
V_{CC}	stabilized supply voltage, logic supply	-0.3 to 5.5	V
V_{DI} , V_{DO} , V_{CLK} , V_{CSN} , V_{pwm1}	digital input / output voltage	-0.3 to $V_{CC} + 0.3$	V
V_{CM}	current monitor output	-0.3 to $V_{CC} + 0.3$	V
V_{CP}	charge pump output	-25 to $V_S + 11$	V
$I_{OUT1,2,3,6,7,8,9,10}$	output current	± 5	A
$I_{OUT4,5,11}$	output current	± 10	A

Note All maximum ratings are absolute ratings. Leaving the limitation of any of these values may cause an irreversible damage of the integrated circuit !

Table 4. ESD Protection

Parameter	Value	Unit
All pins	± 4 ¹	kV
output pins: OUT1 - OUT11	± 8 ²	kV

Note: 1. HBM according to CDF-AEC-Q100-002
2. HBM with all unzapped pins grounded

Table 5. Thermal Data

Symbol	Parameter	Value	Unit
T_j	Operating junction temperature	-40 to 150	°C

Table 6. Temperature warning and thermal shutdown

Symbol	Parameter	Min.	Typ.	Max.	Unit
$T_{jTW ON}$	temperature warning threshold junction temperature	T_j increasing		150	°C
$T_{jTW OFF}$	temperature warning threshold junction temperature	T_j decreasing	130		°C
$T_{jTW HYS}$	temperature warning hysteresis		5		K
$T_{jSD ON}$	thermal shutdown threshold junction temperature	T_j increasing		170	°C
$T_{jSD OFF}$	thermal shutdown threshold junction temperature	T_j decreasing	150		°C
$T_{jSD HYS}$	thermal shutdown hysteresis		5		K

Figure 5. Thermal Data Of Package

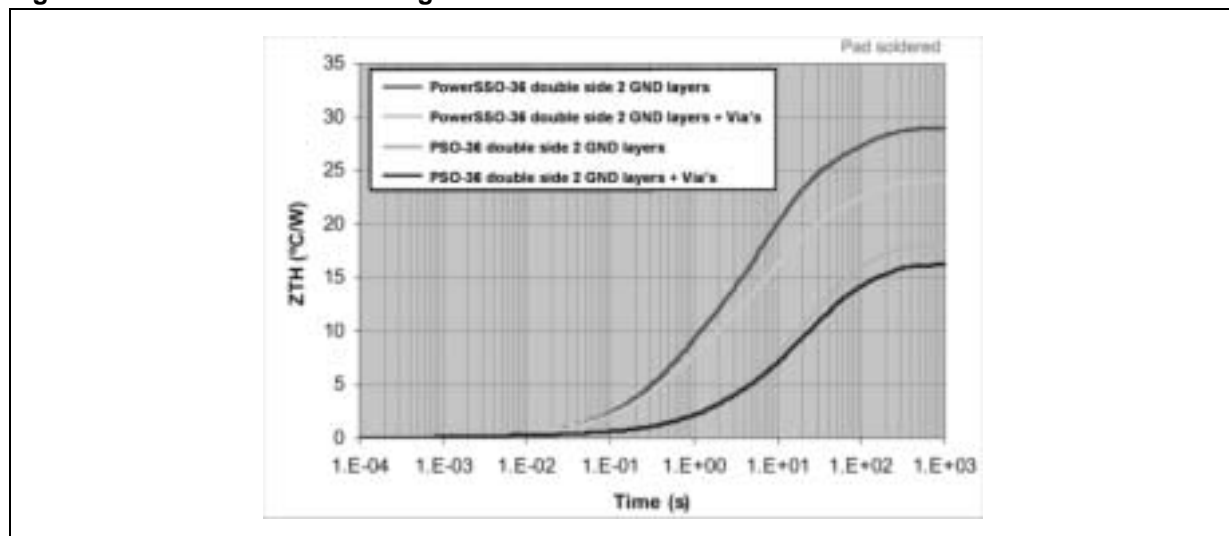

Table 7. ELECTRICAL CHARACTERISTICS

($V_S = 8$ to $16V$, $V_{CC} = 4.5$ to $5.3V$, $T_j = -40$ to $150^\circ C$, unless otherwise specified. The voltages are referred to GND and currents are assumed positive, when the current flows into the pin)

Symbol	Parameter	Test Condition	Min.	Typ.	Max.	Unit
Supply						
V_S	operating supply voltage range		7		28	V
I_S	VS DC supply current	$V_S = 16V$, $V_{CC} = 5.3V$ active mode OUT1 - OUT11 floating		7	20	mA
	VS quiescent supply current	$V_S = 16V$, $V_{CC} = 0V$ standby mode OUT1 - OUT11 floating $T_{test} = -40^\circ C, 25^\circ C$		4	12	μA
I_{CC}	VCC DC supply current	$V_S = 16V$, $V_{CC} = 5.3V$ CSN = V_{CC} active mode		1	3	mA
	VCC quiescent supply current	$V_S = 16V$, $V_{CC} = 5.3V$ CSN = V_{CC} standby mode OUT1 - OUT11 floating		25	50	μA
$I_S + I_{CC}$	sum quiescent supply current	$V_S = 16V$, $V_{CC} = 5.3V$ CSN = V_{CC} standby mode OUT1 - OUT11 floating		31	75	μA
Over- and undervoltage detection:						
$V_{SUV\ ON}$	VS UV-threshold voltage	V_S increasing	5.9		7.2	V
$V_{SUV\ OFF}$	VS UV-threshold voltage	V_S decreasing	5.5		6.5	V
$V_{SUV\ hyst}$	VS UV-hysteresis	$V_{SUV\ ON} - V_{SUV\ OFF}$		0.5		V
$V_{SOV\ OFF}$	VS OV-threshold voltage	V_S increasing	18		24.5	V

Table 7. ELECTRICAL CHARACTERISTICS (continued)

($V_S = 8$ to $16V$, $V_{CC} = 4.5$ to $5.3V$, $T_j = -40$ to $150\text{ }^\circ\text{C}$, unless otherwise specified. The voltages are referred to GND and currents are assumed positive, when the current flows into the pin)

Symbol	Parameter	Test Condition	Min.	Typ.	Max.	Unit
$V_{SOV\ ON}$	VS OV-threshold voltage	V_S decreasing	17.5		22	V
$V_{SOV\ hyst}$	VS OV-hysteresis	$V_{SOV\ OFF} - V_{SOV\ ON}$		1		V
$V_{POR\ OFF}$	power-on-reset threshold	V_{CC} increasing			4.4	V
$V_{POR\ ON}$	power-on-reset threshold	V_{CC} decreasing	3.1			V
$V_{POR\ hyst}$	power-on-reset hysteresis	$V_{POR\ OFF} - V_{POR\ ON}$		0.3		V
Current Monitor Output						
V_{CM}	functional voltage range	$V_{CC} = 5V$	0		4	V
$I_{CM,r}$	current monitor output ratio: $I_{CM} / I_{OUT1,4,5,6,11}$	$0V \leq V_{CM} \leq 4V$, $V_{CC}=5V$		$\frac{1}{10.000}$		-
$I_{CM\ acc}$	current monitor accuracy	$0V \leq V_{CM} \leq 3.8V$, $V_{CC} = 5V$, $I_{Out,min} = 500mA$, $I_{Out4,5,11,max} = 5.9A$ $I_{Out1,6,max} = 2.9A$ (FS = full scale=600 μ A)		4% + 1%FS	8% + 2%FS	-
Change Pump Output:						
V_{CP}	charge pump output voltage	$V_S=8V$, $I_{CP}=-60\mu A$	6		13	V
		$V_S=10V$, $I_{CP}=-80\mu A$	8		13	V
		$V_S \geq 12V$, $I_{CP}=-100\mu A$	10		13	V
I_{CP}	charge pump output current	$V_{CP} = V_S+10V$, $V_S=13.5V$	95	150	300	μA
Outputs: OUT1 - OUT2						
$r_{ON\ OUT1}, r_{ON\ OUT6}$	on-resistance to supply or GND	$V_S = 13.5V$, $T_j = 25\text{ }^\circ\text{C}$, $I_{OUT1,6} = \pm 1.5A$		300	400	m Ω
		$V_S = 13.5V$, $T_j = 125\text{ }^\circ\text{C}$, $I_{OUT1,6} = \pm 1.5A$		450	600	m Ω
		$V_S = 8.0V$, $T_j = 25\text{ }^\circ\text{C}$, $I_{OUT1,6} = \pm 1.5A$		300	400	m Ω
$r_{ON\ OUT2}, r_{ON\ OUT3}$	on-resistance to supply or GND	$V_S = 13.5V$, $T_j = 25\text{ }^\circ\text{C}$, $I_{OUT2,3} = \pm 0.8A$		800	1100	m Ω
		$V_S = 13.5V$, $T_j = 125\text{ }^\circ\text{C}$, $I_{OUT2,3} = \pm 0.8A$		1250	1700	m Ω
		$V_S = 8.0V$, $T_j = 25\text{ }^\circ\text{C}$, $I_{OUT2,3} = \pm 0.8A$		800	1100	m Ω
$r_{ON\ OUT4}, r_{ON\ OUT5}$	on-resistance to supply or GND	$V_S = 13.5V$, $T_j = 25\text{ }^\circ\text{C}$, $I_{OUT4,5} = \pm 3.0A$		150	200	m Ω
		$V_S = 13.5V$, $T_j = 125\text{ }^\circ\text{C}$, $I_{OUT4,5} = \pm 3.0A$		225	300	m Ω
		$V_S = 8.0V$, $T_j = 25\text{ }^\circ\text{C}$, $I_{OUT4,5} = \pm 3.0A$		150	200	m Ω

Table 7. ELECTRICAL CHARACTERISTICS (continued)

($V_S = 8$ to $16V$, $V_{CC} = 4.5$ to $5.3V$, $T_j = -40$ to $150\text{ }^\circ\text{C}$, unless otherwise specified. The voltages are referred to GND and currents are assumed positive, when the current flows into the pin)

Symbol	Parameter	Test Condition	Min.	Typ.	Max.	Unit
$r_{ON\ OUT7}, r_{ON\ OUT8}, r_{ON\ OUT9}, r_{ON\ OUT10}$	on-resistance to supply	$V_S = 13.5\text{ V}, T_j = 25\text{ }^\circ\text{C}, I_{OUT7,8,9,10} = -0.8\text{ A}$		800	1100	m Ω
		$V_S = 13.5\text{ V}, T_j = 125\text{ }^\circ\text{C}, I_{OUT7,8,9,10} = -0.8\text{ A}$		1250	1700	m Ω
		$V_S = 8.0\text{ V}, T_j = 25\text{ }^\circ\text{C}, I_{OUT7,8,9,10} = -0.8\text{ A}$		800	1100	m Ω
$r_{ON\ OUT11}$	on-resistance to supply	$V_S = 13.5\text{ V}, T_j = 25\text{ }^\circ\text{C}, I_{OUT11} = -3.0\text{ A}$		100	150	m Ω
		$V_S = 13.5\text{ V}, T_j = 125\text{ }^\circ\text{C}, I_{OUT11} = -3.0\text{ A}$		150	200	m Ω
		$V_S = 8.0\text{ V}, T_j = 25\text{ }^\circ\text{C}, I_{OUT11} = -3.0\text{ A}$		100	150	m Ω
$ I_{OUT1} , I_{OUT6} $	output current limitation to supply or GND	sink and source, $V_S = 13.5V$	3		5	A
$ I_{OUT2} , I_{OUT3} $	output current limitation to supply or GND	sink and source, $V_S = 13.5V$	1.5		2.5	A
$ I_{OUT4} , I_{OUT5} $	output current limitation to supply or GND	sink and source, $V_S = 13.5V$	6		10	A
$ I_{OUT7} , I_{OUT8} , I_{OUT9} , I_{OUT10} $	output current limitation to GND	source, $V_S = 13.5V$	1.5		2.5	A
$ I_{OUT11} $	output current limitation to GND	source, $V_S = 13.5V$	6		10	A
$t_{d\ ON\ H}$	output delay time, highside driver on	$V_S = 13.5\text{ V}$, corresponding lowside driver is not active	20	40	80	μs
$t_{d\ OFF\ H}$	output delay time, highside driver off	$V_S = 13.5\text{ V}$	50	150	300	μs
$t_{d\ ON\ L}$	output delay time, lowside driver on	$V_S = 13.5\text{ V}$, corresponding highside driver is not active	15	30	70	μs
$t_{d\ OFF\ L}$	output delay time, lowside driver off	$V_S = 13.5\text{ V}$	80	150	300	μs
$t_{D\ HL}$	cross current protection time, source to sink	$t_{d\ ON\ L} - t_{d\ OFF\ H}$,		200	400	μs
$t_{D\ LH}$	cross current protection time, sink to source	$t_{d\ ON\ H} - t_{d\ OFF\ L}$		200	400	μs
I_{QLH}	switched-off output current highside drivers of OUT1-11	$V_{OUT1-11} = 0V$, standby mode	0	-2	-5	μA
		$V_{OUT1-11} = 0V$, active mode	-40	-15	0	μA
I_{QLL}	switched-off output current lowside drivers of OUT1-6	$V_{OUT1-6} = V_S$, standby mode	0	80	120	μA
		$V_{OUT1-6} = V_S$, active mode	-40	-15	0	μA
I_{OLD1}	open load detection current of OUT1		5	30	80	mA

Table 7. ELECTRICAL CHARACTERISTICS (continued)

($V_S = 8$ to 16 V, $V_{CC} = 4.5$ to 5.3 V, $T_j = -40$ to 150 °C, unless otherwise specified. The voltages are referred to GND and currents are assumed positive, when the current flows into the pin)

Symbol	Parameter	Test Condition	Min.	Typ.	Max.	Unit
I_{OLD23}	open load detection current of OUT2, OUT3		15	40	60	mA
I_{OLD45}	open load detection current of OUT4 and OUT5		60	150	300	mA
I_{OLD6}	open load detection current of OUT6		30	70	150	mA
$I_{OLD78910}$	open load detection current of OUT7, OUT8, OUT9, OUT10		15	40	60	mA
I_{OLD11}	open load detection current of OUT11		30	150	300	mA
t_{dOL}	minimum duration of open load condition to set the status bit		500		3000	μ s
t_{ISC}	minimum duration of over-current condition to switch off the driver		10		100	μ s
dV_{OUT16}/dt	slew rate of OUT1,OUT6	$V_S = 13.5$ V $I_{load} = \pm 1.5$ A	0.1	0.2	0.4	V/ μ s
dV_{OUT23}/dt , $dV_{OUT78910}/dt$	slew rate of OUT2/3 and OUT7-OUT10	$V_S = 13.5$ V $I_{load} = -0.8$ A	0.09	0.2	0.4	V/ μ s
dV_{OUT45}/dt	slew rate of OUT4, OUT5	$V_S = 13.5$ V $I_{load} = \pm 3.0$ A	0.1	0.2	0.4	V/ μ s
dV_{OUT11}/dt	slew rate of OUT11	$V_S = 13.5$ V $I_{load} = 3.0$ A	0.1	0.2	0.4	V/ μ s

4 FUNCTIONAL DESCRIPTION OF THE SPI

4.1 Serial Peripheral Interface (SPI)

This device uses a standard SPI to communicate with a microcontroller. The SPI can be driven by a microcontroller with its SPI peripheral running in following mode: CPOL = 0 and CPHA = 0.

For this mode, input data is sampled by the low to high transition of the clock CLK, and output data is changed from the high to low transition of CLK.

This device is not limited to microcontroller with a build-in SPI. Only three CMOS-compatible output pins and one input pin will be needed to communicate with the device. A fault condition can be detected by setting CSN to low. If CSN = 0, the DO-pin will reflect the status bit 0 (fault condition) of the device which is a logical-or of all bits in the status registers 0 and 1. The microcontroller can poll the status of the device without the need of a full SPI-communication cycle.

Note: In contrast to the SPI-standard the least significant bit (LSB) will be transferred first (see FIGURE 6).

4.2 Chip Select Not (CSN)

The input pin is used to select the serial interface of this device. When CSN is high, the output pin (DO) will be in high impedance state. A low signal will activate the output driver and a serial communication can be started. The state when CSN is going low until the rising edge of CSN will be called a communication frame. If the CSN-input pin is driven above 7.5V, the L9950 will go into a test mode. In the test mode the DO will go from tri-state to active mode.

4.3 Serial Data In (DI)

The input pin is used to transfer data serial into the device. The data applied to the DI will be sampled at the rising edge of the CLK signal and shifted into an internal 24 bit shift register. At the rising edge of the CSN signal the contents of the shift register will be transferred to Data Input Register. The writing to the selected Data Input Register is only enabled if exactly 24 bits are transmitted within one communication frame (i.e. CSN low). If more or less clock pulses are counted within one frame the complete frame will be ignored. This safety function is implemented to avoid an activation of the output stages by a wrong communication frame.

Note: Due to this safety functionality a daisy chaining of SPI is not possible. Instead, a parallel operation of the SPI bus by controlling the CSN signal of the connected ICs is recommended.

4.4 Serial Data Out (DO)

The data output driver is activated by a logical low level at the CSN input and will go from high impedance to a low or high level depending on the status bit 0 (fault condition). The first rising edge of the CLK input after a high to low transition of the CSN pin will transfer the content of the selected status register into the data out shift register. Each subsequent falling edge of the CLK will shift the next bit out.

4.5 Serial Clock (CLK)

The CLK input is used to synchronize the input and output serial bit streams. The data input (DI) is sampled at the rising edge of the CLK and the data output (DO) will change with the falling edge of the CLK signal.

4.6 Input Data Register

The device has two input registers. The first bit (bit 0) at the DI-input is used to select one of the two Input Registers. All bits are first shifted into an input shift register. After the rising edge of CSN the contents of the input shift register will be written to the selected Input Data Register only if a frame of exact 24 data bits are detected. Depending on bit 0 the contents of the selected status register will be transferred to DO during the current communication frame. Bit 1-17 controls the behaviour of the corresponding driver.

If bit 23 is zero, the device will go into the standby-mode. The bits 18 and 19 are used to control the current monitor multiplexer. Bit 22 is used to reset all status bits in both status registers. The bits in the status registers will be cleared after the current communication frame (rising edge of CSN).

4.7 Status Register

This devices uses two status registers to store and to monitor the state of the device. Bit 0 is used as a fault bit and is a logical-NOR combination of bits 1-22 in both status registers. The state of this bit can be polled by the microcontroller without the need of a full SPI-communication cycle (see FIGURE 11). If one of the over-current bits is set, the corresponding driver will be disabled. If the over-current recovery bit of the output is not set the microcontroller has to clear the over-current bit to enable the driver. If the thermal shutdown bit is set, all drivers will go into a high impedance state. Again the microcontroller has to clear the bit to enable the drivers.

4.8 Test Mode

The Test Mode can be entered by rising the CSN input to a voltage higher than 7.0V. In the test mode the inputs CLK, DI, PWM1/2 and the internal 2MHz CLK can be multiplexed to data output DO for testing purpose. Furthermore the over-current thresholds are reduced by a factor of 4 to allow EWS testing at lower current. For EWS testing a special test pad is available to measure the internal bandgap voltage, the TW and TSD thresholds.

The internal logic prevents that the Hi-Side and Lo-Side driver of the same half-bridge can be switched-on at the same time. In the testmode this combination is used to multiplex the desired signals according to following table 8:

Table 8.

LS1	HS1	LS2	HS2	LS3	HS3	DO	LS3	HS3	LS4	HS4	LS5	HS5	Test Pad
! (both HI)	! (both HI)	! (both HI)	! (both HI)	! (both HI)	! (both HI)	NoError	! (both HI)	! (both HI)	! (both HI)	! (both HI)	! (both HI)	! (both HI)	5 μ A Iref
both HI	both HI	! (both HI)	! (both HI)	! (both HI)	! (both HI)	DI	both HI	! (both HI)	! (both HI)	! (both HI)	! (both HI)	! (both HI)	Tsens1
! (both HI)	both HI	both HI	both HI	! (both HI)	! (both HI)	CLK	! (both HI)	both HI	both HI	both HI	! (both HI)	! (both HI)	Tsens2
both HI	both HI	both HI	both HI	! (both HI)	! (both HI)	INT_CLK	both HI	both HI	both HI	both HI	! (both HI)	! (both HI)	Tsens3
! (both HI)	! (both HI)	both HI	both HI	both HI	both HI	PWM1	! (both HI)	! (both HI)	both HI	both HI	both HI	both HI	Tsens4
both HI	! (both HI)	both HI	both HI	both HI	both HI	PWM2	both HI	! (both HI)	both HI	both HI	both HI	both HI	Tsens5
! (both HI)	both HI	both HI	both HI	both HI	both HI		! (both HI)	both HI	both HI	both HI	both HI	both HI	Tsens6
both HI	both HI	both HI	both HI	both HI	both HI		both HI	both HI	both HI	both HI	both HI	both HI	Vbandgap

Table 9. SPI - Input Data and Status Register

Bit	Input Register 0 (write)			Status Register 0 (read)		
	Name	Comment		Name	Comment	
23	Enable Bit	If Enable Bit is set the device will be switched in active mode. If Enable Bit is cleared device go into standby mode and all bits are cleared. After power-on reset device starts in standby mode.		Always 1	A broken VCC-or SPI-connection of the L9950 can be detected by the microcontroller, because all 24 bits low or high is not a valid frame.	
22	Reset Bit	If Reset Bit is set both status registers will be cleared after rising edge of CSN input.		V _S overvoltage	In case of an overvoltage or undervoltage event the corresponding bit is set and the outputs are deactivated. If VS voltage recovers to normal operating conditions outputs are reactivated automatically (if Bit 20 of status register 0 is not set).	
21	OC Recovery Duty Cycle	This bit defines in combination with the over-current recovery bit (Input Register 1) the duty cycle in over-current condition of an activated driver.		V _S undervoltage		
	0: 12% 1: 25%					
20	Overvoltage/ Under-voltage recovery disable	If this bit is set the microcontroller has to clear the status register after undervoltage/overvoltage event to enable the outputs.		Thermal shutdown	In case of an thermal shutdown all outputs are switched off. The microcontroller has to clear the TSD bit by setting the Reset Bit to reactivate the outputs.	
19		Depending on combination of bit 18 and 19 the current image (1/10.000) of the selected HS-output will be multi-plexed to the CM output:		Temperature warning	This bit is for information purpose only. It can be used for a thermal management by the microcontroller to avoid a thermal shutdown.	
18	Current Monitor Select Bits	Bit 19	Bit 18	Output	Not Ready Bit	After switching the device from standby mode to active mode an internal timer is started to allow chargepump to settle before the outputs can be activated. This bit is cleared automatically after start up time has finished. Since this bit is controlled by internal clock it can be used for synchronizing testing events (e.g. measuring filter times).
		0	0	OUT11		
		1	0	OUT1/OUT6		
		0	1	OUT5		
		1	1	OUT4		
HS-driver of OUT1 is only selected if HS-driver OUT1 is switched on and HS-driver OUT6 is not activated.						

Table 9. SPI - Input Data and Status Register (continued)

Bit	Input Register 0 (write)		Status Register 0 (read)	
	Name	Comment	Name	Comment
17	OUT11 – HS on/off	If a bit is set the selected output driver is switched on. If the corresponding PWM enable bit is set (Input Register 1) the driver is only activated if PWM1 (PWM2) input signal is high. The outputs of OUT1-OUT6 are half bridges. If the bits of HS- and LS-driver of the same half bridge are set, the internal logic prevents that both drivers of this output stage can be switched on simultaneously in order to avoid a high internal current from VS to GND. In test mode (CSN>7.5V) this bit combinations are used to multiplex internal signals to the DO-output.	OUT11 – HS over-current	In case of an over-current event the corresponding status bit is set and the output driver is disabled. If the over-current Recovery Enable bit is set (Input Register 1) the output will be automatically reactivated after a delay time resulting in a PWM modulated current with a programmable duty cycle (Bit 21). If the over-current recovery bit is not set the microcontroller has to clear the over-current bit (Reset Bit) to reactivate the output driver.
16	OUT10 – HS on/off		OUT10 – HS over-current	
15	OUT9 – HS on/off		OUT9 – HS over-current	
14	OUT8 – HS on/off		OUT8 – HS over-current	
13	OUT7 – HS on/off		OUT7 – HS over-current	
12	OUT6 – HS on/off		OUT6 – HS over-current	
11	OUT6 – LS on/off		OUT6 – LS over-current	
10	OUT5 – HS on/off		OUT5 – HS over-current	
9	OUT5 – LS on/off		OUT5 – LS over-current	
8	OUT4 – HS on/off		OUT4 – HS over-current	
7	OUT4 – LS on/off		OUT4 – LS over-current	
6	OUT3 – HS on/off		OUT3 – HS over-current	
5	OUT3 – LS on/off		OUT3 – LS over-current	
4	OUT2 – HS on/off		OUT2 – HS over-current	
3	OUT2 – LS on/off		OUT2 – LS over-current	
2	OUT1 – HS on/off		OUT1 – HS over-current	
1	OUT1 – LS on/off		OUT1 – LS over-current	
0	0		No error Bit	A logical NOR-combination of all bits 1 to 22 in both status registers.

Table 9. SPI - Input Data and Status Register (continued)

Bit	Input Register 1 (write)		Status Register 1 (read)	
	Name	Comment	Name	Comment
23	Enable Bit	If Enable Bit is set the device will be switched in active mode. If Enable Bit is cleared device go into standby mode and all bits are cleared. After power-on reset device starts in standby mode.	Always 1	A broken VCC-or SPI-connection of the L9950 can be detected by the microcontroller, because all 24 bits low or high is not a valid frame.

Table 9. SPI - Input Data and Status Register (continued)

Bit	Input Register 1 (write)		Status Register 1 (read)	
	Name	Comment	Name	Comment
22	OUT11 OC Recovery Enable	In case of an over-current event the over-current status bit (Status Register 0) is set and the output is switched off. If the over-current Recovery Enable bit is set the output will be automatically reactivated after a delay time resulting in a PWM modulated current with a programmable duty cycle (Bit 21 of Input Data Register 0). Depending on occurrence of Overcurrent Event and internal clock phase it is possible that one recovery cycle is executed even if this bit is set to zero.	VS overvoltage	In case of an overvoltage or undervoltage event the corresponding bit is set and the outputs are deactivated. If VS voltage recovers to normal operating conditions outputs are reactivated automatically.
21	OUT10 OC Recovery Enable		VS undervoltage	
20	OUT9 OC Recovery Enable		Thermal shutdown	In case of a thermal shutdown all outputs are switched off. The microcontroller has to clear the TSD bit by setting the Reset Bit to reactivate the outputs.
19	OUT8 OC Recovery Enable		Temperature warning	This bit is for information purpose only. It can be used for a thermal management by the microcontroller to avoid a thermal shutdown.
18	OUT7 OC Recovery Enable		Not Ready Bit	After switching the device from standby mode to active mode an internal timer is started to allow chargepump to settle before the outputs can be activated. This bit is cleared automatically after start up time has finished. Since this bit is controlled by internal clock it can be used for synchronizing testing events(e.g. measuring filter times).

Table 9. SPI - Input Data and Status Register (continued)

Bit	Input Register 1 (write)		Status Register 1 (read)	
	Name	Comment	Name	Comment
17	OUT6 OC Recovery Enable	After 50ms the bit can be cleared. If over-current condition still exists, a wrong load can be assumed.	OUT11 – HS open load	The open load detection monitors the load current in each activated output stage. If the load current is below the open load detection threshold for at least 1 ms (t_{dOL}) the corresponding open load bit is set. Due to mechanical/electrical inertia of typical loads a short activation of the outputs (e.g. 3ms) can be used to test the open load status without changing the mechanical/ electrical state of the loads.
16	OUT5 OC Recovery Enable		OUT10 – HS open load	
15	OUT4 OC Recovery Enable		OUT9 – HS open load	
14	OUT3 OC Recovery Enable		OUT8 – HS open load	
13	OUT2 OC Recovery Enable		OUT7 – HS open load	
12	OUT1 OC Recovery Enable		OUT6 – HS open load	
11	OUT11 PWM1 Enable	If the PWM1/2 Enable Bit is set and the output is enabled (Input Register 0) the output is switched on if PWM1/2 input is high and switched off if PWM1/2 input is low. OUT9 and OUT10 is controlled by PWM2 input all other outputs are controlled by PWM1 input.	OUT6 – LS open load	
10	OUT10 PWM2 Enable		OUT5 – HS open load	
9	OUT9 PWM2 Enable		OUT5 – LS open load	
8	OUT8 PWM1 Enable		OUT4 – HS open load	
7	OUT7 PWM1 Enable		OUT4 – LS open load	
6	OUT6 PWM1 Enable		OUT3 – HS open load	
5	OUT4 PWM1 Enable		OUT3 – LS open load	
4	OUT4 PWM1 Enable		OUT2 –HS open load	
3	OUT3 PWM1 Enable		OUT2– LS open load	
2	OUT4 PWM1 Enable		OUT1 – HS open load	
1	OUT4 PWM1 Enable	OUT1 – LS open load		
0	1		No Error bit	A logical NOR-combination of all bits 1 to 22 in both status registers.

Table 10. SPI - ELECTRICAL CHARACTERISTICS

($V_S = 8$ to $16V$, $V_{CC} = 4.5$ to $5.3V$, $T_j = -40$ to 150 °C, unless otherwise specified. The voltages are referred to GND and currents are assumed positive, when the current flows into the pin).

Symbol	Parameter	Test Condition	Min.	Typ.	Max.	Unit
Delay time from standby to active mode						
t_{set}	delay time	Switching from standby to active mode. Time until output drivers are enabled after CSN going to high.		160	300	μs
Inputs: CSN, CLK, PWM1/2 and DI						
V_{inL}	input low level	$V_{CC} = 5V$	1.5	2.0		V
V_{inH}	input high level	$V_{CC} = 5V$		3.0	3.5	V
V_{inHyst}	input hysteresis	$V_{CC} = 5V$	0.5			V
$I_{CSN\ in}$	pull up current at input CSN	$V_{CSN} = 3.5V$ $V_{CC} = 5V$	-40	-20	-8	μA
$I_{CLK\ in}$	pull down current at input CLK	$V_{CLK} = 1.5V$	10	25	50	μA
$I_{DI\ in}$	pull down current at input DI	$V_{DI} = 1.5V$	10	25	50	μA
$I_{PWM1\ in}$	pull down current at input PWM1	$V_{PWM} = 1.5V$	10	25	50	μA
C_{in}^1	input capacitance at input CSN, CLK, DI and PWM1/2	$V_{CC} = 0$ to $5.3V$		10	15	pF
DI timing (see figure 5 and figure 7)²						
t_{CLK}	clock period	$V_{CC} = 5V$	1000			ns
t_{CLKH}	clock high time	$V_{CC} = 5V$	400			ns
t_{CLKL}	clock low time	$V_{CC} = 5V$	400			ns
$t_{set\ CSN}$	CSN setup time, CSN low before rising edge of CLK	$V_{CC} = 5V$	400			ns
$t_{set\ CLK}$	CLK setup time, CLK high before rising edge of CSN	$V_{CC} = 5V$	400			ns
$t_{set\ DI}$	DI setup time	$V_{CC} = 5V$	200			ns
$t_{hold\ time}$	DI hold time	$V_{CC} = 5V$	200			ns
$t_{r\ in}$	rise time of input signal DI, CLK, CSN	$V_{CC} = 5V$			100	ns
$t_{f\ in}$	fall time of input signal DI, CLK, CSN	$V_{CC} = 5V$			100	ns

Note: 1. Value of input capacity is not measured in production test. Parameter guaranteed by design.

2. DI timing parameters tested in production by a passed/failed test:

$T_j = -40^\circ C / +25^\circ C$: SPI communication @2MHZ
 $T_j = +125^\circ C$: SPI communication @1.25MHZ

Table 10. SPI - ELECTRICAL CHARACTERISTICS (continued)

Symbol	Parameter	Test Condition	Min.	Typ.	Max.	Unit
DO						
V _{DOL}	output low level	V _{CC} = 5 V, I _D = -2mA		0.2	0.4	V
V _{DOH}	output high level	V _{CC} = 5 V, I _D = 2 mA	V _{CC} -0.4	V _{CC} -0.2		V
I _{DOLK}	tristate leakage current	V _{CSN} = V _{CC} , 0V < V _{DO} < V _{CC}	-10		10	μA
C _{DO} ³	tristate input capacitance	V _{CSN} = V _{CC} , 0V < V _{CC} < 5.3V		10	15	pF
DO timing (see FIGURE 6 and FIGURE 7)						
t _{r DO}	DO rise time	C _L = 100 pF, I _{load} = -1mA		80	140	ns
t _{f DO}	DO fall time	C _L = 100 pF, I _{load} = 1mA		50	100	ns
t _{en DO tri L}	DO enable time from tristate to low level	C _L = 100 pF, I _{load} = 1mA pull-up load to V _{CC}		100	250	ns
t _{dis DO L tri}	DO disable time from low level to tristate	C _L = 100 pF, I _{load} = 4 mA pull-up load to V _{CC}		380	450	ns
t _{en DO tri H}	DO enable time from tristate to high level	C _L = 100 pF, I _{load} = -1mA pull-down load to GND		100	250	ns
t _{dis DO H tri}	DO disable time from high level to tristate	C _L = 100 pF, I _{load} = -4mA pull-down load to GND		380	450	ns
t _{d DO}	DO delay time	V _{DO} < 0.3 V _{CC} , V _{DO} > 0.7 V _{CC} , C _L = 100pF		50	250	ns
CSN timing (see FIGURE 8)						
t _{CSN_HI, stb}	Minimum CSN HI time, switching from standby mode	Transfer of SPI-command to Input Register		20	50	μs
t _{CSN_HI, min}	Maximum CSN HI time, active mode	Transfer of SPI-command to Input Register		2	4	μs

3. Value of input capacity is not measured in production test. Parameter guaranteed by design

Figure 6. SPI - TRANSFER TIMING DIAGRAM

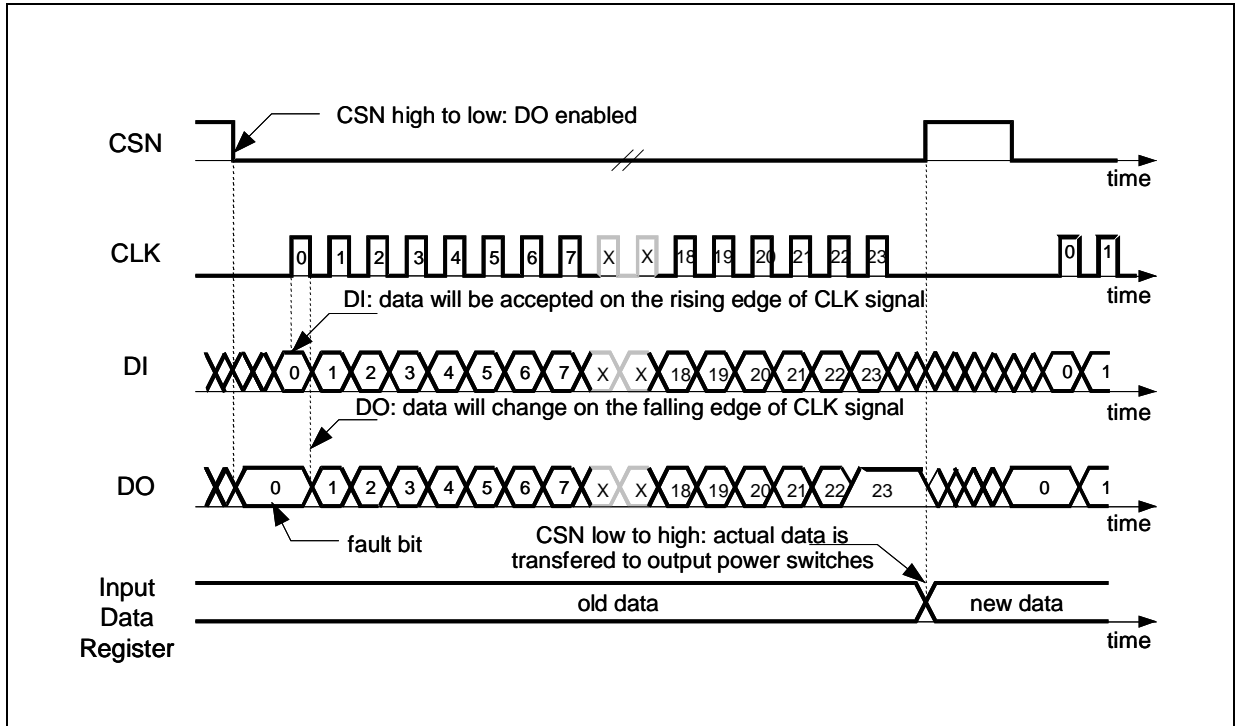

Figure 7. SPI - INPUT TIMING

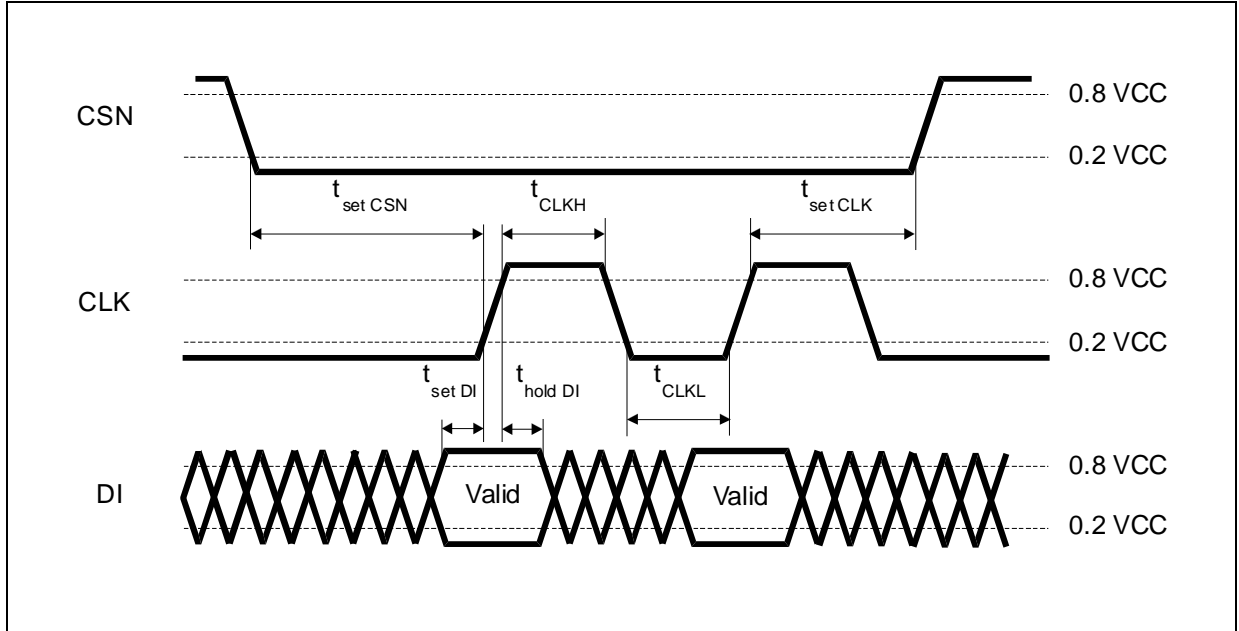

Figure 8. SPI - DO VALID DATA DELAY TIME AND VALID TIME

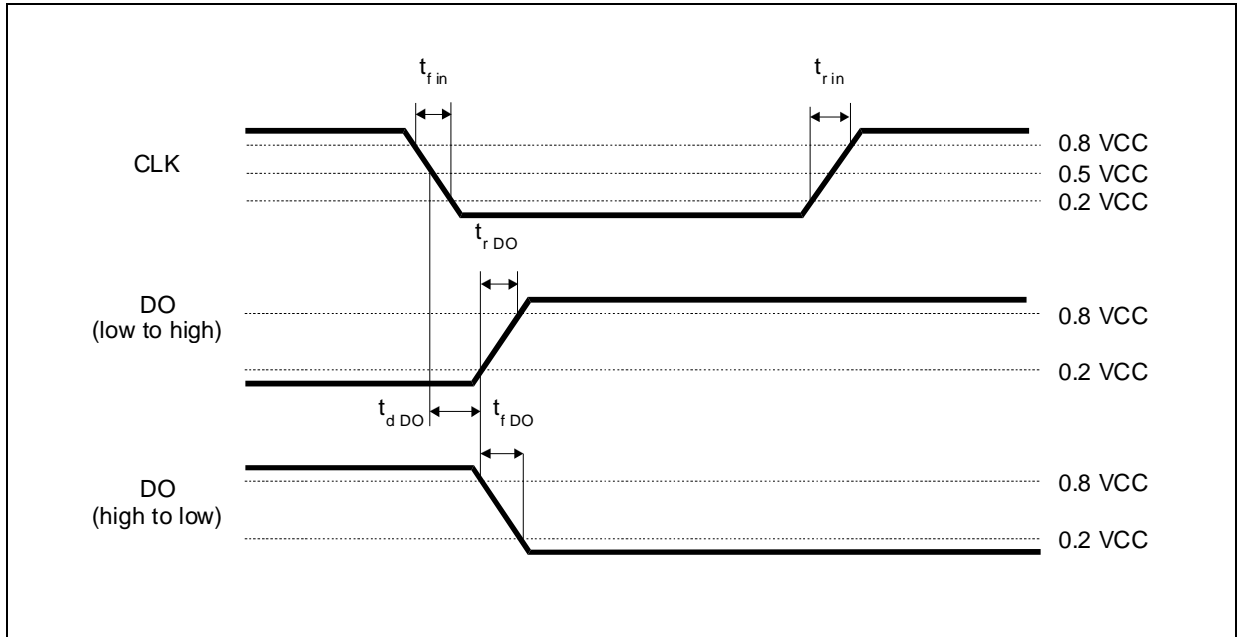

Figure 9. SPI - DO ENABLE AND DISABLE TIME

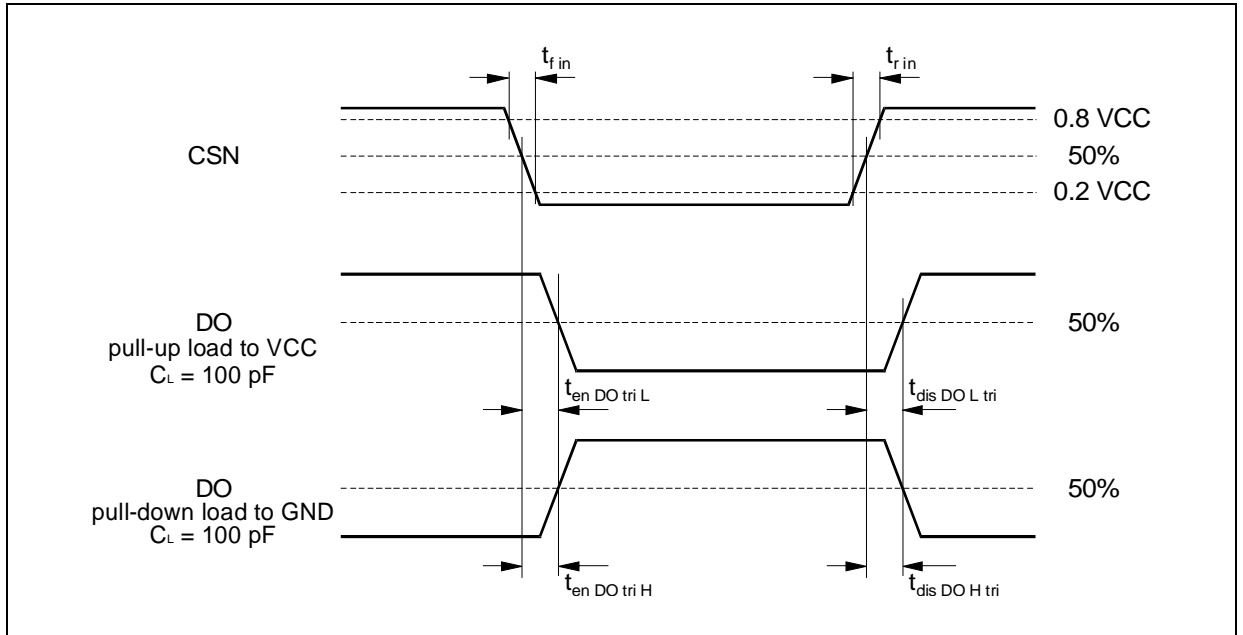

Figure 10. SPI - DRIVER TURN ON/OFF TIMING, MINIMUM CSN HI TIME

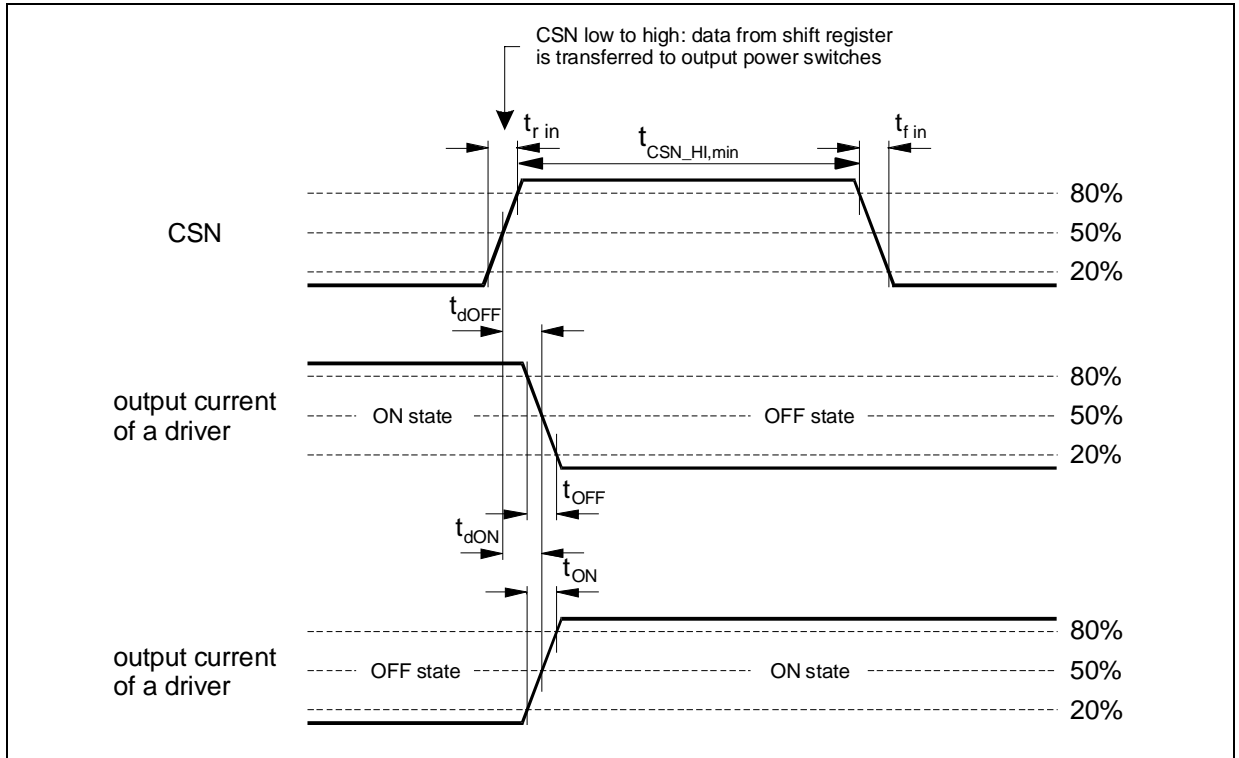

Figure 11. SPI - TIMING OF STATUS BIT 0 (FAULT CONDITION)

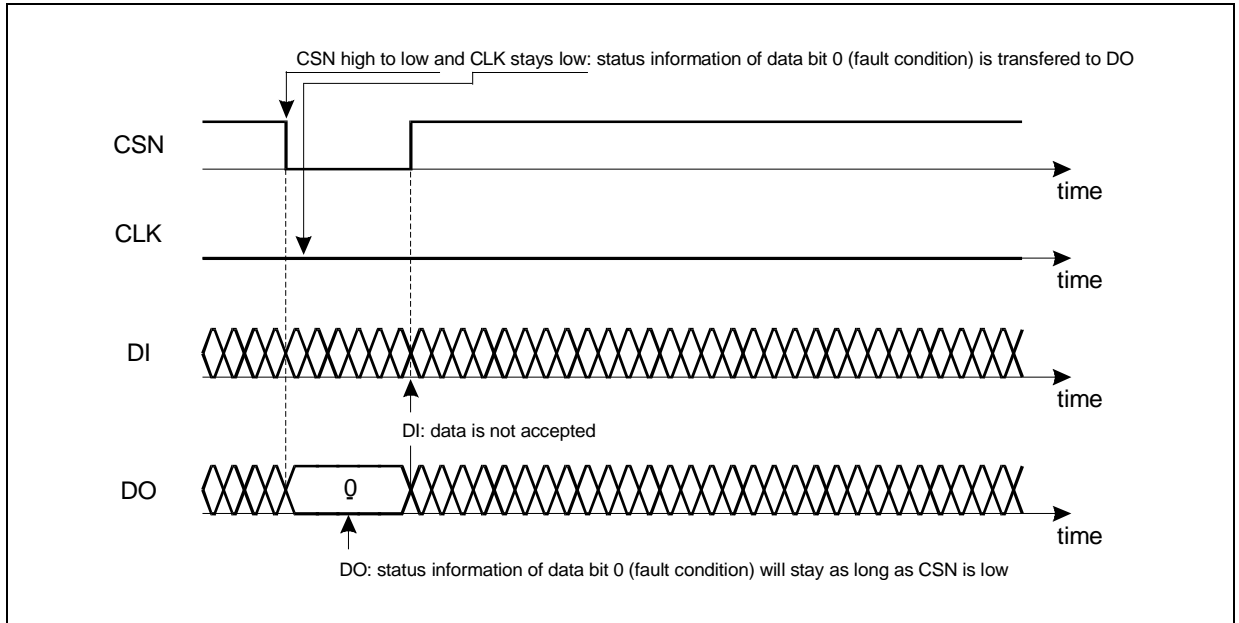
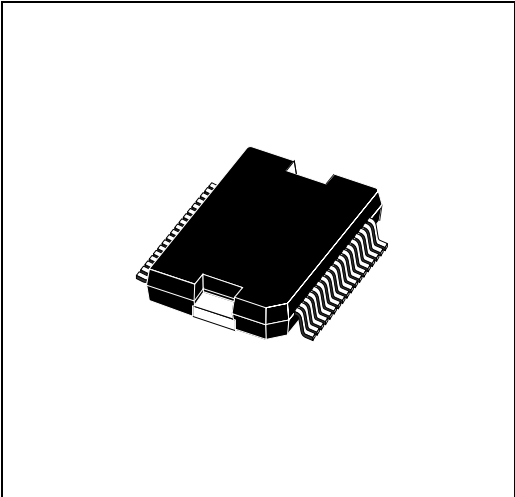

Figure 12. PowerSO36 Mechanical Data & Package Dimensions

DIM.	mm			inch		
	MIN.	TYP.	MAX.	MIN.	TYP.	MAX.
A	3.25		3.5	0.128		0.138
A2			3.3			0.13
A4	0.8		1	0.031		0.039
A5		0.2			0.008	
a1	0		0.075	0		0.003
b	0.22		0.38	0.008		0.015
c	0.23		0.32	0.009		0.012
D	15.8		16	0.622		0.630
D1	9.4		9.8	0.37		0.38
D2		1			0.039	
E	13.9		14.5	0.547		0.57
E1	10.9		11.1	0.429		0.437
E2			2.9			0.114
E3	5.8		6.2	0.228		0.244
E4	2.9		3.2	0.114		1.259
e		0.65			0.026	
e3		11.05			0.435	
G	0		0.075	0		0.003
H	15.5		15.9	0.61		0.625
h			1.1			0.043
L	0.8		1.1	0.031		0.043
N	10° (max)					
s	8° (max)					

Note: "D and E1" do not include mold flash or protrusions.
 - Mold flash or protrusions shall not exceed 0.15mm (0.006")
 - Critical dimensions are "a3", "E" and "G".

OUTLINE AND MECHANICAL DATA



PowerSO36

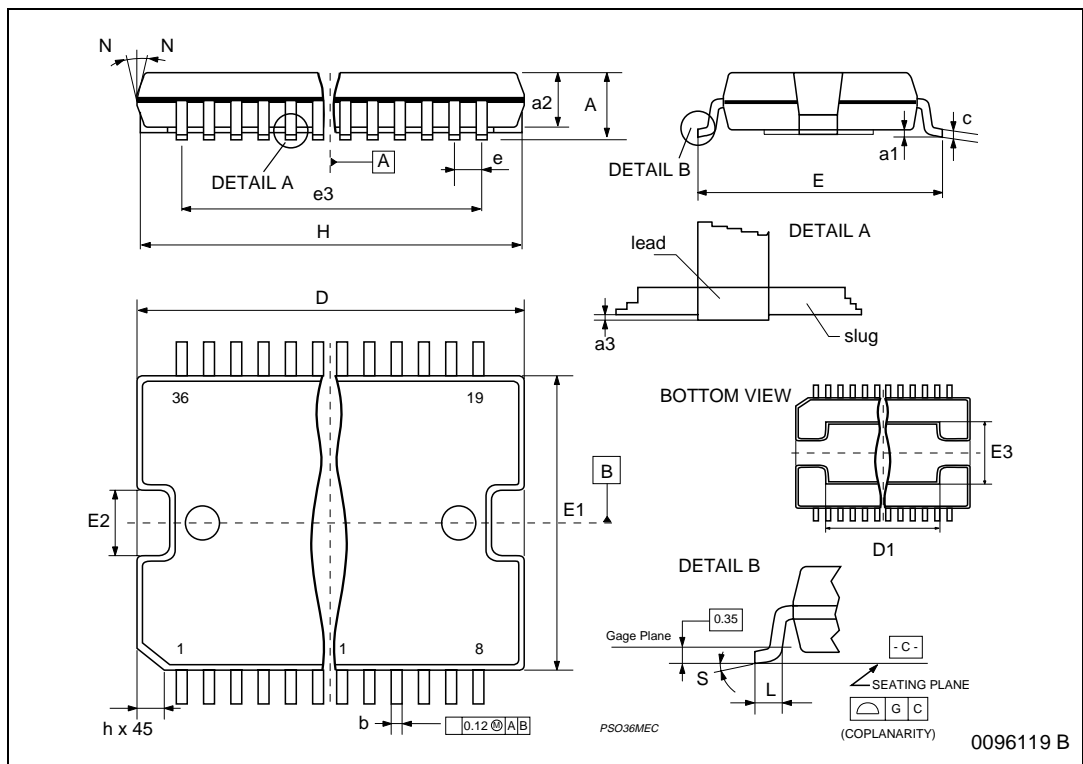

Table 11. Revision History

Date	Revision	Description of Changes
April 2004	1	First Issue
June 2004	2	Changed Maturity from Product Preview to Final. Changed values in the Table 4 ESD Protection.
July 2004	3	Small Change

Information furnished is believed to be accurate and reliable. However, STMicroelectronics assumes no responsibility for the consequences of use of such information nor for any infringement of patents or other rights of third parties which may result from its use. No license is granted by implication or otherwise under any patent or patent rights of STMicroelectronics. Specifications mentioned in this publication are subject to change without notice. This publication supersedes and replaces all information previously supplied. STMicroelectronics products are not authorized for use as critical components in life support devices or systems without express written approval of STMicroelectronics.

The ST logo is a registered trademark of STMicroelectronics.
All other names are the property of their respective owners

© 2004 STMicroelectronics - All rights reserved

STMicroelectronics GROUP OF COMPANIES

Australia - Belgium - Brazil - Canada - China - Czech Republic - Finland - France - Germany - Hong Kong - India - Israel - Italy - Japan -
Malaysia - Malta - Morocco - Singapore - Spain - Sweden - Switzerland - United Kingdom - United States

www.st.com