

**FEATURES**

- **2-Bit Bidirectional Translator for SDA and SCL Lines in Mixed-Mode I<sup>2</sup>C Applications**
- **I<sup>2</sup>C and SMBus Compatible**
- **Less Than 1.5-ns Maximum Propagation Delay to Accommodate Standard-Mode and Fast-Mode I<sup>2</sup>C Devices and Multiple Masters**
- **Allows Voltage-Level Translator Between**
  - 1.2-V  $V_{REF1}$  and 2.5-V, 3.3-V, or 5-V  $V_{REF2}$
  - 1.8-V  $V_{REF1}$  and 3.3-V or 5-V  $V_{REF2}$
  - 2.5-V  $V_{REF1}$  and 5-V  $V_{REF2}$
  - 3.3-V  $V_{REF1}$  and 5-V  $V_{REF2}$
- **Provides Bidirectional Voltage Translation With No Direction Pin**
- **Low 3.5-Ω ON-State Connection Between Input and Output Ports Provides Less Signal Distortion**
- **Open-Drain I<sup>2</sup>C I/O Ports (SCL1, SDA1, SCL2, and SDA2)**
- **5-V Tolerant I<sup>2</sup>C I/O Ports to Support Mixed-Mode Signal Operation**
- **High-Impedance SCL1, SDA1, SCL2, and SDA2 Pins for EN = Low**
- **Lock-Up-Free Operation for Isolation When EN = Low**
- **Flow-Through Pinout for Ease of Printed Circuit Board Trace Routing**
- **Latch-Up Performance Exceeds 100 mA Per JESD 78, Class II**
- **ESD Protection Exceeds JESD 22**
  - 2000-V Human-Body Model (A114-A)
  - 200-V Machine Model (A115-A)
  - 1000-V Charged-Device Model (C101)

**DCT OR DCU PACKAGE  
(TOP VIEW)**

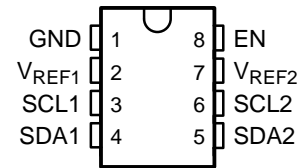

PIN	SYMBOL	FUNCTION
1	GND	Ground, 0 V
2	$V_{REF1}$	Low-voltage-side reference supply voltage for SCL1 and SDA1
3	SCL1	Serial clock, low-voltage side. Connect to $V_{REF1}$ through a pullup resistor.
4	SDA1	Serial data, low-voltage side. Connect to $V_{REF1}$ through a pullup resistor.
5	SDA2	Serial data, high-voltage side. Connect to $V_{REF2}$ through a pullup resistor.
6	SCL2	Serial clock, high-voltage side. Connect to $V_{REF2}$ through a pullup resistor.
7	$V_{REF2}$	High-voltage-side reference supply voltage for SCL2 and SDA2
8	EN	Switch enable input. Connected to $V_{REF2}$ and pulled up through a high resistor.



Please be aware that an important notice concerning availability, standard warranty, and use in critical applications of Texas Instruments semiconductor products and disclaimers thereto appears at the end of this data sheet.

## DESCRIPTION/ORDERING INFORMATION

This dual bidirectional I<sup>2</sup>C and SMBus voltage-level translator, with an enable (EN) input, is operational from 1.2-V to 3.3-V V<sub>REF1</sub> and 2.5-V to 5.5-V V<sub>REF2</sub>.

The PCA9306 allows bidirectional voltage translations between 1.2 V and 5 V, without the use of a direction pin. The low ON-state resistance (r<sub>on</sub>) of the switch allows connections to be made with minimal propagation delay. When EN is high, the translator switch is ON, and the SCL1 and SDA1 I/O are connected to the SCL2 and SDA2 I/O, respectively, allowing bidirectional data flow between ports. When EN is low, the translator switch is off, and a high-impedance state exists between ports.

In I<sup>2</sup>C applications, the bus capacitance limit of 400 pF restricts the number of devices and bus length. Using the PCA9306 enables the system designer to isolate two halves of a bus; thus, more I<sup>2</sup>C devices or longer trace length can be accommodated.

The PCA9306 also can be used to run two buses, one at 400-kHz operating frequency and the other at 100-kHz operating frequency. If the two buses are operating at different frequencies, the 100-kHz bus must be isolated when the 400-kHz operation of the other bus is required. If the master is running at 400 kHz, the maximum system operating frequency may be less than 400 kHz because of the delays added by the repeater.

As with the standard I<sup>2</sup>C system, pullup resistors are required to provide the logic high levels on the translator's bus. The PCA9306 has a standard open-collector configuration of the I<sup>2</sup>C bus. The size of these pullup resistors depends on the system, but each side of the repeater must have a pullup resistor. The device is designed to work with standard-mode and fast-mode I<sup>2</sup>C devices, in addition to SMBus devices. Standard-mode I<sup>2</sup>C devices only specify 3 mA in a generic I<sup>2</sup>C system where standard-mode devices and multiple masters are possible. Under certain conditions, high termination currents can be used.

When the SDA1 or SDA2 port is low, the clamp is in the ON state, and a low resistance connection exists between the SDA1 and SDA2 ports. Assuming the higher voltage is on the SDA2 port when the SDA2 port is high, the voltage on the SDA1 port is limited to the voltage set by V<sub>REF1</sub>. When the SDA1 port is high, the SDA2 port is pulled to the drain pullup supply voltage (V<sub>DPU</sub>) by the pullup resistors. This functionality allows a seamless translation between higher and lower voltages selected by the user, without the need for directional control. The SCL1/SCL2 channel also functions as the SDA1/SDA2 channel.

All channels have the same electrical characteristics, and there is minimal deviation from one output to another in voltage or propagation delay. This is a benefit over discrete transistor voltage translation solutions, since the fabrication of the switch is symmetrical. The translator provides excellent ESD protection to lower-voltage devices and at the same time protects less ESD-resistant devices.

## ORDERING INFORMATION

T <sub>A</sub>	PACKAGE (1)		ORDERABLE PART NUMBER	TOP-SIDE MARKING (2)
-40°C to 85°C	SSOP – DCT	Reel of 3000	PCA9306DCTR	7BD_ _ _
		Reel of 250	PCA9306DC TT	
	VSSOP – DCU	Reel of 3000	PCA9306DCUR	7BD_
		Reel of 250	PCA9306DCUT	

(1) Package drawings, standard packing quantities, thermal data, symbolization, and PCB design guidelines are available at [www.ti.com/sc/package](http://www.ti.com/sc/package).

(2) DCT: The actual top-side marking has three additional characters that designate the year, month, and assembly/test site.  
 DCU: The actual top-side marking has one additional character that designates the assembly/test site.

**FUNCTION TABLE**

INPUT EN <sup>(1)</sup>	TRANSLATOR FUNCTION
H	SCL1 = SCL2, SDA1 = SDA2
L	Disconnect

(1) EN is controlled by the  $V_{REF2}$  logic levels and should be at least 1 V higher than  $V_{REF1}$  for best translator operation.

**LOGIC DIAGRAM (POSITIVE LOGIC)**

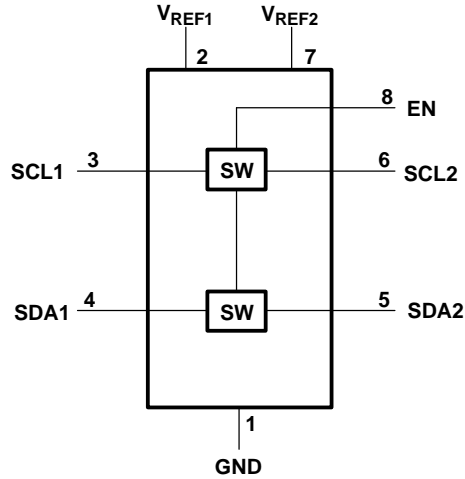

# PCA9306 DUAL BIDIRECTIONAL I2C BUS AND SMBus VOLTAGE-LEVEL TRANSLATOR

SCPS113–OCTOBER 2004–REVISED APRIL 2005

## Absolute Maximum Ratings<sup>(1)</sup>

over operating free-air temperature range (unless otherwise noted)

		MIN	MAX	UNIT
V <sub>REF1</sub>	DC reference voltage range	-0.5	7	V
V <sub>REF2</sub>	DC reference bias voltage range	-0.5	7	V
V <sub>I</sub>	Input voltage range <sup>(2)</sup>	-0.5	7	V
V <sub>I/O</sub>	Input/output voltage range <sup>(2)</sup>	-0.5	7	V
Continuous channel current			128	mA
I <sub>IK</sub>	Input clamp current	V <sub>I</sub> < 0		-50 mA
θ <sub>JA</sub>	Package thermal impedance <sup>(3)</sup>	DCT package		220 °C/W
		DCU package		227 °C/W
T <sub>stg</sub>	Storage temperature range	-65	150	°C

- (1) Stresses beyond those listed under "absolute maximum ratings" may cause permanent damage to the device. These are stress ratings only, and functional operation of the device at these or any other conditions beyond those indicated under "recommended operating conditions" is not implied. Exposure to absolute-maximum-rated conditions for extended periods may affect device reliability.
- (2) The input and input/output negative voltage ratings may be exceeded if the input and output current ratings are observed.
- (3) The package thermal impedance is calculated in accordance with JESD 51-7.

## Recommended Operating Conditions

		MIN	MAX	UNIT
V <sub>I/O</sub>	Input/output voltage	SCL1, SDA1, SCL2, SDA2		0 5 V
V <sub>REF1</sub> <sup>(1)</sup>	Reference voltage	0	5	V
V <sub>REF2</sub> <sup>(1)</sup>	Reference voltage	0	5	V
EN	Enable input voltage	0	5	V
I <sub>PASS</sub>	Pass switch current		64	mA
T <sub>A</sub>	Operating free-air temperature	-40	85	°C

- (1) V<sub>REF1</sub> ≤ V<sub>REF2</sub> - 1 V for best results in level-shifting applications

## Electrical Characteristics

over recommended operating free-air temperature range (unless otherwise noted)

PARAMETER		TEST CONDITIONS		MIN	TYP <sup>(1)</sup>	MAX	UNIT	
V <sub>IK</sub>	Input clamp voltage	I <sub>I</sub> = -18 mA,	EN = 0 V			-1.2	V	
I <sub>IH</sub>	Input leakage current	V <sub>I</sub> = 5 V,	EN = 0 V			5	μA	
C <sub>i</sub> (EN)	Input capacitance	V <sub>I</sub> = 3 V or 0			11		pF	
C <sub>io(off)</sub>	Off capacitance	SCLn, SDAn	V <sub>O</sub> = 3 V or 0, EN = 0 V		4	6	pF	
C <sub>io(on)</sub>	On capacitance	SCLn, SDAn	V <sub>O</sub> = 3 V or 0, EN = 3 V		10.5	12.5	pF	
r <sub>on</sub> <sup>(2)</sup>	On resistance	SCLn, SDAn	V <sub>I</sub> = 0,	I <sub>O</sub> = 64 mA	EN = 4.5 V	3.5	5.5	Ω
					EN = 3 V	4.7	7	
					EN = 2.3 V	6.3	9.5	
			V <sub>I</sub> = 2.4 V	I <sub>O</sub> = 15 mA	EN = 4.5 V	4.8	7.5	
					EN = 3 V	14.7	23	
					EN = 2.3 V	11.3	16.5	

- (1) All typical values are at T<sub>A</sub> = 25°C.
- (2) Measured by the voltage drop between the SCL1 and SCL2, or SDA1 and SDA2 terminals, at the indicated current through the switch. On-state resistance is determined by the lowest voltage of the two terminals.

## AC PERFORMANCE (TRANSLATING DOWN)

### Switching Characteristics

over recommended operating free-air temperature range,  $V_{EN} = 3.3\text{ V}$ ,  $V_{IH} = 3.3\text{ V}$ ,  $V_{IL} = 0$ , and  $V_M = 1.15\text{ V}$  (unless otherwise noted) (see [Figure 1](#))

PARAMETER	FROM (INPUT)	TO (OUTPUT)	$C_L = 50\text{ pF}$		$C_L = 30\text{ pF}$		$C_L = 15\text{ pF}$		UNIT
			MIN	MAX	MIN	MAX	MIN	MAX	
$t_{PLH}$	SCL2 or SDA2	SCL1 or SDA1	0	0.8	0	0.6	0	0.3	ns
$t_{PHL}$			0	1.2	0	1	0	0.5	

### Switching Characteristics

over recommended operating free-air temperature range,  $V_{EN} = 2.5\text{ V}$ ,  $V_{IH} = 2.5\text{ V}$ ,  $V_{IL} = 0$ , and  $V_M = 0.75\text{ V}$  (unless otherwise noted) (see [Figure 1](#))

PARAMETER	FROM (INPUT)	TO (OUTPUT)	$C_L = 50\text{ pF}$		$C_L = 30\text{ pF}$		$C_L = 15\text{ pF}$		UNIT
			MIN	MAX	MIN	MAX	MIN	MAX	
$t_{PLH}$	SCL2 or SDA2	SCL1 or SDA1	0	1	0	0.7	0	0.4	ns
$t_{PHL}$			0	1.3	0	1	0	0.6	

## AC PERFORMANCE (TRANSLATING UP)

### Switching Characteristics

over recommended operating free-air temperature range,  $V_{EN} = 3.3\text{ V}$ ,  $V_{IH} = 2.3\text{ V}$ ,  $V_{IL} = 0$ ,  $V_T = 3.3\text{ V}$ ,  $V_M = 1.15\text{ V}$ , and  $R_L = 300\ \Omega$  (unless otherwise noted) (see [Figure 1](#))

PARAMETER	FROM (INPUT)	TO (OUTPUT)	$C_L = 50\text{ pF}$		$C_L = 30\text{ pF}$		$C_L = 15\text{ pF}$		UNIT
			MIN	MAX	MIN	MAX	MIN	MAX	
$t_{PLH}$	SCL1 or SDA1	SCL2 or SDA2	0	0.9	0	0.6	0	0.4	ns
$t_{PHL}$			0	1.4	0	1.1	0	0.7	

### Switching Characteristics

over recommended operating free-air temperature range,  $V_{EN} = 2.5\text{ V}$ ,  $V_{IH} = 1.5\text{ V}$ ,  $V_{IL} = 0$ ,  $V_T = 2.5\text{ V}$ ,  $V_M = 0.75\text{ V}$ , and  $R_L = 300\ \Omega$  (unless otherwise noted) (see [Figure 1](#))

PARAMETER	FROM (INPUT)	TO (OUTPUT)	$C_L = 50\text{ pF}$		$C_L = 30\text{ pF}$		$C_L = 15\text{ pF}$		UNIT
			MIN	MAX	MIN	MAX	MIN	MAX	
$t_{PLH}$	SCL1 or SDA1	SCL2 or SDA2	0	1	0	0.6	0	0.4	ns
$t_{PHL}$			0	1.3	0	1.3	0	0.8	

PARAMETER MEASUREMENT INFORMATION

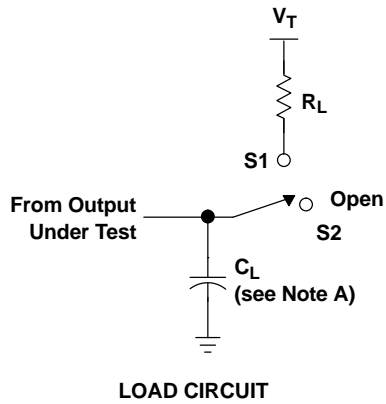

USAGE	SWITCH
Translating up	S1
Translating down	S2

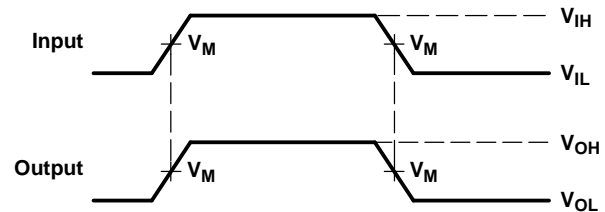

- NOTES: A.  $C_L$  includes probe and jig capacitance.  
 B. All input pulses are supplied by generators having the following characteristics:  $PRR \leq 10 \text{ MHz}$ ,  $Z_O = 50 \Omega$ ,  $t_r \leq 2 \text{ ns}$ ,  $t_f \leq 2 \text{ ns}$ .  
 C. The outputs are measured one at a time, with one transition per measurement.

Figure 1. Load Circuit for Outputs

APPLICATION INFORMATION

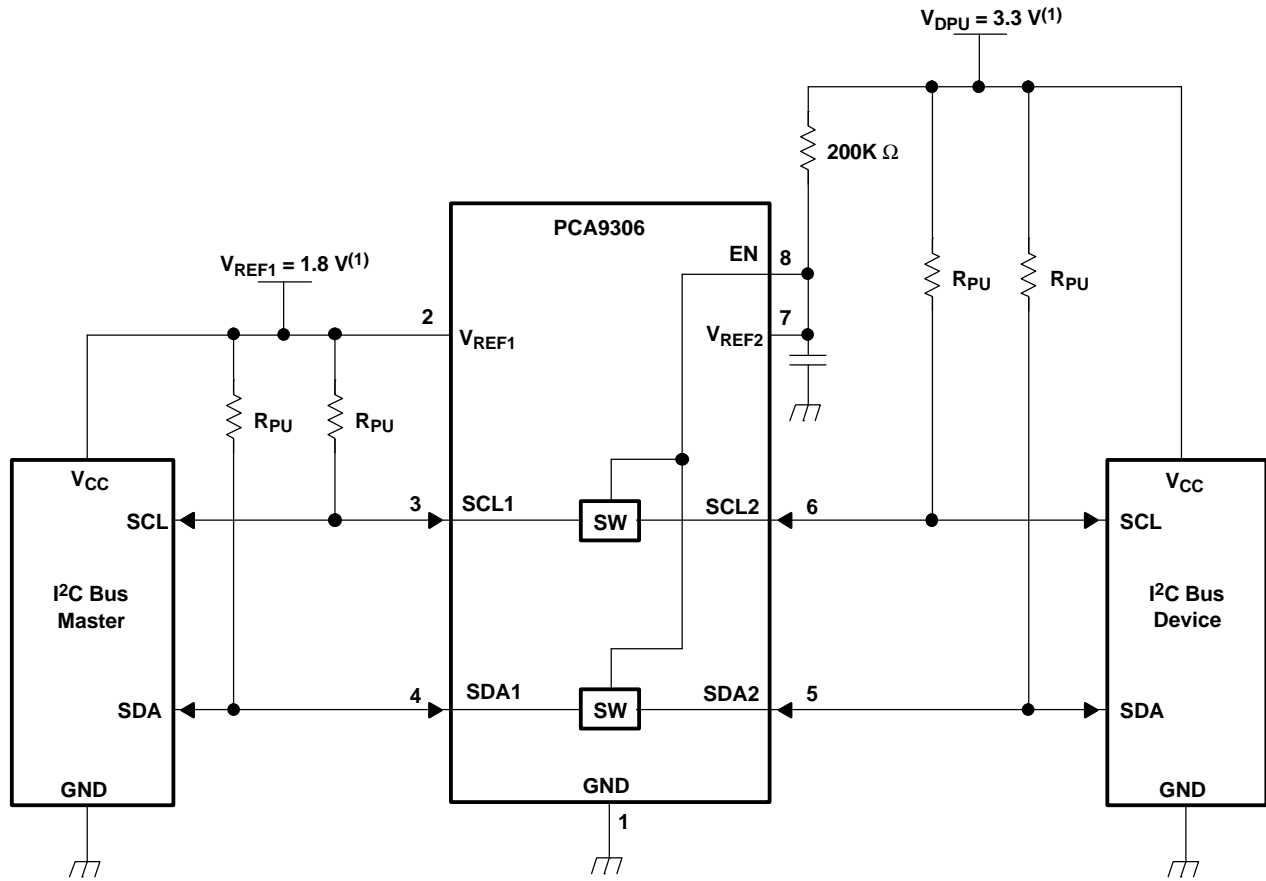

(1) The applied voltages at  $V_{REF1}$  and  $V_{DPU}$  should be such that  $V_{REF2}$  is at least 1 V higher than  $V_{REF1}$  for best translator operation.

**Figure 2. Typical Application Circuit (Switch Always Enabled)**

APPLICATION INFORMATION

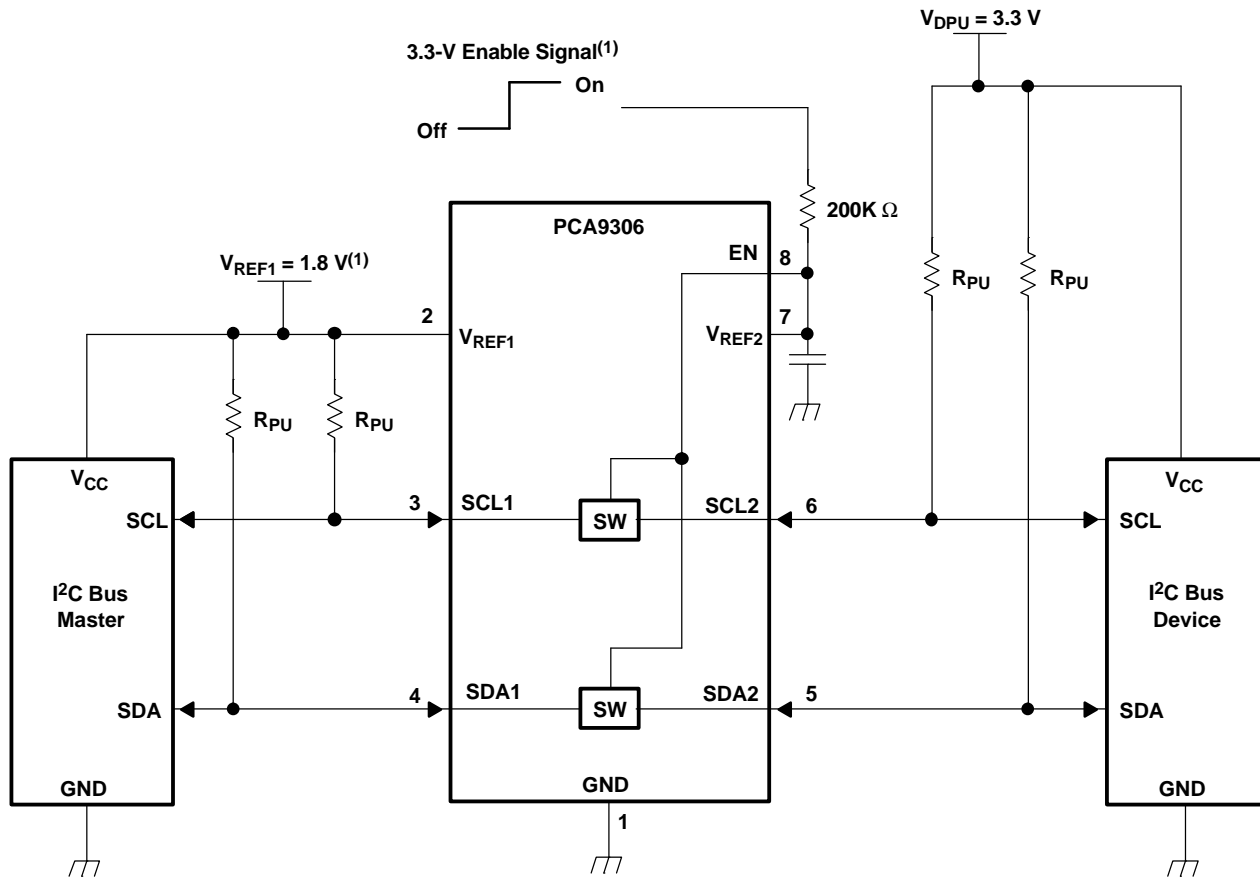

(1) In the enabled mode, the applied enable voltage and the applied voltage at  $V_{REF1}$  should be such that  $V_{REF2}$  is at least 1 V higher than  $V_{REF1}$  for best translator operation.

Figure 3. Typical Application Circuit (Switch Enable Control)

Bidirectional Translation

For the bidirectional clamping configuration (higher voltage to lower voltage or lower voltage to higher voltage), the EN input must be connected to  $V_{REF2}$  and both pins pulled to high-side  $V_{DPU}$  through a pullup resistor (typically 200 kΩ). This allows  $V_{REF2}$  to regulate the EN input. A filter capacitor on  $V_{REF2}$  is recommended. The I2C bus master output can be totem pole or open drain (pullup resistors may be required) and the I2C bus device output can be totem pole or open drain (pullup resistors are required to pull the SCL2 and SDA2 outputs to  $V_{DPU}$ ). However, if either output is totem pole, data must be unidirectional or the outputs must be 3-stateable and be controlled by some direction-control mechanism to prevent high-to-low contentions in either direction. If both outputs are open drain, no direction control is needed.

The reference supply voltage ( $V_{REF1}$ ) is connected to the processor core power-supply voltage. When  $V_{REF2}$  is connected through a 200-kΩ resistor to a 3.3-V to 5.5-V  $V_{DPU}$  power supply, and  $V_{REF1}$  is set between 1.0 V and  $V_{DPU} - 1$  V, the output of each SCL1 and SDA1 has a maximum output voltage equal to  $V_{REF1}$ , and the output of each SCL2 and SDA2 has a maximum output voltage equal to  $V_{DPU}$ .



## APPLICATION INFORMATION

### Application Operating Conditions

see [Figure 2](#)

		MIN	TYP <sup>(1)</sup>	MAX	UNIT
V <sub>REF2</sub>	Reference voltage	V <sub>REF1</sub> + 0.6	2.1	5	V
EN	Enable input voltage	V <sub>REF1</sub> + 0.6	2.1	5	V
V <sub>REF1</sub>	Reference voltage	0	1.5	4.4	V
I <sub>PASS</sub>	Pass switch current		14		mA
I <sub>REF</sub>	Reference-transistor current		5		μA
T <sub>A</sub>	Operating free-air temperature	–40		85	°C

(1) All typical values are at T<sub>A</sub> = 25°C.

### Sizing Pullup Resistor

The pullup resistor value needs to limit the current through the pass transistor, when it is in the on state, to about 15 mA. This ensures a pass voltage of 260 mV to 350 mV. If the current through the pass transistor is higher than 15 mA, the pass voltage also is higher in the on state. To set the current through each pass transistor at 15 mA, the pullup resistor value is calculated as:

$$R_{PU} = \frac{V_{DPU} - 0.35 \text{ V}}{0.015 \text{ A}}$$

The following table summarizes resistor values, reference voltages, and currents at 15 mA, 10 mA, and 3 mA. The resistor value shown in the +10% column (or a larger value) should be used to ensure that the pass voltage of the transistor is 350 mV or less. The external driver must be able to sink the total current from the resistors on both sides of the PCA9306 device at 0.175 V, although the 15 mA applies only to current flowing through the PCA9306 device.

### PULLUP RESISTOR VALUES<sup>(1)(2)</sup>

V <sub>DPU</sub>	PULLUP RESISTOR VALUE (Ω)					
	15 mA		10 mA		3 mA	
	NOMINAL	+10% <sup>(3)</sup>	NOMINAL	+10% <sup>(3)</sup>	NOMINAL	+10% <sup>(3)</sup>
5 V	310	341	465	512	1550	1705
3.3 V	197	217	295	325	983	1082
2.5 V	143	158	215	237	717	788
1.8 V	97	106	145	160	483	532
1.5 V	77	85	115	127	383	422
1.2 V	57	63	85	94	283	312

(1) Calculated for V<sub>OL</sub> = 0.35 V

(2) Assumes output driver V<sub>OL</sub> = 0.175 V at stated current

(3) +10% to compensate for V<sub>DD</sub> range and resistor tolerance

**PACKAGING INFORMATION**

Orderable Device	Status <sup>(1)</sup>	Package Type	Package Drawing	Pins	Package Qty	Eco Plan <sup>(2)</sup>	Lead/Ball Finish	MSL Peak Temp <sup>(3)</sup>
PCA9306DCTR	ACTIVE	SM8	DCT	8	3000	Pb-Free (RoHS)	CU NIPDAU	Level-1-260C-UNLIM
PCA9306DCTT	ACTIVE	SM8	DCT	8	250	Pb-Free (RoHS)	CU NIPDAU	Level-1-260C-UNLIM
PCA9306DCUR	ACTIVE	US8	DCU	8	3000	Pb-Free (RoHS)	CU NIPDAU	Level-1-260C-UNLIM
PCA9306DCURE4	ACTIVE	US8	DCU	8	3000	Pb-Free (RoHS)	CU NIPDAU	Level-1-260C-UNLIM
PCA9306DCUT	ACTIVE	US8	DCU	8	250	Pb-Free (RoHS)	CU NIPDAU	Level-1-260C-UNLIM
PCA9306DCUTE4	ACTIVE	US8	DCU	8	250	Pb-Free (RoHS)	CU NIPDAU	Level-1-260C-UNLIM

<sup>(1)</sup> The marketing status values are defined as follows:

**ACTIVE:** Product device recommended for new designs.

**LIFEBUY:** TI has announced that the device will be discontinued, and a lifetime-buy period is in effect.

**NRND:** Not recommended for new designs. Device is in production to support existing customers, but TI does not recommend using this part in a new design.

**PREVIEW:** Device has been announced but is not in production. Samples may or may not be available.

**OBSELETE:** TI has discontinued the production of the device.

<sup>(2)</sup> Eco Plan - The planned eco-friendly classification: Pb-Free (RoHS) or Green (RoHS & no Sb/Br) - please check <http://www.ti.com/productcontent> for the latest availability information and additional product content details.

**TBD:** The Pb-Free/Green conversion plan has not been defined.

**Pb-Free (RoHS):** TI's terms "Lead-Free" or "Pb-Free" mean semiconductor products that are compatible with the current RoHS requirements for all 6 substances, including the requirement that lead not exceed 0.1% by weight in homogeneous materials. Where designed to be soldered at high temperatures, TI Pb-Free products are suitable for use in specified lead-free processes.

**Green (RoHS & no Sb/Br):** TI defines "Green" to mean Pb-Free (RoHS compatible), and free of Bromine (Br) and Antimony (Sb) based flame retardants (Br or Sb do not exceed 0.1% by weight in homogeneous material)

<sup>(3)</sup> MSL, Peak Temp. -- The Moisture Sensitivity Level rating according to the JEDEC industry standard classifications, and peak solder temperature.

**Important Information and Disclaimer:**The information provided on this page represents TI's knowledge and belief as of the date that it is provided. TI bases its knowledge and belief on information provided by third parties, and makes no representation or warranty as to the accuracy of such information. Efforts are underway to better integrate information from third parties. TI has taken and continues to take reasonable steps to provide representative and accurate information but may not have conducted destructive testing or chemical analysis on incoming materials and chemicals. TI and TI suppliers consider certain information to be proprietary, and thus CAS numbers and other limited information may not be available for release.

In no event shall TI's liability arising out of such information exceed the total purchase price of the TI part(s) at issue in this document sold by TI to Customer on an annual basis.

DCT (R-PDSO-G8)

PLASTIC SMALL-OUTLINE PACKAGE



- NOTES: A. All linear dimensions are in millimeters.  
 B. This drawing is subject to change without notice.  
 C. Body dimensions do not include mold flash or protrusion  
 D. Falls within JEDEC MO-187 variation DA.



## IMPORTANT NOTICE

Texas Instruments Incorporated and its subsidiaries (TI) reserve the right to make corrections, modifications, enhancements, improvements, and other changes to its products and services at any time and to discontinue any product or service without notice. Customers should obtain the latest relevant information before placing orders and should verify that such information is current and complete. All products are sold subject to TI's terms and conditions of sale supplied at the time of order acknowledgment.

TI warrants performance of its hardware products to the specifications applicable at the time of sale in accordance with TI's standard warranty. Testing and other quality control techniques are used to the extent TI deems necessary to support this warranty. Except where mandated by government requirements, testing of all parameters of each product is not necessarily performed.

TI assumes no liability for applications assistance or customer product design. Customers are responsible for their products and applications using TI components. To minimize the risks associated with customer products and applications, customers should provide adequate design and operating safeguards.

TI does not warrant or represent that any license, either express or implied, is granted under any TI patent right, copyright, mask work right, or other TI intellectual property right relating to any combination, machine, or process in which TI products or services are used. Information published by TI regarding third-party products or services does not constitute a license from TI to use such products or services or a warranty or endorsement thereof. Use of such information may require a license from a third party under the patents or other intellectual property of the third party, or a license from TI under the patents or other intellectual property of TI.

Reproduction of information in TI data books or data sheets is permissible only if reproduction is without alteration and is accompanied by all associated warranties, conditions, limitations, and notices. Reproduction of this information with alteration is an unfair and deceptive business practice. TI is not responsible or liable for such altered documentation.

Resale of TI products or services with statements different from or beyond the parameters stated by TI for that product or service voids all express and any implied warranties for the associated TI product or service and is an unfair and deceptive business practice. TI is not responsible or liable for any such statements.

Following are URLs where you can obtain information on other Texas Instruments products and application solutions:

<b>Products</b>		<b>Applications</b>	
Amplifiers	<a href="http://amplifier.ti.com">amplifier.ti.com</a>	Audio	<a href="http://www.ti.com/audio">www.ti.com/audio</a>
Data Converters	<a href="http://dataconverter.ti.com">dataconverter.ti.com</a>	Automotive	<a href="http://www.ti.com/automotive">www.ti.com/automotive</a>
DSP	<a href="http://dsp.ti.com">dsp.ti.com</a>	Broadband	<a href="http://www.ti.com/broadband">www.ti.com/broadband</a>
Interface	<a href="http://interface.ti.com">interface.ti.com</a>	Digital Control	<a href="http://www.ti.com/digitalcontrol">www.ti.com/digitalcontrol</a>
Logic	<a href="http://logic.ti.com">logic.ti.com</a>	Military	<a href="http://www.ti.com/military">www.ti.com/military</a>
Power Mgmt	<a href="http://power.ti.com">power.ti.com</a>	Optical Networking	<a href="http://www.ti.com/opticalnetwork">www.ti.com/opticalnetwork</a>
Microcontrollers	<a href="http://microcontroller.ti.com">microcontroller.ti.com</a>	Security	<a href="http://www.ti.com/security">www.ti.com/security</a>
		Telephony	<a href="http://www.ti.com/telephony">www.ti.com/telephony</a>
		Video & Imaging	<a href="http://www.ti.com/video">www.ti.com/video</a>
		Wireless	<a href="http://www.ti.com/wireless">www.ti.com/wireless</a>

Mailing Address: Texas Instruments  
Post Office Box 655303 Dallas, Texas 75265