

SYNCHRONOUS BOOST CONVERTER WITH 1.1A SWITCH AND INTEGRATED LDO

FEATURES

- Synchronous, 95% Efficient, Boost Converter With 500-mA Output Current From 1.8-V Input
- Integrated 200-mA Reverse Voltage Protected LDO for DC/DC Output Voltage Post Regulation or Second Output Voltage
- 40- μ A (Typical) Total Device Quiescent Current
- Input Voltage Range: 1.8-V to 5.5-V
- Fixed and Adjustable Output Voltage Options up to 5.5-V
- Power Save Mode for Improved Efficiency at Low Output Power
- Low Battery Comparator
- Power Good Output
- Low EMI-Converter (Integrated Antiringing Switch)
- Load Disconnect During Shutdown
- Overtemperature Protection
- Available in a Small 4mm x 4mm QFN-16 or in a TSSOP-16 Package

APPLICATIONS

- All Single Cell Li or Dual Cell Battery or USB Powered Products as MP-3 Player, PDAs, and Other Portable Equipment
- Dual Input or Dual Output Mode
- Simple Li-Ion to 3.3-V Conversion

DESCRIPTION

The TPS6112x devices provide a complete power supply solution for products powered by either a one-cell Li-Ion or Li-Polymer or a two up to 4 cells Alkaline, NiCd or NiMH batteries. The devices can generate two stable output voltages that are either adjusted by an external resistor divider or fixed internally on the chip. It also provides a simple solution for generating 3.3 V out of a one-cell Li-Ion or Li-Polymer battery at a maximum output current of at least 200 mA with supply voltages down to 1.8 V. The implemented boost converter is based on a fixed frequency, pulse-width-modulation (PWM) controller using a synchronous rectifier to obtain maximum efficiency. The maximum peak current in the boost switch is limited to a value of 1600 mA.

The converter can be disabled to minimize battery drain. During shutdown, the load is completely disconnected from the battery. A low-EMI mode is implemented to reduce ringing and in effect lower radiated electromagnetic energy when the converter enters the discontinuous conduction mode. A power good output at the boost stage simplifies control of any connected circuits like cascaded power supply stages or microprocessors.

The built-in LDO can be used for a second output voltage derived either from the boost output or directly from the battery. The LDO can be enabled separately i.e., using the power good of the boost stage. The device is packaged in a 16-pin QFN package measuring 4 mm x 4 mm (RSA) or in a 16-pin TSSOP (PW) package.

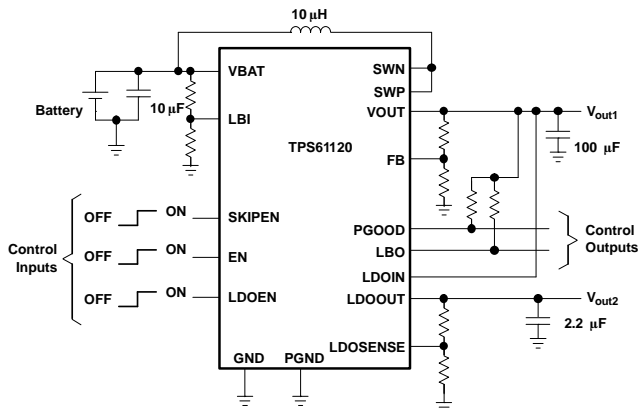

Please be aware that an important notice concerning availability, standard warranty, and use in critical applications of Texas Instruments semiconductor products and disclaimers thereto appears at the end of this data sheet.



These devices have limited built-in ESD protection. The leads should be shorted together or the device placed in conductive foam during storage or handling to prevent electrostatic damage to the MOS gates. This integrated circuit can be damaged by ESD. Texas Instruments recommends that all integrated circuits be handled with appropriate precautions. Failure to observe proper handling and installation procedures can cause damage.

AVAILABLE OUTPUT VOLTAGE OPTIONS⁽¹⁾

T _A	OUTPUT VOLTAGE DC/DC	OUTPUT VOLTAGE LDO	PACKAGE	PART NUMBER ⁽²⁾
40°C to 85°C	Adjustable	Adjustable	16-Pin TSSOP	TPS61120PW
	3.3 V	1.5 V		TPS61121PW
	3.6 V	3.3 V		TPS61122PW
	Adjustable	Adjustable	16-Pin QFN 4x4mm	TPS61120RSA
	3.3 V	1.5 V		TPS61121RSA

(1) Contact the factory to check availability of other fixed output voltage versions.

(2) The packages are available taped and reeled. Add R suffix to device type (e.g., TPS61120PWR or TPS61120RSAR) to order quantities of 2000 devices per reel for the TSSOP (PW) package and 3000 devices per reel for the QFN (RSA) package.

ABSOLUTE MAXIMUM RATINGS

over operating free-air temperature range unless otherwise noted⁽¹⁾

	TPS6112x
Input voltage range on FB	-0.3 V to 3.6 V
Input voltage range on SWN, SWP	-0.3 V to 10 V
Input voltage range on VOUT, LDOIN, LDOOUT, LDOEN, LDOSENSE, PGOOD, LBO, VBAT, LBI, SKIPEN, EN	-0.3 V to 7 V
Maximum junction temperature T _J	-40°C to 150°C
Storage temperature range T _{stg}	-65°C to 150°C

(1) Stresses beyond those listed under "absolute maximum ratings" may cause permanent damage to the device. These are stress ratings only, and functional operation of the device at these or any other conditions beyond those indicated under "recommended operating conditions" is not implied. Exposure to absolute-maximum-rated conditions for extended periods may affect device reliability.

RECOMMENDED OPERATING CONDITIONS

	MIN	NOM	MAX	UNIT
Supply voltage at VBAT, V _I	1.8		5.5	V
Operating ambient temperature range, T _A	-40		85	°C
Operating virtual junction temperature range, T _J	-40		125	°C

ELECTRICAL CHARACTERISTICS

over recommended free-air temperature range and over recommended input voltage range (typical at an ambient temperature range of 25°C) (unless otherwise noted)

DC/DC STAGE						
PARAMETER		TEST CONDITIONS	MIN	TYP	MAX	UNIT
V_I	Input voltage range		1.8		5.5	V
V_O	Adjustable output voltage range (TPS61120)		2.5		5.5	V
V_{ref}	Reference voltage		485	500	515	mV
f	Oscillator frequency		400	500	600	kHz
I_{SW}	Switch current limit	VOUT = 3.3 V	1100	1300	1600	mA
	Startup current limit		0.4 × I_{SW}			mA
	SWN switch on resistance	VOUT = 3.3 V		200	350	mΩ
	SWP switch on resistance	VOUT = 3.3 V		250	500	mΩ
Total accuracy (including line and load regulation)			-3%		±3%	
DC/DC quiescent current	into VBAT	$I_O = 0$ mA, $V_{EN} = V_{BAT} = 1.8$ V, VOUT = 3.3 V, ENLDO = 0		10	25	μA
	into VOUT	$I_O = 0$ mA, $V_{EN} = V_{BAT} = 1.8$ V, VOUT = 3.3 V, ENLDO = 0		10	25	μA
DC/DC shutdown current		$V_{EN} = 0$ V		0.2	1	μA
LDO STAGE						
$V_{I(LDO)}$	Input voltage range		1.8		7	V
$V_{O(LDO)}$	Adjustable output voltage range (TPS61120)		0.9		5.5	V
$I_{O(max)}$	Output current		200	320		mA
	LDO short circuit current limit				500	mA
	Minimum voltage drop	$I_O = 200$ mA			300	mV
Total accuracy (including line and load regulation)			$I_O \geq 1$ mA		±3%	
Line regulation			LDOIN change from 1.8 V to 2.6 V at 100 mA, LDOOUT = 1.5 V		0.6%	
Load regulation			Load change from 10% to 90%, LDOIN = 3.3 V		0.6%	
LDO quiescent current		LDOIN = 7 V, VBAT = 1.8 V, EN = VBAT		20	30	μA
LDO shutdown current		LDOEN = 0 V, LDOIN = 7 V		0.1	1	μA
CONTROL STAGE						
V_{IL}	LBI voltage threshold	V_{LBI} voltage decreasing	490	500	510	mV
	LBI input hysteresis		10			mV
	LBI input current	EN = VBAT or GND		0.01	0.1	μA
	LBO output low voltage	$V_O = 3.3$ V, $I_{OI} = 100$ μA		0.04	0.4	V
	LBO output low current			100		μA
	LBO output leakage current	$V_{LBO} = 7$ V		0.01	0.1	μA
V_{IL}	EN, SKIPEN input low voltage		0.2 × VBAT			V
V_{IH}	EN, SKIPEN input high voltage		0.8 × VBAT			V
V_{IL}	LDOEN input low voltage		0.2 × V_{LDOIN}			V
V_{IH}	LDOEN input high voltage		0.8 × V_{LDOIN}			V
EN, SKIPEN input current		Clamped on GND or VBAT		0.01	0.1	μA

CONTROL STAGE					
Power-Good threshold	$V_O = 3.3\text{ V}$	$0.9 \times V_O$	$0.92 \times V_O$	$0.95 \times V_O$	V
Power-Good delay			30		μs
Power-Good output low voltage	$V_O = 3.3\text{ V}, I_{OI} = 100\ \mu\text{A}$		0.04	0.4	V
Power-Good output low current			100		μA
Power-Good output leakage current	$V_{PG} = 7\text{ V}$		0.01	0.1	μA
Over-Temperature protection			140		$^{\circ}\text{C}$
Over-Temperature hysteresis			20		$^{\circ}\text{C}$

PIN ASSIGNMENTS

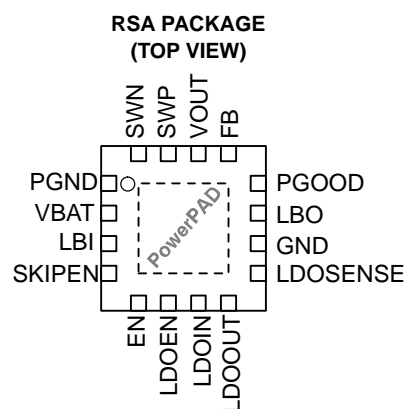
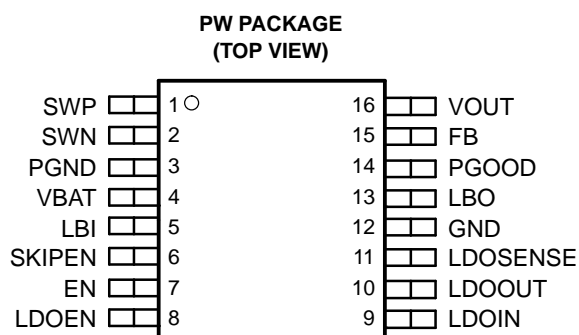

Terminal Functions

NAME	TERMINAL NO.		I/O	DESCRIPTION
	PW	RSA		
EN	7	5	I	DC/DC-enable input. (1/VBAT enabled, 0/GND disabled)
FB	15	13	I	DC/DC voltage feedback of adjustable versions
GND	12	10	I/O	Control/logic ground
LBI	5	3	I	Low battery comparator input (comparator enabled with EN)
LBO	13	11	O	Low battery comparator output (open drain)
LDOEN	8	6	I	LDO-enable input (1/LDOIN enabled, 0/GND disabled)
LDOOUT	10	8	O	LDO output
LDOIN	9	7	I	LDO input
LDOSENSE	11	9	I	LDO feedback for voltage adjustment, must be connected to LDOOUT at fixed output voltage versions
SWP	1	15	I	DC/DC rectifying switch input
PGND	3	1	I/O	Power ground
PGOOD	14	12	O	DC/DC output power good (1 : good, 0 : failure) (open drain)
SKIPEN	6	4	I	Enable/disable power save mode (1: VBAT enabled, 0: GND disabled)
SWN	2	16	I	DC/DC switch input
VBAT	4	2	I	Supply pin
VOUT	16	14	O	DC/DC output
PowerPAD™				Must be soldered to achieve appropriate power dissipation. Should be connected to PGND.

FUNCTIONAL BLOCK DIAGRAM

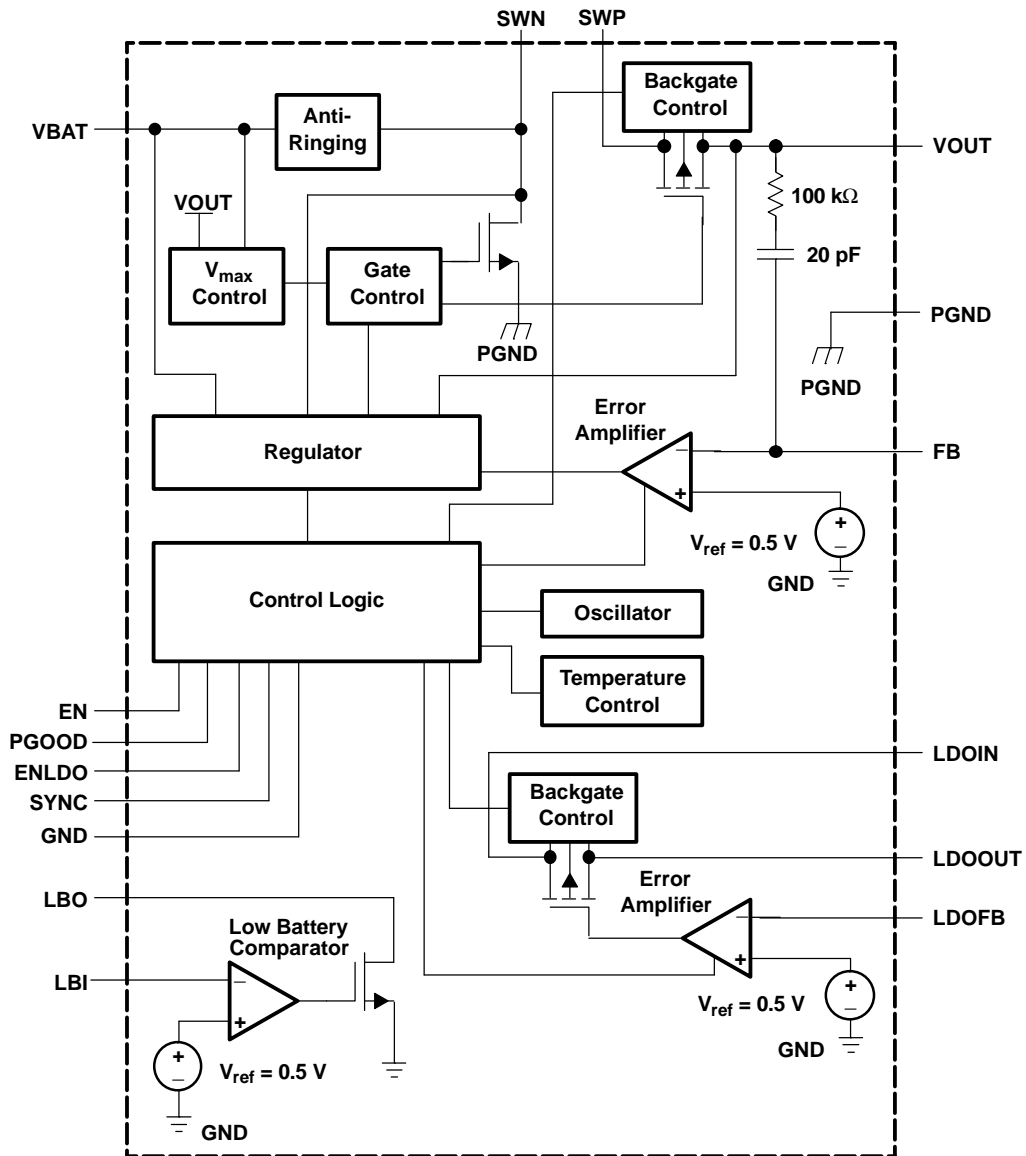

TYPICAL CHARACTERISTICS

Table of Graphs

BOOST CONVERTER		FIGURE
Maximum output current	vs Input voltage	1, 2
Efficiency	vs Output current (TPS61120) ($V_O = 2.5\text{ V}$, $V_I = 1.8\text{ V}$)	3
	vs Output current (TPS61121) ($V_O = 3.3\text{ V}$, $V_I = 1.8\text{ V}$, 2.4 V)	4
	vs Output current (TPS61120) ($V_O = 5.0\text{ V}$, $V_I = 2.4\text{ V}$, 3.3 V)	5
	vs Input voltage (TPS61121)	6
Output voltage	vs Output current (TPS61121)	7
No-load supply current into VBAT	vs Input voltage (TPS61121)	8
No-load supply current into VOUT	vs Input voltage (TPS61121)	9
Waveforms	Output voltage in continuous mode (TPS61121)	10
	Output voltage in power save mode (TPS61121)	11
	Load transient response (TPS61121)	12
	Line transient response (TPS61121)	13
	Start-up after enable (TPS61121)	14
LDO		
Maximum output current	vs Input voltage ($V_O = 2.5\text{ V}$, 3.3 V)	15
	vs Input voltage ($V_O = 1.5\text{ V}$, 1.8 V)	16
Output voltage	vs Output current (TPS61122)	17
Dropout voltage	vs Output current (TPS61121, TPS61122)	18
Supply current into LDOIN	vs LDOIN input voltage (TPS61121)	19
PSRR	vs Frequency (TPS61121)	20
Waveforms	Load transient response (TPS61121)	21
	Line transient response (TPS61121)	22
	Start-up after enable (TPS61121)	23

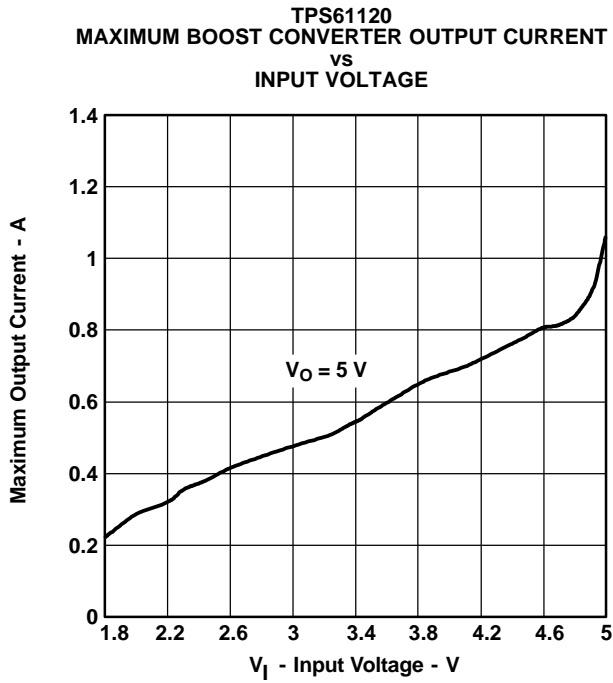

Figure 1.

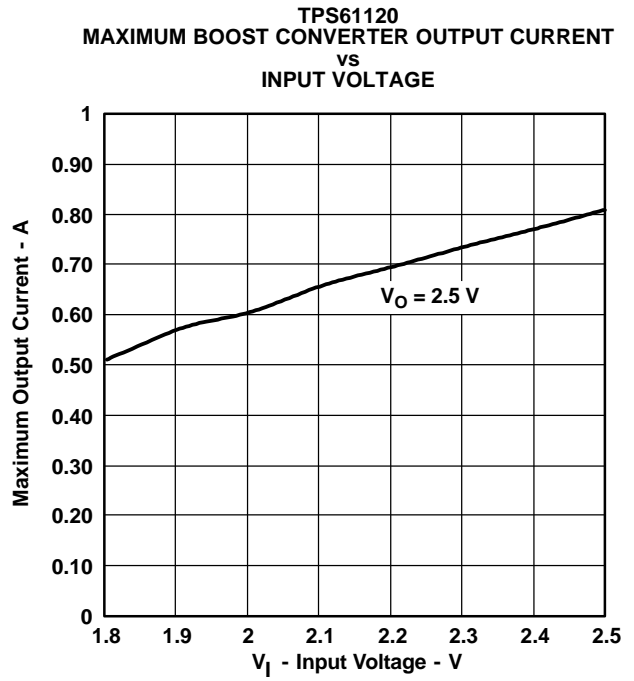

Figure 2.

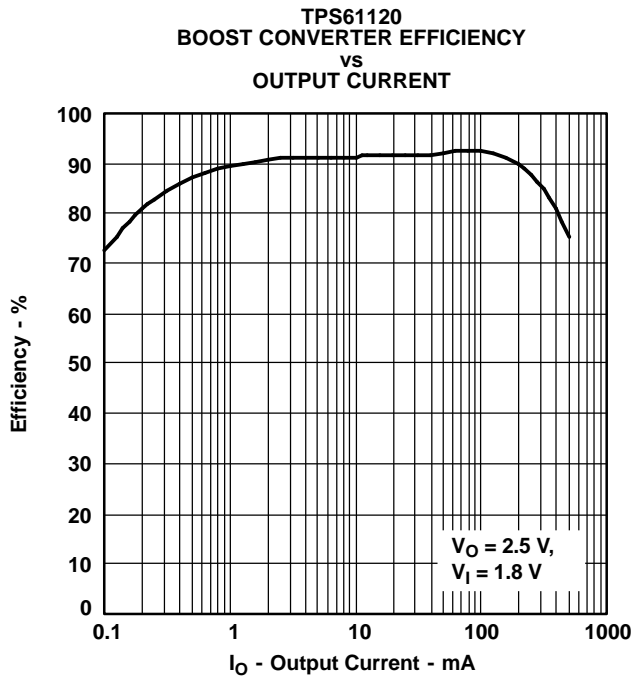

Figure 3.

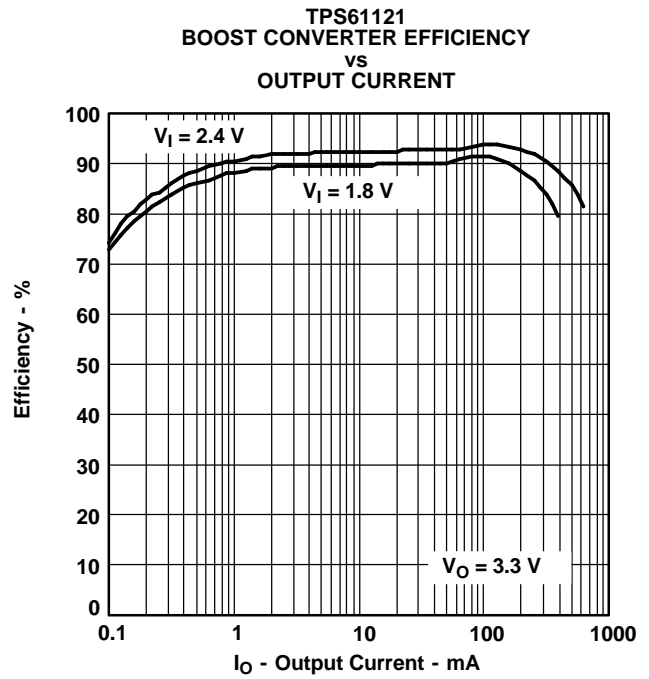

Figure 4.

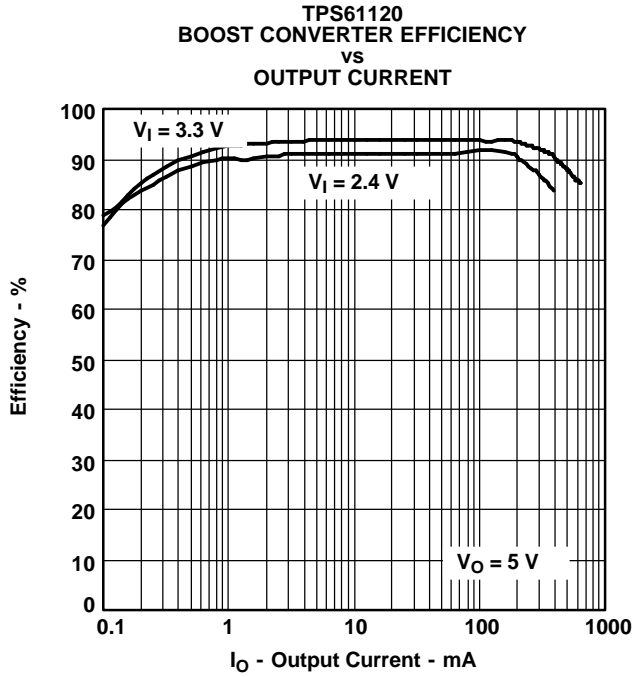

Figure 5.

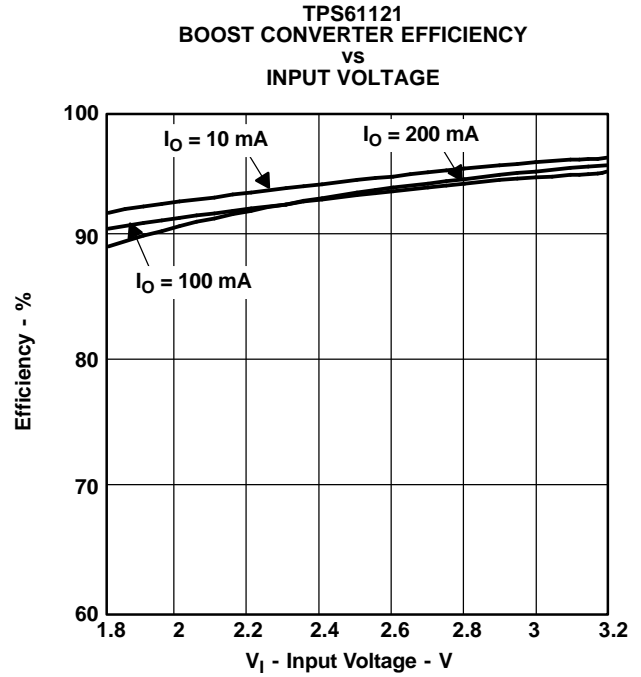

Figure 6.

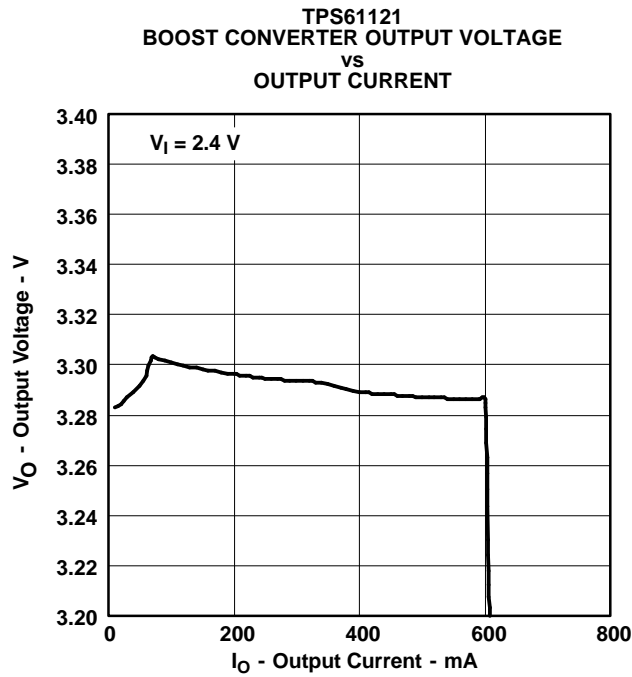

Figure 7.

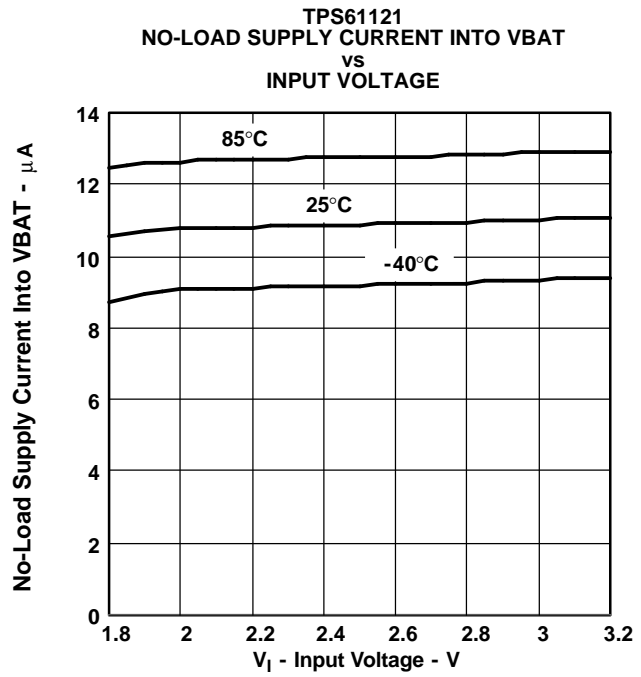

Figure 8.

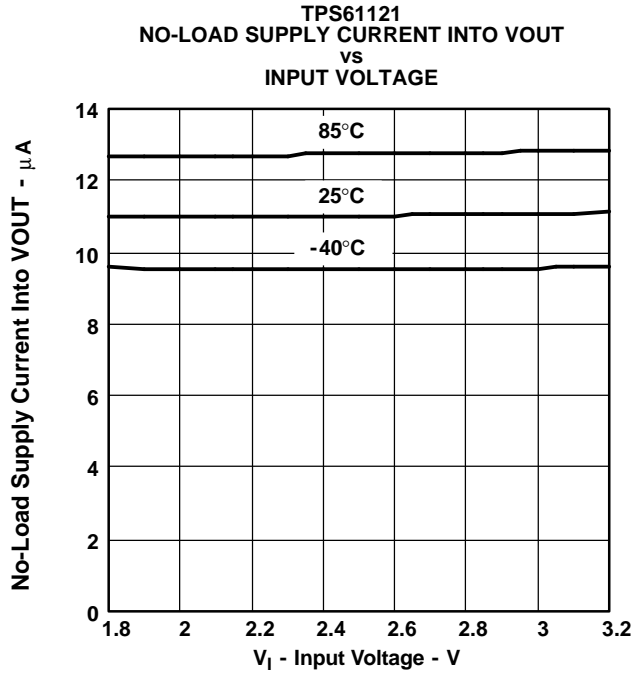

Figure 9.

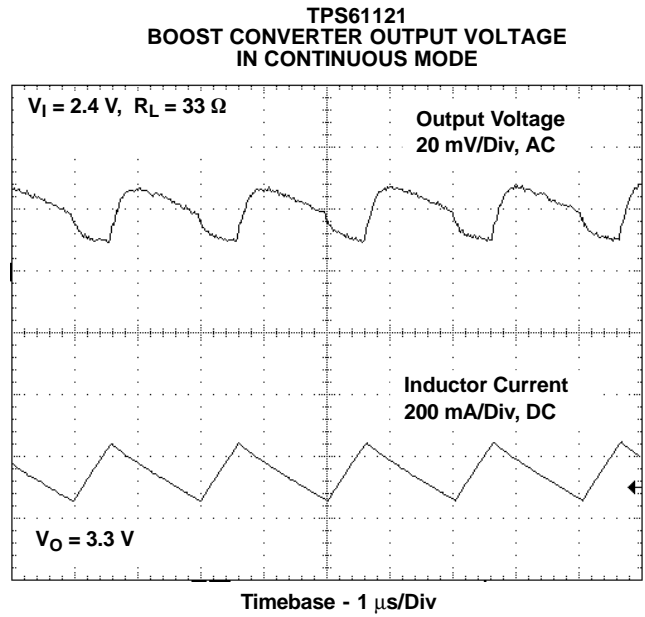

Figure 10.

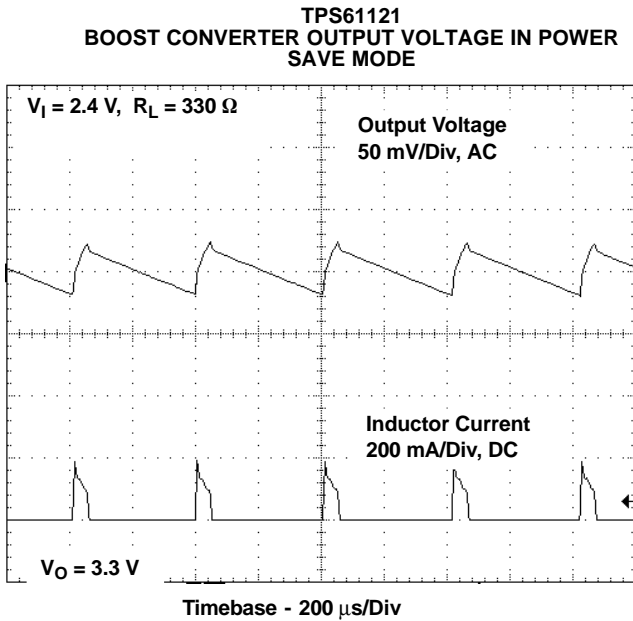

Figure 11.

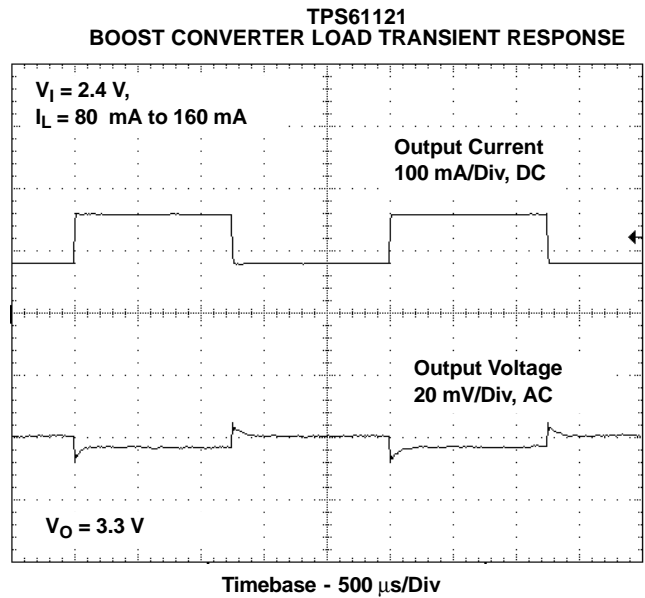
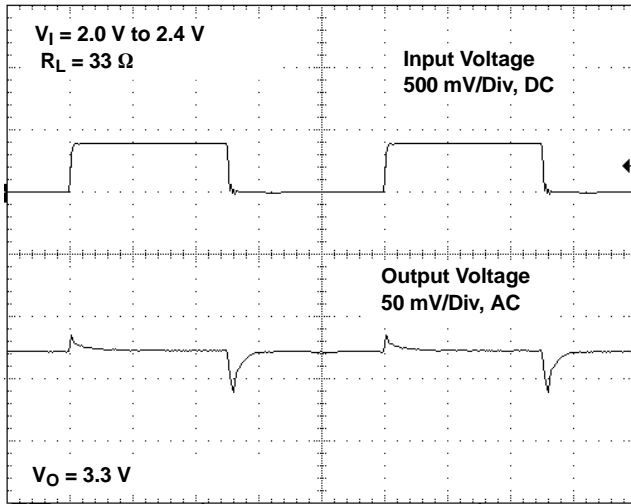

Figure 12.

TPS61121
BOOST CONVERTER LINE TRANSIENT RESPONSE



Timebase - 200 μ s/Div

Figure 13.

TPS61121
BOOST CONVERTER START-UP AFTER ENABLE

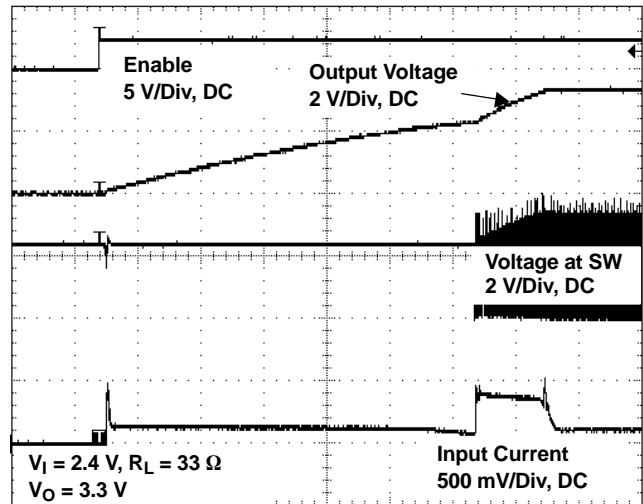

Timebase - 400 μ s/Div

Figure 14.

TPS61120
MAXIMUM LDO OUTPUT CURRENT
vs
LDO INPUT VOLTAGE

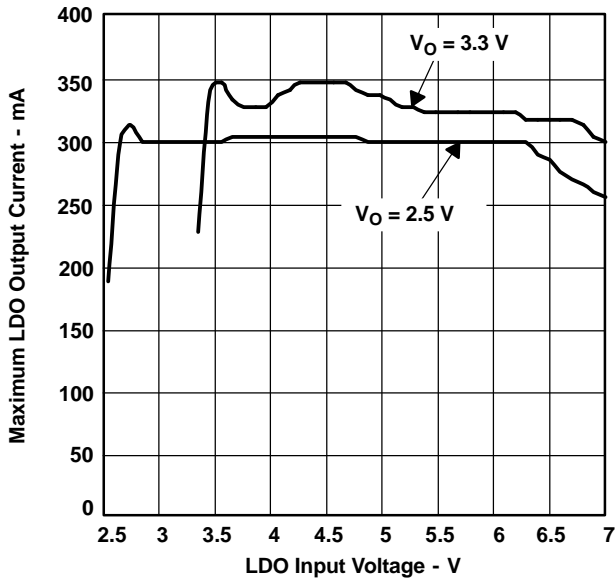

Figure 15.

TPS61120
MAXIMUM LDO OUTPUT CURRENT
vs
LDO INPUT VOLTAGE

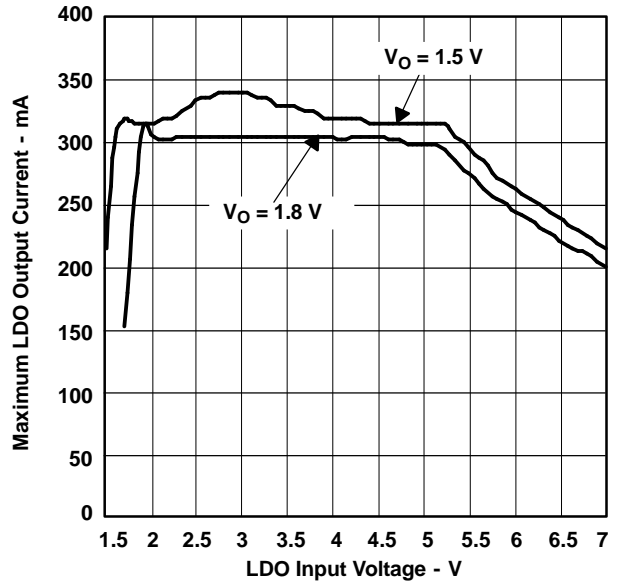

Figure 16.

TPS61122
 LDO OUTPUT VOLTAGE
 vs
 LDO OUTPUT CURRENT

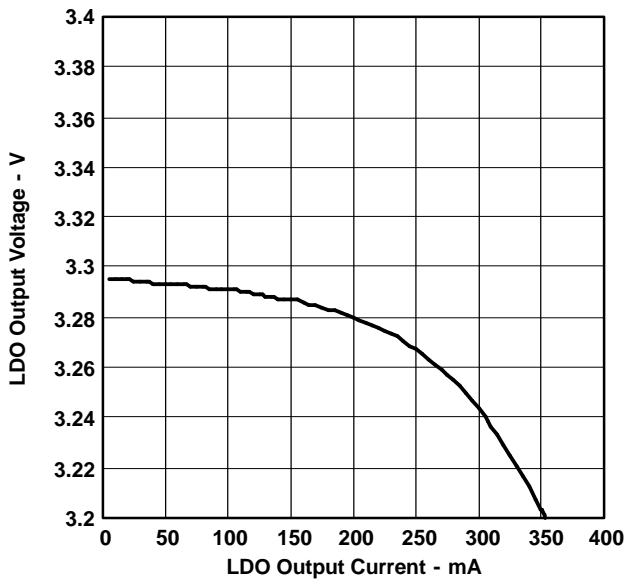

Figure 17.

LDO DROPOUT VOLTAGE
 vs
 LDO OUTPUT CURRENT

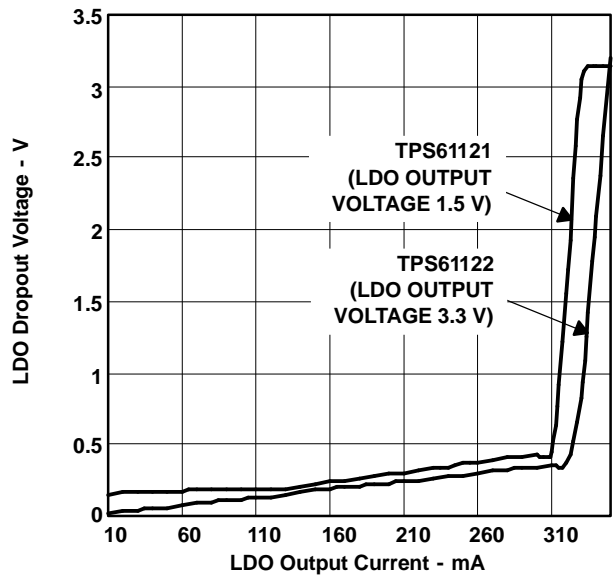

Figure 18.

TPS61121
 SUPPLY CURRENT INTO LDOIN
 vs
 LDO INPUT VOLTAGE

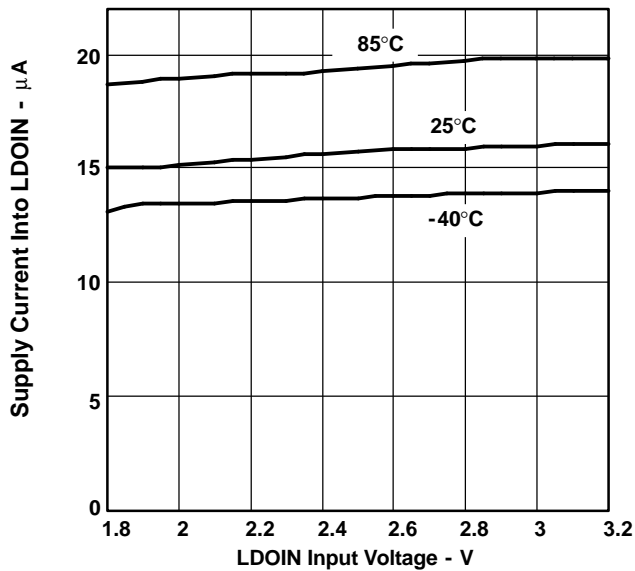

Figure 19.

TPS61121
 PSRR
 vs
 FREQUENCY

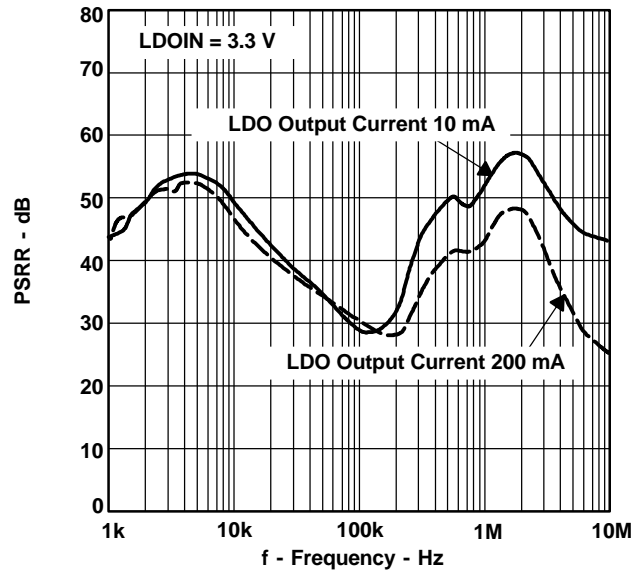
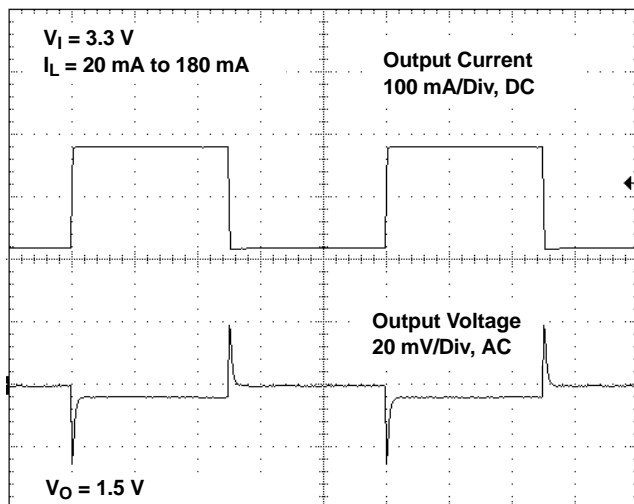

Figure 20.

**TPS61121
LDO LOAD TRANSIENT RESPONSE**



Timebase - 500 $\mu\text{s/Div}$

Figure 21.

**TPS61121
LDO LINE TRANSIENT RESPONSE**

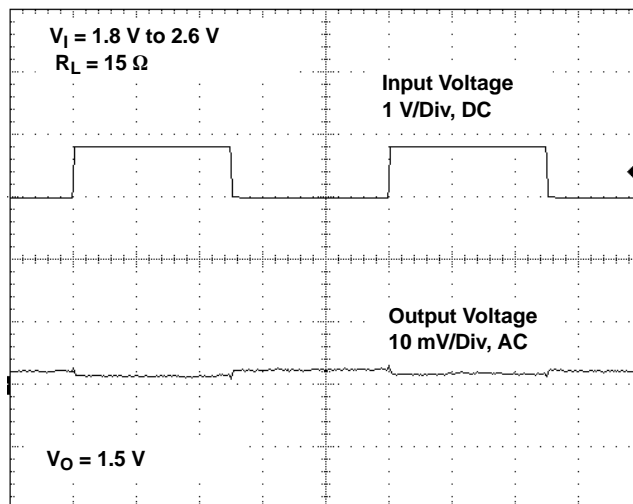

Timebase - 2 ms/Div

Figure 22.

**TPS61121
LDO START-UP AFTER ENABLE**

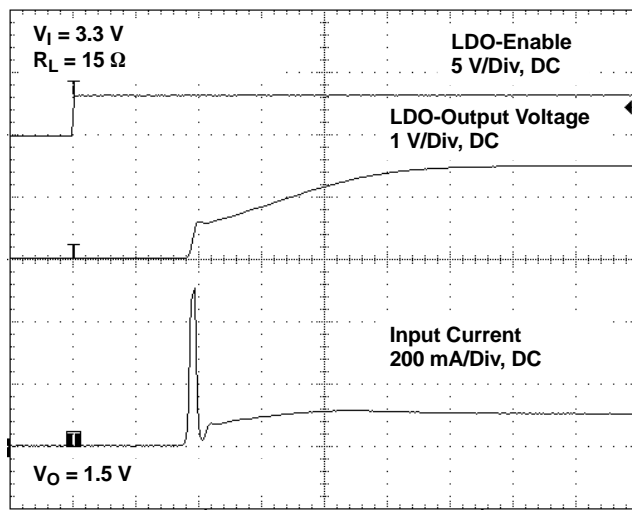

Timebase - 20 $\mu\text{s/Div}$

Figure 23.

APPLICATION INFORMATION

DESIGN PROCEDURE

The TPS6112x dc/dc converters are intended for systems powered by a dual or triple cell NiCd or NiMH battery with a typical terminal voltage between 1.8 V and 5.5 V. They can also be used in systems powered by one-cell Li-Ion with a typical stack voltage between 2.5 V and 4.2 V. Additionally, two or three primary and secondary alkaline battery cells can be the power source in systems where the TPS6112x is used.

Programming the Output Voltage

DC/DC Converter

The output voltage of the TPS61120 dc/dc converter section can be adjusted with an external resistor divider. The typical value of the voltage on the FB pin is 500 mV. The maximum allowed value for the output voltage is 5.5 V. The current through the resistive divider should be about 100 times greater than the current into the FB pin. The typical current into the FB pin is 0.01 μ A and the voltage across R6 is typically 500 mV. Based on those two values, the recommended value for R6 should be lower than 500 k Ω , in order to set the divider current at 1 μ A or higher. Because of internal compensation circuitry the value for this resistor should be in the range of 200 k Ω . From that, the value of resistor R3, depending on the needed output voltage (V_O), can be calculated using Equation 1:

$$R3 = R6 \times \left(\frac{V_O}{V_{FB}} - 1 \right) = 180 \text{ k}\Omega \times \left(\frac{V_O}{500 \text{ mV}} - 1 \right) \quad (1)$$

If as an example, an output voltage of 3.3 V is needed, a 1-M Ω resistor should be chosen for R3. If for any reason the value for R6 is chosen significantly lower than 200 k Ω additional capacitance in parallel to R3 is recommended. The required capacitance value can be easily calculated using Equation 2.

$$C_{\text{par}R3} = 20 \text{ pF} \times \left(\frac{200 \text{ k}\Omega}{R6} - 1 \right) \quad (2)$$

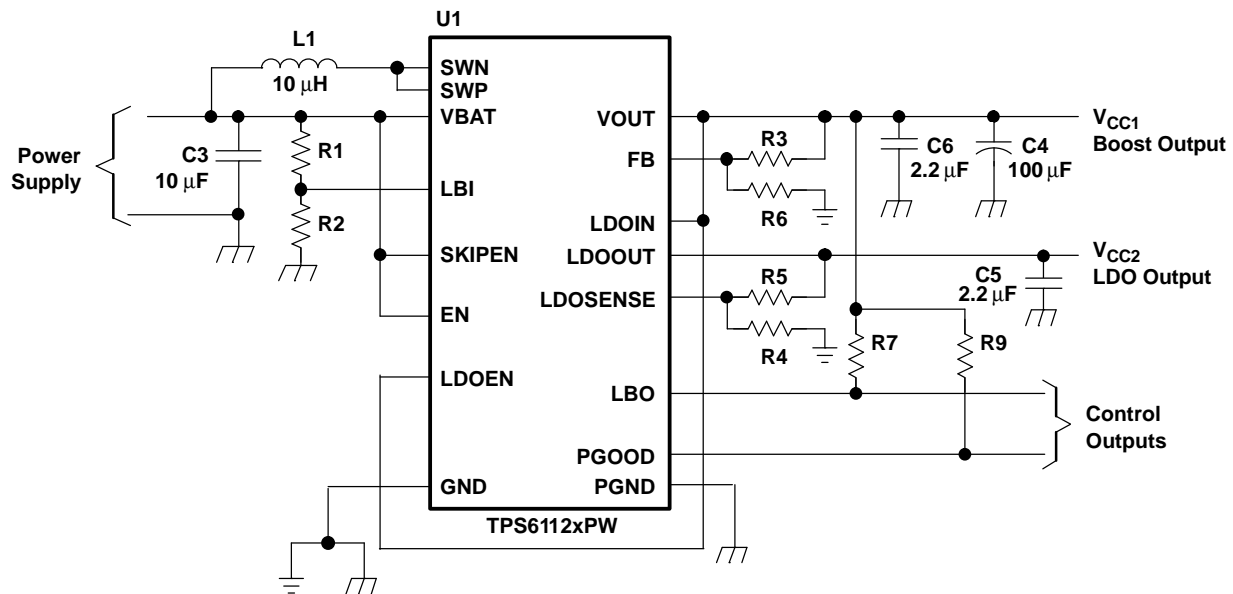

Figure 24. Typical Application Circuit for Adjustable Output Voltage Option

LDO

Programming the output voltage at the LDO follows almost the same rules as in the dc/dc converter section. The maximum programmable output voltage at the LDO is 5.5 V. Since reference and internal feedback circuitry are similar, as they are at the boost converter section, R4 also should be in the 200-kΩ range. The calculation of the value of R5 can be done using the following Equation 3:

$$R5 = R4 \times \left(\frac{V_O}{V_{FB}} - 1 \right) = 180 \text{ k}\Omega \times \left(\frac{V_O}{500 \text{ mV}} - 1 \right) \quad (3)$$

If as an example, an output voltage of 1.5 V is needed, a 360 kΩ-resistor should be chosen for R5.

Programming the LBI/LBO Threshold Voltage

The current through the resistive divider should be about 100 times greater than the current into the LBI pin. The typical current into the LBI pin is 0.01 μA, and the voltage across R2 is equal to the LBI voltage threshold that is generated on-chip, which has a value of 500 mV. The recommended value for R2 is therefore in the range of 500 kΩ. From that, the value of resistor R1, depending on the desired minimum battery voltage V_{BAT} , can be calculated using Equation 4.

$$R1 = R2 \times \left(\frac{V_{BAT}}{V_{LBI} - \text{threshold}} - 1 \right) = 390 \text{ k}\Omega \times \left(\frac{V_{BAT}}{500 \text{ mV}} - 1 \right) \quad (4)$$

The output of the low battery supervisor is a simple open-drain output that goes active low if the dedicated battery voltage drops below the programmed threshold voltage on LBI. The output requires a pullup resistor with a recommended value of 1 MΩ. The maximum voltage which is used to pull up the LBO outputs should not exceed the output voltage of the dc/dc converter. If not used, the LBO pin can be left floating or tied to GND.

Inductor Selection

A boost converter normally requires two main passive components for storing energy during the conversion. A boost inductor and a storage capacitor at the output are required. To select the boost inductor, it is recommended to keep the possible peak inductor current below the current limit threshold of the power switch in the chosen configuration. For example, the current limit threshold of the TPS6112x's switch is 1600 mA at an output voltage of 3.3 V. The highest peak current through the inductor and the switch depends on the output load, the input (V_{BAT}), and the output voltage (V_{OUT}). Estimation of the maximum average inductor current can be done using Equation 5:

$$I_L = I_{OUT} \times \frac{V_{OUT}}{V_{BAT} \times 0.8} \quad (5)$$

For example, for an output current of 250 mA at 3.3 V, at least 575 mA of current flows through the inductor at a minimum input voltage of 1.8 V.

The second parameter for choosing the inductor is the desired current ripple in the inductor. Normally, it is advisable to work with a ripple in the range of 20% of the average inductor current. A smaller ripple reduces the magnetic hysteresis losses in the inductor, as well as output voltage ripple and EMI. But in the same way, regulation time at load changes rises. In addition, a larger inductor increases the total system costs. With those parameters, it is possible to calculate the value for the inductor by using Equation 6:

$$L = \frac{V_{BAT} \times (V_{OUT} - V_{BAT})}{\Delta I_L \times f \times V_{OUT}} \quad (6)$$

Parameter f is the switching frequency and ΔI_L is the ripple current in the inductor, i.e., $20\% \times I_L$. In this example, the desired inductor value is in the range of 14 μH. In typical applications a 10 μH inductor is recommended. The minimum possible inductor value is 4.7 μH. With the calculated inductance value and current, it is possible to choose a suitable inductor. Care has to be taken that load transients and losses in the circuit can lead to higher currents as estimated in Equation 5. Also, the losses in the inductor caused by magnetic hysteresis losses and copper losses are a major parameter for total circuit efficiency.

The following inductor series from different suppliers have been used with the TPS6112x converters:

List of Inductors

VENDOR	RECOMMENDED INDUCTOR SERIES
Sumida	CDRH5D18
	CDRH6D28
Würth Elektronik	7447789__
	7447779__
Coiltronics	DR73
	DR74
TDK	SLF 7032
EPCOS	B82462G

Capacitor Selection

Input Capacitor

At least a 10-μF input capacitor is recommended to improve transient behavior of the regulator and EMI behavior of the total power supply circuit. A ceramic capacitor or a tantalum capacitor with a 100-nF ceramic capacitor in parallel, placed close to the IC, is recommended.

Output Capacitor DC/DC Converter

The major parameter necessary to define the output capacitor is the maximum allowed output voltage ripple of the converter. This ripple is determined by two parameters of the capacitor, the capacitance and the ESR. It is possible to calculate the minimum capacitance needed for the defined ripple, supposing that the ESR is zero, by using Equation 7:

$$C_{\min} = \frac{I_{\text{OUT}} \times (V_{\text{OUT}} - V_{\text{BAT}})}{f \times \Delta V \times V_{\text{OUT}}} \tag{7}$$

Parameter f is the switching frequency and ΔV is the maximum allowed ripple.

With a chosen ripple voltage of 10 mV, a minimum capacitance of 22 μF is needed. The total ripple is larger due to the ESR of the output capacitor. This additional component of the ripple can be calculated using Equation 8:

$$\Delta V_{\text{ESR}} = I_{\text{OUT}} \times R_{\text{ESR}} \tag{8}$$

An additional ripple of 20 mV is the result of using a tantalum capacitor with a low ESR of 80 mΩ. The total ripple is the sum of the ripple caused by the capacitance and the ripple caused by the ESR of the capacitor. In this example, the total ripple is 30 mV. Additional ripple is caused by load transients. This means that the output capacitance needs to be larger than calculated above to meet the total ripple requirements. The output capacitor has to completely supply the load during the charging phase of the inductor. A reasonable value of the output capacitance depends on the speed of the load transients and the load current during the load change. In typical applications a 100 μF capacitance is recommended. For economical reasons this usually is a tantalum capacitor. Because of this the control loop has been optimized for using output capacitors with an ESR of above 30 mΩ. The minimum value for the output capacitor is 22 μF.

Small Signal Stability

When using output capacitors with lower ESR, like ceramics, it is recommended to use the adjustable voltage version. The missing ESR can be easily compensated there in the feedback divider. Typically a capacitor in the range of 10 pF in parallel with R3 helps to obtain small signal stability, with the lowest ESR output capacitors. For more detailed analysis the small signal transfer function of the error amplifier and regulator, which is given in Equation 9, can be used.

$$A_{\text{REG}} = \frac{d}{V_{\text{FB}}} = \frac{10 \times (R3 + R6)}{R6 \times (1 + i \times \omega \times 1.6 \mu\text{s})} \tag{9}$$

Output Capacitor LDO

To ensure stable output regulation, it is required to use an output capacitor at the LDO output. Ceramic capacitors in the range from 1 μF up to 4.7 μF is recommended. At 4.7 μF and above it is recommended to use standard ESR tantalum. There is no maximum capacitance value.

DETAILED DESCRIPTION

Controller Circuit

The controller circuit of the device is based on a fixed frequency multiple feedforward controller topology. Input voltage, output voltage, and voltage drop on the NMOS switch are monitored and forwarded to the regulator. So changes in the operating conditions of the converter directly affect the duty cycle and must not take the indirect and slow way through the control loop and the error amplifier. The control loop, determined by the error amplifier, only has to handle small signal errors. The input for it is the feedback voltage on the FB pin or, at fixed output voltage versions, the voltage on the internal resistor divider. It is compared with the internal reference voltage to generate an accurate and stable output voltage.

The peak current of the NMOS switch is also sensed to limit the maximum current flowing through the switch and the inductor. The typical peak current limit is set to 1300 mA. An internal temperature sensor prevents the device from getting overheated in case of excessive power dissipation.

Synchronous Rectifier

The device integrates an N-channel and a P-channel MOSFET transistor to realize a synchronous rectifier. Because the commonly used discrete Schottky rectifier is replaced with a low RDS(ON) PMOS switch, the power conversion efficiency reaches 95%. To avoid ground shift due to the high currents in the NMOS switch, two separate ground pins are used. The reference for all control functions is the GND pin. The source of the NMOS switch is connected to PGND. Both grounds must be connected on the PCB at only one point close to the GND pin. A special circuit is applied to disconnect the load from the input during shutdown of the converter. In conventional synchronous rectifier circuits, the backgate diode of the high-side PMOS is forward biased in shutdown and allows current flowing from the battery to the output. This device however uses a special circuit which takes the cathode of the backgate diode of the high-side PMOS and disconnects it from the source when the regulator is not enabled (EN = low).

The benefit of this feature for the system design engineer is that the battery is not depleted during shutdown of the converter. No additional components have to be added to the design to make sure that the battery is disconnected from the output of the converter.

Power Save Mode

The SKIPEN pin can be used to select different operation modes. To enable the Power save mode, SKIPEN must be set high. Power save mode is used to improve efficiency at light loads. In power save mode, the converter only operates when the output voltage trips below a set threshold voltage. It ramps up the output voltage with several pulses, and goes again into power save mode once the output voltage exceeds the set threshold voltage. The skip mode can be disabled by setting the SKIPEN to GND.

LDO

The built-in LDO can be used to generate a second output voltage derived from the dc/dc converter output, from the battery, or from another power source like an ac adapter or a USB power rail. The LDO is capable of being back biased. This allows the user to just connect the outputs of dc/dc converter and LDO. So the device is able to supply the load via dc/dc converter when the energy comes from the battery and efficiency is most important and from another external power source via the LDO when lower efficiency is not critical. The LDO must be disabled if the LDOIN voltage drops below LDOOUT to block reverse current flowing. The status of the dc/dc stage (enabled or disabled) does not matter.

Device Enable

The device is put into operation when EN is set high. It is put into a shutdown mode when EN is set to GND. In shutdown mode, the regulator stops switching, all internal control circuitry including the low-battery comparator is switched off, and the load is isolated from the input (as described in the Synchronous Rectifier Section). This also means that the output voltage can drop below the input voltage during shutdown.

DETAILED DESCRIPTION (continued)

Undervoltage Lockout

An undervoltage lockout function prevents device start-up if the supply voltage on VBAT is lower than approximately 1.6 V. When in operation and the battery is being discharged, the device automatically enters the shutdown mode if the voltage on VBAT drops below approximately 1.6 V. This undervoltage lockout function is implemented in order to prevent the malfunctioning of the converter.

Softstart

During start-up of the converter, the duty cycle and the peak current are limited in order to avoid high peak currents drawn from the battery. When the boost section is enabled, the internal startup cycle starts with the first step, the precharge phase. During precharge, the rectifying switch is turned on until the output capacitor is charged to a value close to the input voltage. The rectifying switch current is limited in that phase. This also limits the output current under short-circuit conditions at the output. After charging the output capacitor to the input voltage the device starts switching. Until the output voltage is reached, the boost switch current limit is set to 40% of its nominal value to avoid high peak currents at the battery during startup. When the output voltage is reached, the regulator takes control and the switch current limit is set back to 100%.

LDO Enable

The LDO can be separately enabled and disabled by using the LDOEN pin in the same way as the EN pin at the dc/dc converter stage described above. This is completely independent of the status of the EN pin. The voltage levels of the logic signals which need to be applied at LDOEN are related to LDOIN.

Power Good

The PGOOD pin stays high impedance when the dc/dc converter delivers an output voltage within a defined voltage window. So it can be used to enable any connected circuitry such as cascaded converters (LDO) or to reset microprocessor circuits.

Low Battery Detector Circuit—LBI/LBO

The low-battery detector circuit is typically used to supervise the battery voltage and to generate an error flag when the battery voltage drops below a user-set threshold voltage. The function is active only when the device is enabled. When the device is disabled, the LBO pin is high-impedance. The switching threshold is 500 mV at LBI. During normal operation, LBO stays at high impedance when the voltage, applied at LBI, is above the threshold. It is active low when the voltage at LBI goes below 500 mV.

The battery voltage, at which the detection circuit switches, can be programmed with a resistive divider connected to the LBI pin. The resistive divider scales down the battery voltage to a voltage level of 500 mV, which is then compared to the LBI threshold voltage. The LBI pin has a built-in hysteresis of 10 mV. See the application section for more details about the programming of the LBI threshold. If the low-battery detection circuit is not used, the LBI pin should be connected to GND (or to VBAT) and the LBO pin can be left unconnected. Do not let the LBI pin float.

Low-EMI Switch

The device integrates a circuit that removes the ringing that typically appears on the SW node when the converter enters discontinuous current mode. In this case, the current through the inductor ramps to zero and the rectifying PMOS switch is turned off to prevent a reverse current flowing from the output capacitors back to the battery. Due to the remaining energy that is stored in parasitic components of the semiconductor and the inductor, a ringing on the SW pin is induced. The integrated antiringing switch clamps this voltage to VBAT and therefore dampens ringing.

LAYOUT CONSIDERATIONS

As for all switching power supplies, the layout is an important step in the design, especially at high peak currents and high switching frequencies. If the layout is not carefully done, the regulator could show stability problems as well as EMI problems. Therefore, use wide and short traces for the main current path and for the power ground tracks. The input capacitor, output capacitor, and the inductor should be placed as close as possible to the IC. Use a common ground node for power ground and a different one for control ground to minimize the effects of ground noise. Connect these ground nodes at any place close to one of the ground pins of the IC.

The feedback divider should be placed as close as possible to the control ground pin of the IC. To lay out the control ground, it is recommended to use short traces as well, separated from the power ground traces. This avoids ground shift problems, which can occur due to superimposition of power ground current and control ground current.

APPLICATION EXAMPLES

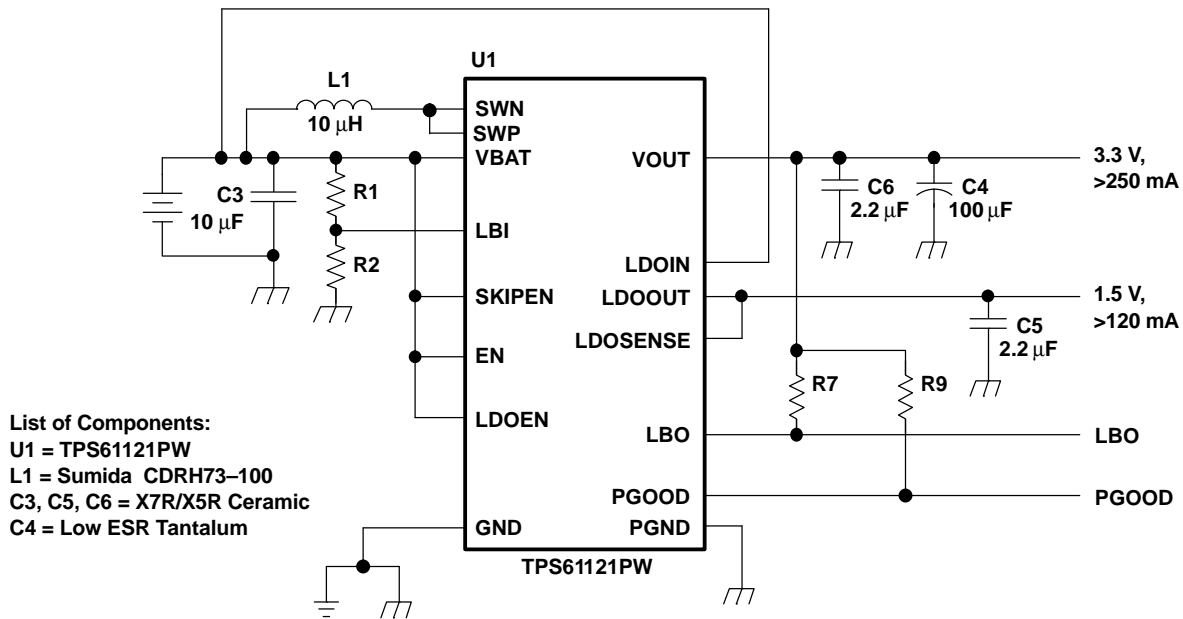

Figure 25. Solution for Maximum Output Power

APPLICATION INFORMATION

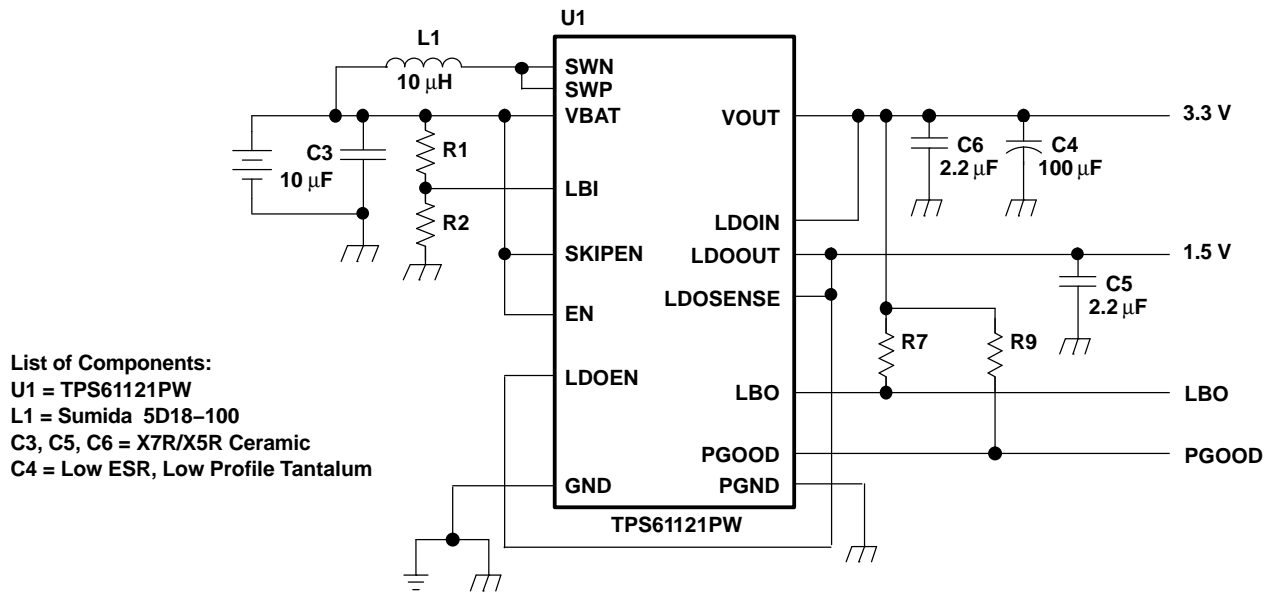

Figure 26. Low Profile Solution, Maximum Height 1,8 mm

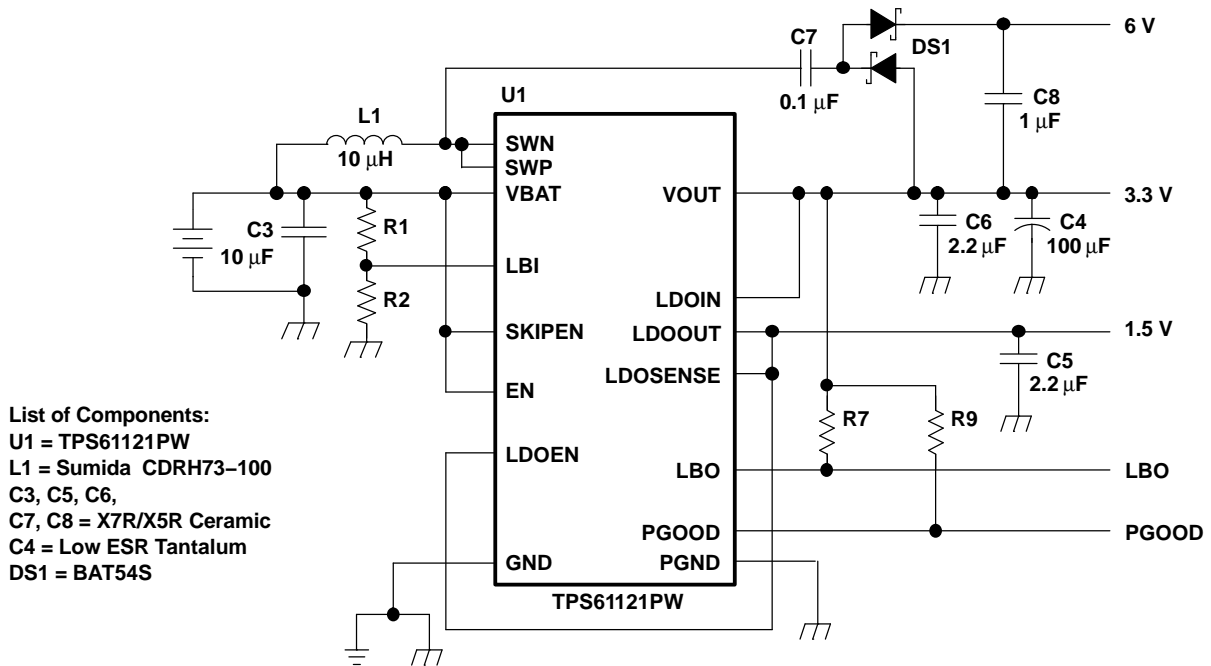

Figure 27. Dual Power Supply With Auxiliary Positive Output Voltage

APPLICATION INFORMATION (continued)

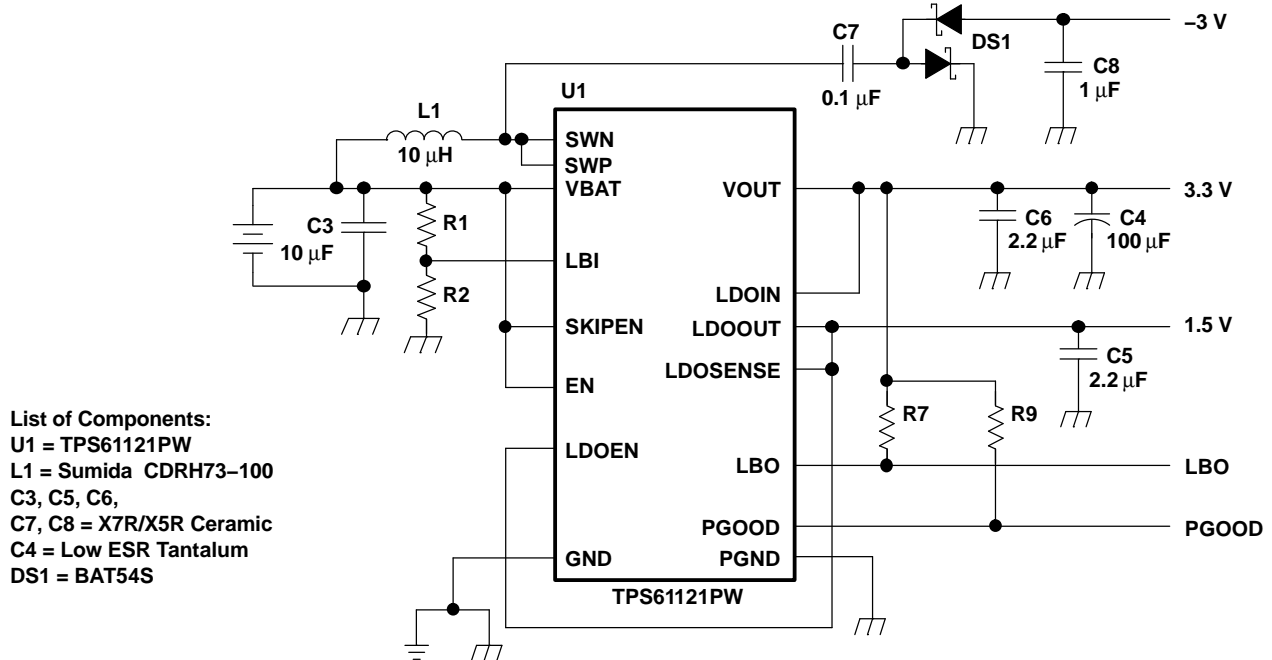

Figure 28. Dual Power Supply With Auxiliary Negative Output Voltage

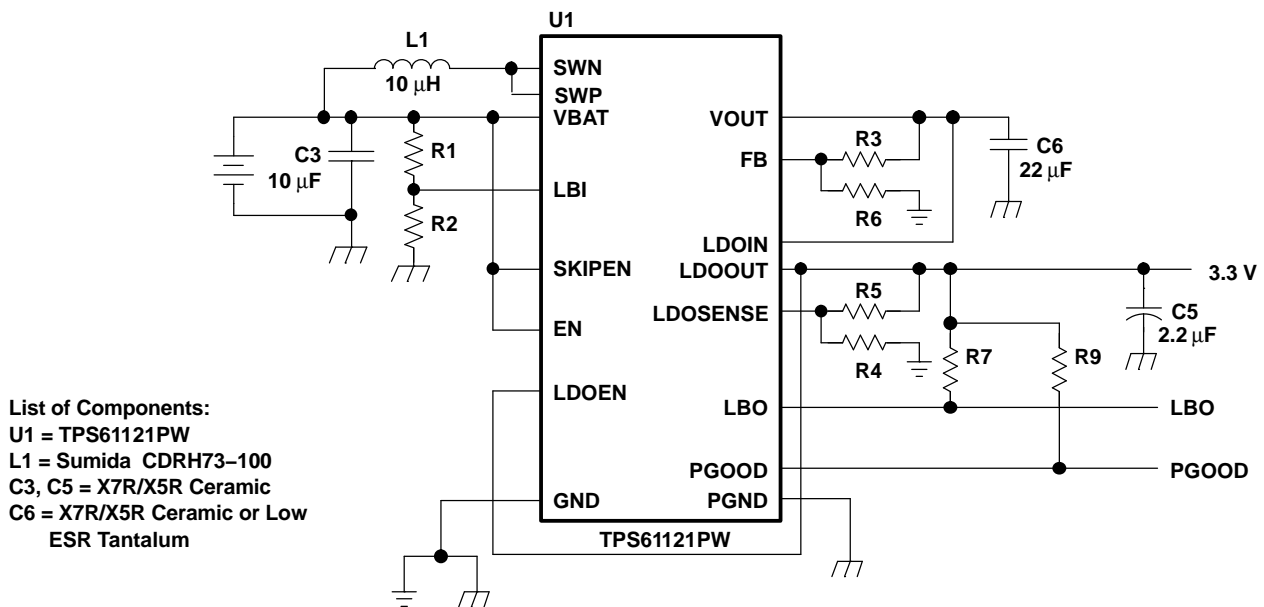

Figure 29. Single Output Using LDO as Filter

APPLICATION INFORMATION (continued)

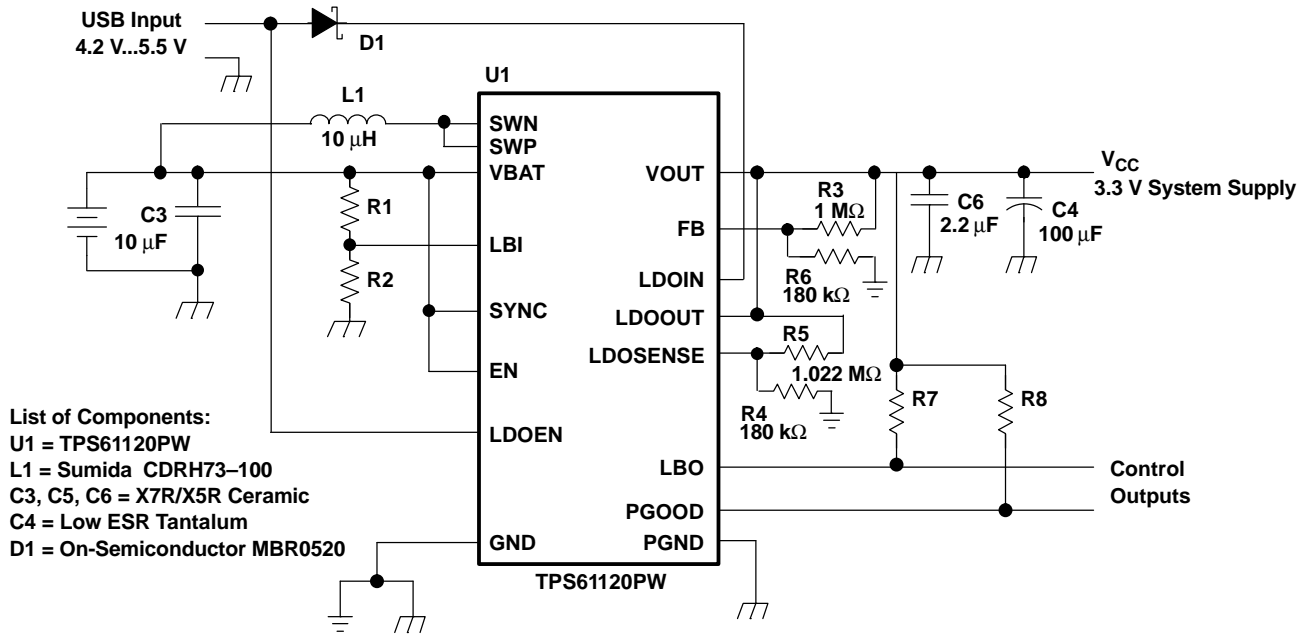

Figure 30. Dual Input Power Supply Solution

THERMAL INFORMATION

Implementation of integrated circuits in low-profile and fine-pitch surface-mount packages typically requires special attention to power dissipation. Many system-dependent issues such as thermal coupling, airflow, added heat sinks and convection surfaces, and the presence of other heat-generating components affect the power-dissipation limits of a given component.

Three basic approaches for enhancing thermal performance are listed below.

- Improving the power dissipation capability of the PCB design
- Improving the thermal coupling of the component to the PCB
- Introducing airflow in the system

The maximum junction temperature (T_J) of the TPS6112x devices is 150 °C. The thermal resistance of the 16-pin TSSOP package (PW) is $R_{\theta JA} = 155$ °C/W. The 16-pin QFN PowerPAD package (RSA) has a thermal resistance of $R_{\theta JA} = 38.1$ °C/W, if the PowerPAD is soldered and the board layout is optimized. Specified regulator operation is assured to a maximum ambient temperature T_A of 85°C. Therefore, the maximum power dissipation is about 420 mW for the TSSOP (PW) package and 1700 mW for the QFN (RSA) package; See Equation 10. More power can be dissipated if the maximum ambient temperature of the application is lower.

$$P_{D(MAX)} = \frac{T_{J(MAX)} - T_A}{R_{\theta JA}} = \frac{150\text{ °C} - 85\text{ °C}}{155\text{ °C/W}} = 420\text{ mW} \quad (10)$$

If designing for a lower junction temperature of 125°C, which is recommended, maximum heat dissipation is lower. Using the above Equation 10 results in 1050 mW power dissipation for the RSA package and 260mW for the PW package.

RSA (S-PQFP-N16)

PLASTIC QUAD FLATPACK

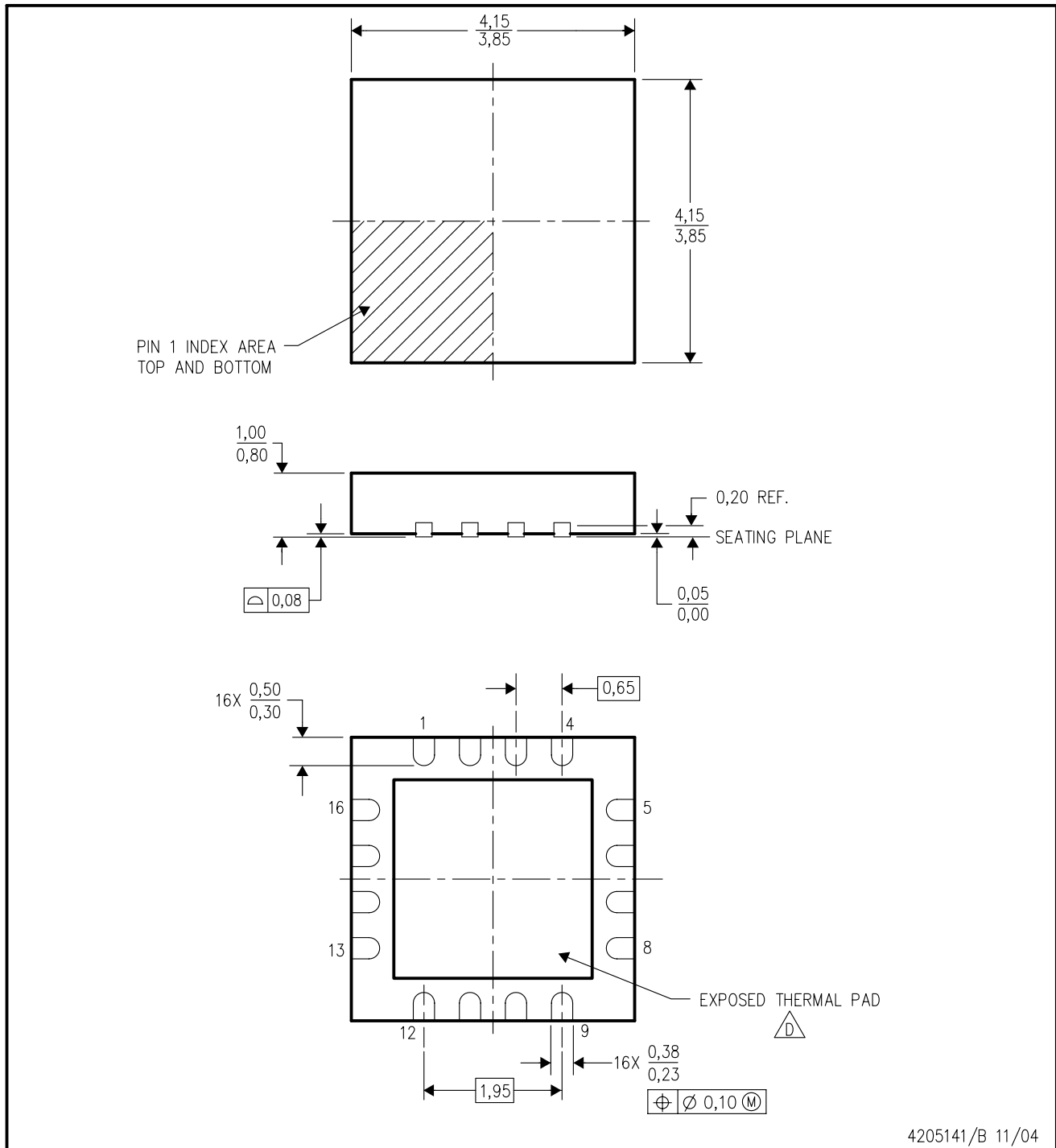

4205141/B 11/04

- NOTES:
- A. All linear dimensions are in millimeters. Dimensioning and tolerancing per ASME Y14.5M-1994.
 - B. This drawing is subject to change without notice.
 - C. Quad Flatpack, No-leads (QFN) package configuration.
 - △ The package thermal pad must be soldered to the board for thermal and mechanical performance. See the Product Data Sheet for details regarding the exposed thermal pad dimensions.
 - E. Falls within JEDEC MO-220.

PW (R-PDSO-G**)

PLASTIC SMALL-OUTLINE PACKAGE

14 PINS SHOWN



4040064/F 01/97

- NOTES: A. All linear dimensions are in millimeters.
 B. This drawing is subject to change without notice.
 C. Body dimensions do not include mold flash or protrusion not to exceed 0,15.
 D. Falls within JEDEC MO-153

IMPORTANT NOTICE

Texas Instruments Incorporated and its subsidiaries (TI) reserve the right to make corrections, modifications, enhancements, improvements, and other changes to its products and services at any time and to discontinue any product or service without notice. Customers should obtain the latest relevant information before placing orders and should verify that such information is current and complete. All products are sold subject to TI's terms and conditions of sale supplied at the time of order acknowledgment.

TI warrants performance of its hardware products to the specifications applicable at the time of sale in accordance with TI's standard warranty. Testing and other quality control techniques are used to the extent TI deems necessary to support this warranty. Except where mandated by government requirements, testing of all parameters of each product is not necessarily performed.

TI assumes no liability for applications assistance or customer product design. Customers are responsible for their products and applications using TI components. To minimize the risks associated with customer products and applications, customers should provide adequate design and operating safeguards.

TI does not warrant or represent that any license, either express or implied, is granted under any TI patent right, copyright, mask work right, or other TI intellectual property right relating to any combination, machine, or process in which TI products or services are used. Information published by TI regarding third-party products or services does not constitute a license from TI to use such products or services or a warranty or endorsement thereof. Use of such information may require a license from a third party under the patents or other intellectual property of the third party, or a license from TI under the patents or other intellectual property of TI.

Reproduction of information in TI data books or data sheets is permissible only if reproduction is without alteration and is accompanied by all associated warranties, conditions, limitations, and notices. Reproduction of this information with alteration is an unfair and deceptive business practice. TI is not responsible or liable for such altered documentation.

Resale of TI products or services with statements different from or beyond the parameters stated by TI for that product or service voids all express and any implied warranties for the associated TI product or service and is an unfair and deceptive business practice. TI is not responsible or liable for any such statements.

Following are URLs where you can obtain information on other Texas Instruments products and application solutions:

Products		Applications	
Amplifiers	amplifier.ti.com	Audio	www.ti.com/audio
Data Converters	dataconverter.ti.com	Automotive	www.ti.com/automotive
DSP	dsp.ti.com	Broadband	www.ti.com/broadband
Interface	interface.ti.com	Digital Control	www.ti.com/digitalcontrol
Logic	logic.ti.com	Military	www.ti.com/military
Power Mgmt	power.ti.com	Optical Networking	www.ti.com/opticalnetwork
Microcontrollers	microcontroller.ti.com	Security	www.ti.com/security
		Telephony	www.ti.com/telephony
		Video & Imaging	www.ti.com/video
		Wireless	www.ti.com/wireless

Mailing Address: Texas Instruments
Post Office Box 655303 Dallas, Texas 75265