

SYNCHRONOUS SEPIC / FLYBACK CONVERTER WITH 1.1A SWITCH AND INTEGRATED LDO

FEATURES

- Synchronous, Up To 90% Efficient, SEPIC Converter With 300-mA Output Current From 2.5-V Input
- Integrated 200-mA Reverse Voltage Protected LDO for DC/DC Output Voltage Post Regulation or Second Output Voltage
- Dual Input or Dual Output Mode
- Available in a 16 pin QFN 4x4 or in a TSSOP-16 Package
- 40- μ A (Typical) Total Device Quiescent Current
- Input Voltage Range: 1.8-V to 5.5-V
- Adjustable Output Voltage up to 5.5-V, Fixed Output Voltage Options
- Power Save Mode for Improved Efficiency at Low Output Power
- High Efficient Li-Ion to 3.3-V Conversion
- Low Battery Comparator
- Power Good Output
- Low EMI-Converter (Integrated Antiringing Switch)
- Load Disconnect During Shutdown
- Overtemperature Protection

APPLICATIONS

- All Single Cell Li, Dual or Triple Cell Battery or USB Powered Products as MP-3 Player, PDAs, and Other Portable Equipment

DESCRIPTION

The TPS6113x devices provide a complete power supply solution for products powered by either a one-cell Li-Ion or Li-Polymer or a two up to four-cell Alkaline, NiCd or NiMH batteries. The device can generate two regulated output voltages that are either adjusted by an external resistor divider or fixed internally on the chip. It also provides a simple and efficient buck-boost solution for generating 3.3 V out of a one-cell Li-Ion or Li-Polymer battery at a maximum output current of at least 300 mA with supply voltages down to 1.8 V. The implemented SEPIC converter is based on a fixed frequency, pulse-width-modulation (PWM) controller using a synchronous rectifier to obtain maximum efficiency. The maximum peak current in the SEPIC switch is limited to a value of 1600 mA.

The converter can be disabled to minimize battery drain. During shutdown, the load is completely disconnected from the battery. A low-EMI mode is implemented to reduce ringing and in effect lower radiated electromagnetic energy when the converter enters the discontinuous conduction mode. A power good output at the SEPIC stage provides additional control of any connected circuits like cascaded power supply stages or microprocessors.

The built-in LDO can be used for a second output voltage derived either from the SEPIC output or directly from the battery. The output voltage of this LDO can be programmed by an external resistor divider or is fixed internally on the chip. The LDO can be enabled separately i.e., using the power good of the SEPIC stage.

The device is packaged in a 16-pin QFN 4 x 4 mm (16RSA) or in a 16-pin TSSOP (16PW) package.

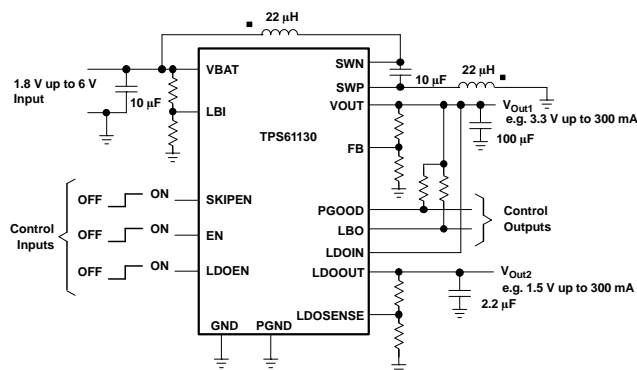

Please be aware that an important notice concerning availability, standard warranty, and use in critical applications of Texas Instruments semiconductor products and disclaimers thereto appears at the end of this data sheet.

AVAILABLE OUTPUT VOLTAGE OPTIONS (1)

T _A	OUTPUT VOLTAGE DC/DC	OUTPUT VOLTAGE LDO	PACKAGE	PART NUMBER (2)
40°C to 85°C	Adjustable	Adjustable	16-Pin TSSOP	TPS61130PW
	3.3 V	3.3 V	16-Pin TSSOP	TPS61131PW
	3.3 V	1.5 V	16-Pin TSSOP	TPS61132PW
	Adjustable	Adjustable	16-Pin QFN 4x4mm	TPS61130RSA
	3.3 V	1.5 V	16-Pin QFN 4x4mm	TPS61132RSA

- (1) Contact the factory to check availability of other fixed output voltage versions.
- (2) The packages are available taped and reeled. Add R suffix to device type (e.g., TPS61130PWR or TPS61130RSAR) to order quantities of 2000 devices per reel for the TSSOP (PW) package and 3000 devices per reel for the QFN (RSA) package.

ABSOLUTE MAXIMUM RATINGS

over operating free-air temperature range (unless otherwise noted) (1)

	TPS61130 TPS61131 TPS61132
Input voltage range on FB	-0.3 V to 3.6 V
Input voltage range on SWN	-0.3 V to 12 V
Input voltage range on SWP	-7.0 V to 7.0 V
Maximum voltage between SWP and VOUT	-12 V
Input voltage range on SWN, VOUT, LDOIN, LDOOUT, LDOEN, LDOSENSE, PGOOD, LBO, VBAT, LBI, SKIPEN, EN	-0.3 V to 7 V
Operating free air temperature range T _A	-40°C to 85°C
Maximum junction temperature T _J	150°C
Storage temperature range T _{stg}	-65°C to 150°C

- (1) Stresses beyond those listed under "absolute maximum ratings" may cause permanent damage to the device. These are stress ratings only, and functional operation of the device at these or any other conditions beyond those indicated under "recommended operating conditions" is not implied. Exposure to absolute-maximum-rated conditions for extended periods may affect device reliability.

RECOMMENDED OPERATING CONDITIONS

	MIN	NOM	MAX	UNIT
Supply voltage at VBAT, V _I	1.8		6.5	V
DC/DC—inductance, L	10	22		μH
DC/DC—input capacitance, C _i		10		μF
DC/DC—output capacitance, C _o	22	100		μF
LDO—input capacitance, C _i		1		μF
LDO—output capacitance, C _o	1	2.2		μF
Operating virtual junction temperature, T _J	-40		125	°C

ELECTRICAL CHARACTERISTICS

over recommended free-air temperature range and over recommended input voltage range (typical at an ambient temperature range of 25°C) (unless otherwise noted)

DC/DC STAGE								
PARAMETER	TEST CONDITIONS		MIN	TYP	MAX	UNIT		
V_I	Input voltage range		1.8		6.5	V		
V_O	Adjustable output voltage range (TPS61130)		2.5		5.5	V		
V_{ref}	Reference voltage		485	500	515	mV		
f	Oscillator frequency		400	500	600	kHz		
I_{SW}	Switch current limit		VOUT= 3.3 V		1100	1300	1600	mA
	Startup current limit				0.4 x I_{SW}		mA	
	SWN switch on resistance		VOUT= 3.3 V		200	350	mΩ	
	SWP switch on resistance		VOUT= 3.3 V		250	500	mΩ	
Total accuracy (including line and load regulation)					3		%	
DC/DC quiescent current	into VBAT	$I_O = 0$ mA, $V_{EN} = V_{BAT} = 1.8$ V, $V_{OUT} = 3.3$ V, $ENLDO = 0$ V		10	25	μA		
	into VOUT	$I_O = 0$ mA, $V_{EN} = V_{BAT} = 1.8$ V, $V_{OUT} = 3.3$ V, $ENLDO = 0$ V		10	25	μA		
DC/DC shutdown current		$V_{EN} = 0$ V		0.2	1	μA		
LDO STAGE								
PARAMETER	TEST CONDITIONS		MIN	TYP	MAX	UNIT		
$V_{I(LDO)}$	Input voltage range		1.8		7	V		
$V_{O(LDO)}$	Adjustable output voltage range (TPS61130)		0.9		5.5	V		
$I_{O(max)}$	Output current		200	320		mA		
LDO short circuit current limit					500	mA		
Minimum voltage drop		$I_O = 200$ mA			300	mV		
Total accuracy (including line and load regulation)		$I_O \geq 1$ mA			±3%			
Line regulation		LDOIN change from 1.8 V to 2.6 V at 100 mA, LDOOUT = 1.5 V			0.6%			
Load regulation		Load change from 10% to 90%, LDOIN = 3.3 V			0.6%			
LDO quiescent current		LDOIN = 7 V, VBAT = 1.8 V, EN = VBAT		20	30	μA		
LDO shutdown current		LDOEN = 0 V, LDOIN = 7 V		0.1	1	μA		

CONTROL STAGE						
PARAMETER	TEST CONDITIONS		MIN	TYP	MAX	UNIT
V_{IL}	LBI voltage threshold	V_{LBI} voltage decreasing	490	500	510	mV
	LBI input hysteresis			10		mV
	LBI input current	EN = VBAT or GND		0.01	0.1	μ A
	LBO output low voltage	$V_O = 3.3$ V, $I_{OI} = 100$ μ A		0.04	0.4	V
	LBO output low current			100		μ A
	LBO output leakage current	$V_{LBO} = 7$ V		0.01	0.1	μ A
V_{IL}	EN, SKIPEN input low voltage				$0.2 \times V_{BAT}$	V
V_{IH}	EN, SKIPEN input high voltage		$0.8 \times V_{BAT}$			V
V_{IL}	LDOEN input low voltage				$0.2 \times V_{LDOIN}$	V
V_{IH}	LDOEN input high voltage		$0.8 \times V_{LDOIN}$			V
	EN, SKIPEN input current	Clamped on GND or VBAT		0.01	0.1	μ A
	Power-Good threshold	$V_O = 3.3$ V	$0.9xV_o$	$0.92xV_o$	$0.95xV_o$	V
	Power-Good delay			30		μ s
	Power-Good output low voltage	$V_O = 3.3$ V, $I_{OI} = 100$ μ A		0.04	0.4	V
	Power-Good output low current			100		μ A
	Power-Good output leakage current	$V_{PG} = 7$ V		0.01	0.1	μ A
	Over-Temperature protection			140		$^{\circ}$ C
	Over-Temperature hysteresis			20		$^{\circ}$ C

PIN ASSIGNMENTS

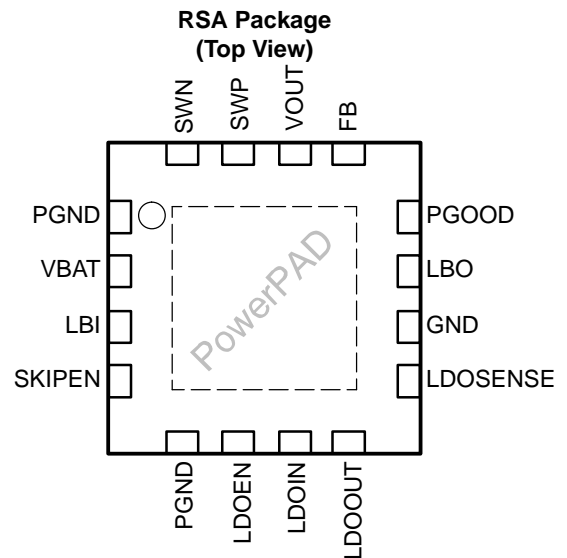
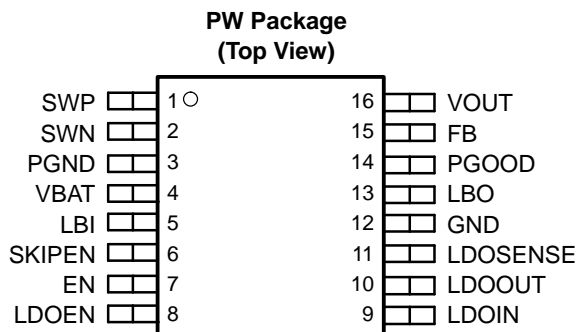

Terminal Functions

NAME	TERMINAL		I/O	Description
	NO.			
	PW	RSA		
EN	7	5	I	DC/DC-enable input. (1/VBAT enabled, 0/GND disabled)
FB	15	13	I	DC/DC voltage feedback of adjustable versions
GND	12	10	I/O	Control/logic ground
LBI	5	3	I	Low battery comparator input (comparator enabled with EN)
LBO	13	11	O	Low battery comparator output (open drain)
LDOEN	8	6	I	LDO-enable input (1/LDOIN enabled, 0/GND disabled)
LDOOUT	10	8	O	LDO output
LDOIN	9	7	I	LDO input
LDOSENSE	11	9	I	LDO feedback for voltage adjustment, must be connected to LDOOUT at fixed output voltage versions
SWP	1	15	I	DC/DC rectifying switch input
PGND	3	1	I/O	Power ground
PGOOD	14	12	O	DC/DC output power good (1 : good, 0 : failure) (open drain)
SKIPEN	6	4	I	Enable/disable power save mode (1/VBAT enabled, 0/GND disabled)
SWN	2	16	I	DC/DC switch input
VBAT	4	2	I	Supply pin
VOUT	16	14	O	DC/DC output

FUNCTIONAL BLOCK DIAGRAM

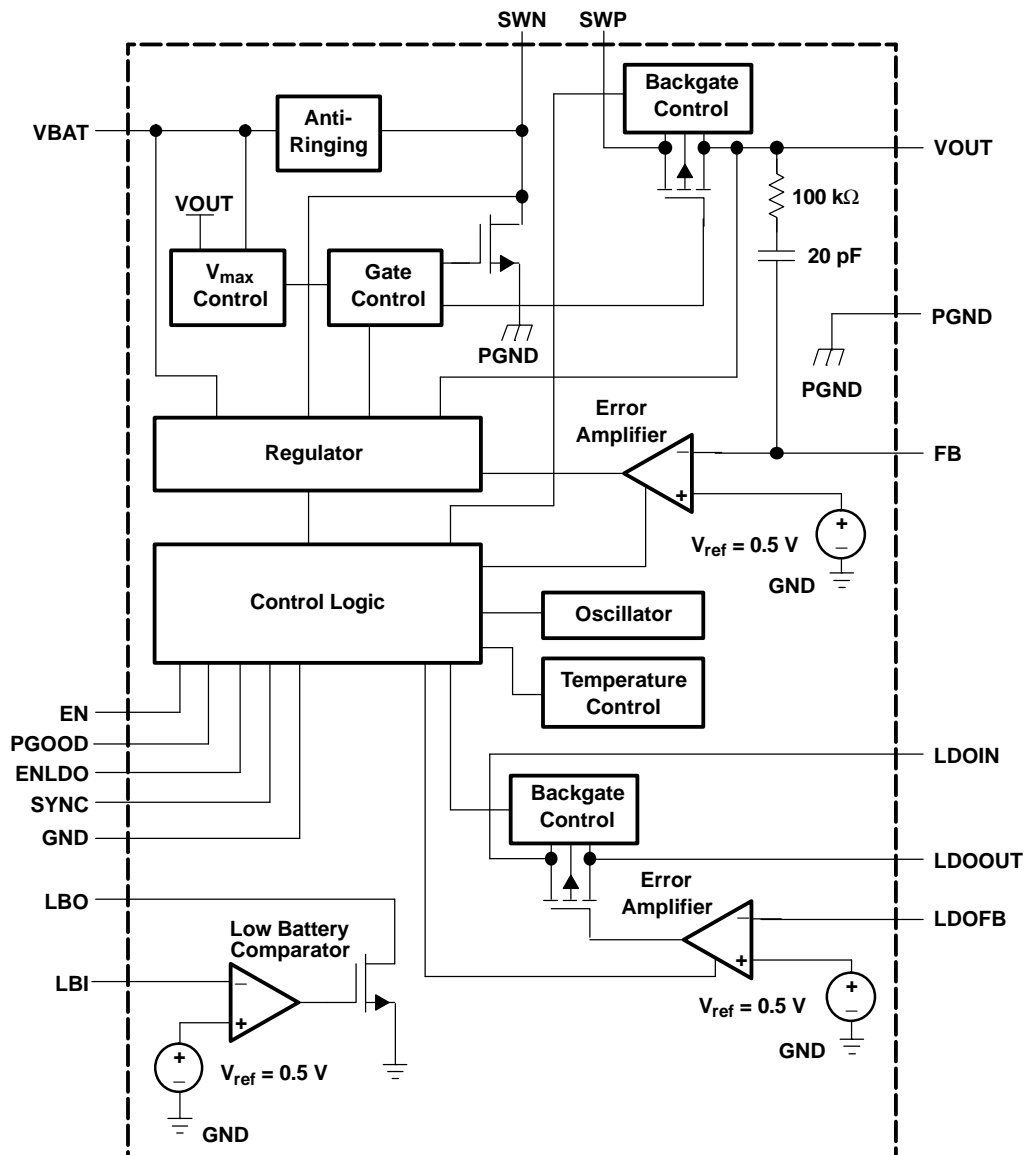

PARAMETER MEASUREMENT INFORMATION

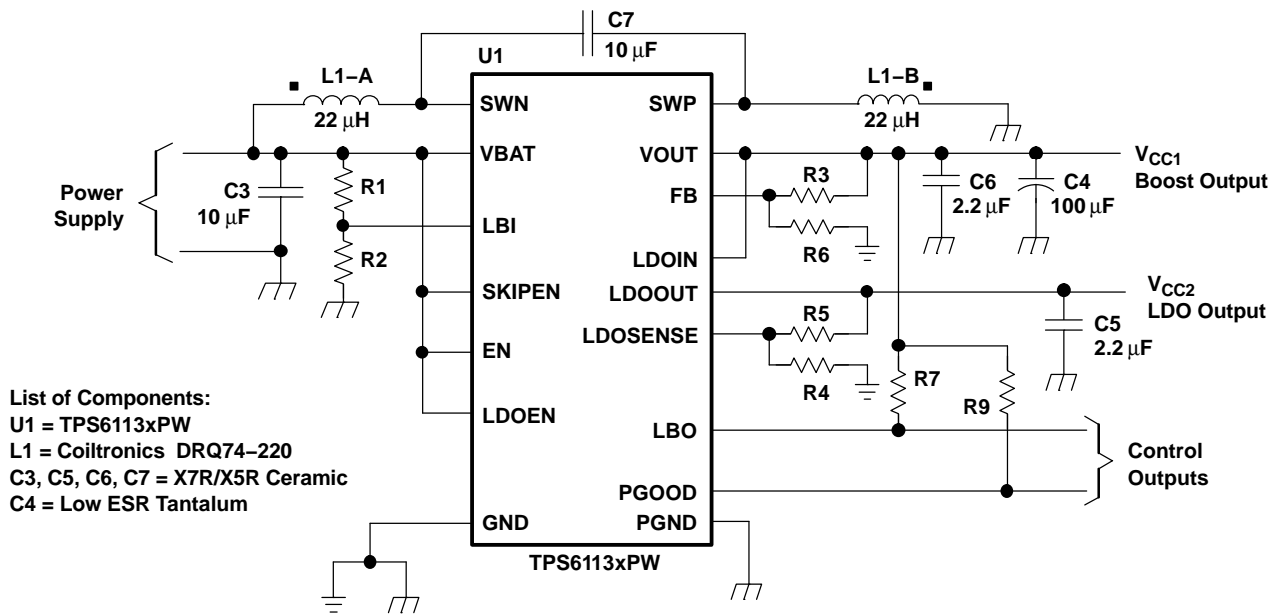

TYPICAL CHARACTERISTICS

Table of Graphs

SEPIC Converter		Figure
Maximum output current	vs Input voltage (TPS61130) ($V_O = 3.3\text{ V}, 5.0\text{ V}, 2.5\text{ V}$)	1, 2
Efficiency	vs Output current (TPS61130) ($V_O = 2.5\text{ V}, V_I = 1.8\text{ V}$)	3
	vs Output current (TPS61132) ($V_O = 3.3\text{ V}, V_I = 1.8\text{ V}, 3.8\text{ V}$)	4
	vs Output current (TPS61130) ($V_O = 5.0\text{ V}, V_I = 3.6\text{ V}, 6.0\text{ V}$)	5
	vs Input voltage (TPS61132)	6
Output voltage	vs Output current (TPS61132)	7
No-load supply current into VBAT	vs Input voltage (TPS61132)	8
No-load supply current into VOUT	vs Input voltage (TPS61132)	9
Waveforms	Output voltage in continuous mode (TPS61132)	10
	Output voltage in power save mode (TPS61132)	11
	Load transient response (TPS61132)	12
	Line transient response (TPS61132)	13
	Start-up after enable (TPS61132)	14
LDO		
Maximum output current	vs Input voltage ($V_O = 2.5\text{ V}, 3.3\text{ V}$)	15
	vs Input voltage ($V_O = 1.5\text{ V}, 1.8\text{ V}$)	16
Output voltage	vs Output current (TPS61131)	17
Dropout voltage	vs Output current (TPS61131, TPS61132)	18
Supply current into LDOIN	vs LDOIN input voltage (TPS61132)	19
PSRR	vs Frequency (TPS61132)	20
Waveforms	Load transient response	21
	Line transient response	22
	Start-up after enable	23

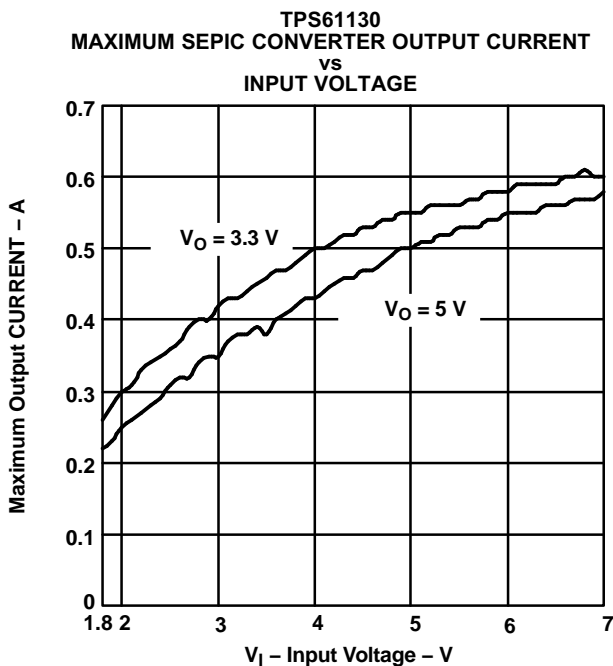

Figure 1.

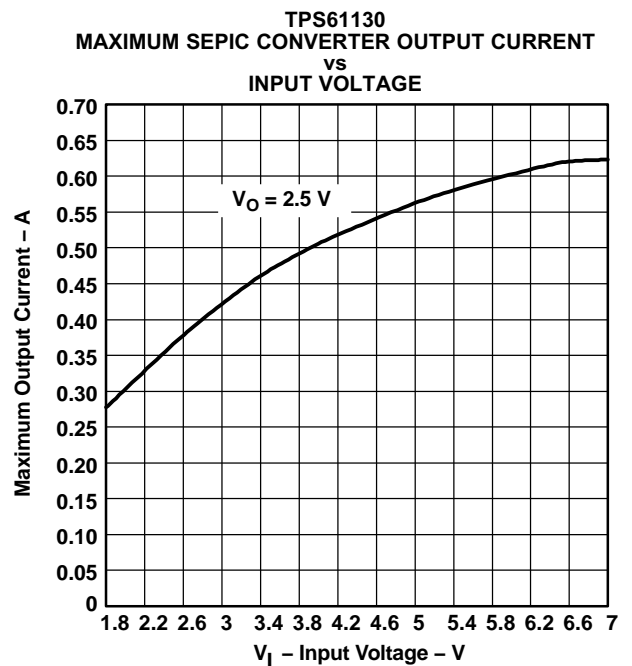

Figure 2.

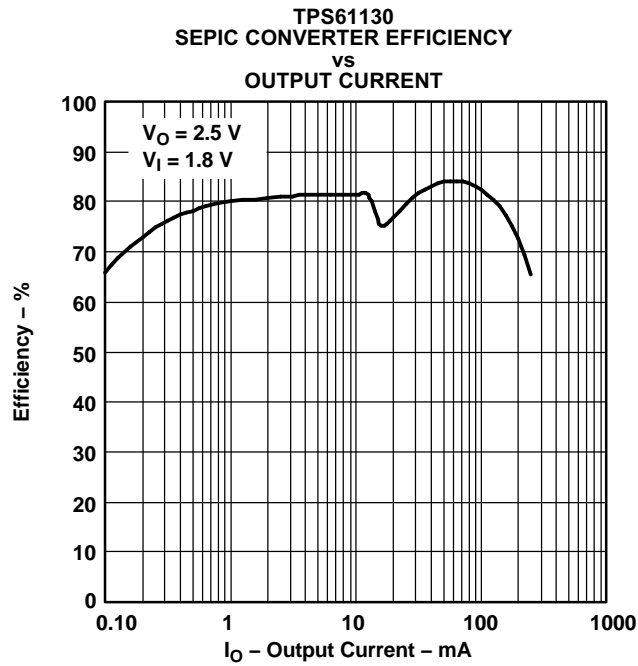

Figure 3.

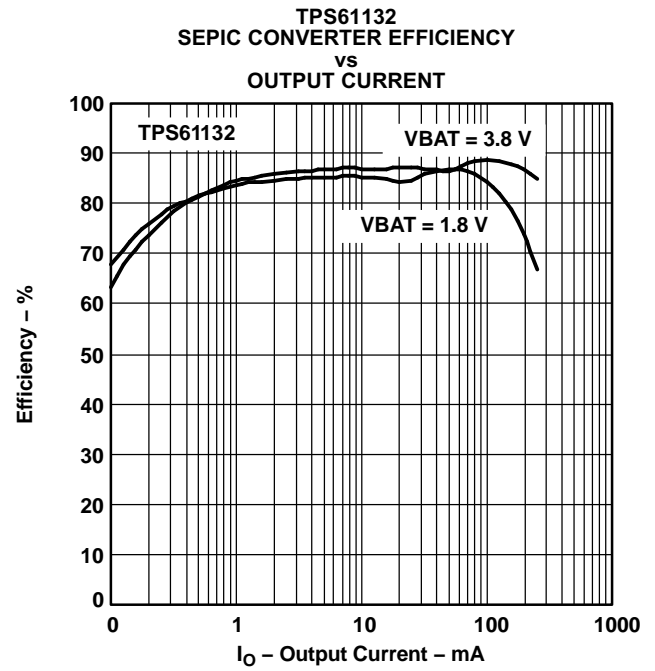

Figure 4.

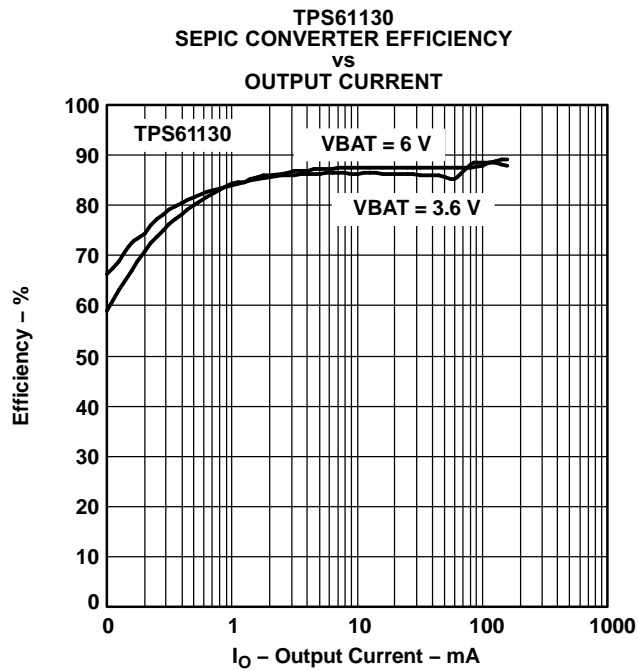

Figure 5.

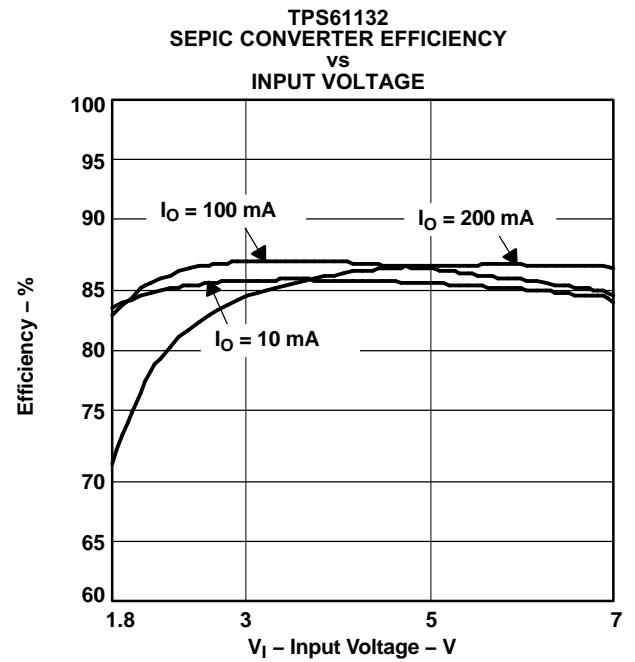

Figure 6.

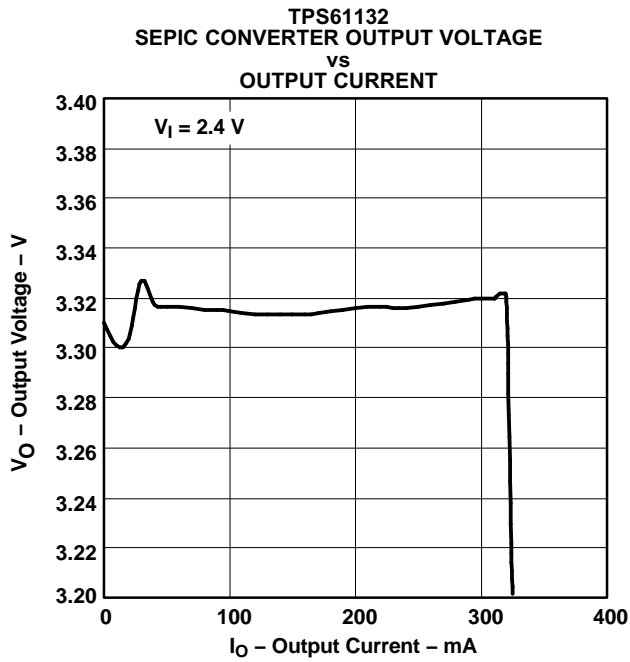

Figure 7.

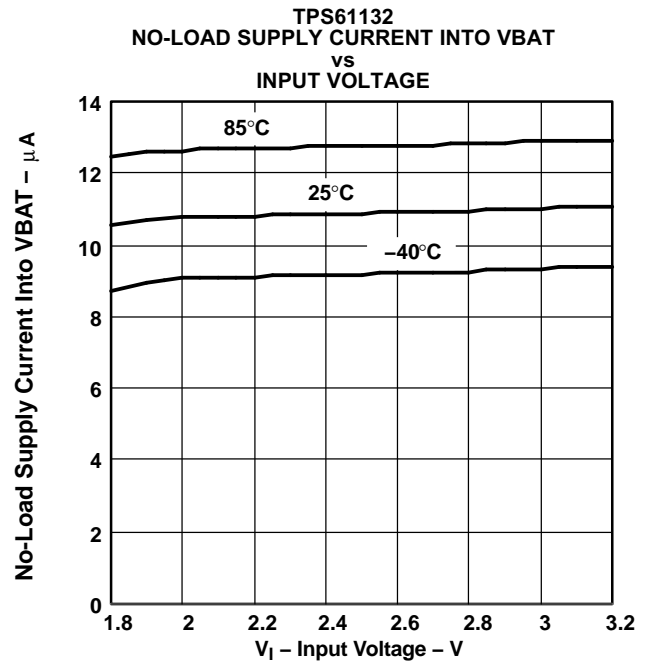

Figure 8.

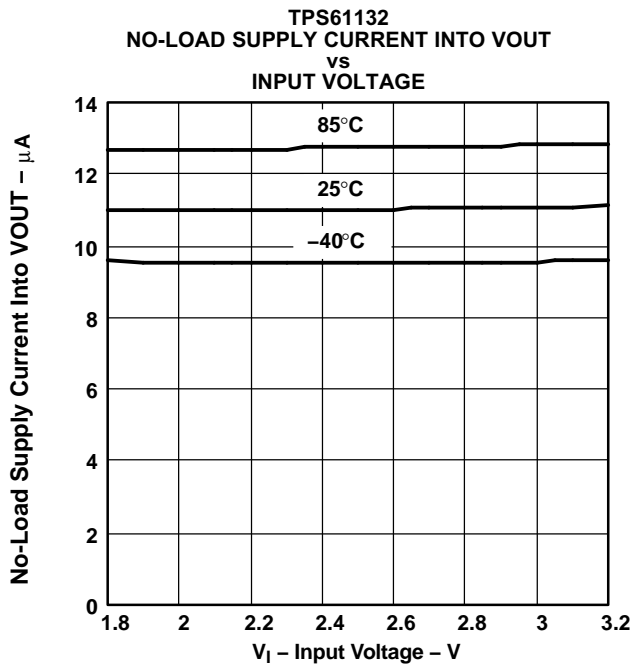

Figure 9.

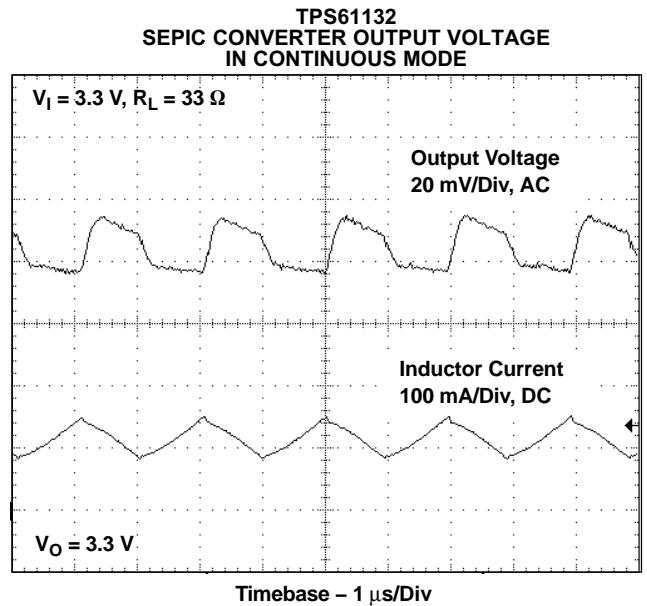
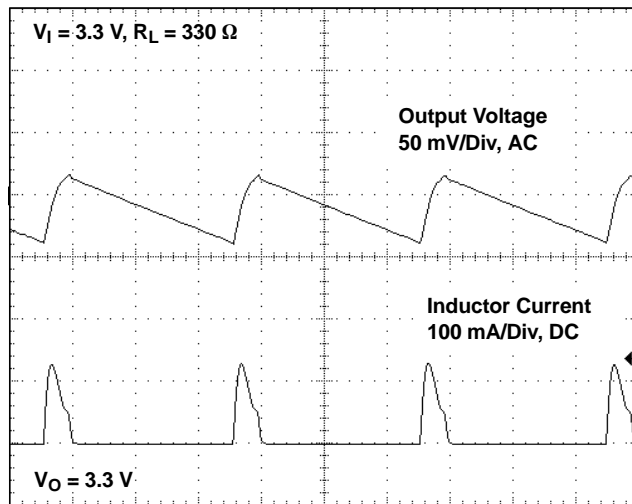

Figure 10.

**TPS61132
SEPIC CONVERTER OUTPUT VOLTAGE
IN POWER SAVE MODE**



Timebase – 200 $\mu\text{s}/\text{Div}$
 Figure 11.

**TPS61132
SEPIC CONVERTER LOAD TRANSIENT RESPONSE**

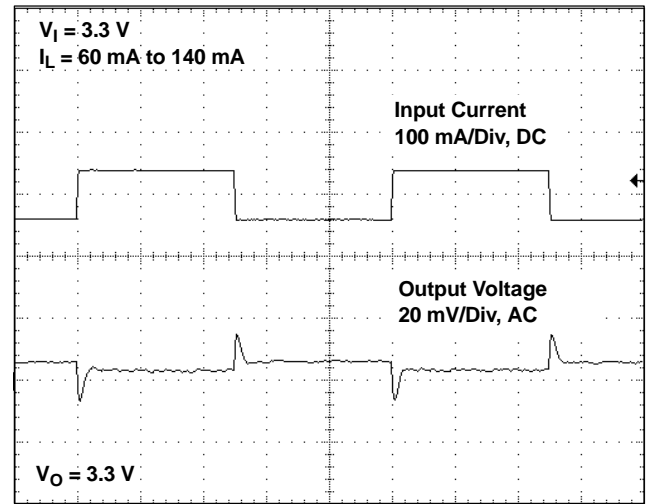

Timebase – 500 $\mu\text{s}/\text{Div}$
 Figure 12.

**TPS61132
SEPIC CONVERTER LINE TRANSIENT RESPONSE**

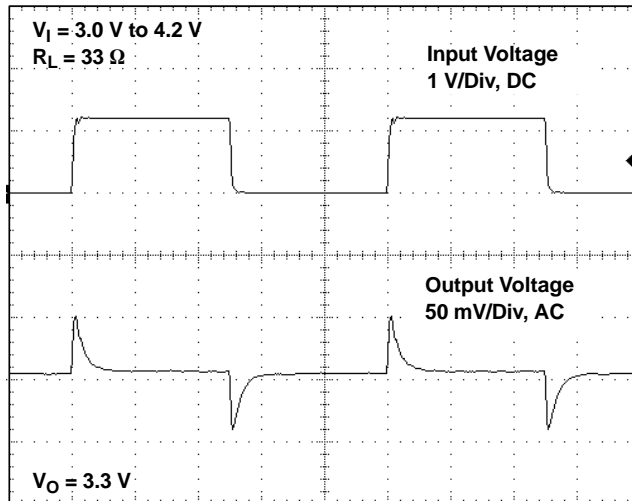

Timebase – 200 $\mu\text{s}/\text{Div}$
 Figure 13.

**TPS61132
SEPIC CONVERTER START-UP AFTER ENABLE**

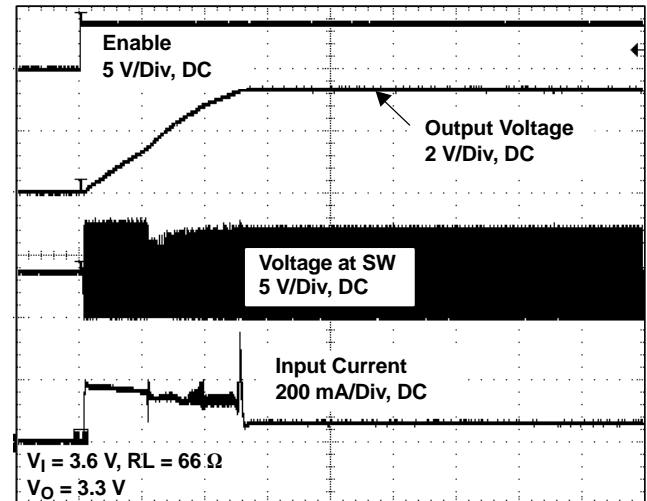

Timebase – 400 $\mu\text{s}/\text{Div}$
 Figure 14.

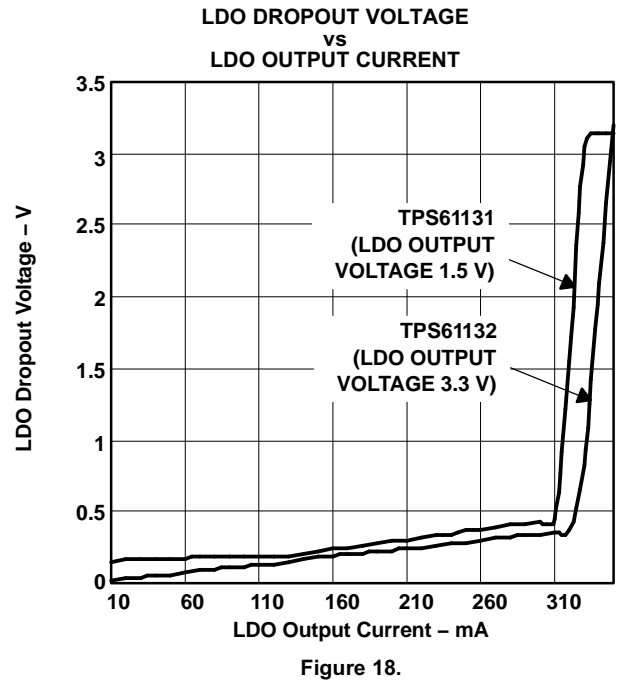
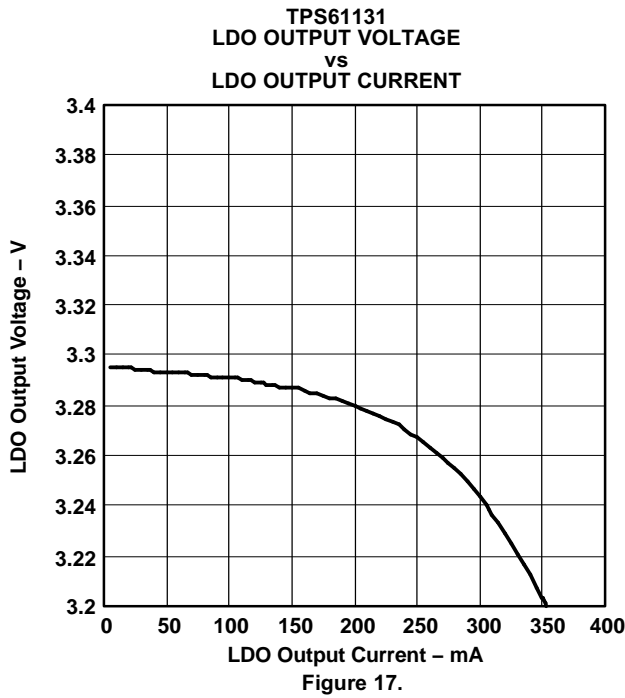
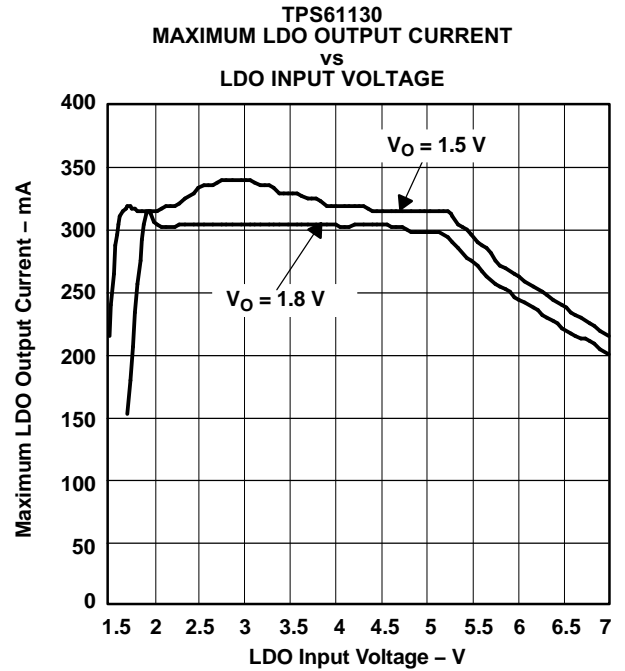
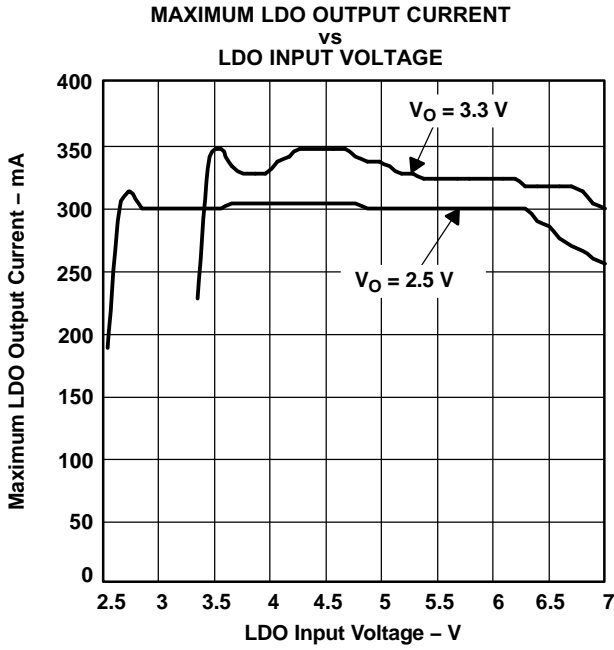

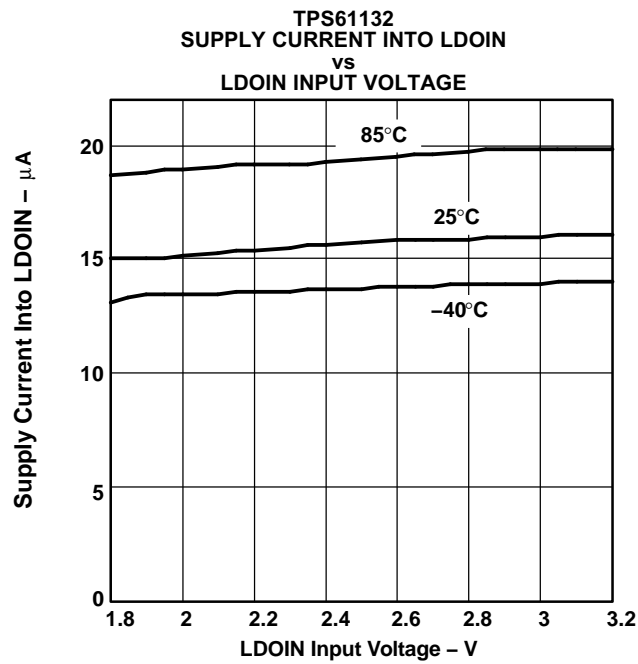

Figure 19.

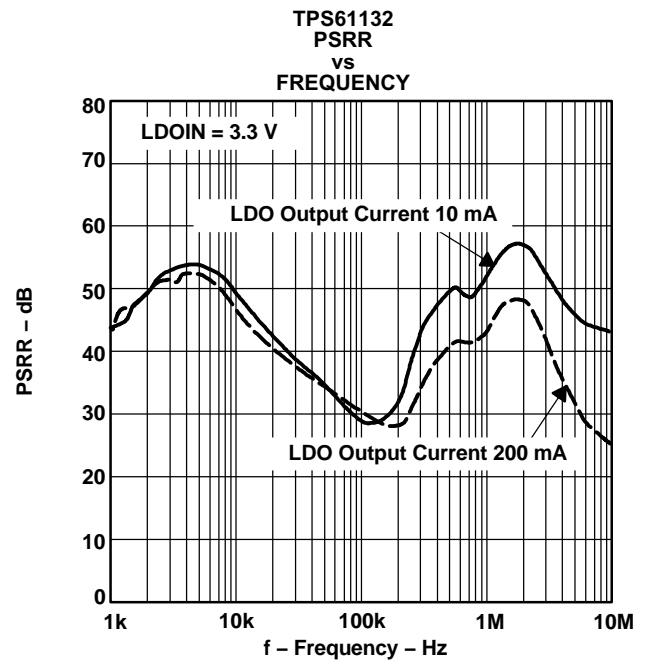
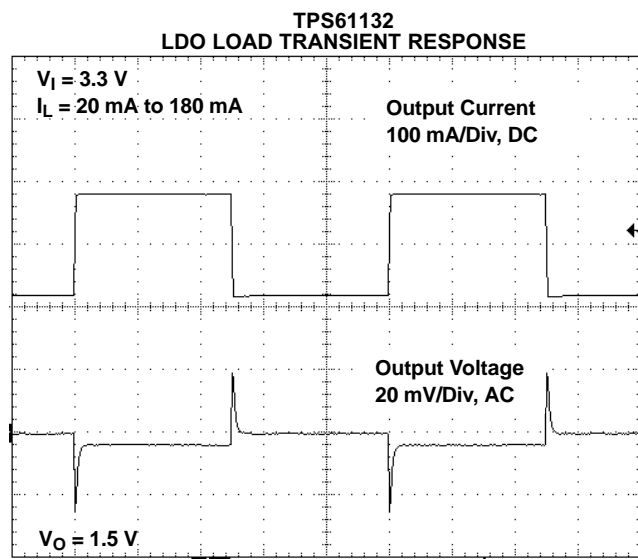
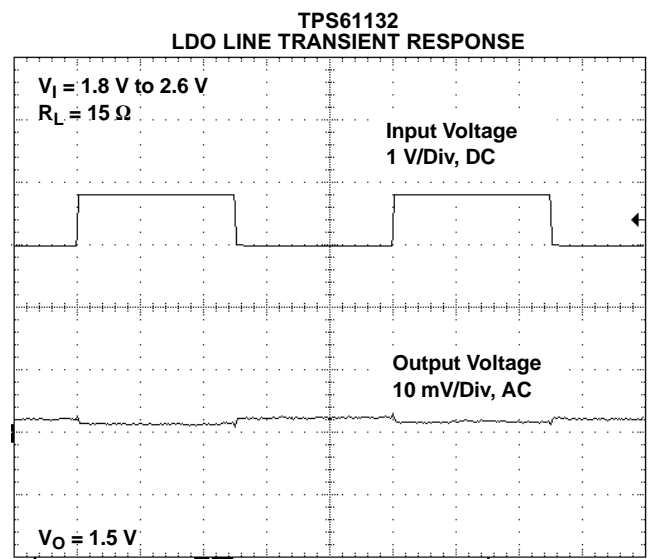

Figure 20.



Timebase – 500 μs/Div
 Figure 21.



Timebase – 2 ms/Div
 Figure 22.

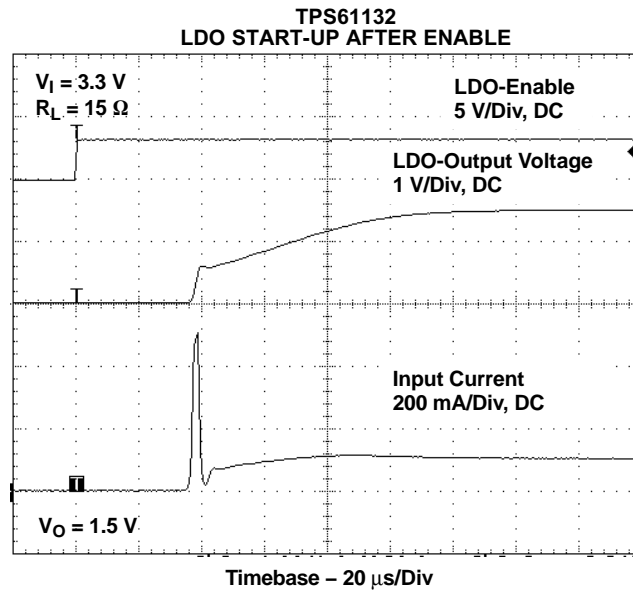

Figure 23.

APPLICATION INFORMATION

DESIGN PROCEDURE

The TPS6113x dc/dc converters are intended for systems powered by a dual up to 4 cell NiCd or NiMH battery with a typical terminal voltage between 1.8 V and 6.0 V. They can also be used in systems powered by one-cell Li-Ion with a typical stack voltage between 2.5 V and 4.2 V. Additionally, two up to four primary and secondary alkaline battery cells can be the power source in systems where the TPS6113x is used.

Programming the Output Voltage

DC/DC Converter

The output voltage of the TPS61130 dc/dc converter section can be adjusted with an external resistor divider. The typical value of the voltage on the FB pin is 500 mV. The maximum allowed value for the output voltage is 5.5 V. The current through the resistive divider should be about 100 times greater than the current into the FB pin. The typical current into the FB pin is 0.01 μ A and the voltage across R6 is typically 500 mV. Based on those two values, the recommended value for R6 should be lower than 500 k Ω , in order to set the divider current at 1 μ A or higher. Because of internal compensation circuitry the value for this resistor should be in the range of 200 k Ω . From that, the value of resistor R3, depending on the needed output voltage (V_O), can be calculated using Equation 1:

$$R3 = R6 \times \left(\frac{V_O}{V_{FB}} - 1 \right) = 180 \text{ k}\Omega \times \left(\frac{V_O}{500 \text{ mV}} - 1 \right) \quad (1)$$

If as an example, an output voltage of 3.3 V is needed, a 1-M Ω resistor should be chosen for R3. If for any reason the value for R6 is chosen significantly lower than 200 k Ω additional capacitance in parallel to R3 is recommended. The required capacitance value can be easily calculated using Equation 2.

$$C_{\text{par}R3} = 20 \text{ pF} \times \left(\frac{200 \text{ k}\Omega}{R6} - 1 \right) \quad (2)$$

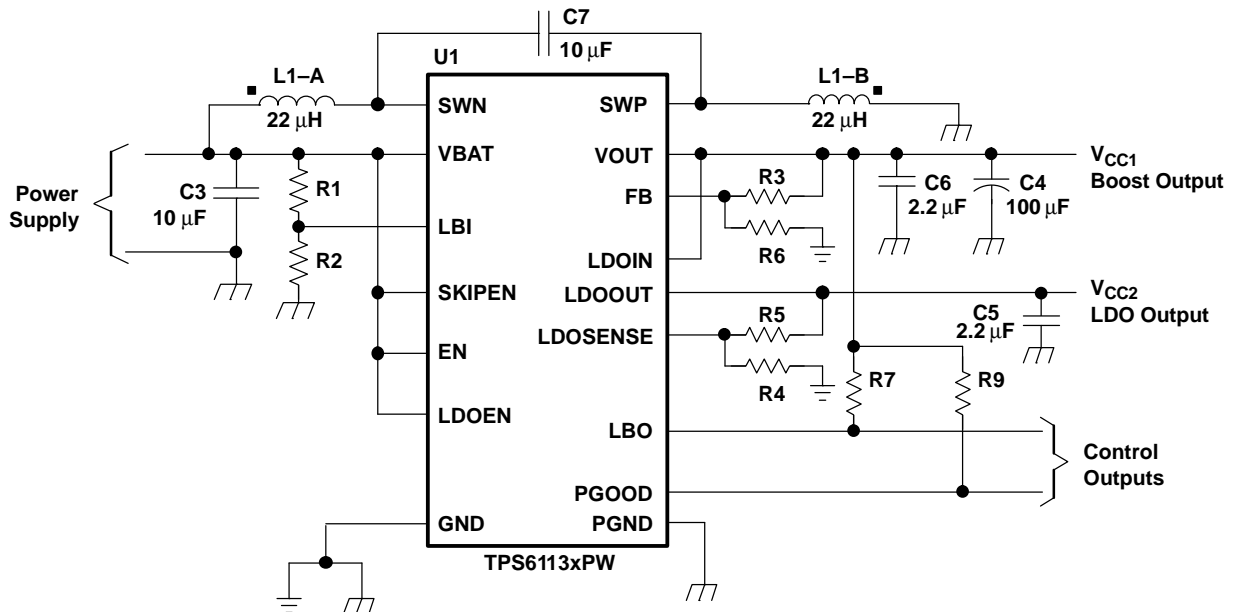

Figure 24. Typical Application Circuit for Adjustable Output Voltage Option

APPLICATION INFORMATION (continued)

LDO

Programming the output voltage at the LDO follows almost the same rules as at the dc/dc converter section. The maximum programmable output voltage at the LDO is 5.5 V. Since reference and internal feedback circuitry are similar, as they are at the boost converter section, R4 also should be in the 200-kΩ range. The calculation of the value of R5 can be done using the following Equation 3:

$$R5 = R4 \times \left(\frac{V_O}{V_{FB}} - 1 \right) = 180 \text{ k}\Omega \times \left(\frac{V_O}{500 \text{ mV}} - 1 \right) \quad (3)$$

If as an example, an output voltage of 1.5 V is needed, a 360 kΩ-resistor should be chosen for R5.

Programming the LBI/LBO Threshold Voltage

The current through the resistive divider should be about 100 times greater than the current into the LBI pin. The typical current into the LBI pin is 0.01 μA, and the voltage across R2 is equal to the LBI voltage threshold that is generated on-chip, which has a value of 500 mV. The recommended value for R2 is therefore in the range of 500 kΩ. From that, the value of resistor R1, depending on the desired minimum battery voltage V_{BAT} , can be calculated using Equation 4.

$$R1 = R2 \times \left(\frac{V_{BAT}}{V_{LBI - \text{threshold}}} - 1 \right) = 390 \text{ k}\Omega \times \left(\frac{V_{BAT}}{500 \text{ mV}} - 1 \right) \quad (4)$$

The output of the low battery supervisor is a simple open-drain output that goes active low if the dedicated battery voltage drops below the programmed threshold voltage on LBI. The output requires a pullup resistor with a recommended value of 1 MΩ. The maximum voltage which is used to pull up the LBO outputs should not exceed the output voltage of the dc/dc converter. If not used, the LBO pin can be left floating or tied to GND.

Inductor Selection

A SEPIC converter normally requires three main passive components for storing energy during the conversion. Two inductors, a flying capacitor, and a storage capacitor at the output are required. To select the two inductors, it is recommended to keep the possible peak inductor current below the current limit threshold of the power switch in the chosen configuration. For example, the current limit threshold of the TPS6113x's switch is 1600 mA at an output voltage of 3.3 V. The highest peak current through the switch is the sum of the two inductors currents and depends on the output load, the input (V_{BAT}), and the output voltage (V_{OUT}). Estimation of the maximum average inductor current of each inductor can be done using Equation 5:

$$I_{L1-A} = I_{L1-B} = I_{OUT} \times \frac{V_{OUT}}{V_{BAT} \times 0.8} \quad (5)$$

For example, for an output current of 300 mA at 3.3 V, at least 680 mA of average current flows through each of the the inductors at a minimum input voltage of 1.8 V.

The second parameter for choosing the inductor is the desired current ripple in the inductor. Normally, it is advisable to work with a ripple of around ±20% of the average inductor current. A smaller ripple reduces the magnetic hysteresis losses in the inductor, as well as output voltage ripple and EMI. But in the same way, regulation time at load changes rises. In addition, a larger inductor increases the total system costs. With those parameters, it is possible to calculate the value for the inductor by using Equation 6:

$$L1 - A = L1 - B = \frac{V_{BAT} \times V_{OUT}}{\Delta I_L \times f \times (V_{OUT} + V_{BAT})} \quad (6)$$

APPLICATION INFORMATION (continued)

Parameter f is the switching frequency and ΔI_L is the ripple current in the inductor, i.e., $40\% \times I_L$. In this example, the desired inductance value is in the range of 20 μH . With this calculated value and the calculated currents, it is possible to choose a suitable inductor. Care has to be taken that load transients and losses in the circuit can lead to higher currents as estimated in Equation 6. Also, the losses in the inductor caused by magnetic hysteresis losses and copper losses are a major parameter for total circuit efficiency.

The following inductor series from different suppliers were tested. All work with the TPS6113x converter within their specified parameters.

List of Inductors

VENDOR	RECOMMENDED INDUCTOR SERIES	COUPLED INDUCTOR SERIES
Sumida	CDRH73	
	CDRH74	
	CDRH5D18	
Würth Elektronik	7447789__	744878220
	7447779__	744877220
Cooper Electronics Technologies	DR73	DRQ73
	DR74	DRQ74
EPCOS	B82462G	

Capacitor Selection

Input Capacitor

At least a 10- μF input capacitor is recommended to improve transient behavior of the regulator and EMI behavior of the total power supply circuit. A ceramic capacitor or a tantalum capacitor with a 100-nF ceramic capacitor in parallel, placed close to the IC, is recommended.

Flying Capacitor DC/DC Converter

In the normal operating mode, the *flying* capacitor (C_7) must be large enough so that the voltage across the capacitor is small. This means the resonance frequency formed by the *flying* capacitor and the inductors must be at least ten times lower than the switching frequency (see Equation 7).

$$C_{\min} = \frac{100}{4\pi^2 f^2 L} \quad (7)$$

Where L is the inductance of L1-A or L1-B.

To optimize efficiency, capacitors with very low ESR such as ceramic capacitors are recommended. The voltage rating of the *flying* capacitor must be higher than the input voltage V_{BAT} .

Output Capacitor DC/DC Converter

The major parameter necessary to define the output capacitor is the maximum allowed output voltage ripple of the converter. This ripple is determined by two parameters of the capacitor, the capacitance and the ESR. It is possible to calculate the minimum capacitance needed for the defined ripple, supposing that the ESR is zero, by using Equation 8:

$$C_{\min} = \frac{I_{\text{OUT}} \times V_{\text{OUT}}}{f \times \Delta V \times (V_{\text{OUT}} + V_{\text{BAT}})} \quad (8)$$

Parameter f is the switching frequency and ΔV is the maximum allowed ripple.

With a chosen ripple voltage of 15 mV, a minimum capacitance of 26 μF is needed. The total ripple is larger due to the ESR of the output capacitor. This additional component of the ripple can be calculated using Equation 9:

$$\Delta V_{\text{ESR}} = I_{\text{OUT}} \times R_{\text{ESR}} \quad (9)$$

An additional ripple of 24 mV is the result of using a tantalum capacitor with a low ESR of 80 mΩ. The total ripple is the sum of the ripple caused by the capacitance and the ripple caused by the ESR of the capacitor. In this example, the total ripple is 39 mV. Additional ripple is caused by load transients. This means that the output capacitance needs to be larger than calculated above to meet the total ripple requirements. The output capacitor has to completely supply the load during the charging phase of the inductor. A reasonable value of the output capacitance depends on the speed of the load transients and the load current during the load change. With the calculated minimum value of 26 μF and load transient considerations, a reasonable output capacitance value is in a 100 μF range. For economical reasons this usually is a tantalum capacitor. Because of this the control loop has been optimized for using output capacitors with an ESR of above 30 mΩ.

Small Signal Stability

When using output capacitors with lower ESR, like ceramics, it is recommended to use the adjustable voltage version. The missing ESR can be easily compensated there in the feedback divider. Typically a capacitor in the range of 10 pF in parallel with R3 helps to obtain small signal stability, with the lowest ESR output capacitors. For more detailed analysis the small signal transfer function of the error amplifier and regulator, which is given in Equation 10, can be used.

$$A_{\text{REG}} = \frac{d}{V_{\text{FB}}} = \frac{10 \times (R3 + R6)}{R6 \times (1 + i \times \omega \times 1.6 \mu\text{s})} \quad (10)$$

Output Capacitor LDO

To ensure stable output regulation, it is required to use an output capacitor at the LDO output. We recommend using ceramic capacitors in the range from 1 μF up to 4.7 μF. At 4.7 μF and above it is recommended to use standard ESR tantalum. There is no maximum capacitance value.

Layout Considerations

For all switching power supplies, the layout is an important step in the design, especially at high peak currents and high switching frequencies. If the layout is not carefully done, the regulator could show stability problems as well as EMI problems. Therefore, use wide and short traces for the main current path and for the power ground tracks. The input capacitor, output capacitor, and the inductor should be placed as close as possible to the IC. Use a common ground node for power ground and a different one for control ground to minimize the effects of ground noise. Connect these ground nodes at any place close to one of the ground pins of the IC.

The feedback divider should be placed as close as possible to the control ground pin of the IC. To lay out the control ground, it is recommended to use short traces as well, separated from the power ground traces. This avoids ground shift problems, which can occur due to superimposition of power ground current and control ground current.

APPLICATION EXAMPLES

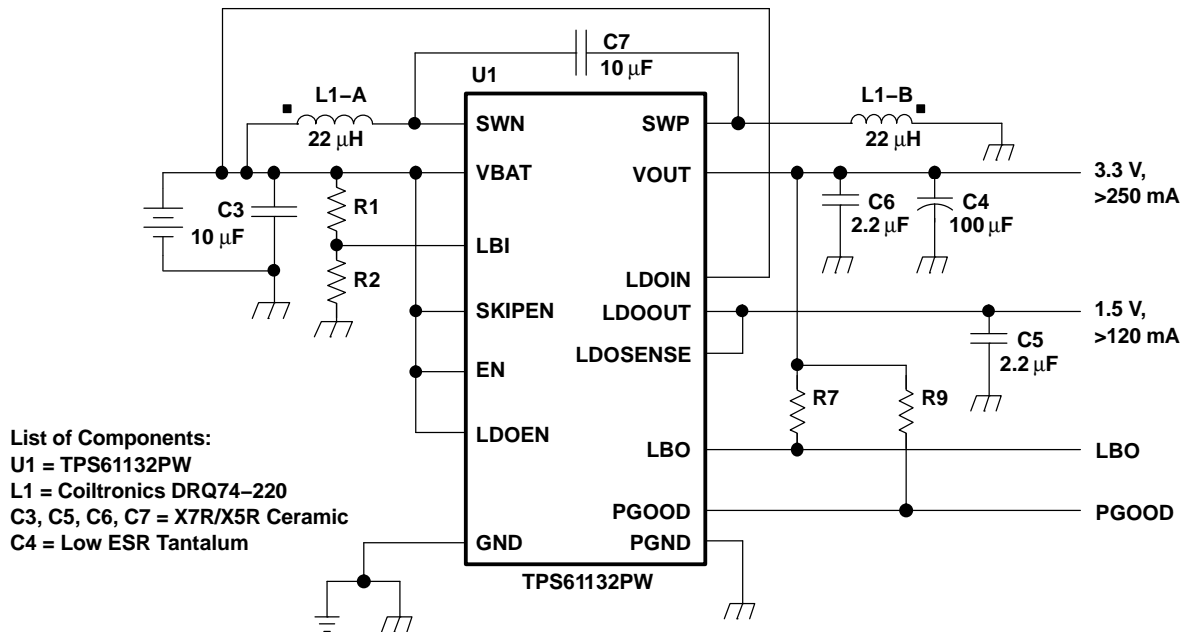

Figure 25. Solution for Maximum Output Power

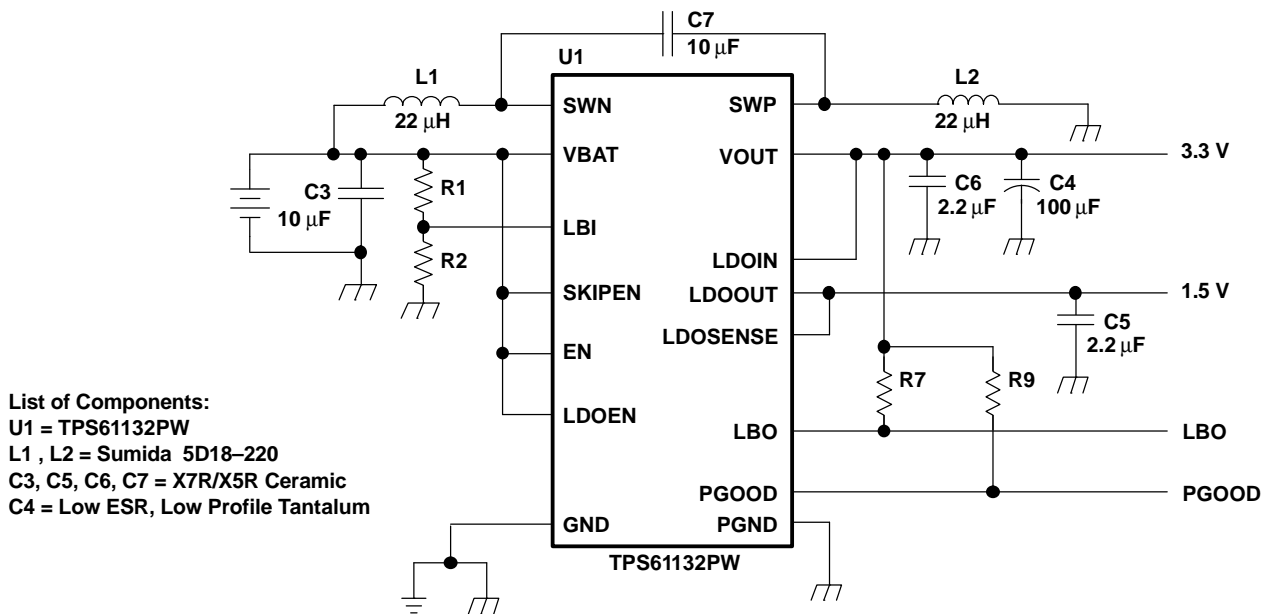

Figure 26. Low Profile Solution, Maximum Height 1,8 mm

APPLICATION EXAMPLES (continued)

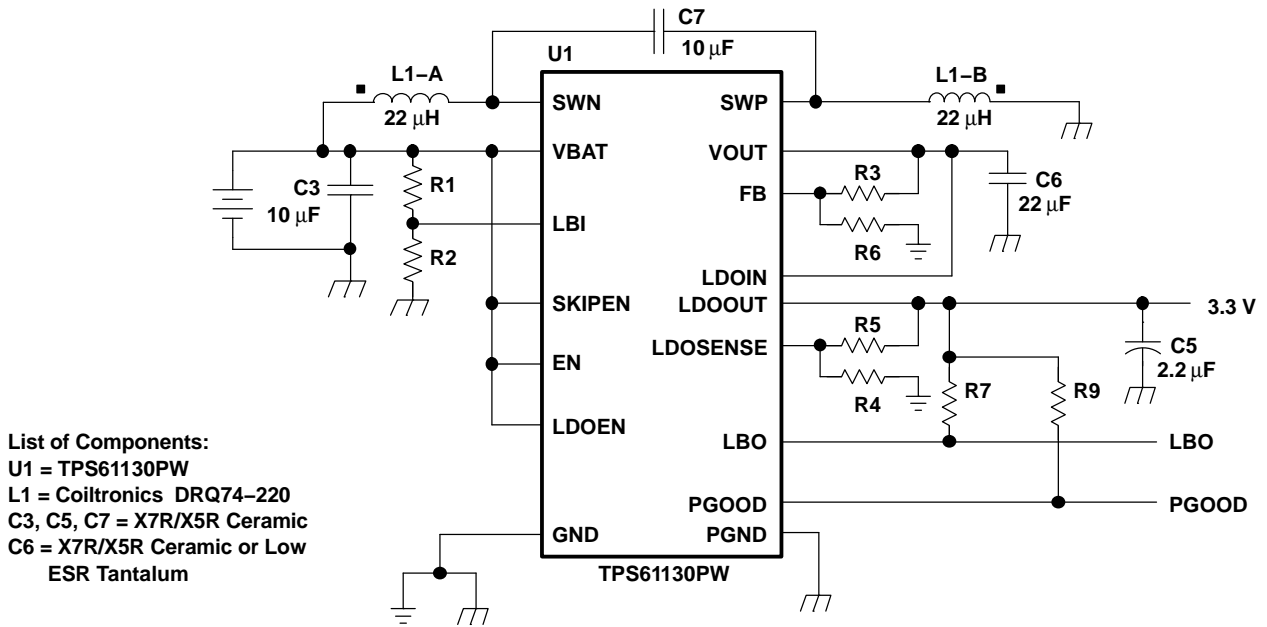

Figure 27. Single Output Using LDO as Filter

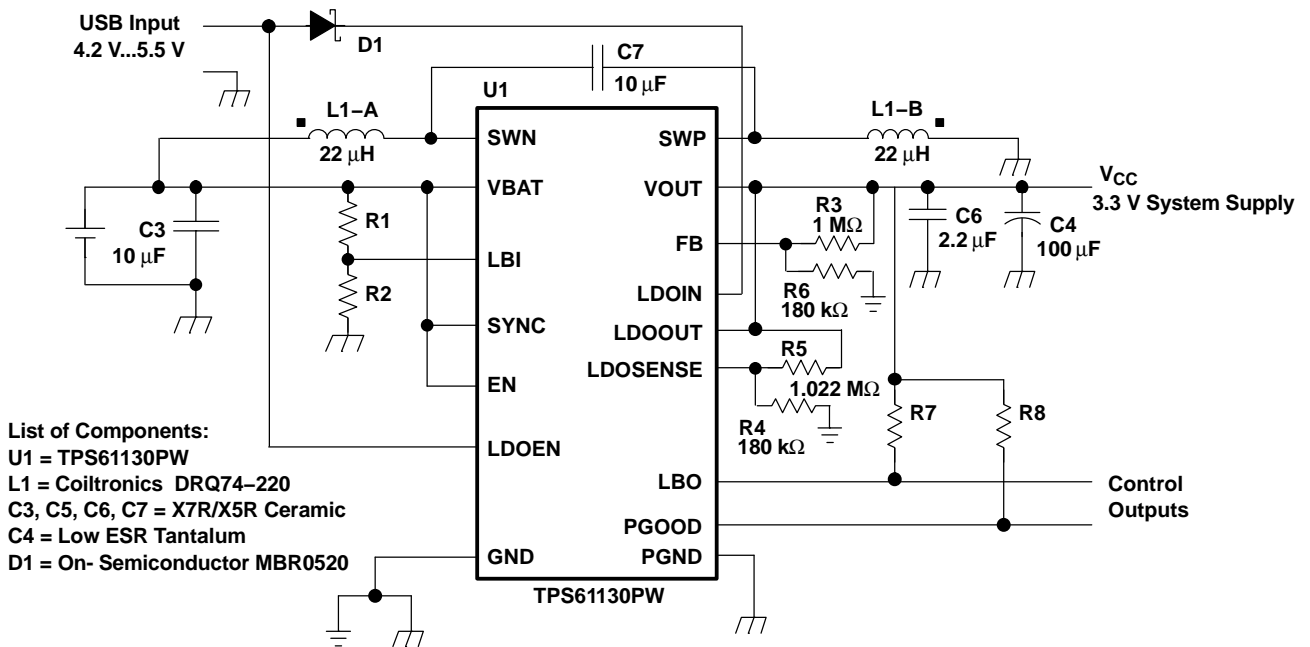

Figure 28. Dual Input Power Supply Solution

DETAILED DESCRIPTION

Synchronous Rectifier

The device integrates an N-channel and a P-channel MOSFET transistor to realize a synchronous rectifier. Because the commonly used discrete Schottky rectifier is replaced with a low RDS(ON) PMOS switch, the power conversion efficiency reaches 90%. To avoid ground shift due to the high currents in the NMOS switch, two separate ground pins are used. The reference for all control functions is the GND pin. The source of the NMOS switch is connected to PGND. Both grounds must be connected on the PCB at only one point close to the GND pin. Due to the nature of the SEPIC topology, there is no dc path from the battery to the output. No additional components must be added in a SEPIC or Flyback topology to make sure the battery is disconnected from the output of the converter.

Nevertheless, the backgate diode of the high-side PMOS which is forward biased in standard operation, is turned off in shutdown. This is done by a special circuit which takes the cathode of the backgate diode of the high-side PMOS and disconnects it from the source when the regulator is not enabled (EN = low).

Controller Circuit

The controller circuit of the device is based on a fixed frequency multiple feedforward controller topology. Input voltage, output voltage, and voltage drop on the NMOS switch are monitored and forwarded to the regulator. So changes in the operating conditions of the converter directly affect the duty cycle and must not take the indirect and slow way through the control loop and the error amplifier. The control loop, determined by the error amplifier, only has to handle small signal errors. The input for it is the feedback voltage on the FB pin or, at fixed output voltage versions, the voltage on the internal resistor divider. It is compared with the internal reference voltage to generate an accurate and stable output voltage.

The peak current of the NMOS switch is also sensed to limit the maximum current flowing through the switch and the inductor. The typical peak current limit is set to 1300 mA.

An internal temperature sensor prevents the device from getting overheated in case of excessive power dissipation.

Device Enable

The device is put into operation when EN is set high. It is put into a shutdown mode when EN is set to GND. In shutdown mode, the regulator stops switching, all internal control circuitry including the low-battery comparator is switched off, and the backgate diode of the rectifying switch is turned off (as described in the Synchronous Rectifier Section). This also means that the output voltage can drop below the input voltage during shutdown. During start-up of the converter, the duty cycle and the peak current are limited in order to avoid high peak currents drawn from the battery.

Undervoltage Lockout

An undervoltage lockout function prevents device start-up if the supply voltage on VBAT is lower than approximately 1.6 V. When in operation and the battery is being discharged, the device automatically enters the shutdown mode if the voltage on VBAT drops below approximately 1.6 V. This undervoltage lockout function is implemented in order to prevent the malfunctioning of the converter.

Softstart

When the SEPIC section is enabled, the internal startup cycle starts with switching at a duty cycle of 50%. After the output voltage has reached approximately 1.4V the device continues switching with a variable duty cycle. Until the programmed output voltage is reached, the main switch current limit is set to 40% of its nominal value to avoid high peak inrush currents at the battery during startup. Also the maximum output power during output short circuit conditions is reduced. When the programmed output voltage is reached, the regulator takes control and the switch current limit is set back to 100%.

DETAILED DESCRIPTION (continued)

LDO Enable

The LDO can be separately enabled and disabled by using the LDOEN pin in the same way as the EN pin at the dc/dc converter stage described above. This is completely independent of the status of the EN pin. The voltage levels of the logic signals which need to be applied at LDOEN are related to LDOIN.

Power Good

The PGOOD pin stays high impedance when the dc/dc converter delivers an output voltage within a defined voltage window. So it can be used to enable any connected circuitry such as cascaded converters (LDO) or microprocessor circuits.

Power Save Mode

The SKIPEN pin can be used to select different operation modes. To enable the power save mode, SKIPEN must be set high. Power save mode is used to improve efficiency at light loads. In power save mode, the converter only operates when the output voltage trips below a set threshold voltage. It ramps up the output voltage with several pulses, and goes again into power save mode once the output voltage exceeds the set threshold voltage. The power save mode can be disabled by setting the SKIPEN to GND.

Low Battery Detector Circuit—LBI/LBO

The low-battery detector circuit is typically used to supervise the battery voltage and to generate an error flag when the battery voltage drops below a user-set threshold voltage. The function is active only when the device is enabled. When the device is disabled, the LBO pin is high-impedance. The switching threshold is 500 mV at LBI. During normal operation, LBO stays at high impedance when the voltage, applied at LBI, is above the threshold. It is active low when the voltage at LBI goes below 500 mV.

The battery voltage, at which the detection circuit switches, can be programmed with a resistive divider connected to the LBI pin. The resistive divider scales down the battery voltage to a voltage level of 500 mV, which is then compared to the LBI threshold voltage. The LBI pin has a built-in hysteresis of 10 mV. See the application section for more details about the programming of the LBI threshold. If the low-battery detection circuit is not used, the LBI pin should be connected to GND (or to VBAT) and the LBO pin can be left unconnected. Do not let the LBI pin float.

Low-EMI Switch

The device integrates a circuit that removes the ringing that typically appears on the SW node when the converter enters discontinuous current mode. In this case, the current through the inductor ramps to zero and the rectifying PMOS switch is turned off to prevent a reverse current flowing from the output capacitors back to the battery. Due to the remaining energy that is stored in parasitic components of the semiconductor and the inductor, a ringing on the SW pin is induced. The integrated antiringing switch clamps this voltage to VBAT and therefore dampens ringing.

LDO

The built-in LDO can be used to generate a second output voltage derived from the dc/dc converter output, from the battery, or from another power source like an ac adapter or a USB power rail. The LDO is capable of being back biased. This allows the user just to connect the outputs of dc/dc converter and LDO. So the device is able to supply the load via dc/dc converter when the energy comes from the battery and efficiency is most important and from another external power source via the LDO when lower efficiency is not critical. The LDO must be disabled if the LDOIN voltage drops below LDOOUT to block reverse current flowing. The status of the dc/dc stage (enabled or disabled) does not matter.

THERMAL INFORMATION

Implementation of integrated circuits in low-profile and fine-pitch surface-mount packages typically requires special attention to power dissipation. Many system-dependent issues such as thermal coupling, airflow, added heat sinks and convection surfaces, and the presence of other heat-generating components affect the power-dissipation limits of a given component.

Three basic approaches for enhancing thermal performance are listed below.

- Improving the power dissipation capability of the PCB design.
- Improving the thermal coupling of the component to the PCB.
- Introducing airflow in the system.

The maximum junction temperature (T_J) of the TPS6113x devices is 150°C. The thermal resistance of the 16-pin TSSOP package (PW) is $R_{\theta JA} = 155\text{ }^\circ\text{C/W}$. The 16-pin QFN PowerPAD package (RSA) has a thermal resistance of $R_{\theta JA} = 38.1\text{ }^\circ\text{C/W}$, if the PowerPAD is soldered and the board layout is optimized. Specified regulator operation is assured to a maximum ambient temperature T_A of 85°C. Therefore, the maximum power dissipation is about 420 mW for the TSSOP (PW) package and 1700 mW for the QFN (RSA) package. More power can be dissipated if the maximum ambient temperature of the application is lower.(see Equation 11).

$$P_{D(\text{MAX})} = \frac{T_{J(\text{MAX})} - T_A}{R_{\theta JA}} = \frac{150^\circ\text{C} - 85^\circ\text{C}}{155^\circ\text{C/W}} = 420\text{ mW} \quad (11)$$

If designing for a lower junction temperature of 125°C, which is recommended, maximum heat dissipation is lower. Using the above Equation 11 results in 1050 mW power dissipation for the RSA package and 260 mW for the PW package.

RSA (S-PQFP-N16)

PLASTIC QUAD FLATPACK

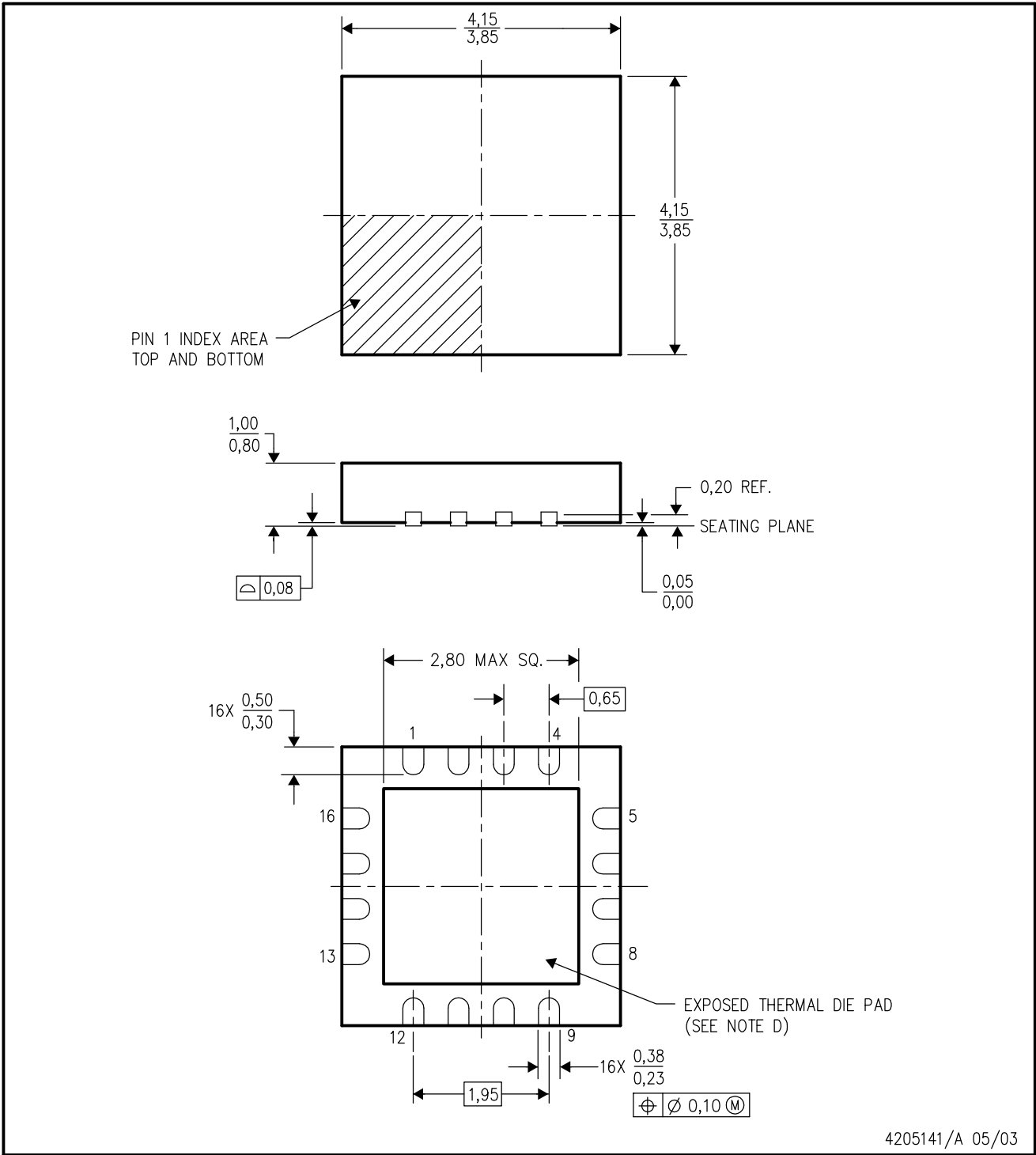

4205141/A 05/03

- NOTES:
- A. All linear dimensions are in millimeters.
 - B. This drawing is subject to change without notice.
 - C. Quad Flatpack, No-leads (QFN) package configuration.
 - D. The package thermal performance may be enhanced by bonding the thermal die pad to an external thermal plane.
 - E. Falls within JEDEC MO-220.

PACKAGING INFORMATION

Orderable Device	Status ⁽¹⁾	Package Type	Package Drawing	Pins	Package Qty	Eco Plan ⁽²⁾	Lead/Ball Finish	MSL Peak Temp ⁽³⁾
TPS61130PW	ACTIVE	TSSOP	PW	16	90	TBD	CU NIPDAU	Level-1-220C-UNLIM
TPS61130PWR	ACTIVE	TSSOP	PW	16	2000	TBD	CU NIPDAU	Level-1-220C-UNLIM
TPS61130RSAR	ACTIVE	QFN	RSA	16	3000	TBD	CU NIPDAU	Level-2-235C-1 YEAR
TPS61131PW	ACTIVE	TSSOP	PW	16	90	TBD	CU NIPDAU	Level-1-220C-UNLIM
TPS61131PWR	ACTIVE	TSSOP	PW	16	2000	TBD	CU NIPDAU	Level-1-220C-UNLIM
TPS61132PW	ACTIVE	TSSOP	PW	16	90	TBD	CU NIPDAU	Level-1-220C-UNLIM
TPS61132PWR	ACTIVE	TSSOP	PW	16	2000	TBD	CU NIPDAU	Level-1-220C-UNLIM
TPS61132RSAR	ACTIVE	QFN	RSA	16	1	TBD	CU NIPDAU	Level-2-235C-1 YEAR

⁽¹⁾ The marketing status values are defined as follows:

ACTIVE: Product device recommended for new designs.

LIFEBUY: TI has announced that the device will be discontinued, and a lifetime-buy period is in effect.

NRND: Not recommended for new designs. Device is in production to support existing customers, but TI does not recommend using this part in a new design.

PREVIEW: Device has been announced but is not in production. Samples may or may not be available.

OBSOLETE: TI has discontinued the production of the device.

⁽²⁾ Eco Plan - The planned eco-friendly classification: Pb-Free (RoHS) or Green (RoHS & no Sb/Br) - please check <http://www.ti.com/productcontent> for the latest availability information and additional product content details.

TBD: The Pb-Free/Green conversion plan has not been defined.

Pb-Free (RoHS): TI's terms "Lead-Free" or "Pb-Free" mean semiconductor products that are compatible with the current RoHS requirements for all 6 substances, including the requirement that lead not exceed 0.1% by weight in homogeneous materials. Where designed to be soldered at high temperatures, TI Pb-Free products are suitable for use in specified lead-free processes.

Green (RoHS & no Sb/Br): TI defines "Green" to mean Pb-Free (RoHS compatible), and free of Bromine (Br) and Antimony (Sb) based flame retardants (Br or Sb do not exceed 0.1% by weight in homogeneous material)

⁽³⁾ MSL, Peak Temp. -- The Moisture Sensitivity Level rating according to the JEDEC industry standard classifications, and peak solder temperature.

Important Information and Disclaimer: The information provided on this page represents TI's knowledge and belief as of the date that it is provided. TI bases its knowledge and belief on information provided by third parties, and makes no representation or warranty as to the accuracy of such information. Efforts are underway to better integrate information from third parties. TI has taken and continues to take reasonable steps to provide representative and accurate information but may not have conducted destructive testing or chemical analysis on incoming materials and chemicals. TI and TI suppliers consider certain information to be proprietary, and thus CAS numbers and other limited information may not be available for release.

In no event shall TI's liability arising out of such information exceed the total purchase price of the TI part(s) at issue in this document sold by TI to Customer on an annual basis.

RSA (S-PQFP-N16)

PLASTIC QUAD FLATPACK

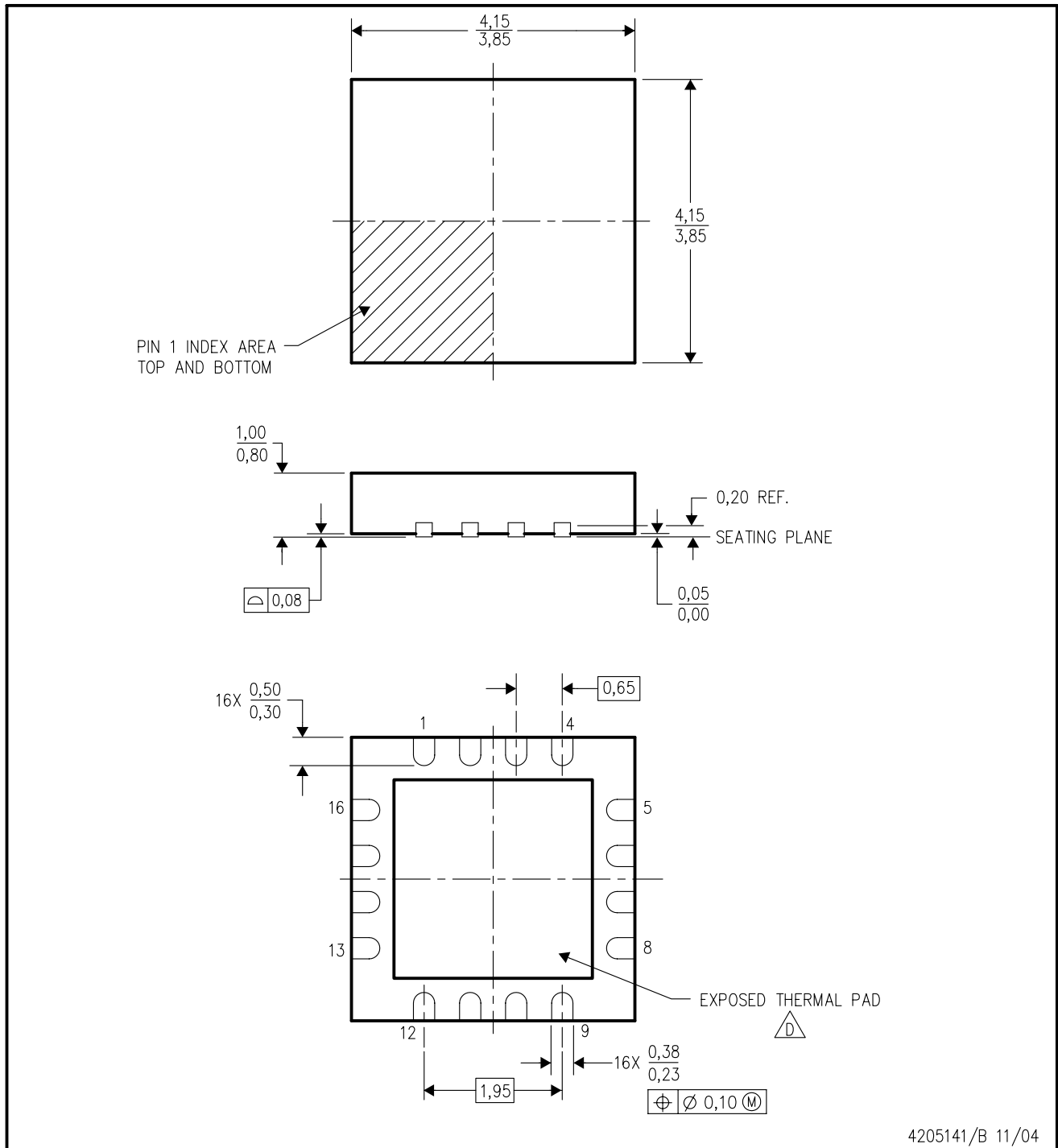

- NOTES:
- A. All linear dimensions are in millimeters. Dimensioning and tolerancing per ASME Y14.5M-1994.
 - B. This drawing is subject to change without notice.
 - C. Quad Flatpack, No-leads (QFN) package configuration.
 - \triangle The package thermal pad must be soldered to the board for thermal and mechanical performance. See the Product Data Sheet for details regarding the exposed thermal pad dimensions.
 - E. Falls within JEDEC MO-220.

PW (R-PDSO-G**)

PLASTIC SMALL-OUTLINE PACKAGE

14 PINS SHOWN



4040064/F 01/97

- NOTES: A. All linear dimensions are in millimeters.
 B. This drawing is subject to change without notice.
 C. Body dimensions do not include mold flash or protrusion not to exceed 0,15.
 D. Falls within JEDEC MO-153

IMPORTANT NOTICE

Texas Instruments Incorporated and its subsidiaries (TI) reserve the right to make corrections, modifications, enhancements, improvements, and other changes to its products and services at any time and to discontinue any product or service without notice. Customers should obtain the latest relevant information before placing orders and should verify that such information is current and complete. All products are sold subject to TI's terms and conditions of sale supplied at the time of order acknowledgment.

TI warrants performance of its hardware products to the specifications applicable at the time of sale in accordance with TI's standard warranty. Testing and other quality control techniques are used to the extent TI deems necessary to support this warranty. Except where mandated by government requirements, testing of all parameters of each product is not necessarily performed.

TI assumes no liability for applications assistance or customer product design. Customers are responsible for their products and applications using TI components. To minimize the risks associated with customer products and applications, customers should provide adequate design and operating safeguards.

TI does not warrant or represent that any license, either express or implied, is granted under any TI patent right, copyright, mask work right, or other TI intellectual property right relating to any combination, machine, or process in which TI products or services are used. Information published by TI regarding third-party products or services does not constitute a license from TI to use such products or services or a warranty or endorsement thereof. Use of such information may require a license from a third party under the patents or other intellectual property of the third party, or a license from TI under the patents or other intellectual property of TI.

Reproduction of information in TI data books or data sheets is permissible only if reproduction is without alteration and is accompanied by all associated warranties, conditions, limitations, and notices. Reproduction of this information with alteration is an unfair and deceptive business practice. TI is not responsible or liable for such altered documentation.

Resale of TI products or services with statements different from or beyond the parameters stated by TI for that product or service voids all express and any implied warranties for the associated TI product or service and is an unfair and deceptive business practice. TI is not responsible or liable for any such statements.

Following are URLs where you can obtain information on other Texas Instruments products and application solutions:

Products		Applications	
Amplifiers	amplifier.ti.com	Audio	www.ti.com/audio
Data Converters	dataconverter.ti.com	Automotive	www.ti.com/automotive
DSP	dsp.ti.com	Broadband	www.ti.com/broadband
Interface	interface.ti.com	Digital Control	www.ti.com/digitalcontrol
Logic	logic.ti.com	Military	www.ti.com/military
Power Mgmt	power.ti.com	Optical Networking	www.ti.com/opticalnetwork
Microcontrollers	microcontroller.ti.com	Security	www.ti.com/security
		Telephony	www.ti.com/telephony
		Video & Imaging	www.ti.com/video
		Wireless	www.ti.com/wireless

Mailing Address: Texas Instruments
Post Office Box 655303 Dallas, Texas 75265