

UTC TIP110A PNP EXPITAXIAL PLANAR TRANSISTOR

LOW SATURATION VOLTAGE PNP DARLINGTON TRANSISTOR

DESCRIPTION

The UTC TIP110A is designed for using in general purpose amplifier and switching applications.

FEATURE

- *Low VCE(sat)
- *High current gain

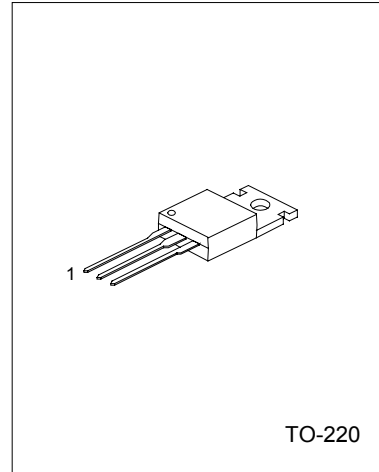

1:BASE 2:COLLECTOR 3:EMITTER

MAXIMUM RATINGS(Ta=25°C)

CHARACTERISTICS	SYMBOL	VALUE	UNITS
Collector Base Voltage	V _{CB0}	40	V
Collector to Emitter Voltage	V _{CEO}	30	V
Emitter To base Voltage	V _{EB0}	5	V
Collector Current	I _c	10	A
Junction Temperature	T _j	150(Max)	°C
Storage Temperature	T _{stg}	-55 ~ +150	°C
Total Power Dissipations	P _D	65	W

CHARACTERISTICS(Ta=25°C)

SYMBOL	TEST CONDITIONS	MIN	TYP	MAX	UNIT
BV _{CEO}	I _c =100mA	30			V
I _{CB0}	V _{CB} =40V			1	μA
I _{CEO}	V _{CE} =20V			1	μA
I _{EB0}	V _{EB} =5V			100	nA
V _{CE(SAT)}	I _c =10A, I _b =10mA			2.0	V
V _{BE(ON)}	I _c =5mA, V _{CE} =2.0V			2.0	V
h _{FE1}	I _c =500mA, V _{CE} =2.0V	2		60	K
h _{FE2}	I _c =10A, V _{CE} =2.0V	1	20	60	K

UTCTIP110A PNEXPITAXIAL PLANAR TRANSISTOR

TYPICAL PERFORMANCE CHARACTERISTICS

