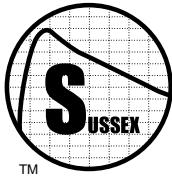


SUSSEX SEMICONDUCTOR, INC.
Bridge Rectifiers

SECTION 4



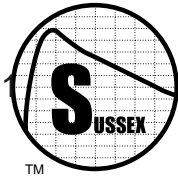
SUSSEX
SEMICONDUCTOR, INC.

**TABLE OF
CONTENTS**

12251 TOWNE LAKE DRIVE, FORT MYERS, FLORIDA, 33913 • TEL: (239) 768-6800 • FAX: (239) 768-6868

TABLE OF CONTENTS

DEVICE TYPE	PAGE NUMBER
1) 1.0 AMP SINGLE - PHASE BRIDGE RECTIFIER.....	4-1
BDG-D1.0-50 THROUGH BDG-D1.0-1000	
2) 1.5 AMP SINGLE - PHASE BRIDGE RECTIFIER.....	4-3
BDG-C1.5-50 THROUGH BDG-C1.5-1000	
3) 2.0 AMP SINGLE - PHASE IN-LINE BRIDGE RECTIFIER.....	4-5
BDG-R2.0-50 THROUGH BDG-R2.0-1000	
4) 4.0 AMP SINGLE - PHASE IN-LINE BRIDGE RECTIFIER.....	4-7
BDG-R4.0-50 THROUGH BDG-R4.0-1000	
5) 6.0 AND 8.0 AMP SINGLE - PHASE IN-LINE BRIDGE RECTIFIER.....	4-9
BDG-R6.0-50 THROUGH BDG-R6.0-1000	
BDG-R8.0-50 THROUGH BDG-R8.0-1000	
6) 3.0 AND 6.0 AMP SINGLE - PHASE BRIDGE RECTIFIER.....	4-11
BDG-SL3.0-50 THROUGH BDG-SL3.0-1000	
BDG-SL6.0-50 THROUGH BDG-SL6.0-1000	
7) 8.0 AND 10.0 AMP SINGLE - PHASE BRIDGE RECTIFIER.....	4-13
BDG-SL8.0-50 THROUGH BDG-SL8.0-1000	
BDG-SL10.0-50 THROUGH BDG-SL10.0-1000	
8) 15.0 AMP SINGLE - PHASE BRIDGE RECTIFIER.....	4-15
BDG-ST15.0-50 THROUGH BDG-ST15.0-1000	
9) 25.0 AND 35.0 SINGLE - PHASE BRIDGE RECTIFIER.....	4-17
BDG-ST25.0-50 THROUGH BDG-ST25.0-1000	
BDG-ST35.0-50 THROUGH BDG-ST35.0-1000	

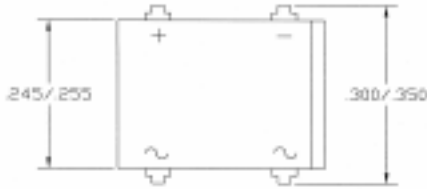


SUSSEX
SEMICONDUCTOR, INC.

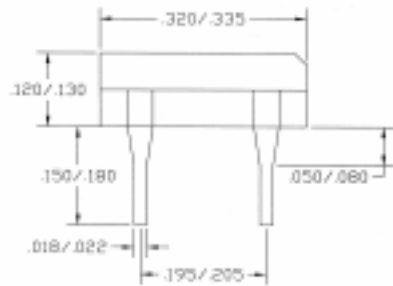
**1.0 AMP
BRIDGE RECTIFIERS**

12251 TOWNE LAKE DRIVE, FORT MYERS, FLORIDA, 33913 • TEL: (239) 768-6800 • FAX: (239) 768-6868

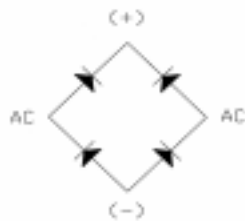
Top View



Side View



Electrical Schematic



All Dimensions In Inches

SINGLE - PHASE BRIDGE RECTIFIER

REVERSE VOLTAGES - 50 TO 1000 VOLTS

FORWARD CURRENT - 1.0 AMPS

1.0 AMP BRIDGE RECTIFIER SPECIFICATIONS

- ◆ Plated Leads Guarantee Excellent Solderability
- ◆ Molded Plastic Case
- ◆ Typical Leakage Current Less Than .1μA
- ◆ Ideal For Printed Circuit Boards
- ◆ Polarity Indicated By Solvent Resistant Marking
- ◆ Operating Temperature: -55 to 150°C
- ◆ Storage Temperature: -55 to 150°C
- ◆ High Isolation Resistance From Case To Leads

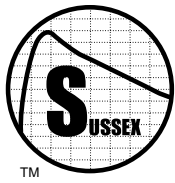
TABLE 1A - STANDARD DEVICE ELECTRICAL SPECIFICATIONS (NOTE 1)

SUSSEX PART NUMBER	MAX. AVERAGE FORWARD RECTIFIED OUTPUT CURRENT $T_{CASE} = 55^{\circ}C$ AMPS	MAX. INSTANTANEOUS FORWARD VOLTAGE PER BRIDGE ELEMENT		MAX. LEAKAGE CURRENT $I_R @ V_{DC}$		PEAK FORWARD SURGE CURRENT (NOTE 2) AMPS	MAX. RECURRENT PEAK REVERSE VOLTAGE (V_{RRM}) VOLTS	MAX. RMS INPUT VOLTAGE (V_{RMS}) VOLTS
		FORWARD VOLTAGE TEST CURRENT (I_F) AMPS	PEAK FORWARD VOLTAGE @ I_F VOLTS	V_{DC} VOLTS	I_R μA			
BDG-D1.0-50	1.0	1.0	1.1	50	5	50	50	35
BDG-D1.0-100	1.0	1.0	1.1	100	5	50	100	70
BDG-D1.0-200	1.0	1.0	1.1	200	5	50	200	140
BDG-D1.0-400	1.0	1.0	1.1	400	5	50	400	280
BDG-D1.0-600	1.0	1.0	1.1	600	5	50	600	420
BDG-D1.0-800	1.0	1.0	1.1	800	5	50	800	560
BDG-D1.0-1000	1.0	1.0	1.1	1000	5	50	1000	700

NOTES

NOTE 1 ◆ ELECTRICAL CHARACTERISTICS MEASURED AT 25°C UNLESS OTHERWISE STATED.

NOTE 2 ◆ PEAK FORWARD SURGE CURRENT MEASURED FROM A SINGLE SINE-WAVE BEING SUPERIMPOSED ON THE RATED LOAD (JEDEC METHOD).



SUSSEX
SEMICONDUCTOR, INC.

12251 TOWNE LAKE DRIVE, FORT MYERS, FLORIDA, 33913 • TEL: (239) 768-6800 • FAX: (239) 768-6868

**1.0 AMP
BRIDGES - CONTINUED**

FIGURE 1A - BRIDGE RECTIFIER DERATING CURVE

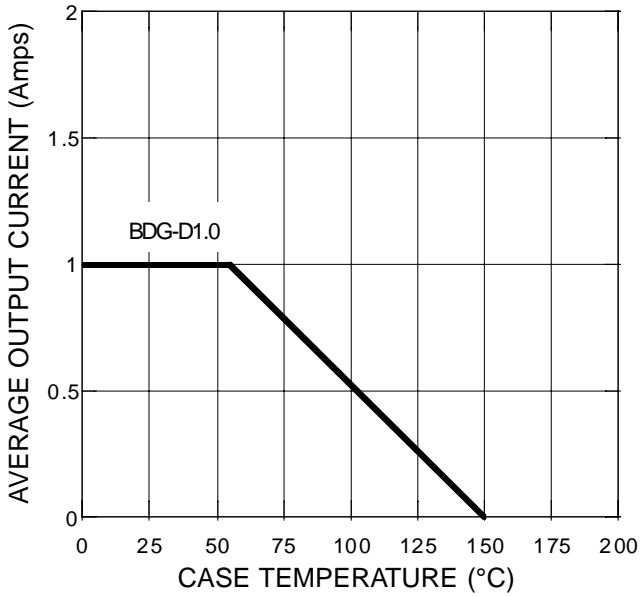


FIGURE 2A - TYPICAL JUNCTION CAPACITANCE PER LEG

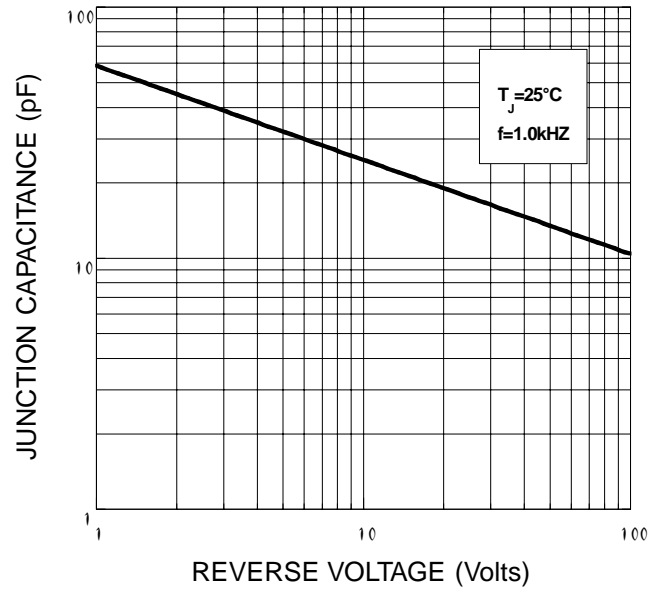


FIGURE 3A - TYPICAL FORWARD CHARACTERISTICS PER LEG

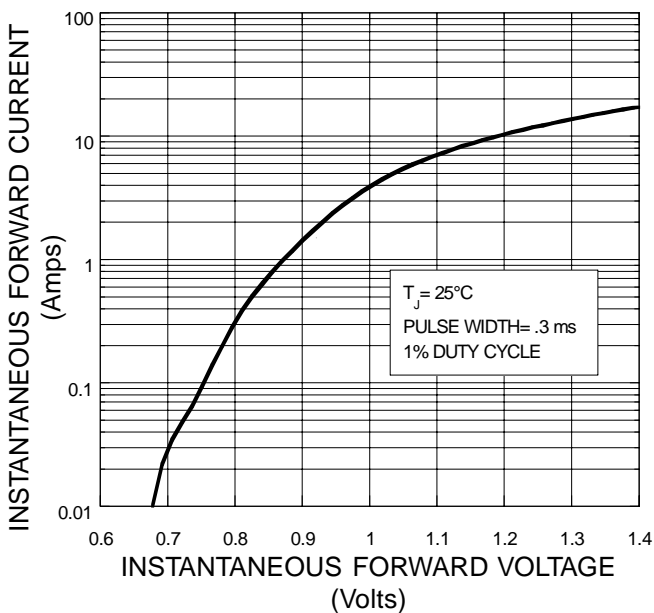
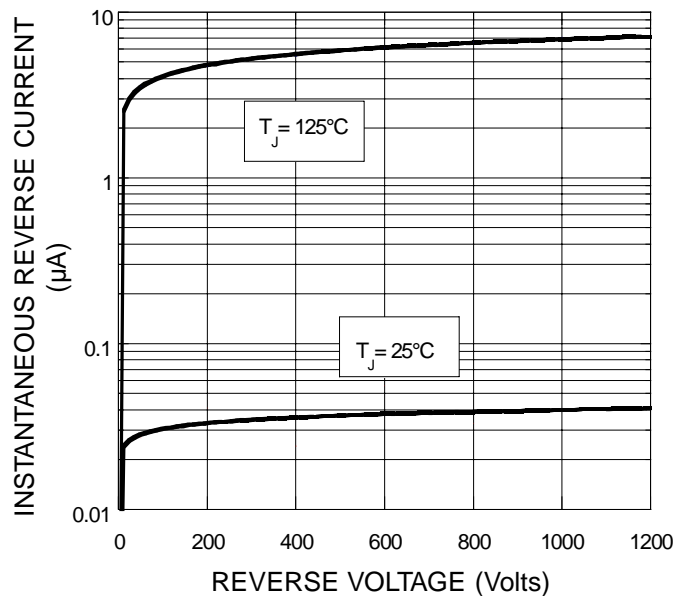
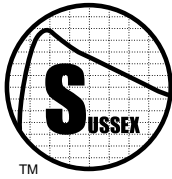


FIGURE 4A - TYPICAL REVERSE VOLTAGE CHARACTERISTICS PER LEG





SUSSEX
SEMICONDUCTOR, INC.

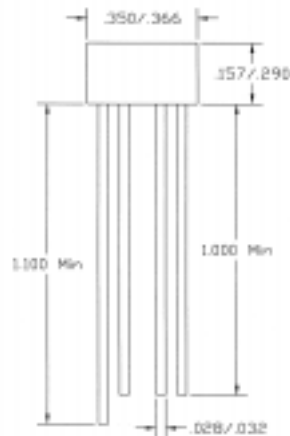
1.5 AMP BRIDGE RECTIFIERS

12251 TOWNE LAKE DRIVE, FORT MYERS, FLORIDA, 33913 • TEL: (239) 768-6800 • FAX: (239) 768-6868

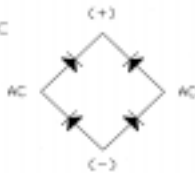
Top View



Side View



Electrical Schematic



All Dimensions In Inches

SINGLE - PHASE BRIDGE RECTIFIER

REVERSE VOLTAGES - 50 TO 1000 VOLTS

FORWARD CURRENT - 1.5 AMPS

1.5 AMP BRIDGE RECTIFIER SPECIFICATIONS

- ◆ Plated Leads Guarantee Excellent Solderability
- ◆ Encapsulated In An Epoxy Filled Plastic Case
- ◆ Typical Leakage Current Less Than .1 μ A
- ◆ Ideal For Printed Circuit Boards
- ◆ Polarity Indicated By Solvent Resistant Marking
- ◆ Operating Temperature: -50 to 125°C
- ◆ Storage Temperature: -50 to 150°C

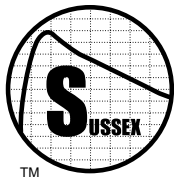
TABLE 1A - STANDARD DEVICE ELECTRICAL SPECIFICATIONS (NOTE 1)

SUSSEX PART NUMBER	MAX. AVERAGE FORWARD RECTIFIED OUTPUT CURRENT $T_{CASE}=55^{\circ}C$ AMPS	MAX. INSTANTANEOUS FORWARD VOLTAGE PER BRIDGE ELEMENT		MAX. LEAKAGE CURRENT $I_R @ V_{DC}$		PEAK FORWARD SURGE CURRENT (NOTE 2) AMPS	MAX. RECURRENT PEAK REVERSE VOLTAGE (V_{RRM}) VOLTS	MAX. RMS INPUT VOLTAGE (V_{RMS}) VOLTS
		FORWARD VOLTAGE TEST CURRENT (I_F) AMPS	PEAK FORWARD VOLTAGE @ I_F VOLTS	V_{DC} VOLTS	I_R μA			
BDG-C1.5-50	1.5	1.5	1.0	50	5	50	50	35
BDG-C1.5-100	1.5	1.5	1.0	100	5	50	100	70
BDG-C1.5-200	1.5	1.5	1.0	200	5	50	200	140
BDG-C1.5-400	1.5	1.5	1.0	400	5	50	400	280
BDG-C1.5-600	1.5	1.5	1.0	600	5	50	600	420
BDG-C1.5-800	1.5	1.5	1.0	800	5	50	800	560
BDG-C1.5-1000	1.5	1.5	1.0	1000	5	50	1000	700

NOTES

NOTE 1 ◆ ELECTRICAL CHARACTERISTICS MEASURED AT 25°C UNLESS OTHERWISE STATED.

NOTE 2 ◆ PEAK FORWARD SURGE CURRENT MEASURED FROM A SINGLE SINE-WAVE BEING SUPERIMPOSED ON THE RATED LOAD (JEDEC METHOD).

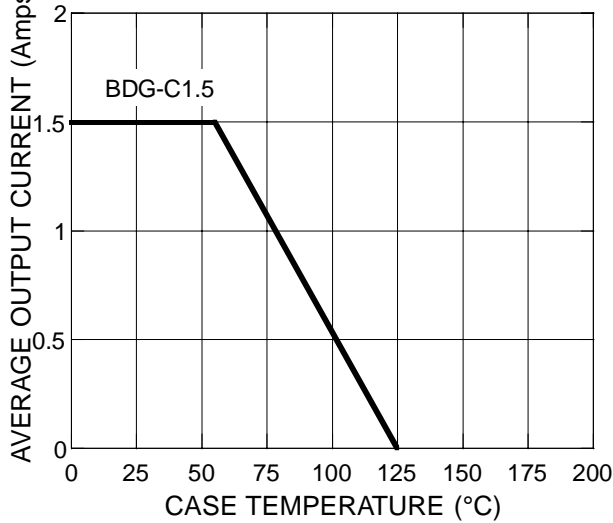


SUSSEX
SEMICONDUCTOR, INC.

12251 TOWNE LAKE DRIVE, FORT MYERS, FLORIDA, 33913 • TEL: (239) 768-6800 • FAX: (239) 768-6868

**1.5 AMP
BRIDGES - CONTINUED**

**FIGURE 1A - BRIDGE RECTIFIER
DERATING CURVE**



**FIGURE 2A - TYPICAL JUNCTION
CAPACITANCE PER LEG**

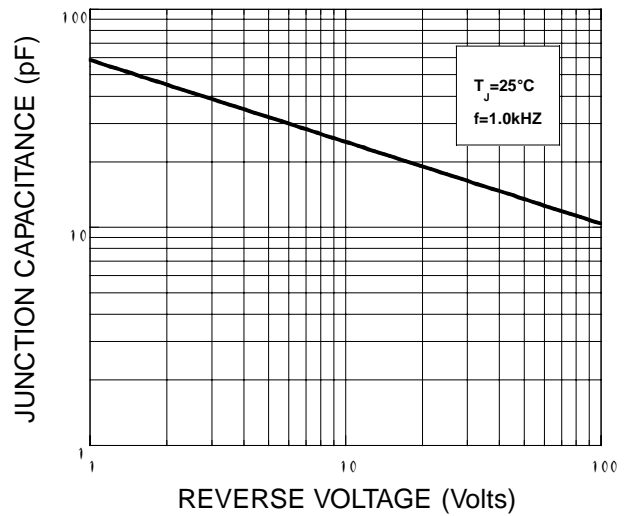
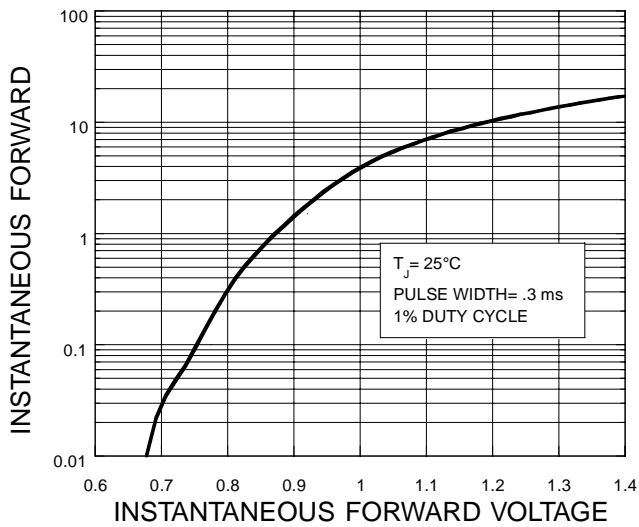
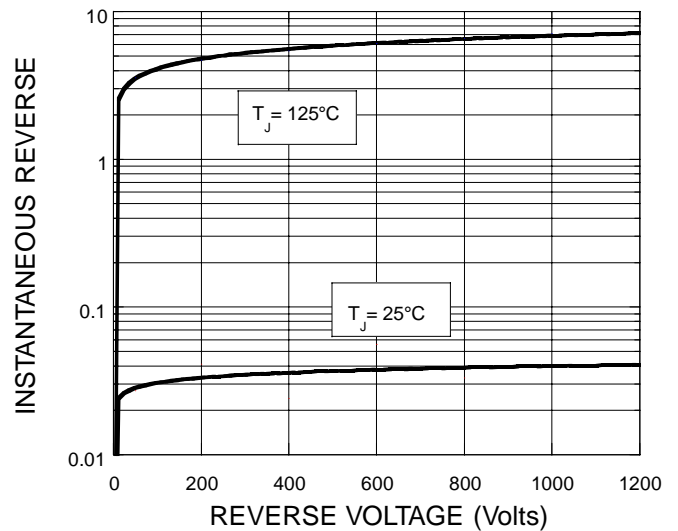
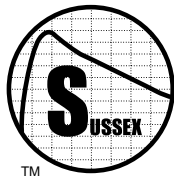


FIGURE 3A - TYPICAL FORWARD



**FIGURE 4A - TYPICAL REVERSE
VOLTAGE CHARACTERISTICS PER LEG**

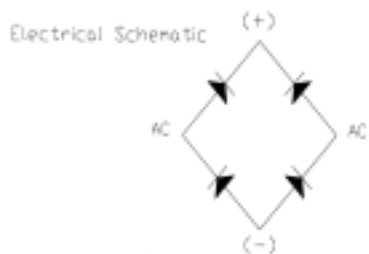
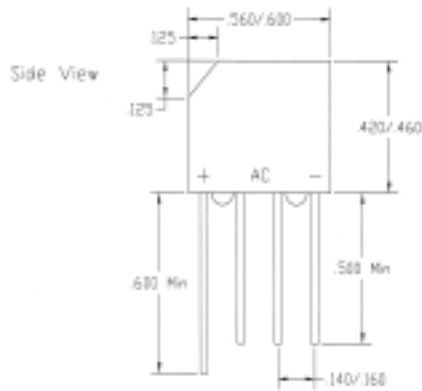




SUSSEX
SEMICONDUCTOR, INC.

**2.0 AMP
BRIDGE RECTIFIERS**

12251 TOWNE LAKE DRIVE, FORT MYERS, FLORIDA, 33913 • TEL: (239) 768-6800 • FAX: (239) 768-6868



All Dimensions In Inches

SINGLE - PHASE IN-LINE BRIDGE RECTIFIER

REVERSE VOLTAGES - 50 TO 1000 VOLTS

FORWARD CURRENT - 2.0 AMPS

2.0 AMP IN-LINE BRIDGE RECTIFIER SPECIFICATIONS

- ◆ Plated Leads Guarantee Excellent Solderability
- ◆ Molded Plastic Case
- ◆ Typical Leakage Current Less Than .1μA
- ◆ Ideal For Printed Circuit Boards
- ◆ Polarity Indicated By Solvent Resistant Marking
- ◆ Operating Temperature: -50 to 150°C
- ◆ Storage Temperature: -50 to 150°C
- ◆ High Isolation Resistance From Case To Leads

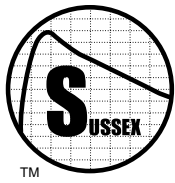
TABLE 1A - STANDARD DEVICE ELECTRICAL SPECIFICATIONS (NOTE 1)

SUSSEX PART NUMBER	MAX. AVERAGE FORWARD RECTIFIED OUTPUT CURRENT T _{CASE} =55 °C AMPS	MAX. INSTANTANEOUS FORWARD VOLTAGE PER BRIDGE ELEMENT		MAX. LEAKAGE CURRENT I _R @ V _{DC}		PEAK FORWARD SURGE CURRENT (NOTE 2) AMPS	MAX. RECURRENT PEAK REVERSE VOLTAGE (V _{RRM}) VOLTS	MAX. RMS INPUT VOLTAGE (V _{RMS}) VOLTS
		FORWARD VOLTAGE TEST CURRENT (I _F) AMPS	PEAK FORWARD VOLTAGE @ I _F VOLTS	V _{DC} VOLTS	I _R μA			
BDG-R2.0-50	2.0	3.1	1.1	50	5	60	50	35
BDG-R2.0-100	2.0	3.1	1.1	100	5	60	100	70
BDG-R2.0-200	2.0	3.1	1.1	200	5	60	200	140
BDG-R2.0-400	2.0	3.1	1.1	400	5	60	400	280
BDG-R2.0-600	2.0	3.1	1.1	600	5	60	600	420
BDG-R2.0-800	2.0	3.1	1.1	800	5	60	800	560
BDG-R2.0-1000	2.0	3.1	1.1	1000	5	60	1000	700

NOTES

NOTE 1 ◆ ELECTRICAL CHARACTERISTICS MEASURED AT 25°C UNLESS OTHERWISE STATED.

NOTE 2 ◆ PEAK FORWARD SURGE CURRENT MEASURED FROM A SINGLE SINE-WAVE BEING SUPERIMPOSED ON THE RATED LOAD (JEDEC METHOD).



SUSSEX SEMICONDUCTOR, INC.

12251 TOWNE LAKE DRIVE, FORT MYERS, FLORIDA, 33913 • TEL: (239) 768-6800 • FAX: (239) 768-6868

2.0 AMP BRIDGES - CONTINUED

FIGURE 1A - BRIDGE RECTIFIER
DERATING CURVE

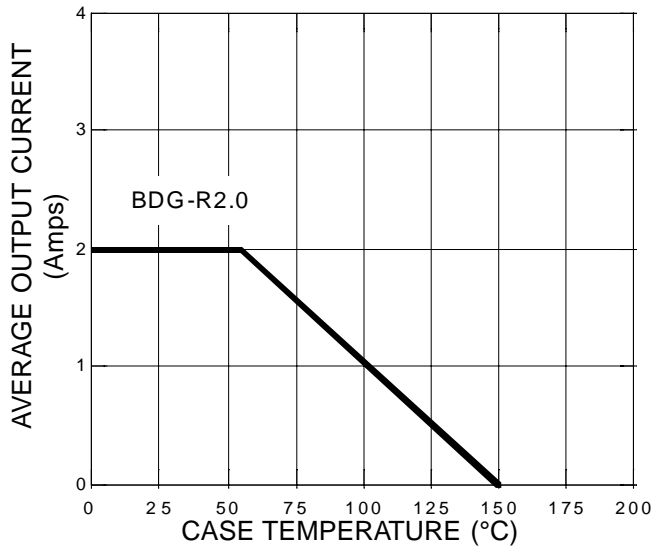


FIGURE 2A - TYPICAL JUNCTION
CAPACITANCE PER LEG

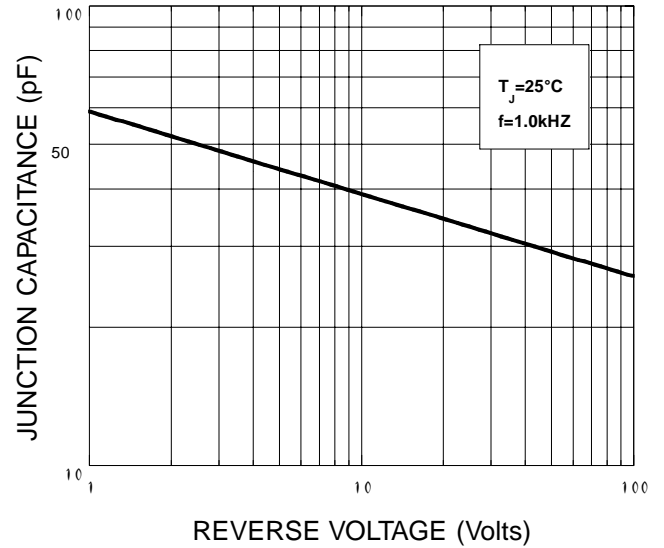


FIGURE 3A - TYPICAL INSTANTANEOUS
FORWARD CHARACTERISTICS PER LEG

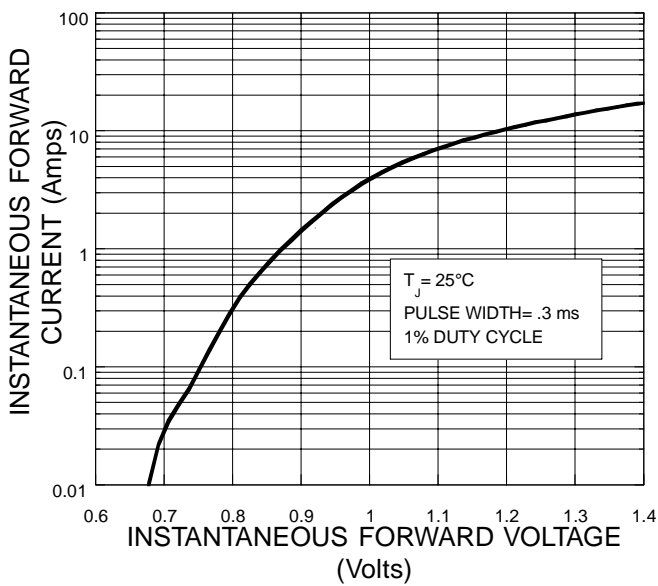
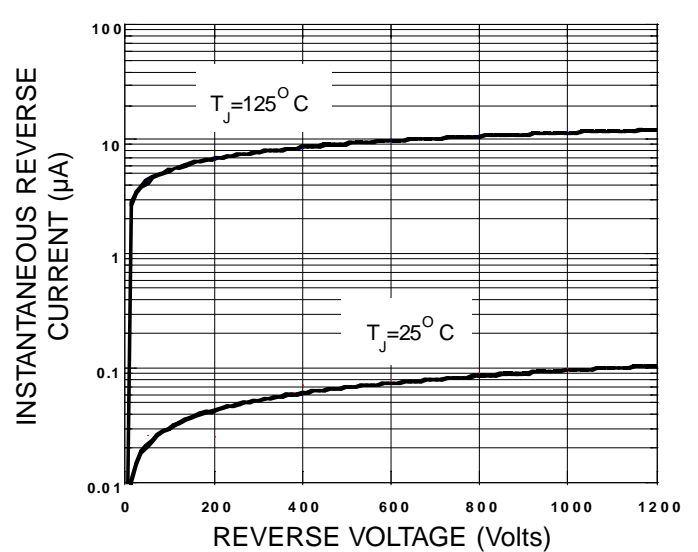
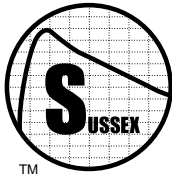


FIGURE 4A - TYPICAL REVERSE
VOLTAGE CHARACTERISTICS

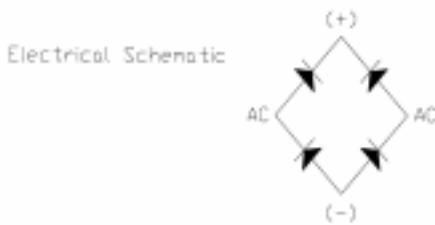
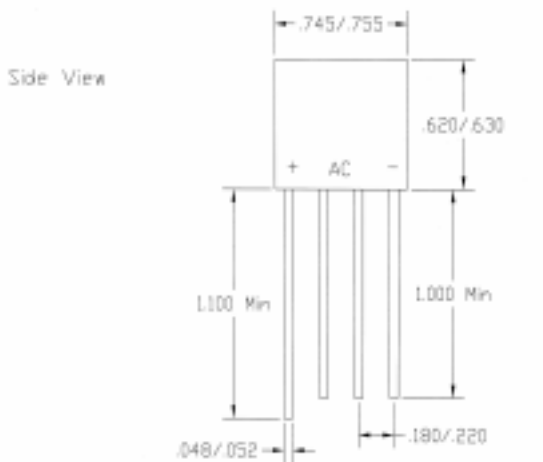




SUSSEX
SEMICONDUCTOR, INC.

**4.0 AMP
BRIDGE RECTIFIERS**

12251 TOWNE LAKE DRIVE, FORT MYERS, FLORIDA, 33913 • TEL: (239) 768-6800 • FAX: (239) 768-6868



All Dimensions In Inches

SINGLE - PHASE IN-LINE BRIDGE RECTIFIER

REVERSE VOLTAGES - 50 TO 1000 VOLTS

FORWARD CURRENT - 4.0 AMPS

4.0 AMP IN-LINE BRIDGE RECTIFIER SPECIFICATIONS

- ◆ Plated Leads Guarantee Excellent Solderability
- ◆ Molded Plastic Case
- ◆ Typical Leakage Current Less Than .1 μ A
- ◆ Ideal For Printed Circuit Boards
- ◆ Polarity Indicated By Solvent Resistant Marking
- ◆ Operating Temperature: -50 to 150°C
- ◆ Storage Temperature: -50 to 150°C
- ◆ High Isolation Resistance From Case To Leads

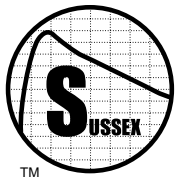
TABLE 1A - STANDARD DEVICE ELECTRICAL SPECIFICATIONS (NOTE 1)

SUSSEX PART NUMBER	MAX. AVERAGE FORWARD RECTIFIED OUTPUT CURRENT $T_{CASE}=55^{\circ}C$ AMPS	MAX. INSTANTANEOUS FORWARD VOLTAGE PER BRIDGE ELEMENT		MAX. LEAKAGE CURRENT $I_R @ V_{DC}$		PEAK FORWARD SURGE CURRENT (NOTE 2) AMPS	MAX. RECURRENT PEAK REVERSE VOLTAGE (V_{RRM}) VOLTS	MAX. RMS INPUT VOLTAGE (V_{RMS}) VOLTS
		FORWARD VOLTAGE TEST CURRENT (I_F) AMPS	PEAK FORWARD VOLTAGE @ I_F VOLTS	V_{DC} VOLTS	I_R μA			
BDG-R4.0-50	4.0	4.0	1.1	50	5	200	50	35
BDG-R4.0-100	4.0	4.0	1.1	100	5	200	100	70
BDG-R4.0-200	4.0	4.0	1.1	200	5	200	200	140
BDG-R4.0-400	4.0	4.0	1.1	400	5	200	400	280
BDG-R4.0-600	4.0	4.0	1.1	600	5	200	600	420
BDG-R4.0-800	4.0	4.0	1.1	800	5	200	800	560
BDG-R4.0-1000	4.0	4.0	1.1	1000	5	200	1000	700

NOTES

NOTE 1 ◆ ELECTRICAL CHARACTERISTICS MEASURED AT 25°C UNLESS OTHERWISE STATED.

NOTE 2 ◆ PEAK FORWARD SURGE CURRENT MEASURED FROM A SINGLE SINE-WAVE BEING SUPERIMPOSED ON THE RATED LOAD (JEDEC METHOD).

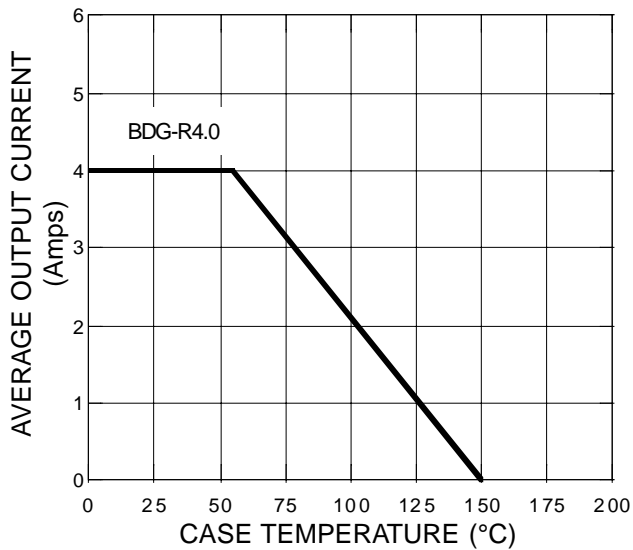


SUSSEX
SEMICONDUCTOR, INC.

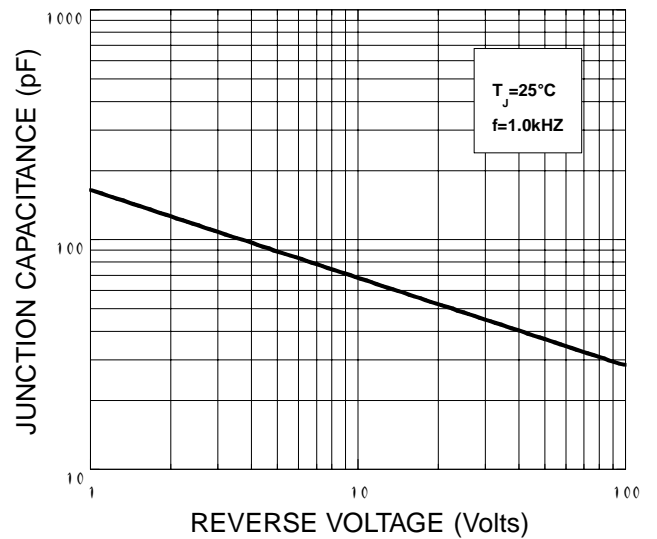
12251 TOWNE LAKE DRIVE, FORT MYERS, FLORIDA, 33913 • TEL: (239) 768-6800 • FAX: (239) 768-6868

**4.0 AMP
BRIDGES - CONTINUED**

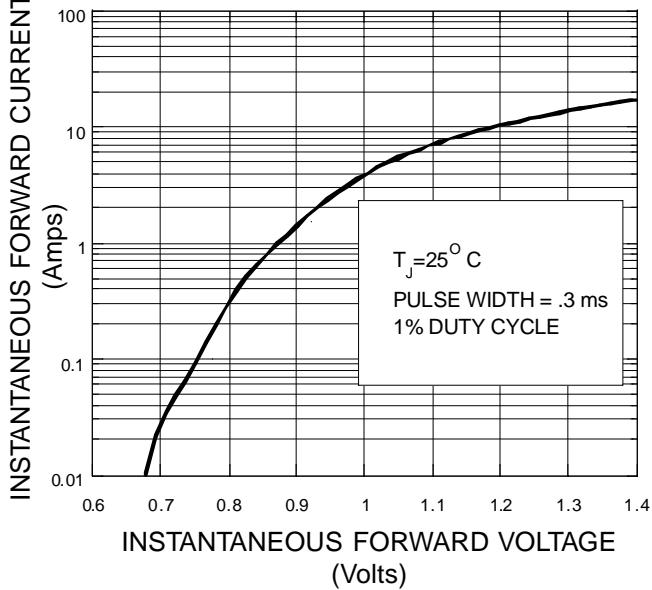
**FIGURE 1A - BRIDGE RECTIFIER
DERATING CURVE**



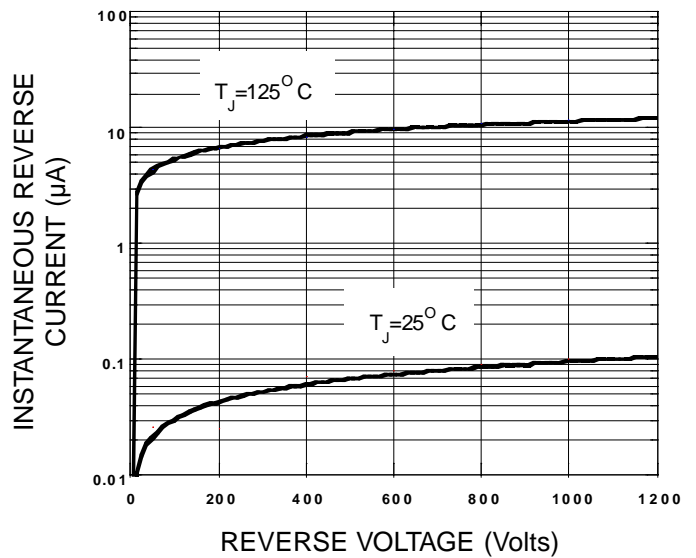
**FIGURE 2A - TYPICAL JUNCTION
CAPACITANCE PER LEG**

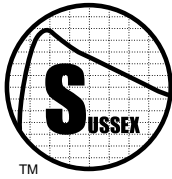


**FIGURE 3A - TYPICAL INSTANTANEOUS
FORWARD CHARACTERISTICS PER LEG**



**FIGURE 4A - TYPICAL REVERSE
VOLTAGE CHARACTERISTICS**

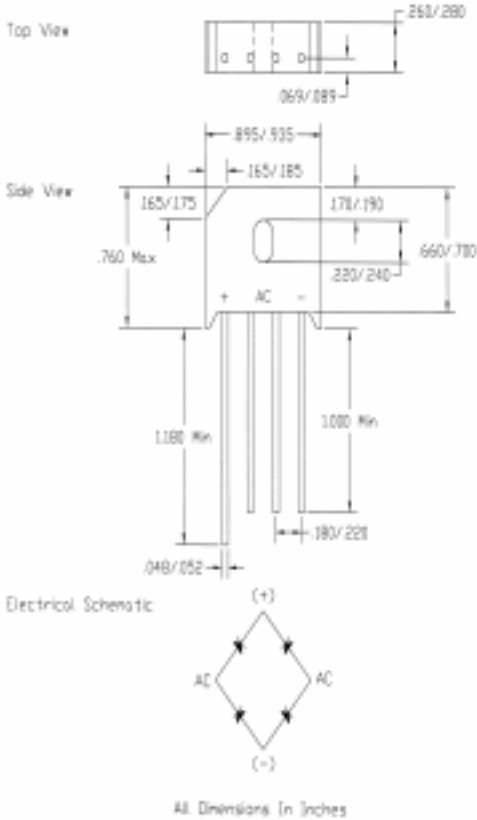




SUSSEX
SEMICONDUCTOR, INC.

**6.0 AND 8.0 AMP
BRIDGE RECTIFIERS**

12251 TOWNE LAKE DRIVE, FORT MYERS, FLORIDA, 33913 • TEL: (239) 768-6800 • FAX: (239) 768-6868



SINGLE - PHASE IN-LINE BRIDGE RECTIFIER

REVERSE VOLTAGES - 50 TO 1000 VOLTS

FORWARD CURRENT - 6.0 TO 8.0 AMPS

6.0 AND 8.0 AMP IN-LINE BRIDGE RECTIFIER SPECIFICATIONS

- ◆ Plated Leads Guarantee Excellent Solderability
- ◆ Molded Plastic Case
- ◆ Typical Leakage Current Less Than .1 μ A
- ◆ Ideal For Printed Circuit Boards
- ◆ Polarity Indicated By Solvent Resistant Marking
- ◆ Operating Temperature: -50 to 150°C
- ◆ Storage Temperature: -50 to 150°C
- ◆ High Isolation Resistance From Case To Leads

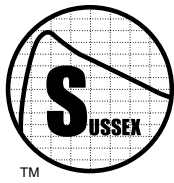
TABLE 1A - STANDARD DEVICE ELECTRICAL SPECIFICATIONS (NOTE 1)

SUSSEX PART NUMBER	MAX. AVERAGE FORWARD RECTIFIED OUTPUT CURRENT $T_{CASE}=55^{\circ}C$ AMPS	MAX. INSTANTANEOUS FORWARD VOLTAGE PER BRIDGE ELEMENT		MAX. LEAKAGE CURRENT $I_R @ V_{DC}$		PEAK FORWARD SURGE CURRENT (NOTE 2) AMPS	MAX. RECURRENT PEAK REVERSE VOLTAGE (V_{RRM}) VOLTS	MAX. RMS INPUT VOLTAGE (V_{RMS}) VOLTS
		FORWARD VOLTAGE TEST CURRENT (I_F) AMPS	PEAK FORWARD VOLTAGE @ I_F VOLTS	V_{DC} VOLTS	I_R μA			
BDG-R6.0-50	6.0	6.0	1.0	50	5	250	50	35
BDG-R6.0-100	6.0	6.0	1.0	100	5	250	100	70
BDG-R6.0-200	6.0	6.0	1.0	200	5	250	200	140
BDG-R6.0-400	6.0	6.0	1.0	400	5	250	400	280
BDG-R6.0-600	6.0	6.0	1.0	600	5	250	600	420
BDG-R6.0-800	6.0	6.0	1.0	800	5	250	800	560
BDG-R6.0-1000	6.0	6.0	1.0	1000	5	250	1000	700
BDG-R8.0-50	8.0	8.0	1.0	50	5	300	50	35
BDG-R8.0-100	8.0	8.0	1.0	100	5	300	100	70
BDG-R8.0-200	8.0	8.0	1.0	200	5	300	200	140
BDG-R8.0-400	8.0	8.0	1.0	400	5	300	400	280
BDG-R8.0-600	8.0	8.0	1.0	600	5	300	600	420
BDG-R8.0-800	8.0	8.0	1.0	800	5	300	800	560
BDG-R8.0-1000	8.0	8.0	1.0	1000	5	300	1000	700

NOTES

NOTE 1 ◆ ELECTRICAL CHARACTERISTICS MEASURED AT 25°C UNLESS OTHERWISE STATED.

NOTE 2 ◆ PEAK FORWARD SURGE CURRENT MEASURED FROM A SINGLE SINE-WAVE BEING SUPERIMPOSED ON THE

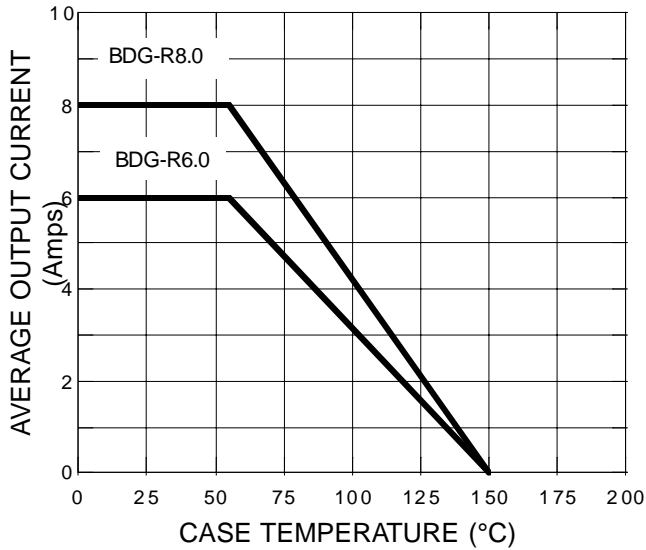


SUSSEX
SEMICONDUCTOR, INC.

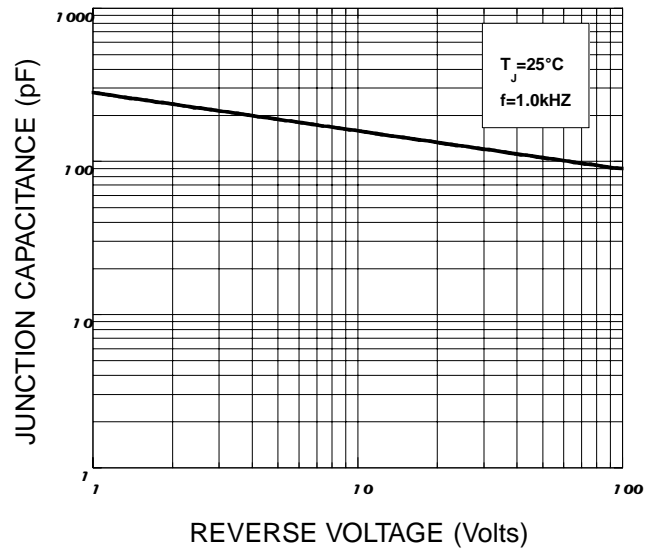
12251 TOWNE LAKE DRIVE, FORT MYERS, FLORIDA, 33913 • TEL: (239) 768-6800 • FAX: (239) 768-6868

**6.0 AND 8.0 AMP
BRIDGES - CONTINUED**

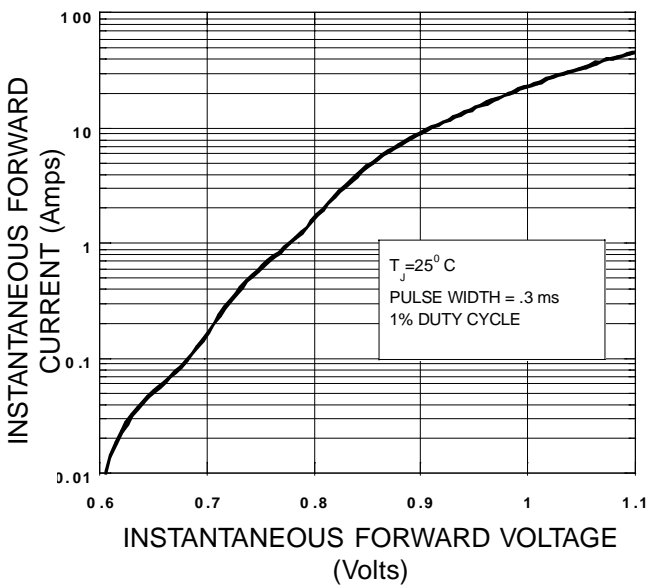
**FIGURE 1A - BRIDGE RECTIFIER
DERATING CURVE**



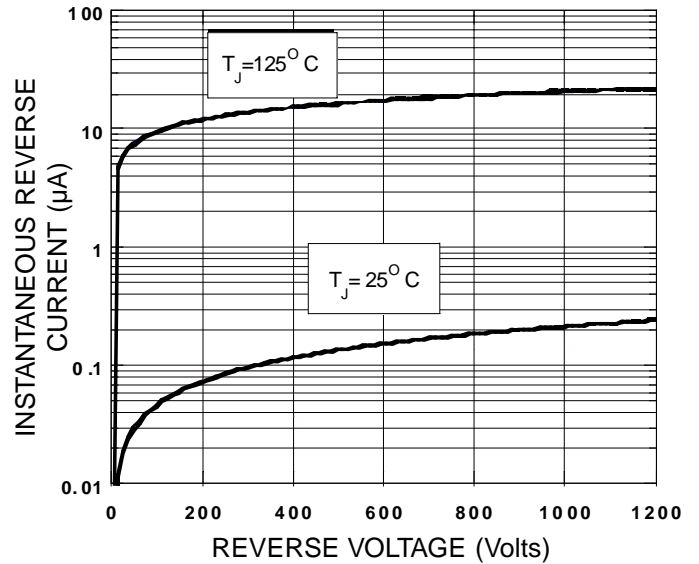
**FIGURE 2A - TYPICAL JUNCTION
CAPACITANCE PER LEG**

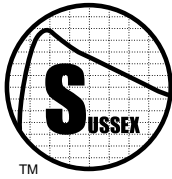


**FIGURE 3A - TYPICAL INSTANTANEOUS
FORWARD CHARACTERISTICS PER LEG**



**FIGURE 4A - TYPICAL REVERSE
VOLTAGE CHARACTERISTICS**

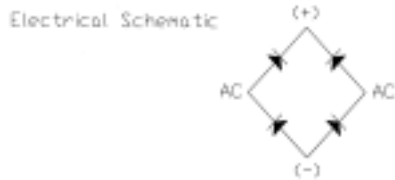
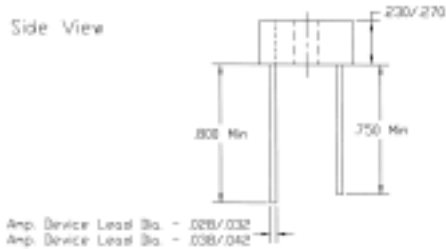
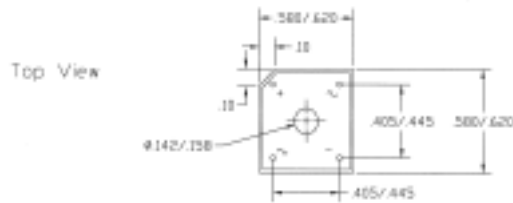




SUSSEX
SEMICONDUCTOR, INC.

**3.0 AND 6.0 AMP
BRIDGE RECTIFIERS**

12251 TOWNE LAKE DRIVE, FORT MYERS, FLORIDA, 33913 • TEL: (239) 768-6800 • FAX: (239) 768-6868



All Dimensions In Inches

SINGLE - PHASE BRIDGE RECTIFIER

REVERSE VOLTAGES - 50 TO 1000 VOLTS

FORWARD CURRENT - 3.0 TO 6.0 AMPS

3.0 AND 6.0 AMP BRIDGE RECTIFIER SPECIFICATIONS

- ◆ Plated Leads Guarantee Excellent Solderability
- ◆ Encapsulated In An Epoxy Filled Plastic Case
- ◆ Typical Leakage Current Less Than .1 μ A
- ◆ Ideal For Printed Circuit Boards
- ◆ Polarity Indicated By Solvent Resistant Marking
- ◆ Operating Temperature: -50 to 150°C
- ◆ Storage Temperature: -50 to 150°C

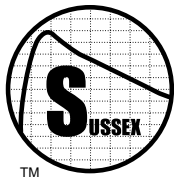
TABLE 1A - STANDARD DEVICE ELECTRICAL SPECIFICATIONS (NOTE 1)

SUSSEX PART NUMBER	MAX. AVERAGE FORWARD RECTIFIED OUTPUT CURRENT $T_{CASE}=55^{\circ}C$ AMPS	MAX. INSTANTANEOUS FORWARD VOLTAGE PER BRIDGE ELEMENT		MAX. LEAKAGE CURRENT $I_R @ V_{DC}$		PEAK FORWARD SURGE CURRENT (NOTE 2) AMPS	MAX. RECURRENT PEAK REVERSE VOLTAGE (V_{RRM}) VOLTS	MAX. RMS INPUT VOLTAGE (V_{RMS}) VOLTS
		FORWARD VOLTAGE TEST CURRENT (I_F) AMPS	PEAK FORWARD VOLTAGE @ I_F VOLTS	V_{DC} VOLTS	I_R μA			
BDG-SL3.0-50	3.0	1.5	1.0	50	5	60	50	35
BDG-SL3.0-100	3.0	1.5	1.0	100	5	60	100	70
BDG-SL3.0-200	3.0	1.5	1.0	200	5	60	200	140
BDG-SL3.0-400	3.0	1.5	1.0	400	5	60	400	280
BDG-SL3.0-600	3.0	1.5	1.0	600	5	60	600	420
BDG-SL3.0-800	3.0	1.5	1.0	800	5	60	800	560
BDG-SL3.0-1000	3.0	1.5	1.0	1000	5	60	1000	700
BDG-SL6.0-50	6.0	3.0	1.0	50	5	175	50	35
BDG-SL6.0-100	6.0	3.0	1.0	100	5	175	100	70
BDG-SL6.0-200	6.0	3.0	1.0	200	5	175	200	140
BDG-SL6.0-400	6.0	3.0	1.0	400	5	175	400	280
BDG-SL6.0-600	6.0	3.0	1.0	600	5	175	600	420
BDG-SL6.0-800	6.0	3.0	1.0	800	5	175	800	560
BDG-SL6.0-1000	6.0	3.0	1.0	1000	5	175	1000	700

NOTES

NOTE 1 ◆ ELECTRICAL CHARACTERISTICS MEASURED AT 25°C UNLESS OTHERWISE STATED.

NOTE 2 ◆ PEAK FORWARD SURGE CURRENT MEASURED FROM A SINGLE SINE-WAVE BEING SUPERIMPOSED ON THE RATED LOAD (JEDEC METHOD).



SUSSEX

SEMICONDUCTOR, INC.

12251 TOWNE LAKE DRIVE, FORT MYERS, FLORIDA, 33913 • TEL: (239) 768-6800 • FAX: (239) 768-6868

3.0 AND 6.0 AMP BRIDGES - CONTINUED

FIGURE 1A - BRIDGE RECTIFIER DERATING CURVE

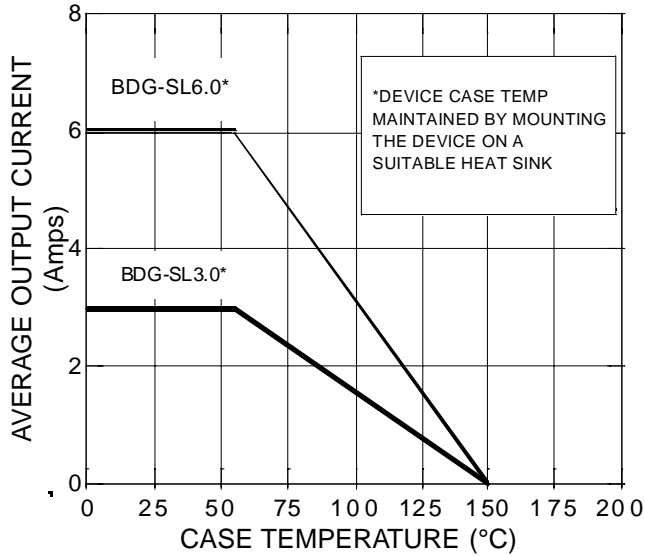


FIGURE 2A - TYPICAL JUNCTION CAPACITANCE PER LEG

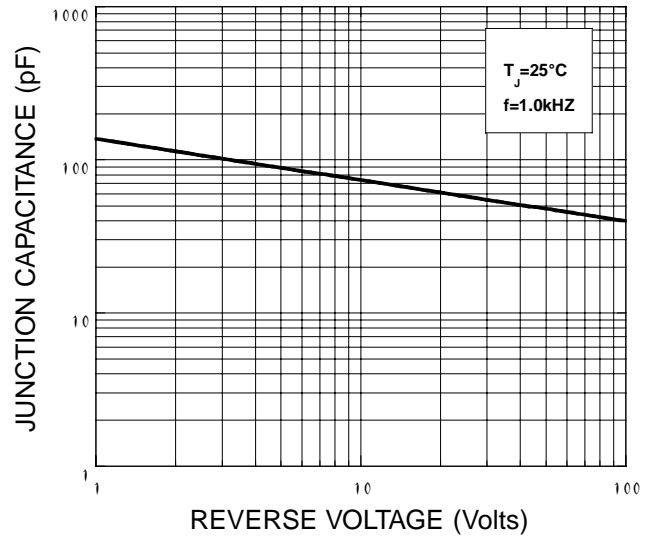


FIGURE 3A - TYPICAL INSTANTANEOUS FORWARD CHARACTERISTICS PER LEG

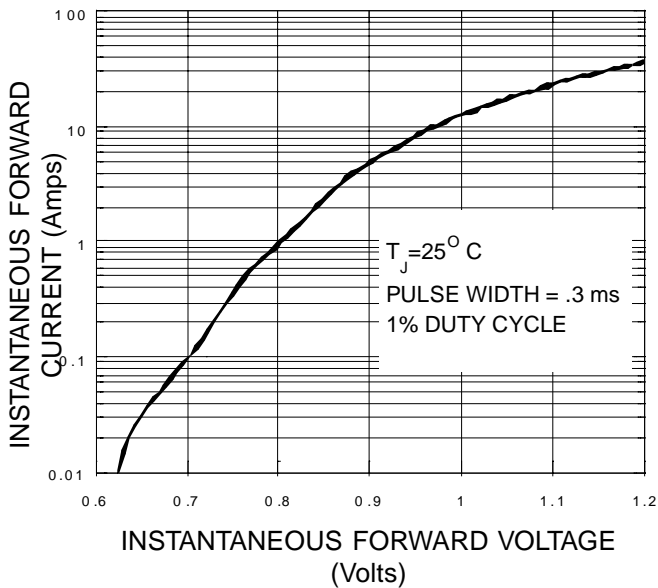
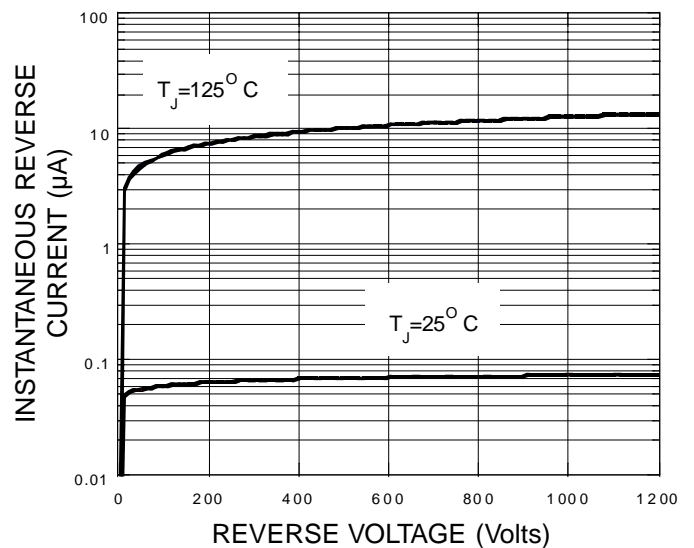
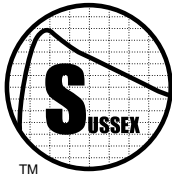


FIGURE 4A - TYPICAL REVERSE VOLTAGE CHARACTERISTICS

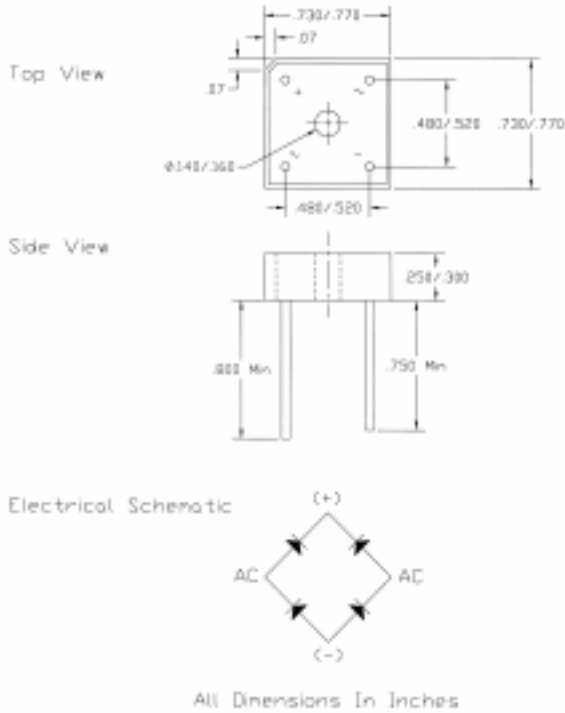




SUSSEX
SEMICONDUCTOR, INC.

**8.0 AND 10.0 AMP
BRIDGE RECTIFIERS**

12251 TOWNE LAKE DRIVE, FORT MYERS, FLORIDA, 33913 • TEL: (239) 768-6800 • FAX: (239) 768-6868



SINGLE - PHASE BRIDGE RECTIFIER

REVERSE VOLTAGES - 50 TO 1000 VOLTS

FORWARD CURRENT - 8.0 TO 10.0 AMPS

**8.0 AND 10.0 AMP BRIDGE
RECTIFIER
SPECIFICATIONS**

- ◆ Plated Leads Guarantee Excellent Solderability
- ◆ Encapsulated In An Epoxy Filled Plastic Case
- ◆ Typical Leakage Current Less Than .1 μ A
- ◆ Ideal For Printed Circuit Boards
- ◆ Polarity Indicated By Solvent Resistant Marking
- ◆ Operating Temperature: -50 to 150°C
- ◆ Storage Temperature: -50 to 150°C
- ◆ High Isolation Resistance From Case To Leads

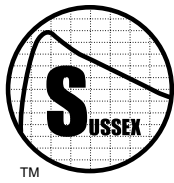
TABLE 1A - STANDARD DEVICE ELECTRICAL SPECIFICATIONS (NOTE 1)

SUSSEX PART NUMBER	MAX. AVERAGE FORWARD RECTIFIED OUTPUT CURRENT T _{CASE} =55 °C AMPS	MAX. INSTANTANEOUS FORWARD VOLTAGE PER BRIDGE ELEMENT		MAX. LEAKAGE CURRENT I _R @ V _{DC}		PEAK FORWARD SURGE CURRENT (NOTE 2) AMPS	MAX. RECURRENT PEAK REVERSE VOLTAGE (V _{RRM}) VOLTS	MAX. RMS INPUT VOLTAGE (V _{RMS}) VOLTS
		FORWARD VOLTAGE TEST CURRENT (I _F) AMPS	PEAK FORWARD VOLTAGE @ I _F VOLTS	V _{DC} VOLTS	I _R μ A			
BDG-SL8.0-50	8.0	8.0	1.1	50	10	200	50	35
BDG-SL8.0-100	8.0	8.0	1.1	100	10	200	100	70
BDG-SL8.0-200	8.0	8.0	1.1	200	10	200	200	140
BDG-SL8.0-400	8.0	8.0	1.1	400	10	200	400	280
BDG-SL8.0-600	8.0	8.0	1.1	600	10	200	600	420
BDG-SL8.0-800	8.0	8.0	1.1	800	10	200	800	560
BDG-SL8.0-1000	8.0	8.0	1.1	1000	10	200	1000	700
BDG-SL10.0-50	10.0	10.0	1.1	50	10	200	50	35
BDG-SL10.0-100	10.0	10.0	1.1	100	10	200	100	70
BDG-SL10.0-200	10.0	10.0	1.1	200	10	200	200	140
BDG-SL10.0-400	10.0	10.0	1.1	400	10	200	400	280
BDG-SL10.0-600	10.0	10.0	1.1	600	10	200	600	420
BDG-SL10.0-800	10.0	10.0	1.1	800	10	200	800	560
BDG-SL10.0-1000	10.0	10.0	1.1	1000	10	200	1000	700

NOTES

NOTE 1 ◆ ELECTRICAL CHARACTERISTICS MEASURED AT 25°C UNLESS OTHERWISE STATED.

NOTE 2 ◆ PEAK FORWARD SURGE CURRENT MEASURED FROM A SINGLE SINE-WAVE BEING SUPERIMPOSED ON THE RATED LOAD (JEDEC METHOD).



SUSSEX SEMICONDUCTOR, INC.

12251 TOWNE LAKE DRIVE, FORT MYERS, FLORIDA, 33913 • TEL: (239) 768-6800 • FAX: (239) 768-6868

8.0 AND 10.0 AMP BRIDGES - CONTINUED

FIGURE 1A - BRIDGE RECTIFIER
DERATING CURVE

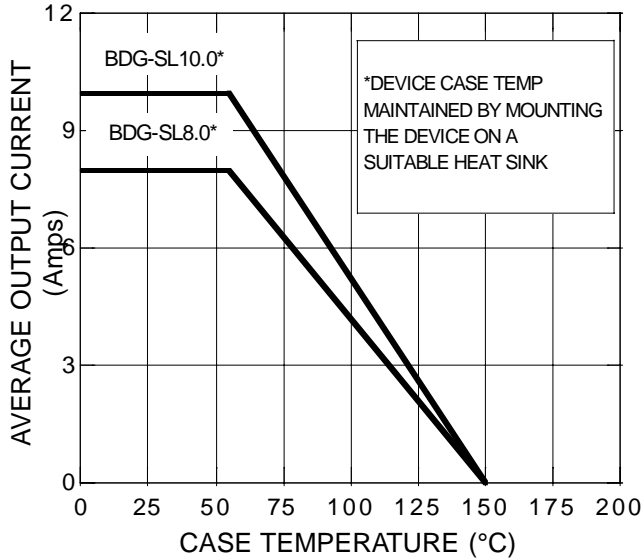


FIGURE 2A - TYPICAL JUNCTION
CAPACITANCE PER LEG

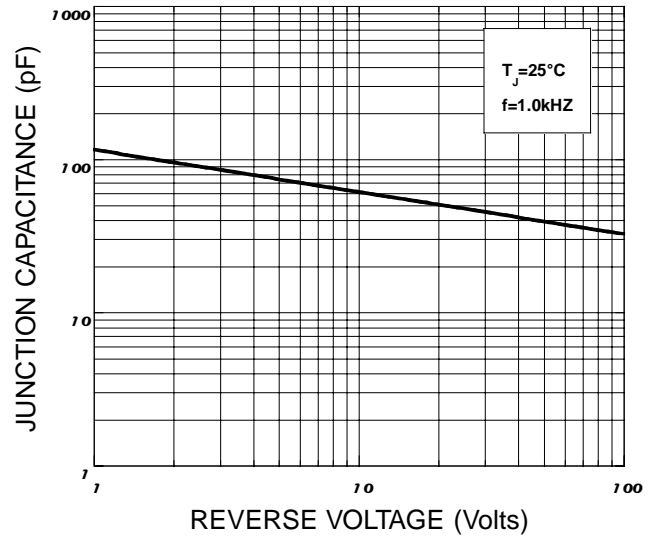


FIGURE 3A - TYPICAL FORWARD
CHARACTERISTICS PER LEG

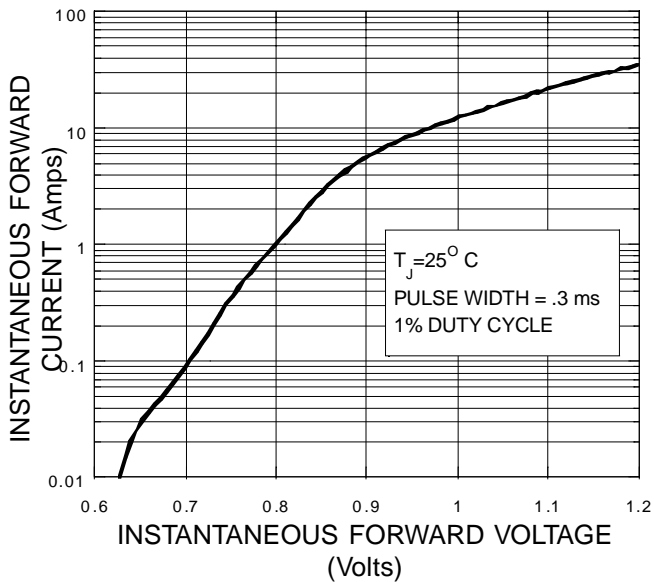
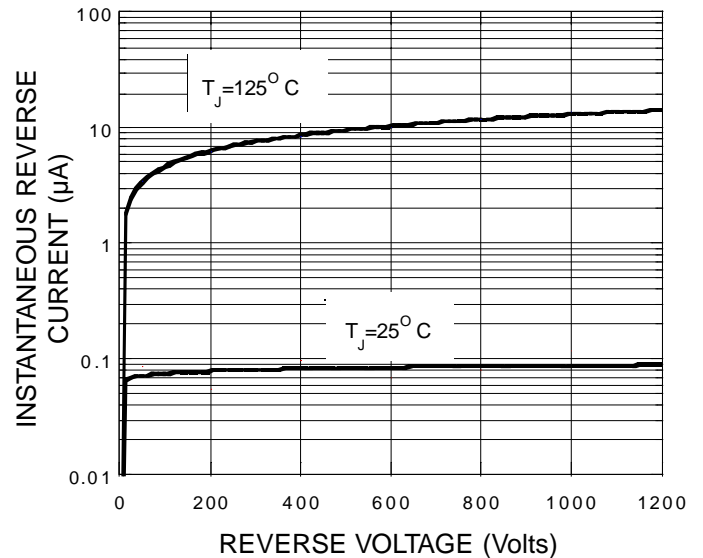
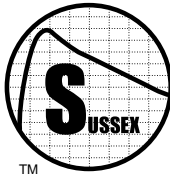


FIGURE 4A - TYPICAL REVERSE
VOLTAGE CHARACTERISTICS PER LEG

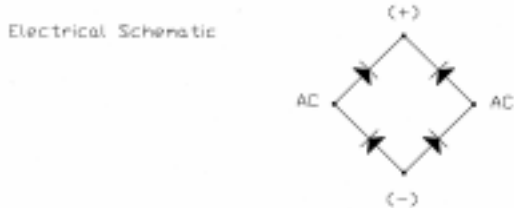
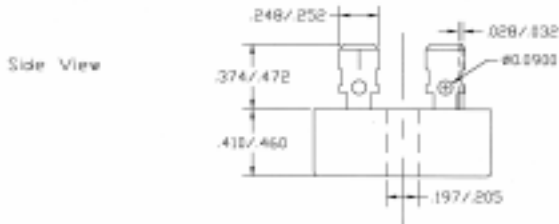
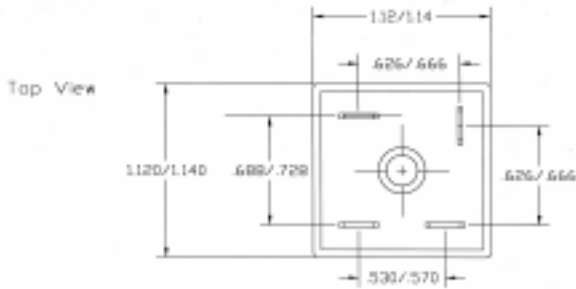




SUSSEX
SEMICONDUCTOR, INC.

**15 AMP
BRIDGE RECTIFIERS**

12251 TOWNE LAKE DRIVE, FORT MYERS, FLORIDA, 33913 • TEL: (239) 768-6800 • FAX: (239) 768-6868



All Dimensions In Inches

GLASS PASSIVATED SINGLE-PHASE BRIDGE

REVERSE VOLTAGES - 50 TO 1000 VOLTS

FORWARD CURRENT - 15 AMPS

**15 AMP BRIDGE RECTIFIER
DEVICE SPECIFICATIONS**

- ◆ High Current Silicon Standard Recovery Bridge Rectifiers
- ◆ Universal Four- Way Terminals Designed With .250 Female Quick Connect
- ◆ Each Device Individually Inspected
- ◆ Polarity Indicated by Solvent Resistant Marking on each Package
- ◆ Each Device Encapsulated on a Heat Sink
- ◆ Operating and Storage Temperature: -50 to +150 °C
- ◆ Maximum Thermal Resistance 1.2° C/W
- ◆ Isolation Resistance From Case to Leads 2500 VAC Min

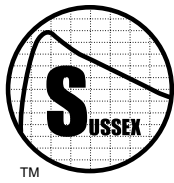
TABLE 1A - STANDARD DEVICE ELECTRICAL SPECIFICATIONS (NOTE 1)

SUSSEX PART NUMBER	MAX. AVERAGE FORWARD RECTIFIED OUTPUT CURRENT T _{CASE} =55 °C AMPS	MAX. INSTANTANEOUS FORWARD VOLTAGE PER BRIDGE ELEMENT		MAX. LEAKAGE CURRENT I _R @ V _{DC}		PEAK FORWARD SURGE CURRENT (NOTE 2) AMPS	MAX. RECURRENT PEAK REVERSE VOLTAGE (V _{RRM}) VOLTS	MAX. RMS INPUT VOLTAGE (V _{RMS}) VOLTS
		FORWARD VOLTAGE TEST CURRENT (I _F) AMPS	PEAK FORWARD VOLTAGE @ I _F VOLTS	V _{DC} VOLTS	I _R μA			
BDG-ST15.0-50	15	7.5	1.2	50	10	300	50	35
BDG-ST15.0-100	15	7.5	1.2	100	10	300	100	70
BDG-ST15.0-200	15	7.5	1.2	200	10	300	200	140
BDG-ST15.0-400	15	7.5	1.2	400	10	300	400	280
BDG-ST15.0-600	15	7.5	1.2	600	10	300	600	420
BDG-ST15.0-800	15	7.5	1.2	800	10	300	800	560
BDG-ST15.0-1000	15	7.5	1.2	1000	10	300	1000	700

NOTES

NOTE 1 ◆ ELECTRICAL CHARACTERISTICS MEASURED AT 25°C UNLESS OTHERWISE STATED.

NOTE 2 ◆ PEAK FORWARD SURGE CURRENT MEASURED FROM A SINGLE SINE-WAVE BEING SUPERIMPOSED ON THE RATED LOAD (JEDEC METHOD).

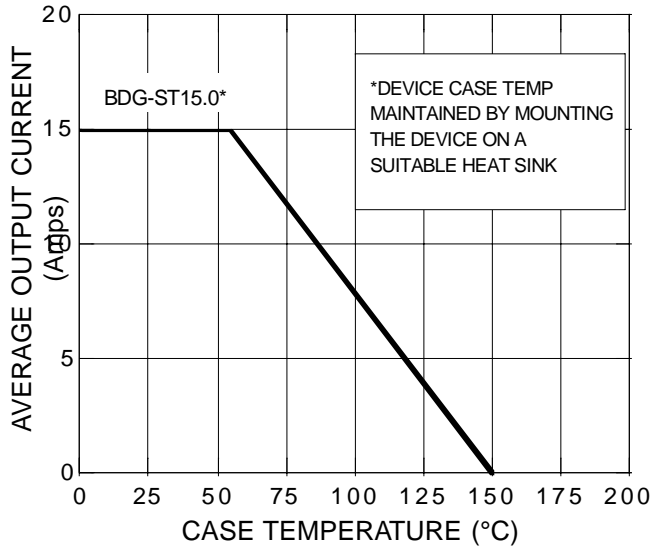


SUSSEX
SEMICONDUCTOR, INC.

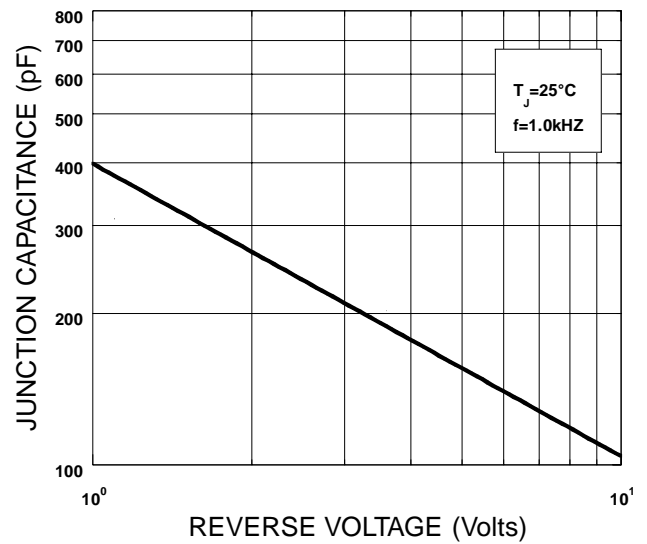
12251 TOWNE LAKE DRIVE, FORT MYERS, FLORIDA, 33913 • TEL: (239) 768-6800 • FAX: (239) 768-6868

**15 AMP
BRIDGES - CONTINUED**

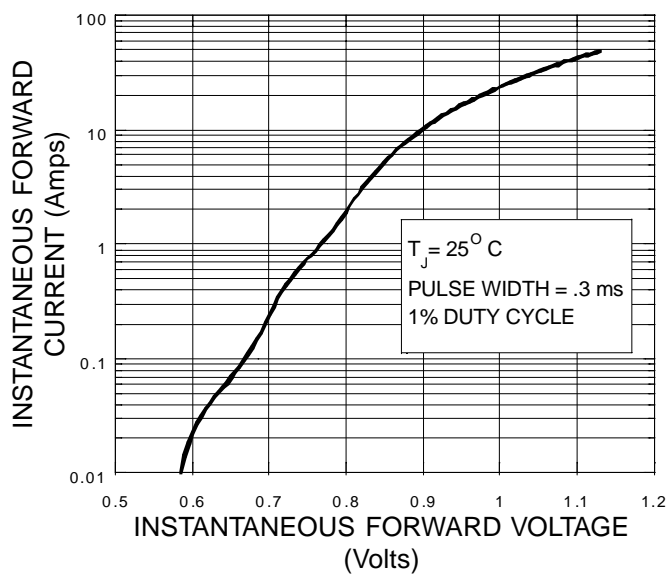
**FIGURE 1A - BRIDGE RECTIFIER
DERATING CURVE**



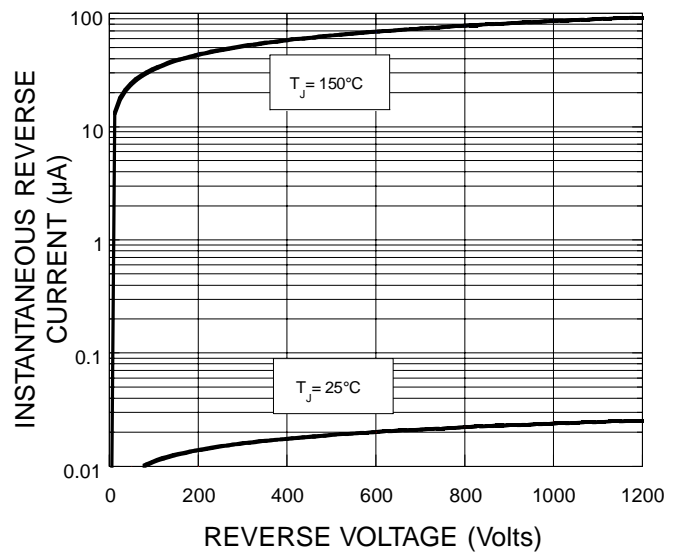
**FIGURE 2A - TYPICAL JUNCTION
CAPACITANCE PER LEG**

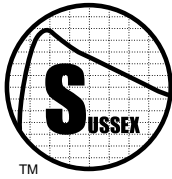


**FIGURE 3A - TYPICAL FORWARD
CHARACTERISTICS PER LEG**



**FIGURE 4A - TYPICAL REVERSE
CHARACTERISTICS PER LEG**

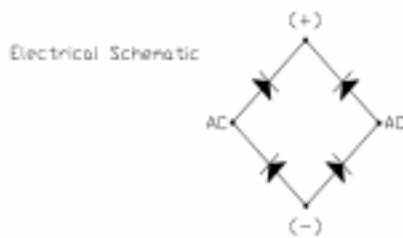
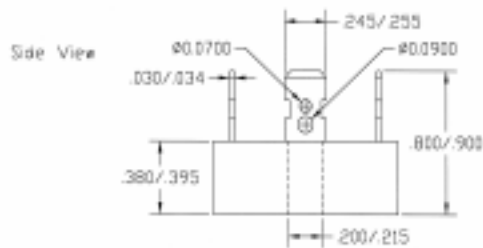
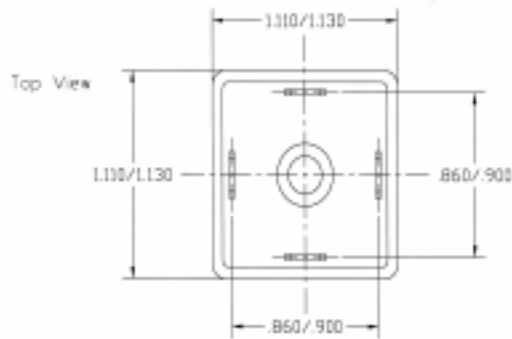




SUSSEX
SEMICONDUCTOR, INC.

**25-35 AMP
BRIDGE RECTIFIERS**

12251 TOWNE LAKE DRIVE, FORT MYERS, FLORIDA, 33913 • TEL: (239) 768-6800 • FAX: (239) 768-6868



ALL DIMENSIONS IN INCHES

GLASS PASSIVATED SINGLE-PHASE BRIDGE RECTIFIER

REVERSE VOLTAGES - 50 TO 1000 VOLTS

FORWARD CURRENT - 25 TO 35 AMPS

**25 TO 35 AMP BRIDGE
RECTIFIER
DEVICE SPECIFICATIONS**

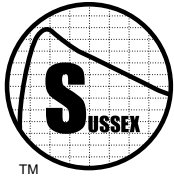
- ◆ High Current Silicon Standard Recovery Bridge Rectifiers
- ◆ Universal Four- Way Terminals Designed With .250 Female Quick Connect
- ◆ Each Device Individually Inspected
- ◆ Polarity Indicated by Solvent Resistant Marking on Each Package
- ◆ Each Device Encapsulated on a Heat Sink
- ◆ Operating and Storage Temperature: -50 to +150 °C
- ◆ Maximum Thermal Resistance 1.2° C/W
- ◆ Isolation Resistance From Case to Leads 2500 VAC

SUSSEX PART NUMBER	MAX. AVERAGE FORWARD RECTIFIED OUTPUT CURRENT T _{CASE} =55 °C AMPS	MAX. INSTANTANEOUS FORWARD VOLTAGE PER BRIDGE ELEMENT		MAX. LEAKAGE CURRENT I _R @ V _{DC}		PEAK FORWARD SURGE CURRENT (NOTE 2) AMPS	MAX. RECURRENT PEAK REVERSE VOLTAGE (V _{RRM}) VOLTS	MAX. RMS INPUT VOLTAGE (V _{RMS}) VOLTS
		FORWARD VOLTAGE TEST CURRENT (I _F) AMPS	PEAK FORWARD VOLTAGE @ I _F VOLTS	V _{DC} VOLTS	I _R μA			
BDG-ST25-50	25	12.5	1.2	50	10	300	50	35
BDG-ST25-100	25	12.5	1.2	100	10	300	100	70
BDG-ST25-200	25	12.5	1.2	200	10	300	200	140
BDG-ST25-400	25	12.5	1.2	400	10	300	400	280
BDG-ST25-600	25	12.5	1.2	600	10	300	600	420
BDG-ST25-800	25	12.5	1.2	800	10	300	800	560
BDG-ST25-1000	25	12.5	1.2	1000	10	300	1000	700
BDG-ST35-50	35	17.5	1.2	50	10	400	50	35
BDG-ST35-100	35	17.5	1.2	100	10	400	100	70
BDG-ST35-200	35	17.5	1.2	200	10	400	200	140
BDG-ST35-400	35	17.5	1.2	400	10	400	400	280
BDG-ST35-600	35	17.5	1.2	600	10	400	600	420
BDG-ST35-800	35	17.5	1.2	800	10	400	800	560
BDG-ST35-1000	35	17.5	1.2	1000	10	400	1000	700

NOTES

NOTE 1 ◆ ELECTRICAL CHARACTERISTICS MEASURED AT 25°C UNLESS OTHERWISE STATED.

NOTE 2 ◆ PEAK FORWARD SURGE CURRENT MEASURED FROM A SINGLE SINE-WAVE BEING SUPERIMPOSED ON THE RATED LOAD (JEDEC METHOD).



SUSSEX SEMICONDUCTOR, INC.

12251 TOWNE LAKE DRIVE, FORT MYERS, FLORIDA, 33913 • TEL: (239) 768-6800 • FAX: (239) 768-6868

25 - 35 AMP BRIDGES - CONTINUED

FIGURE 1A - BRIDGE RECTIFIER DERATING CURVE

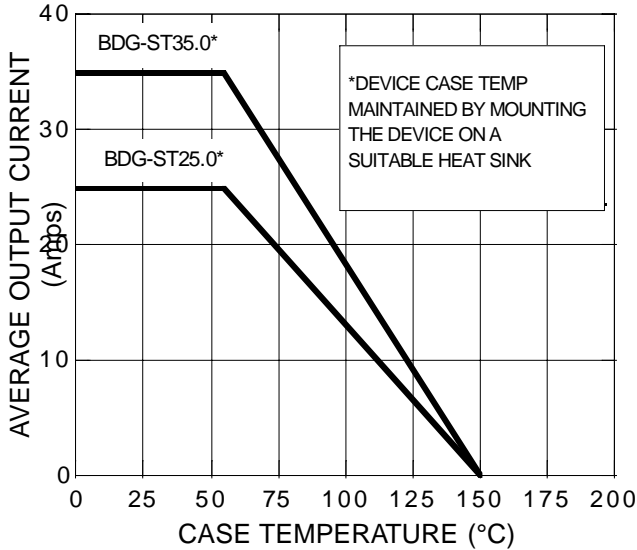


FIGURE 2A - TYPICAL JUNCTION CAPACITANCE PER LEG

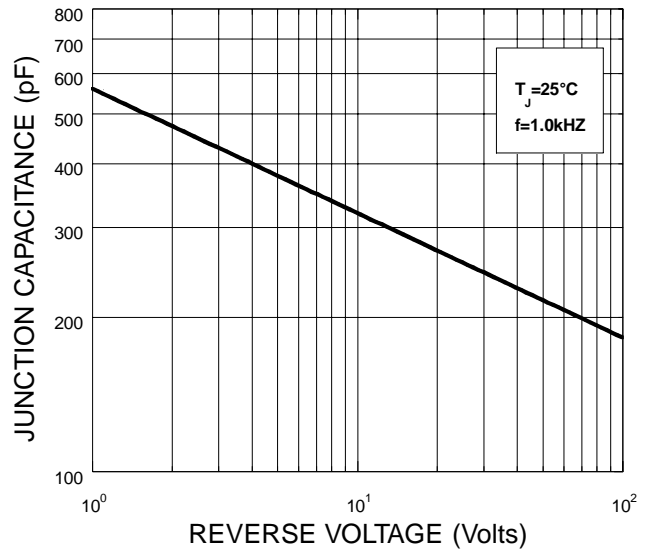


FIGURE 3A - TYPICAL FORWARD CHARACTERISTICS PER LEG

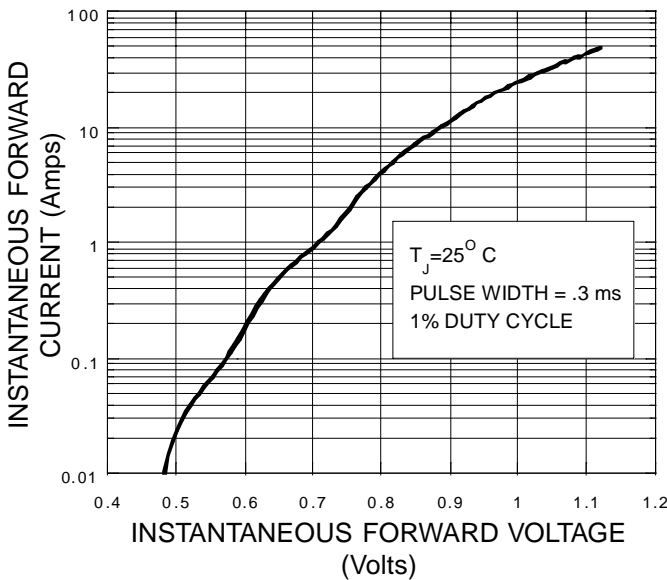


FIGURE 4A - TYPICAL REVERSE CHARACTERISTICS PER LEG

