

Features

- Attenuation: 1 dB steps to 15 dB
- Temperature Stability: ± 0.18 dB from -55°C to $+85^{\circ}\text{C}$ Typical
- Low DC Power Consumption
- Hermetic Surface Mount Package
- Integral TTL Driver
- 50 Ohms Nominal Impedance

Description

M/A-COM's AT-213 is a 4-bit, 1 dB step digital attenuator in a hermetically sealed ceramic 16-lead surface mount package. The AT-213 is ideally suited for use where high accuracy, fast switching, very low power consumption and low intermodulation products are required. Typical applications include dynamic range setting in a precision receiver circuits and other gain/leveling control circuits. Environmental screening is available. Contact the factory for information.

CR-11

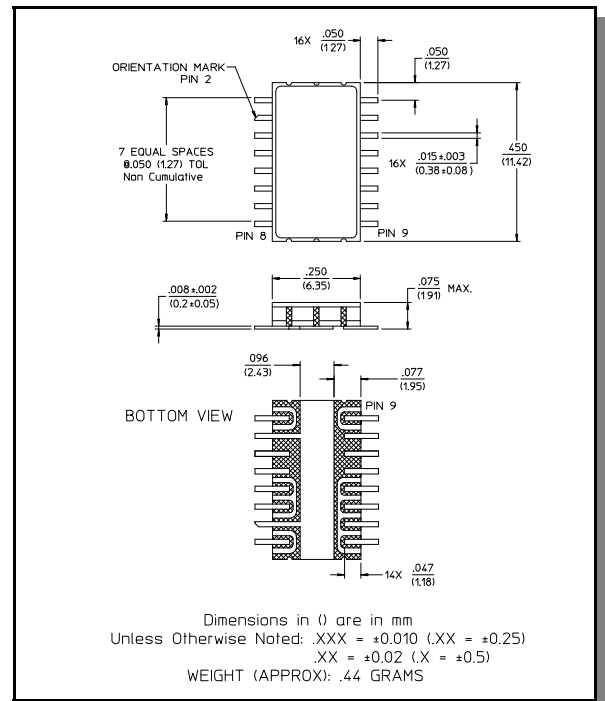

Electrical Specifications: $T_A = -55^{\circ}\text{C}$ to $+85^{\circ}\text{C}$ ¹

Parameter	Test Conditions	Frequency	Units	Min	Typ	Max
Reference Insertion Loss	—	DC - 0.5 GHz	dB	—	—	1.7
		DC - 1.0 GHz	dB	—	—	1.9
		DC - 2.0 GHz	dB	—	—	2.2
		DC - 3.0 GHz	dB	—	—	2.5
Attenuation Accuracy ²	Any Single Bit	DC - 2.0 GHz DC - 3.0 GHz	$\pm (0.15 \text{ dB} + 3\% \text{ of atten setting in dB})$ dB $\pm (0.2 \text{ dB} + 3\% \text{ of atten setting in dB})$ dB Or ± 0.4 dB, whichever is greater			
	Any Combination of Bits	DC - 2.0 GHz DC - 3.0 GHz	$\pm (0.2 \text{ dB} + 3\% \text{ of atten setting in dB})$ dB $\pm (0.2 \text{ dB} + 3\% \text{ of atten setting in dB})$ dB Or ± 0.4 dB, whichever is greater			
VSWR	—	—	Ratio	—	—	1.6:1
Trise, Tfall	10% to 90%	—	ns	—	9	—
Ton, Toff	50% Control to 90%/10% RF	—	ns	—	40	—
Transients	In-Band (peak-peak)	—	mV	—	30	—
1 dB Compression	Input Power Input Power	0.05 GHz	dBm	—	+22	—
		0.5 - 3.0 GHz	dBm	—	+28	—
Input IP3	For two-tone Input Power Up to +5 dBm	0.05 GHz	dBm	—	+40	—
		0.5 - 3.0 GHz	dBm	—	+50	—
Input IP2	For two-tone Input Power Up to +5 dBm	0.05 GHz	dBm	—	+45	—
		0.5 - 3.0 GHz	dBm	—	+68	—
Vcc	—	—	V	4.5	5.0	5.5
Vee	—	—	V	-8.0	—	-5.0

1. All specifications apply when operated with bias voltages of +5V for Vcc and -5.0V for Vee.
 2. This attenuator is guaranteed monotonic.

Electrical Specifications: $T_A = -55^{\circ}\text{C}$ to $+85^{\circ}\text{C}$

Parameter	Test Conditions	Frequency	Units	Min	Typ	Max
I _{cc}	V _{cc} = 4.5 to 5.5V V _{ctl} = 0 to 0.8V, or V _{cc} -2.1V to V _{cc}	—	mA	—	—	4.0
I _{ee}	V _{ee} = -5.0 to -8.0V	—	mA	—	—	1.0
V _{ctl}	Logic 0 (TTL)	—	V	0.0	—	0.8
V _{ctl}	Logic 1 (TTL)	—	V	2.0	—	5.0
Input Leakage Current (Low)	0 to 0.8V	—	μA	—	—	1.0
Input Leakage Current (High)	2.0 to 5.0V	—	μA	—	—	1.0

Absolute Maximum Ratings ³

Parameter	Absolute Maximum
Max Input Power 0.5 GHz 0.5 - 3.0 GHz	+27 dBm +34 dBm
Supply Voltages V _{cc} V _{ee}	+5.5V -8.5V
Control Voltage ⁴	-0.5V to V _{cc} +0.5V
Operating Temperature	-55°C to +125°C
Storage Temperature	-65°C to +150°C

- 3. Operation of this device above any one of these parameters may cause permanent damage.
- 4. Standard CMOS TTL interface, latch-up will occur if logic signal is applied prior to power supply.

Truth Table

Control Inputs				
C4	C3	C2	C1	Attenuation
0	0	0	0	Reference
0	0	0	1	1 dB
0	0	1	0	2 dB
0	1	0	0	4 dB
1	0	0	0	8 dB
1	1	1	1	15 dB

0 = TTL Low 1 = TTL High

Functional Schematic (Top View)

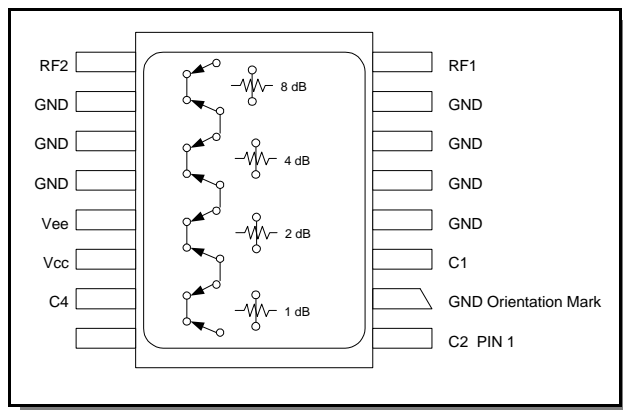

Specifications subject to change without notice.

- North America: Tel. (800) 366-2266
- Asia/Pacific: Tel.+81-44-844-8296, Fax +81-44-844-8298
- Europe: Tel. +44 (1344) 869 595, Fax+44 (1344) 300 020

Visit www.macom.com for additional data sheets and product information.

Typical Performance Curves

Ref. Insertion Loss vs. Frequency

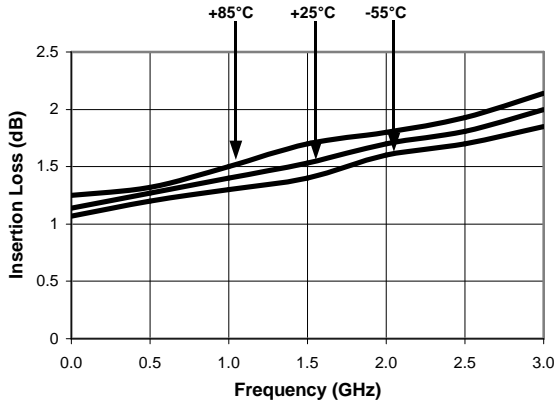

Attenuation Accuracy vs. Frequency

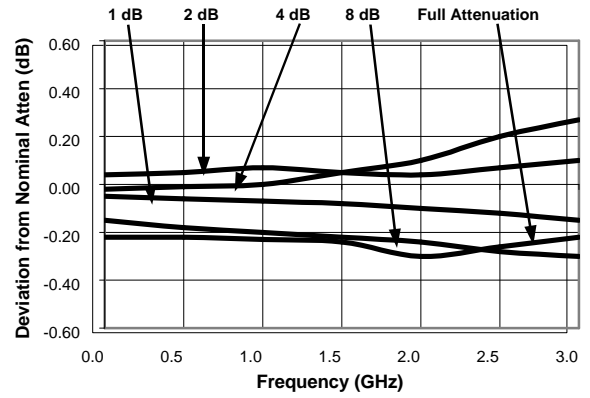

RF1 VSWR vs. Frequency

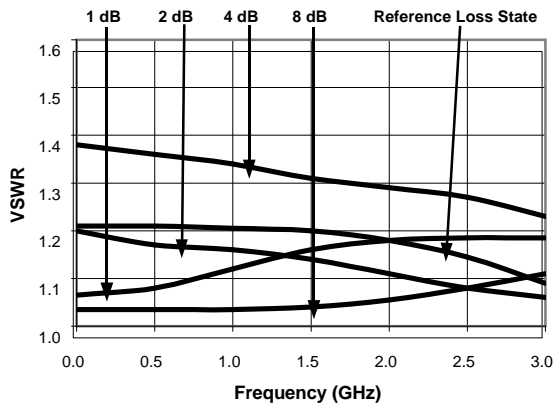

RF2 VSWR vs. Frequency

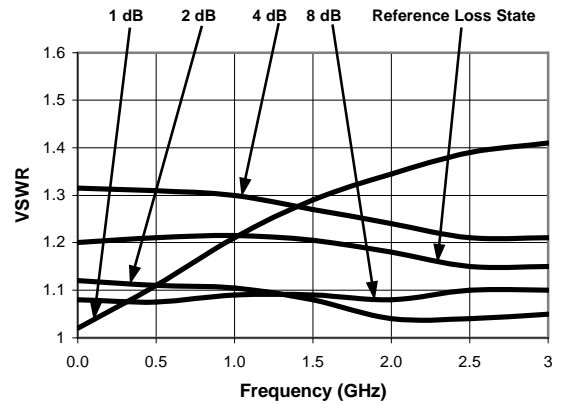

Ordering Information

Part Number	Package
AT-213 PIN	CR-11

Specifications subject to change without notice.

- North America: Tel. (800) 366-2266
- Asia/Pacific: Tel.+81-44-844-8296, Fax +81-44-844-8298
- Europe: Tel. +44 (1344) 869 595, Fax+44 (1344) 300 020

Visit www.macom.com for additional data sheets and product information.