



STS3DPFS30L

StripFET™ P - CHANNEL 30V - 0.13Ω - 3A S0-8 MOSFET PLUS SCHOTTKY RECTIFIER

PRELIMINARY DATA

MAIN PRODUCT CHARACTERISTICS			
MOSFET	V_{DSS}	$R_{DS(on)}$	I_D
	30V	<0.16Ω	3A
SCHOTTKY	$I_{F(AV)}$	V_{RRM}	$V_{F(MAX)}$
	3A	30V	0.51V

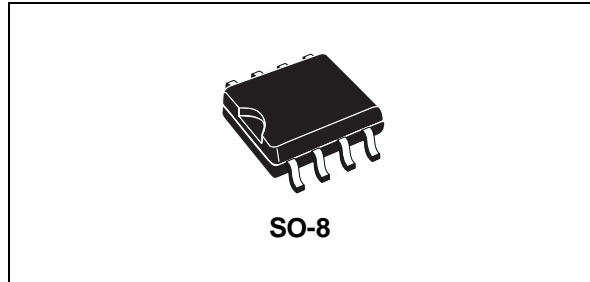

DESCRIPTION:

This product associates the latest low voltage StripFET™ in p-channel version to a low drop Schottky diode. Such configuration is extremely versatile in implementing, a large variety of DC-DC converters for printers, portable equipment, and cellular phones.

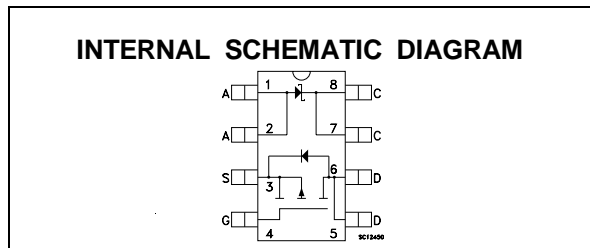

MOSFET ABSOLUTE MAXIMUM RATINGS

Symbol	Parameter	Value	Unit
V_{DS}	Drain-source Voltage ($V_{GS} = 0$)	30	V
V_{DGR}	Drain- gate Voltage ($R_{GS} = 20 \text{ k}\Omega$)	30	V
V_{GS}	Gate-source Voltage	± 20	V
I_D	Drain Current (continuous) at $T_c = 25 \text{ }^\circ\text{C}$	3	A
I_D	Drain Current (continuous) at $T_c = 100 \text{ }^\circ\text{C}$	1.9	A
$I_{DM}(\bullet)$	Drain Current (pulsed)	12	A
P_{tot}	Total Dissipation at $T_c = 25 \text{ }^\circ\text{C}$	2	W

SCHOTTKY ABSOLUTE MAXIMUM RATINGS

Symbol	Parameter		Value	Unit
V_{RRM}	Repetitive Peak Reverse Voltage		30	V
$I_{F(RMS)}$	RMS Forward Current		20	A
$I_{F(AV)}$	Average Forward Current	$T_L = 125 \text{ }^\circ\text{C}$ $\delta = 0.5$	3	A
I_{FSM}	Surge Non Repetitive Forward Current	$t_p = 10 \text{ ms}$ Sinusoidal	75	A
I_{RSM}	Non Repetitive Peak Reverse Current	$t_p = 100 \text{ }\mu\text{s}$	1	A
dv/dt	Critical Rate Of Rise Of Reverse Voltage		10000	V/ μs

(•) Pulse width limited by safe operating area

Note: For the P-CHANNEL MOSFET actual polarity of voltages and current has to be reversed

STS3DPFS30L

THERMAL DATA

R _{thj-amb}	(*)Thermal Resistance Junction-ambient MOSFET S.O. Dual Operating	78	°C/W
R _{thj-amb}	(*) Thermal Resistance Junction-ambientSCHOTTKY	62	°C/W
T _{stg}	Storage Temperature Range	100	°C/W
T _j	Junction Temperature	-65 to 150	°C
	(*) mounted on FR-4 board (steady state)	150	°C

MOSFET ELECTRICAL CHARACTERISTICS (T_{case} = 25 °C unless otherwise specified)

OFF

Symbol	Parameter	Test Conditions	Min.	Typ.	Max.	Unit
V _{(BR)DSS}	Drain-source Breakdown Voltage	I _D = 250 μA V _{GS} = 0	30			V
I _{DSS}	Zero Gate Voltage Drain Current (V _{GS} = 0)	V _{DS} = Max Rating V _{DS} = Max Rating T _c = 125 °C			1 10	μA μA
I _{GSS}	Gate-body Leakage Current (V _{DS} = 0)	V _{GS} = ± 16 V			± 1	μA

ON (*)

Symbol	Parameter	Test Conditions	Min.	Typ.	Max.	Unit
V _{GS(th)}	Gate Threshold Voltage	V _{DS} = V _{GS} I _D = 250 μA	1		2.5	V
R _{DS(on)}	Static Drain-source On Resistance	V _{GS} = 10V I _D = 1.5 A V _{GS} = 4.5V I _D = 1.5 A		0.13 0.15	0.16 0.19	Ω Ω
I _{D(on)}	On State Drain Current	V _{DS} > I _{D(on)} × R _{DS(on)max} V _{GS} = 10 V	3			A

DYNAMIC

Symbol	Parameter	Test Conditions	Min.	Typ.	Max.	Unit
g _{fs} (*)	Forward Transconductance	V _{DS} > I _{D(on)} × R _{DS(on)max} I _D = 1.5 A		3.5		S
C _{iss}	Input Capacitance	V _{DS} = 25 V f = 1 MHz V _{GS} = 0		510		pF
C _{oss}	Output Capacitance			170		pF
C _{rss}	Reverse Transfer Capacitance			55		pF

ELECTRICAL CHARACTERISTICS (continued)

SWITCHING ON

Symbol	Parameter	Test Conditions	Min.	Typ.	Max.	Unit
$t_{d(on)}$ t_r	Turn-on Delay Time Rise Time	$V_{DD} = 15\text{ V}$ $I_D = 1.5\text{ A}$ $R_G = 4.7\ \Omega$ $V_{GS} = 4.5\text{ V}$ (Resistive Load, see fig. 3)		15 37		ns ns
Q_g Q_{gs} Q_{gd}	Total Gate Charge Gate-Source Charge Gate-Drain Charge	$V_{DD} = 15\text{ V}$ $I_D = 3\text{ A}$ $V_{GS} = 4.5\text{ V}$		5.5 1.7 1.8	7.5	nC nC nC

SWITCHING OFF

Symbol	Parameter	Test Conditions	Min.	Typ.	Max.	Unit
$t_{d(off)}$ t_f	Turn-off Delay Time Fall Time	$V_{DD} = 15\text{ V}$ $I_D = 1.5\text{ A}$ $R_G = 4.7\ \Omega$ $V_{GS} = 4.5\text{ V}$ (Resistive Load, see fig. 3)		15 29		ns ns

SOURCE DRAIN DIODE

Symbol	Parameter	Test Conditions	Min.	Typ.	Max.	Unit
I_{SD} $I_{SDM}(\bullet)$	Source-drain Current Source-drain Current (pulsed)				3 12	A A
$V_{SD} (*)$	Forward On Voltage	$I_{SD} = 3\text{ A}$ $V_{GS} = 0$			2	V
t_{rr} Q_{rr} I_{RRM}	Reverse Recovery Time Reverse Recovery Charge Reverse Recovery Current	$I_{SD} = 3\text{ A}$ $di/dt = 100\text{ A}/\mu\text{s}$ $V_{DD} = 15\text{ V}$ $T_j = 150\text{ }^\circ\text{C}$ (see test circuit, figure 5)		18 12 1.33		ns nC A

(*) Pulsed: Pulse duration = 300 μs , duty cycle 1.5 %

(\bullet) Pulse width limited by safe operating area

SCHOTTKY STATIC ELECTRICAL CHARACTERISTICS

Symbol	Parameter	Test Conditions	Min.	Typ.	Max.	Unit
$I_R (*)$	Reversed Leakage Current	$T_J = 25\text{ }^\circ\text{C}$ $V_R = 30\text{ V}$ $T_J = 125\text{ }^\circ\text{C}$ $V_R = 30\text{ V}$		0.03	0.2 100	mA mA
$V_F (*)$	Forward Voltage drop	$T_J = 25\text{ }^\circ\text{C}$ $I_F = 3\text{ A}$ $T_J = 125\text{ }^\circ\text{C}$ $I_F = 3\text{ A}$		0.38	0.51 0.46	V V

SO-8 MECHANICAL DATA

DIM.	mm			inch		
	MIN.	TYP.	MAX.	MIN.	TYP.	MAX.
A			1.75			0.068
a1	0.1		0.25	0.003		0.009
a2			1.65			0.064
a3	0.65		0.85	0.025		0.033
b	0.35		0.48	0.013		0.018
b1	0.19		0.25	0.007		0.010
C	0.25		0.5	0.010		0.019
c1	45 (typ.)					
D	4.8		5.0	0.188		0.196
E	5.8		6.2	0.228		0.244
e		1.27			0.050	
e3		3.81			0.150	
F	3.8		4.0	0.14		0.157
L	0.4		1.27	0.015		0.050
M			0.6			0.023
S	8 (max.)					

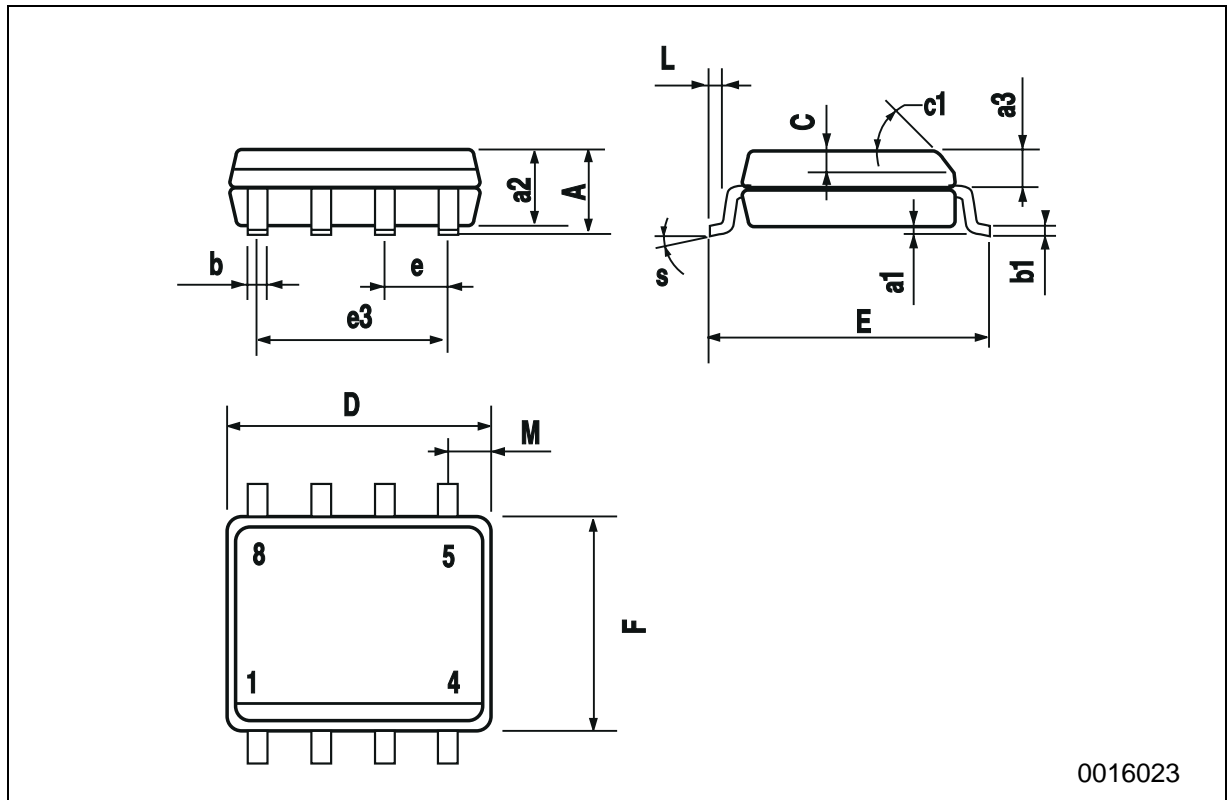

0016023

Information furnished is believed to be accurate and reliable. However, STMicroelectronics assumes no responsibility for the consequences of use of such information nor for any infringement of patents or other rights of third parties which may result from its use. No license is granted by implication or otherwise under any patent or patent rights of STMicroelectronics. Specification mentioned in this publication are subject to change without notice. This publication supersedes and replaces all information previously supplied. STMicroelectronics products are not authorized for use as critical components in life support devices or systems without express written approval of STMicroelectronics.

The ST logo is a trademark of STMicroelectronics

© 2000 STMicroelectronics – Printed in Italy – All Rights Reserved

STMicroelectronics GROUP OF COMPANIES

Australia - Brazil - China - Finland - France - Germany - Hong Kong - India - Italy - Japan - Malaysia - Malta - Morocco -
Singapore - Spain - Sweden - Switzerland - United Kingdom - U.S.A.

<http://www.st.com>