

# SSTU32864

1.8 V configurable registered buffer  
for DDR2 RDIMM applications

Rev. 01 — 12 July 2004

Objective data

## 1. Description

The SSTU32864 is a 25-bit 1:1 or 14-bit 1:2 configurable registered buffer designed for 1.7 V to 1.9 V  $V_{DD}$  operation.

All clock and data inputs are compatible with the JEDEC standard to SSTL\_18. The control inputs are LVCMOS. All outputs are 1.8 V CMOS drivers that have been optimized to drive the DDR2 DIMM load.

The SSTU32864 operates from a differential clock (CK and  $\overline{CK}$ ). Data are registered at the crossing of CK going HIGH, and  $\overline{CK}$  going LOW.

The C0 input controls the pinout configuration of the 1:2 pinout from A configuration (when LOW) to B configuration (when HIGH). The C1 input controls the pinout configuration from 25-bit 1:1 (when LOW) to 14-bit 1:2 (when HIGH).

The device supports low-power standby operation. When the reset input ( $\overline{RESET}$ ) is LOW, the differential input receivers are disabled, and undriven (floating) data, clock and reference voltage ( $V_{REF}$ ) inputs are allowed. In addition, when  $\overline{RESET}$  is LOW all registers are reset, and all outputs are forced LOW. The LVCMOS  $\overline{RESET}$  and Cn inputs must always be held at a valid logic HIGH or LOW level.

To ensure defined outputs from the register before a stable clock has been supplied,  $\overline{RESET}$  must be held in the LOW state during power-up.

In the DDR2 RDIMM application,  $\overline{RESET}$  is specified to be completely asynchronous with respect to CK and  $\overline{CK}$ . Therefore, no timing relationship can be guaranteed between the two. When entering reset, the register will be cleared and the data outputs will be driven LOW quickly, relative to the time to disable the differential input receivers. However, when coming out of reset, the register will become active quickly, relative to the time to enable the differential input receivers. As long as the data inputs are LOW, and the clock is stable during the time from the LOW-to-HIGH transition of  $\overline{RESET}$  until the input receivers are fully enabled, the design of the SSTU32864 must ensure that the outputs will remain LOW, thus ensuring no glitches on the output.

The device monitors both  $\overline{DCS}$  and  $\overline{CSR}$  inputs and will gate the Qn outputs from changing states when both  $\overline{DCS}$  and  $\overline{CSR}$  inputs are HIGH. If either  $\overline{DCS}$  or  $\overline{CSR}$  input is LOW, the Qn outputs will function normally. The  $\overline{RESET}$  input has priority over the  $\overline{DCS}$  and  $\overline{CSR}$  control and will force the outputs LOW. If the  $\overline{DCS}$ -control functionality is not desired, then the  $\overline{CSR}$  input can be hardwired to ground, in which case the setup time requirement for  $\overline{DCS}$  would be the same as for the other D data inputs.

The SSTU32864 is available in the LFBGA96 package.



**PHILIPS**

## 2. Features

- Configurable register supporting DDR2 Registered DIMM applications
- Configurable to 25-bit 1:1 mode or 14-bit 1:2 mode
- Controlled output impedance drivers enable optimal signal integrity and speed
- Exceeds JESD82-7 speed performance (1.8 ns max. single-bit switching propagation delay; 2.0 ns max. mass-switching)
- Supports up to 450 MHz clock frequency of operation
- Optimized pinout for high-density DDR2 module design
- Chip-selects minimize power consumption by gating data outputs from changing state
- Supports SSTL\_18 data inputs
- Differential clock (CK and  $\overline{CK}$ ) inputs
- Supports LVCMOS switching levels on the control and  $\overline{RESET}$  inputs
- Single 1.8 V supply operation
- Available in 96-ball, 13.5 × 5.5 mm, 0.8 mm ball pitch LFBGA package

## 3. Ordering information

**Table 1: Ordering information**

$T_{amb} = 0\text{ }^{\circ}\text{C}$  to  $+70\text{ }^{\circ}\text{C}$ .

Type number	Package			
	Name	Description	Solder process	Version
SSTU32864EC/G	LFBGA96	plastic low profile fine-pitch ball grid array package; 96 balls; body 13.5 × 5.5 × 1.05 mm	Pb-free (SnAgCu solder ball compound)	SOT536-1
SSTU32864EC	LFBGA96	plastic low profile fine-pitch ball grid array package; 96 balls; body 13.5 × 5.5 × 1.05 mm	SnPb solder ball compound	SOT536-1

## 4. Pinning information

### 4.1 Pinning

	1	2	3	4	5	6
A	DCKE	n.c.	V <sub>REF</sub>	V <sub>DD</sub>	QCKE	DNU
B	D2	D15	GND	GND	Q2	Q15
C	D3	D16	V <sub>DD</sub>	V <sub>DD</sub>	Q3	Q16
D	DODT	n.c.	GND	GND	QODT	DNU
E	D5	D17	V <sub>DD</sub>	V <sub>DD</sub>	Q5	Q17
F	D6	D18	GND	GND	Q6	Q18
G	n.c.	RESET	V <sub>DD</sub>	V <sub>DD</sub>	C1	C0
H	CK	D $\overline{\text{CS}}$	GND	GND	Q $\overline{\text{CS}}$	DNU
J	$\overline{\text{CK}}$	$\overline{\text{CSR}}$	V <sub>DD</sub>	V <sub>DD</sub>	ZOH	ZOL
K	D8	D19	GND	GND	Q8	Q19
L	D9	D20	V <sub>DD</sub>	V <sub>DD</sub>	Q9	Q20
M	D10	D21	GND	GND	Q10	Q21
N	D11	D22	V <sub>DD</sub>	V <sub>DD</sub>	Q11	Q22
P	D12	D23	GND	GND	Q12	Q23
R	D13	D24	V <sub>DD</sub>	V <sub>DD</sub>	Q13	Q24
T	D14	D25	V <sub>REF</sub>	V <sub>DD</sub>	Q14	Q25

002aaa955

Fig 1. Ball mapping; 1:1 register (C0 = 0, C1 = 0); top view.

## 1.8 V configurable registered buffer for DDR2 RDIMM applications

	1	2	3	4	5	6
A	DCKE	n.c.	V <sub>REF</sub>	V <sub>DD</sub>	QCKEA	QCKEB
B	D2	DNU	GND	GND	Q2A	Q2B
C	D3	DNU	V <sub>DD</sub>	V <sub>DD</sub>	Q3A	Q3B
D	DODT	n.c.	GND	GND	QODTA	QODTB
E	D5	DNU	V <sub>DD</sub>	V <sub>DD</sub>	Q5A	Q5B
F	D6	DNU	GND	GND	Q6A	Q6B
G	n.c.	RESET	V <sub>DD</sub>	V <sub>DD</sub>	C1	C0
H	CK	D $\overline{CS}$	GND	GND	Q $\overline{CS}$ A	Q $\overline{CS}$ B
J	$\overline{CK}$	$\overline{CSR}$	V <sub>DD</sub>	V <sub>DD</sub>	ZOH	ZOL
K	D8	DNU	GND	GND	Q8A	Q8B
L	D9	DNU	V <sub>DD</sub>	V <sub>DD</sub>	Q9A	Q9B
M	D10	DNU	GND	GND	Q10A	Q10B
N	D11	DNU	V <sub>DD</sub>	V <sub>DD</sub>	Q11A	Q11B
P	D12	DNU	GND	GND	Q12A	Q12B
R	D13	DNU	V <sub>DD</sub>	V <sub>DD</sub>	Q13A	Q13B
T	D14	DNU	V <sub>REF</sub>	V <sub>DD</sub>	Q14A	Q14B

002aaa956

Fig 2. Ball mapping; 1:2 register A (C0 = 0, C1 = 1); top view.

	1	2	3	4	5	6
A	D1	n.c.	V <sub>REF</sub>	V <sub>DD</sub>	Q1A	Q1B
B	D2	DNU	GND	GND	Q2A	Q2B
C	D3	DNU	V <sub>DD</sub>	V <sub>DD</sub>	Q3A	Q3B
D	D4	n.c.	GND	GND	Q4A	Q4B
E	D5	DNU	V <sub>DD</sub>	V <sub>DD</sub>	Q5A	Q5B
F	D6	DNU	GND	GND	Q6A	Q6B
G	n.c.	RESET	V <sub>DD</sub>	V <sub>DD</sub>	C1	C0
H	CK	D $\overline{CS}$	GND	GND	Q $\overline{CS}$ A	Q $\overline{CS}$ B
J	$\overline{CK}$	$\overline{CSR}$	V <sub>DD</sub>	V <sub>DD</sub>	ZOH	ZOL
K	D8	DNU	GND	GND	Q8A	Q8B
L	D9	DNU	V <sub>DD</sub>	V <sub>DD</sub>	Q9A	Q9B
M	D10	DNU	GND	GND	Q10A	Q10B
N	DODT	DNU	V <sub>DD</sub>	V <sub>DD</sub>	QODTA	QODTB
P	D12	DNU	GND	GND	Q12A	Q12B
R	D13	DNU	V <sub>DD</sub>	V <sub>DD</sub>	Q13A	Q13B
T	DCKE	DNU	V <sub>REF</sub>	V <sub>DD</sub>	QCKEA	QCKEB

002aaa957

Fig 3. Ball mapping; 1:2 register B (C0 = 1, C1 = 1); top view.

## 4.2 Pin description

**Table 2: Pin description**

Symbol	Description	Electrical characteristics
GND	Ground	ground input
V <sub>DD</sub>	Power supply voltage	1.8 V nominal
V <sub>REF</sub>	Input reference voltage	0.9 V nominal
Z <sub>OH</sub>	Reserved for future use	input
Z <sub>OL</sub>	Reserved for future use	input
CK	Positive master clock input	differential input
$\overline{CK}$	Negative master clock input	differential input
C0, C1	Configuration control inputs	LVC MOS inputs
$\overline{RESET}$	Asynchronous reset input. Resets registers and disables V <sub>REF</sub> data and clock differential-input receivers.	LVC MOS input
$\overline{CSR}$ , $\overline{DCS}$	Chip select inputs. Disables data outputs switching when both inputs are HIGH (see <a href="#">Table note [1]</a> ).	SSTL_18 input
D[1:25]	Data inputs. Clocked in on the crossing of the rising edge of CK and the falling edge of $\overline{CK}$ .	SSTL_18 input
DODT	The outputs of this register will not be suspended by $\overline{DCS}$ and $\overline{CSR}$ control.	SSTL_18 input
DCKE	The outputs of this register will not be suspended by $\overline{DCS}$ and $\overline{CSR}$ control.	SSTL_18 input
Q[1:25]	The outputs that are suspended by $\overline{DCS}$ and $\overline{CSR}$ control (see <a href="#">Table note [2]</a> ).	1.8 V CMOS
$\overline{QCS}$	Data outputs that will not be suspended by $\overline{DCS}$ and $\overline{CSR}$ control.	1.8 V CMOS
QODT	Data outputs that will not be suspended by $\overline{DCS}$ and $\overline{CSR}$ control.	1.8 V CMOS
QCKE	Data outputs that will not be suspended by $\overline{DCS}$ and $\overline{CSR}$ control.	1.8 V CMOS
n.c.	No-connect. Ball present but no internal connection to the die.	-
DNU	Do-not-use. Ball internally connected to the die which should be left open-circuit.	-

[1] Configurations:

Data inputs = D2, D3, D5, D6, D8-D25 when C0 = 0 and C1 = 0.

Data inputs = D2, D3, D5, D6, D8-D14 when C0 = 0 and C1 = 1.

Data inputs = D1-D6, D8-D10, D12, D13 when C0 = 1 and C1 = 1.

[2] Configurations:

Data outputs = Q2, Q3, Q5, Q6, Q8-Q25 when C0 = 0 and C1 = 0.

Data outputs = Q2, Q3, Q5, Q6, Q8-Q14 when C0 = 0 and C1 = 1.

Data outputs = Q1-Q6, Q8-Q10, Q12, Q13 when C0 = 1 and C1 = 1.

5. Functional description

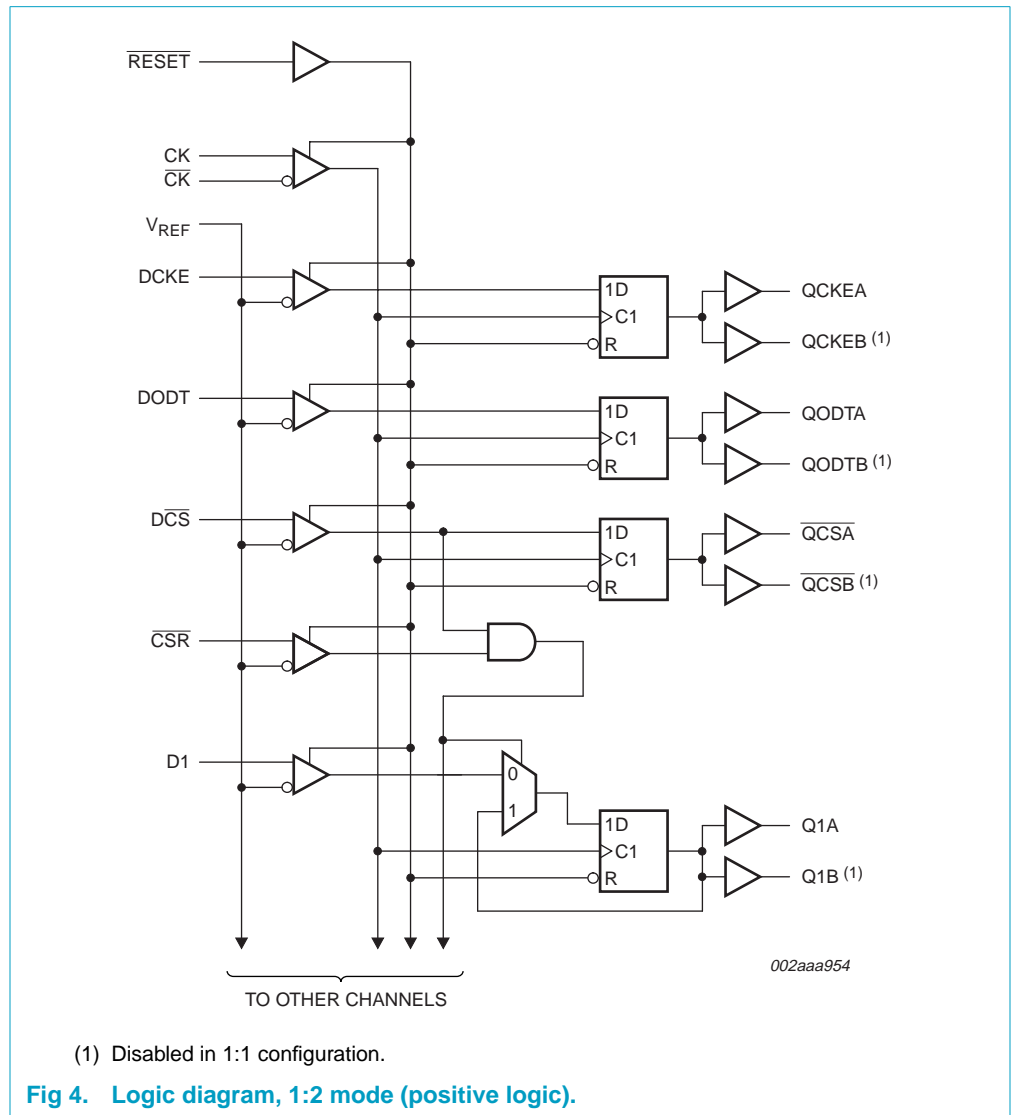

Table 3: Function table (each flip-flop)

Inputs						Outputs		
RESET	DCS	CSR	CK	CK	Dn, DODT, DCKE	Q	Q	Q
H	L	L	↑	↓	L	L	L	L
H	L	L	↑	↓	H	H	L	H
H	L	L	L or H	L or H	X	Qo	Qo	Qo
H	L	H	↑	↓	L	L	L	L
H	L	H	↑	↓	H	H	L	H
H	L	H	L or H	L or H	X	Qo	Qo	Qo
H	H	L	↑	↓	L	L	H	L
H	H	L	↑	↓	H	H	H	H
H	H	L	L or H	L or H	X	Qo	Qo	Qo
H	H	H	↑	↓	L	Qo	H	L
H	H	H	↑	↓	H	Qo	H	H
H	H	H	L or H	L or H	X	Qo	Qo	Qo
L	X or floating	X or floating	X or floating	X or floating	X or floating	L	L	L

**H** — HIGH voltage level

**L** — LOW voltage level

↓ — HIGH-to-LOW transition

↑ — LOW-to-HIGH transition

**X** — Don't care

## 6. Limiting values

**Table 4: Limiting values**

In accordance with the Absolute Maximum Rating System (IEC 60134).

Symbol	Parameter	Conditions	Min	Max	Unit
$V_{DD}$	supply voltage		-0.5	+2.5	V
$V_i$	receiver input voltage		[2], [3] -0.5	+2.5	V
$V_o$	driver output voltage		[2], [3] -0.5	$V_{DD} + 0.5$	V
$I_{IK}$	input clamp current	$V_i < 0\text{ V}$ or $V_i > V_{DD}$	-	$\pm 50$	mA
$I_{OK}$	output clamp current	$V_o < 0\text{ V}$ or $V_o > V_{DD}$	-	$\pm 50$	mA
$I_o$	continuous output current	$0 < V_o < V_{DD}$	-	$\pm 50$	mA
$I_{CCC}$	continuous current through each $V_{DD}$ or GND pin		-	$\pm 100$	mA
$T_{stg}$	storage temperature		-65	+150	°C

- [1] Stresses beyond those listed under 'absolute maximum ratings' may cause permanent damage to the device. These are stress ratings only and functional operation of the device at these or any other conditions beyond those indicated under 'recommended operating conditions' is not implied. Exposure to absolute-maximum-rated conditions for extended periods may affect device reliability.
- [2] The input and output negative-voltage ratings may be exceeded if the input and output current ratings are observed.
- [3] This value is limited to 2.5 V maximum.

## 7. Recommended operating conditions

**Table 5: Recommended operating conditions**

Symbol	Parameter	Conditions	Min	Nom	Max	Unit
$V_{DD}$	supply voltage		1.7	-	1.9	V
$V_{REF}$	reference voltage		$0.49 \times V_{DD}$	$0.50 \times V_{DD}$	$0.51 \times V_{DD}$	V
$V_{TT}$	termination voltage		$V_{REF} - 40\text{ mV}$	$V_{REF}$	$V_{REF} + 40\text{ mV}$	V
$V_i$	input voltage		0	-	$V_{DD}$	V
$V_{IH}$	AC HIGH-level input voltage	Data inputs, $\overline{CSR}$	$V_{REF} + 250\text{ mV}$	-	-	V
$V_{IL}$	AC LOW-level input voltage	Data inputs, $\overline{CSR}$	-	-	$V_{REF} - 250\text{ mV}$	V
$V_{IH}$	DC HIGH-level input voltage	Data inputs, $\overline{CSR}$	$V_{REF} + 125\text{ mV}$	-	-	V
$V_{IL}$	DC LOW-level input voltage	Data inputs, $\overline{CSR}$	-	-	$V_{REF} - 125\text{ mV}$	V
$V_{IH}$	HIGH-level input voltage	$\overline{RESET}$ , Cn	$0.65 \times V_{DD}$	-	$V_{DD}$	V
$V_{IL}$	LOW-level input voltage	$\overline{RESET}$ , Cn	-	-	$0.35 \times V_{DD}$	V
$V_{ICR}$	common mode input voltage range	CK, $\overline{CK}$	0.675	-	1.125	V
$V_{ID}$	differential input voltage	CK, $\overline{CK}$	600	-	-	mV
$I_{OH}$	HIGH-level output current		-	-	-8	mA
$I_{OL}$	LOW-level output current		-	-	8	mA
$T_{amb}$	operating ambient temperature in free air		0	-	+70	°C

- [1] The  $\overline{RESET}$  and Cn inputs of the device must be held at valid logic levels (not floating) to ensure proper device operation. The differential inputs must not be floating, unless  $\overline{RESET}$  is LOW.



## 8. Static characteristics

**Table 6: DC electrical characteristics**

Over recommended operating conditions, unless otherwise noted. Voltages are referenced to GND (ground = 0 V).

$T_{amb} = 0\text{ }^{\circ}\text{C}$  to  $+70\text{ }^{\circ}\text{C}$ .

Symbol	Parameter	Conditions	Min	Typ	Max	Unit
$V_{OH}$	HIGH-level output voltage	$I_{OH} = -6\text{ mA}$ ; $V_{DD} = 1.7\text{ V}$	1.2	-	-	V
$V_{OL}$	LOW-level output voltage	$I_{OL} = 6\text{ mA}$ ; $V_{DD} = 1.7\text{ V}$	-	-	0.5	V
$I_i$	input current	all inputs; $V_i = V_{DD}$ or GND; $V_{DD} = 1.9\text{ V}$	-5	-	+5	$\mu\text{A}$
$I_{DD}$	static standby current	$\overline{\text{RESET}} = \text{GND}$ ; $I_o = 0\text{ mA}$ ; $V_{DD} = 1.9\text{ V}$	-	-	100	$\mu\text{A}$
	static operating current	$\overline{\text{RESET}} = V_{DD}$ ; $I_o = 0\text{ mA}$ ; $V_{DD} = 1.9\text{ V}$ ; $V_i = V_{IH(AC)}$ or $V_{IL(AC)}$	-	-	40	mA
$I_{DDD}$	dynamic operating current, clock only	$\overline{\text{RESET}} = V_{DD}$ ; $V_i = V_{IH(AC)}$ or $V_{IL(AC)}$ ; CK and $\overline{\text{CK}}$ switching at 50% duty cycle. $I_o = 0\text{ mA}$ ; $V_{DD} = 1.9\text{ V}$	-	16	-	$\mu\text{A} / \text{MHz}$
	dynamic operating current, per each data input, 1:1 mode	$\overline{\text{RESET}} = V_{DD}$ ; $V_i = V_{IH(AC)}$ or $V_{IL(AC)}$ ; CK and $\overline{\text{CK}}$ switching at 50% duty cycle. One data input switching at half clock frequency, 50% duty cycle. $I_o = 0\text{ mA}$ ; $V_{DD} = 1.9\text{ V}$	-	11	-	$\mu\text{A} / \text{MHz}$
	dynamic operating current, per each data input, 1:2 mode	$\overline{\text{RESET}} = V_{DD}$ ; $V_i = V_{IH(AC)}$ or $V_{IL(AC)}$ ; CK and $\overline{\text{CK}}$ switching at 50% duty cycle. One data input switching at half clock frequency, 50% duty cycle. $I_o = 0\text{ mA}$ ; $V_{DD} = 1.9\text{ V}$	-	19	-	$\mu\text{A} / \text{MHz}$
$C_i$	input capacitance, data inputs, CSR	$V_i = V_{REF} \pm 250\text{ mV}$ ; $V_{DD} = 1.8\text{ V}$	2.5	-	3.5	pF
	input capacitance, CK and $\overline{\text{CK}}$	$V_{ICR} = 0.9\text{ V}$ ; $V_{ID} = 600\text{ mV}$ ; $V_{DD} = 1.8\text{ V}$	2	-	3	pF
	input capacitance, $\overline{\text{RESET}}$	$V_i = V_{DD}$ or GND; $V_{DD} = 1.8\text{ V}$	2	-	4	pF

## 9. Dynamic characteristics

**Table 7: Timing requirements**

Over recommended operating conditions;  $V_{DD} = 1.8 V \pm 0.1 V$ ;  $T_{amb} = 0^{\circ}C$  to  $+70^{\circ}C$ ; unless otherwise noted.

See Figures 5 through 10.

Symbol	Parameter	Conditions	Min	Typ	Max	Unit
$f_{CLOCK}$	clock frequency		-	-	450	MHz
$t_W$	pulse duration, CK, $\overline{CK}$ HIGH or LOW		1	-	-	ns
$t_{ACT}$	differential inputs active time		[1], [2]	-	10	ns
$t_{INACT}$	differential inputs inactive time		[1], [3]	-	15	ns
$t_{SU}$	set-up time	$\overline{DCS}$ before CK $\uparrow$ , $\overline{CK}$ $\downarrow$ , $\overline{CSR}$ HIGH	0.7	-	-	ns
		$\overline{DCS}$ before CK $\uparrow$ , $\overline{CK}$ $\downarrow$ , $\overline{CSR}$ LOW	0.5	-	-	ns
		$\overline{CSR}$ , ODT, CKE, and data before CK $\uparrow$ , $\overline{CK}$ $\downarrow$	0.5	-	-	ns
$t_H$	hold time	$\overline{DCS}$ , $\overline{CSR}$ , ODT, CKE, and data after CK $\uparrow$ , $\overline{CK}$ $\downarrow$	0.5	-	-	ns

[1] This parameter is not necessarily production tested.

[2] Data inputs must be active below a minimum time of  $t_{ACT}$  (max) after  $\overline{RESET}$  is taken HIGH.

[3] Data and clock inputs must be held at valid levels (not floating) a minimum time of  $t_{INACT}$  (max) after  $\overline{RESET}$  is taken LOW.

**Table 8: Switching characteristics**

Over recommended operating conditions;  $V_{DD} = 1.8 V \pm 0.1 V$ ;  $T_{amb} = 0^{\circ}C$  to  $+70^{\circ}C$ ;

Class I,  $V_{REF} = V_{TT} = V_{DD} \times 0.5$  and  $CL = 10$  pF (unless otherwise noted. See Figures 5 through 10.

Symbol	Parameter	Conditions	Min	Typ	Max	Unit	
$f_{MAX}$	maximum input clock frequency		450	-	-	MHz	
$t_{PDM}$	propagation delay	clock to output	[1]	1.41	-	1.8	ns
$t_{PDMSS}$	propagation delay, simultaneous switching	clock to output	[1], [2]	-	-	2.0	ns
$t_{PHL}$	propagation delay	reset to output	-	-	3	ns	

[1] Includes 350 ps of test-load transmission line delay.

[2] This parameter is not necessarily production tested.

**Table 9: Output edge rates**

Over recommended operating conditions, unless otherwise noted.  $V_{DD} = 1.8 V \pm 0.1 V$

Symbol	Parameter	Conditions	Min	Typ	Max	Unit
$dV/dt_r$	rising edge slew rate		1	-	4	V/ns
$dV/dt_f$	falling edge slew rate		1	-	4	V/ns
$dV/dt_{\Delta}$ [1]	absolute difference between $dV/dt_r$ and $dV/dt_f$		-	-	1	V/ns

[1] Difference between  $dV/dt_r$  (rising edge rate) and  $dV/dt_f$  (falling edge rate).

## 10. Test information

### 10.1 Test circuit

All input pulses are supplied by generators having the following characteristics: PRR  $\leq$  10 MHz;  $Z_o = 50 \Omega$ ; input slew rate = 1 V/ns  $\pm$  20%, unless otherwise specified.

The outputs are measured one at a time with one transition per measurement.

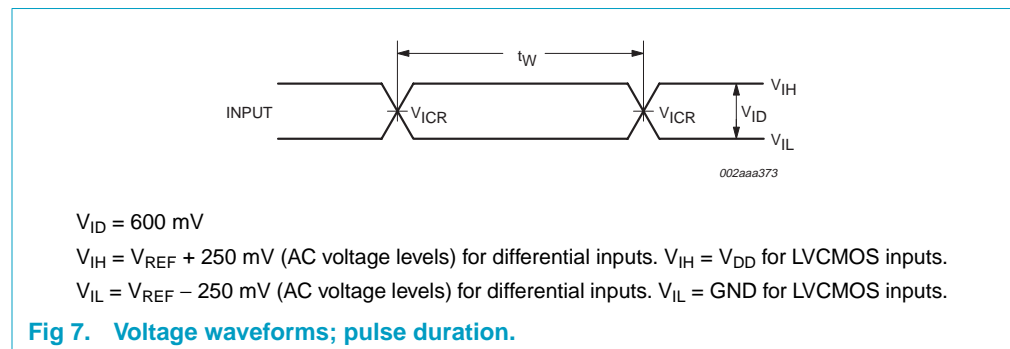
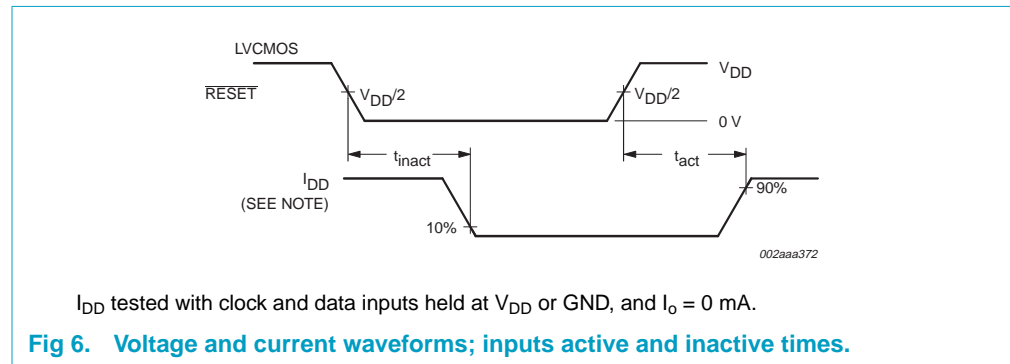
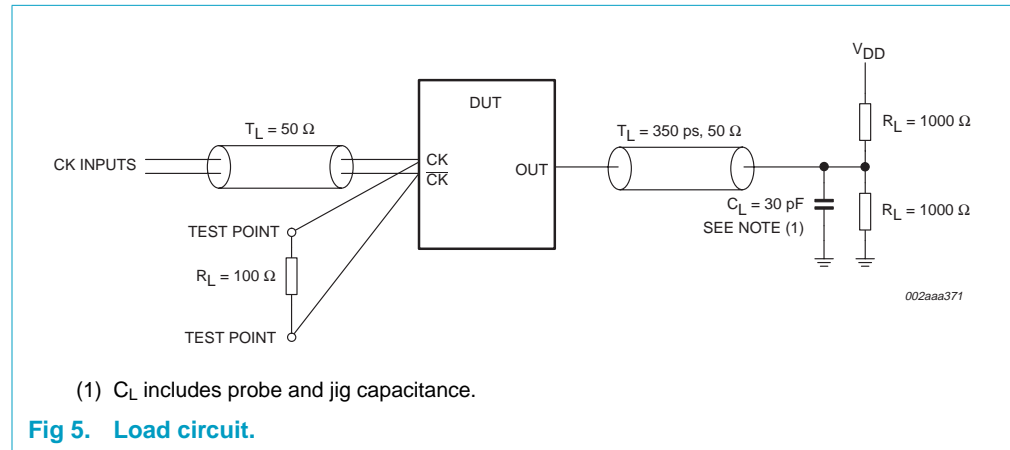

1.8 V configurable registered buffer for DDR2 RDIMM applications

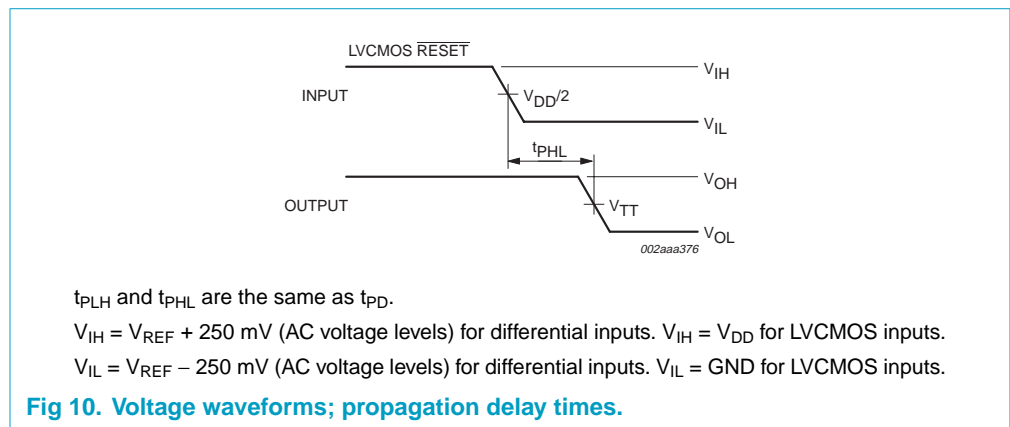
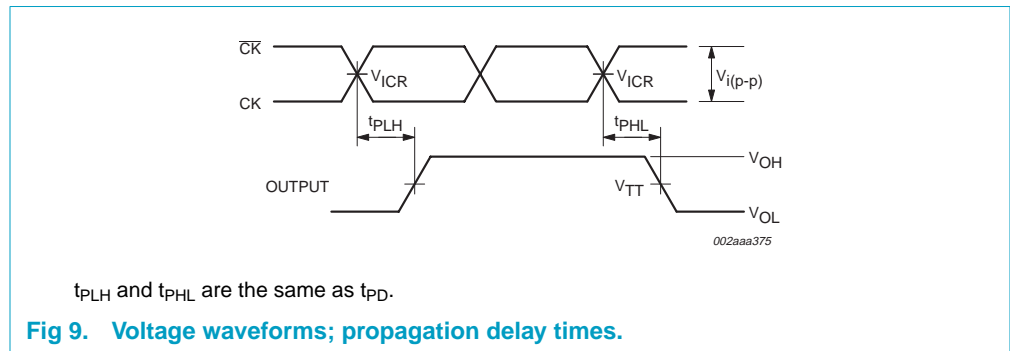
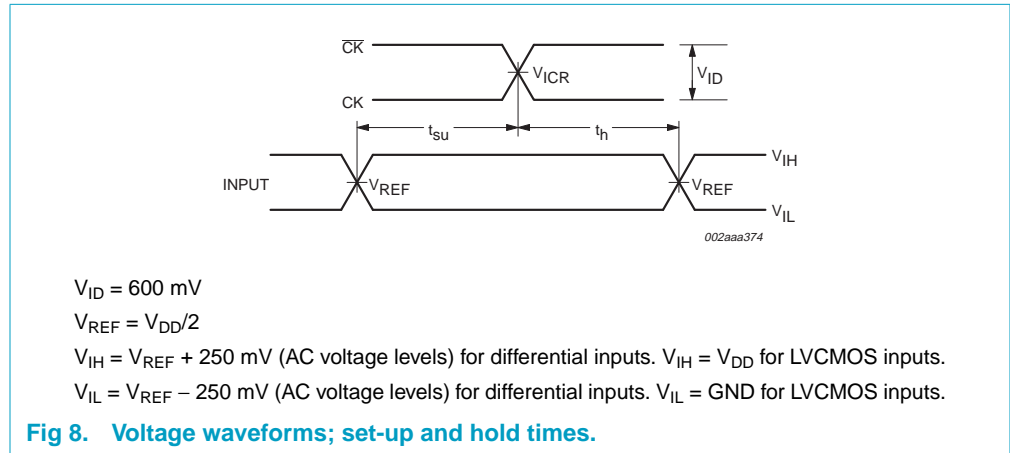

### 10.2 Output slew rate measurement

$V_{DD} = 1.8\text{ V} \pm 0.1\text{ V}$ .

All input pulses are supplied by generators having the following characteristics:  $PRR \leq 10\text{ MHz}$ ;  $Z_o = 50\ \Omega$ ; input slew rate =  $1\text{ V/ns} \pm 20\%$ , unless otherwise specified.

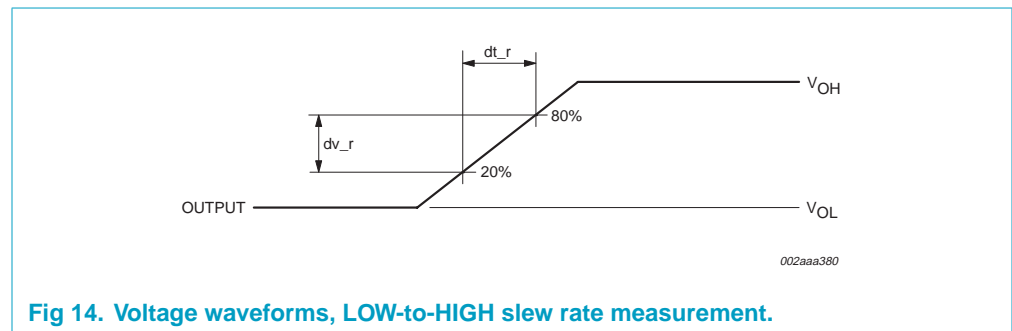
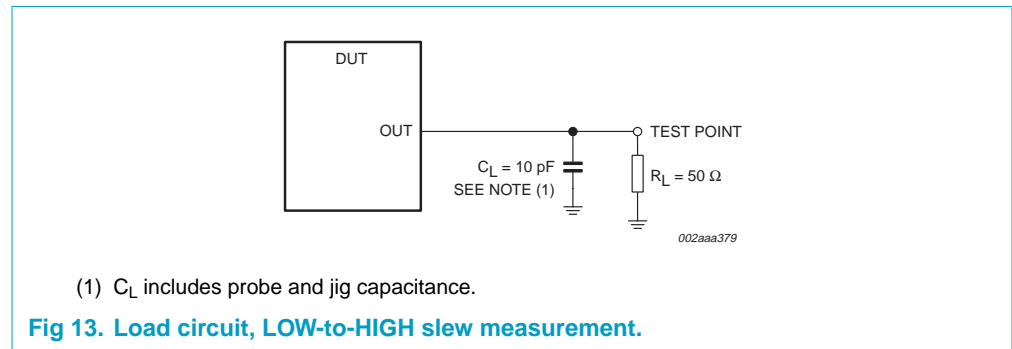
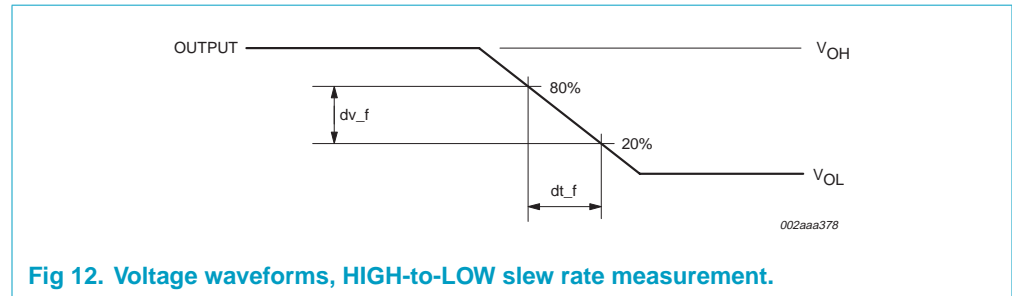
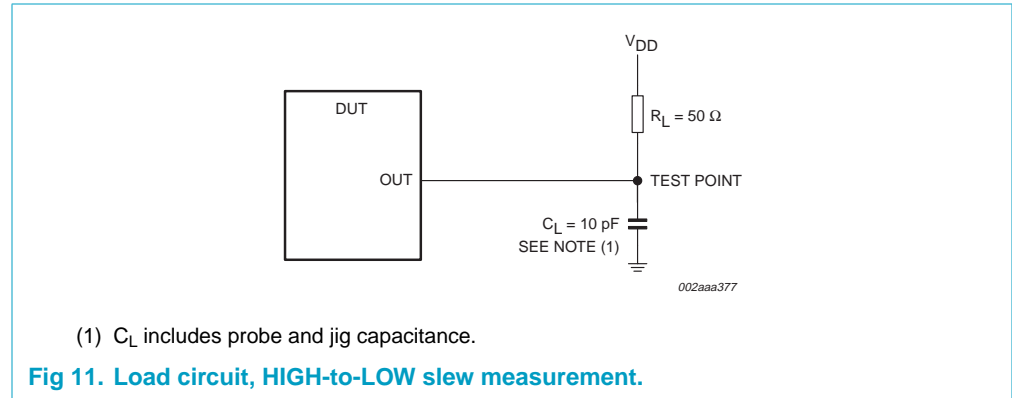

### 11. Package outline

LFBGA96: plastic low profile fine-pitch ball grid array package; 96 balls; body 13.5 x 5.5 x 1.05 mm SOT536-1

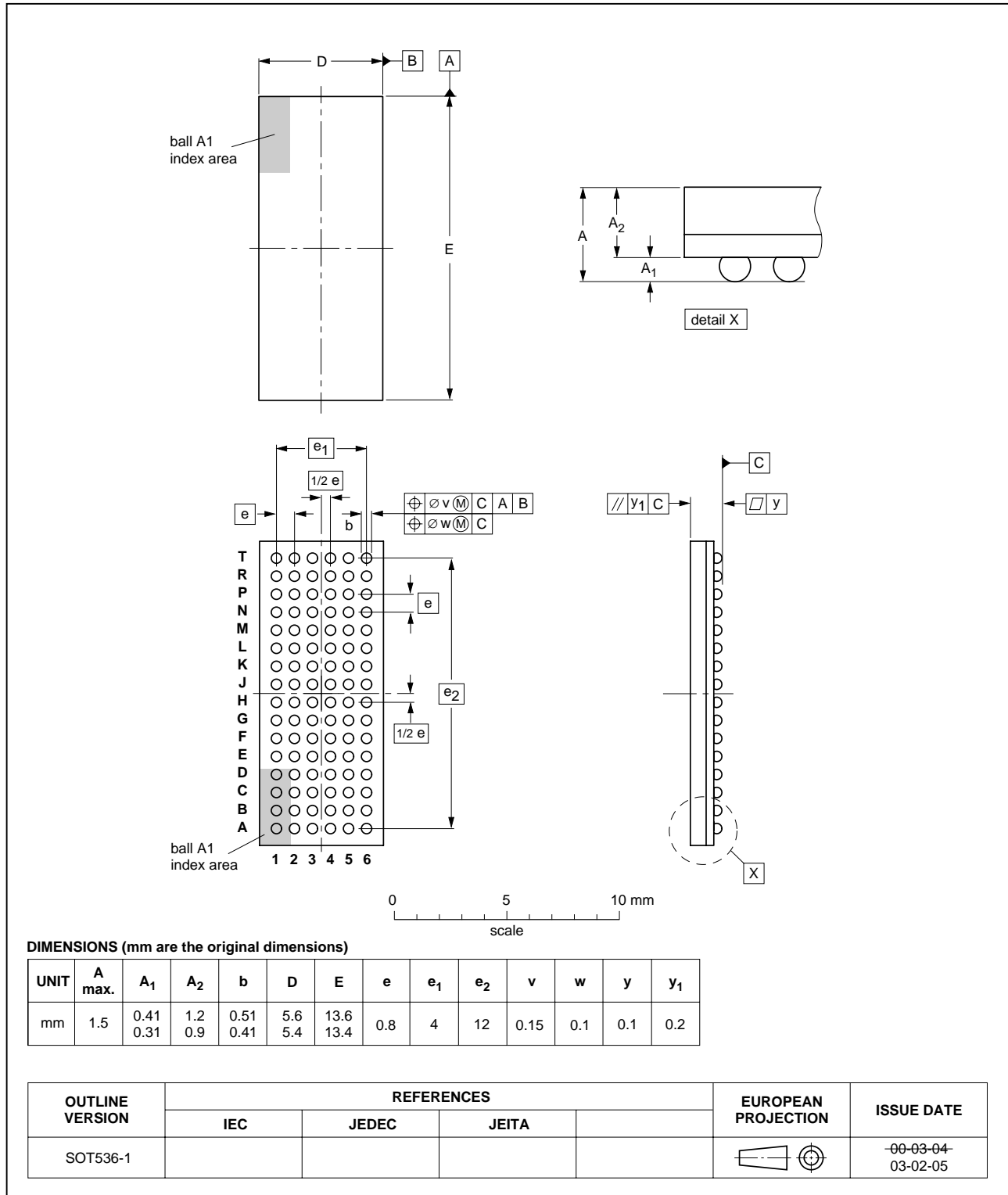

Fig 15. LFBGA96 package outline (SOT536-1).

## 12. Soldering

### 12.1 Introduction to soldering surface mount packages

This text gives a very brief insight to a complex technology. A more in-depth account of soldering ICs can be found in our *Data Handbook IC26; Integrated Circuit Packages* (document order number 9398 652 90011).

There is no soldering method that is ideal for all surface mount IC packages. Wave soldering can still be used for certain surface mount ICs, but it is not suitable for fine pitch SMDs. In these situations reflow soldering is recommended. In these situations reflow soldering is recommended.

### 12.2 Reflow soldering

Reflow soldering requires solder paste (a suspension of fine solder particles, flux and binding agent) to be applied to the printed-circuit board by screen printing, stencilling or pressure-syringe dispensing before package placement. Driven by legislation and environmental forces the worldwide use of lead-free solder pastes is increasing.

Several methods exist for reflowing; for example, convection or convection/infrared heating in a conveyor type oven. Throughput times (preheating, soldering and cooling) vary between 100 and 200 seconds depending on heating method.

Typical reflow peak temperatures range from 215 to 270 °C depending on solder paste material. The top-surface temperature of the packages should preferably be kept:

- below 225 °C (SnPb process) or below 245 °C (Pb-free process)
  - for all BGA, HTSSON..T and SSOP..T packages
  - for packages with a thickness  $\geq 2.5$  mm
  - for packages with a thickness  $< 2.5$  mm and a volume  $\geq 350$  mm<sup>3</sup> so called thick/large packages.
- below 240 °C (SnPb process) or below 260 °C (Pb-free process) for packages with a thickness  $< 2.5$  mm and a volume  $< 350$  mm<sup>3</sup> so called small/thin packages.

Moisture sensitivity precautions, as indicated on packing, must be respected at all times.

### 12.3 Wave soldering

Conventional single wave soldering is not recommended for surface mount devices (SMDs) or printed-circuit boards with a high component density, as solder bridging and non-wetting can present major problems.

To overcome these problems the double-wave soldering method was specifically developed.

If wave soldering is used the following conditions must be observed for optimal results:

- Use a double-wave soldering method comprising a turbulent wave with high upward pressure followed by a smooth laminar wave.

- For packages with leads on two sides and a pitch (e):
  - larger than or equal to 1.27 mm, the footprint longitudinal axis is **preferred** to be parallel to the transport direction of the printed-circuit board;
  - smaller than 1.27 mm, the footprint longitudinal axis **must** be parallel to the transport direction of the printed-circuit board.

The footprint must incorporate solder thieves at the downstream end.

- For packages with leads on four sides, the footprint must be placed at a 45° angle to the transport direction of the printed-circuit board. The footprint must incorporate solder thieves downstream and at the side corners.

During placement and before soldering, the package must be fixed with a droplet of adhesive. The adhesive can be applied by screen printing, pin transfer or syringe dispensing. The package can be soldered after the adhesive is cured.

Typical dwell time of the leads in the wave ranges from 3 to 4 seconds at 250 °C or 265 °C, depending on solder material applied, SnPb or Pb-free respectively.

A mildly-activated flux will eliminate the need for removal of corrosive residues in most applications.

## 12.4 Manual soldering

Fix the component by first soldering two diagonally-opposite end leads. Use a low voltage (24 V or less) soldering iron applied to the flat part of the lead. Contact time must be limited to 10 seconds at up to 300 °C.

When using a dedicated tool, all other leads can be soldered in one operation within 2 to 5 seconds between 270 and 320 °C.

## 12.5 Package related soldering information

**Table 10: Suitability of surface mount IC packages for wave and reflow soldering methods**

Package <sup>[1]</sup>	Soldering method	
	Wave	Reflow <sup>[2]</sup>
BGA, HTSSON..T <sup>[3]</sup> , LBGA, LFBGA, SQFP, SSOP..T <sup>[3]</sup> , TFBGA, USON, VFBGA	not suitable	suitable
DHVQFN, HBCC, HBGA, HLQFP, HSO, HSOP, HSQFP, HSSON, HTQFP, HTSSOP, HVQFN, HVSON, SMS	not suitable <sup>[4]</sup>	suitable
PLCC <sup>[5]</sup> , SO, SOJ	suitable	suitable
LQFP, QFP, TQFP	not recommended <sup>[5][6]</sup>	suitable
SSOP, TSSOP, VSO, VSSOP	not recommended <sup>[7]</sup>	suitable
CWQCCN..L <sup>[8]</sup> , PMFP <sup>[9]</sup> , WQCCN..L <sup>[8]</sup>	not suitable	not suitable

[1] For more detailed information on the BGA packages refer to the *(LF)BGA Application Note* (AN01026); order a copy from your Philips Semiconductors sales office.

[2] All surface mount (SMD) packages are moisture sensitive. Depending upon the moisture content, the maximum temperature (with respect to time) and body size of the package, there is a risk that internal or external package cracks may occur due to vaporization of the moisture in them (the so called popcorn effect). For details, refer to the Drypack information in the *Data Handbook IC26; Integrated Circuit Packages; Section: Packing Methods*.



- [3] These transparent plastic packages are extremely sensitive to reflow soldering conditions and must on no account be processed through more than one soldering cycle or subjected to infrared reflow soldering with peak temperature exceeding  $217\text{ °C} \pm 10\text{ °C}$  measured in the atmosphere of the reflow oven. The package body peak temperature must be kept as low as possible.
- [4] These packages are not suitable for wave soldering. On versions with the heatsink on the bottom side, the solder cannot penetrate between the printed-circuit board and the heatsink. On versions with the heatsink on the top side, the solder might be deposited on the heatsink surface.
- [5] If wave soldering is considered, then the package must be placed at a  $45^\circ$  angle to the solder wave direction. The package footprint must incorporate solder thieves downstream and at the side corners.
- [6] Wave soldering is suitable for LQFP, QFP and TQFP packages with a pitch (e) larger than 0.8 mm; it is definitely not suitable for packages with a pitch (e) equal to or smaller than 0.65 mm.
- [7] Wave soldering is suitable for SSOP, TSSOP, VSO and VSOP packages with a pitch (e) equal to or larger than 0.65 mm; it is definitely not suitable for packages with a pitch (e) equal to or smaller than 0.5 mm.
- [8] Image sensor packages in principle should not be soldered. They are mounted in sockets or delivered pre-mounted on flex foil. However, the image sensor package can be mounted by the client on a flex foil by using a hot bar soldering process. The appropriate soldering profile can be provided on request.
- [9] Hot bar soldering or manual soldering is suitable for PMFP packages.

## 13. Revision history

Table 11: Revision history

Rev	Date	CPCN	Description
01	20040712	-	Objective data (9397 750 13339)

## 14. Data sheet status

Level	Data sheet status <sup>[1]</sup>	Product status <sup>[2][3]</sup>	Definition
I	Objective data	Development	This data sheet contains data from the objective specification for product development. Philips Semiconductors reserves the right to change the specification in any manner without notice.
II	Preliminary data	Qualification	This data sheet contains data from the preliminary specification. Supplementary data will be published at a later date. Philips Semiconductors reserves the right to change the specification without notice, in order to improve the design and supply the best possible product.
III	Product data	Production	This data sheet contains data from the product specification. Philips Semiconductors reserves the right to make changes at any time in order to improve the design, manufacturing and supply. Relevant changes will be communicated via a Customer Product/Process Change Notification (CPCN).

[1] Please consult the most recently issued data sheet before initiating or completing a design.

[2] The product status of the device(s) described in this data sheet may have changed since this data sheet was published. The latest information is available on the Internet at URL <http://www.semiconductors.philips.com>.

[3] For data sheets describing multiple type numbers, the highest-level product status determines the data sheet status.

## 15. Definitions

**Short-form specification** — The data in a short-form specification is extracted from a full data sheet with the same type number and title. For detailed information see the relevant data sheet or data handbook.

**Limiting values definition** — Limiting values given are in accordance with the Absolute Maximum Rating System (IEC 60134). Stress above one or more of the limiting values may cause permanent damage to the device. These are stress ratings only and operation of the device at these or at any other conditions above those given in the Characteristics sections of the specification is not implied. Exposure to limiting values for extended periods may affect device reliability.

**Application information** — Applications that are described herein for any of these products are for illustrative purposes only. Philips Semiconductors make no representation or warranty that such applications will be suitable for the specified use without further testing or modification.

## 16. Disclaimers

**Life support** — These products are not designed for use in life support appliances, devices, or systems where malfunction of these products can reasonably be expected to result in personal injury. Philips Semiconductors customers using or selling these products for use in such applications do so at their own risk and agree to fully indemnify Philips Semiconductors for any damages resulting from such application.

**Right to make changes** — Philips Semiconductors reserves the right to make changes in the products - including circuits, standard cells, and/or software - described or contained herein in order to improve design and/or performance. When the product is in full production (status 'Production'), relevant changes will be communicated via a Customer Product/Process Change Notification (CPCN). Philips Semiconductors assumes no responsibility or liability for the use of any of these products, conveys no licence or title under any patent, copyright, or mask work right to these products, and makes no representations or warranties that these products are free from patent, copyright, or mask work right infringement, unless otherwise specified.

## Contact information

For additional information, please visit <http://www.semiconductors.philips.com>.

For sales office addresses, send e-mail to: [sales.addresses@www.semiconductors.philips.com](mailto:sales.addresses@www.semiconductors.philips.com).

Fax: +31 40 27 24825

## Contents

<b>1</b>	<b>Description</b> . . . . .	<b>1</b>
<b>2</b>	<b>Features</b> . . . . .	<b>2</b>
<b>3</b>	<b>Ordering information</b> . . . . .	<b>2</b>
<b>4</b>	<b>Pinning information</b> . . . . .	<b>3</b>
4.1	Pinning . . . . .	3
4.2	Pin description . . . . .	5
<b>5</b>	<b>Functional description</b> . . . . .	<b>6</b>
<b>6</b>	<b>Limiting values</b> . . . . .	<b>8</b>
<b>7</b>	<b>Recommended operating conditions</b> . . . . .	<b>8</b>
<b>8</b>	<b>Static characteristics</b> . . . . .	<b>9</b>
<b>9</b>	<b>Dynamic characteristics</b> . . . . .	<b>10</b>
<b>10</b>	<b>Test information</b> . . . . .	<b>11</b>
10.1	Test circuit . . . . .	11
10.2	Output slew rate measurement . . . . .	13
<b>11</b>	<b>Package outline</b> . . . . .	<b>14</b>
<b>12</b>	<b>Soldering</b> . . . . .	<b>15</b>
12.1	Introduction to soldering surface mount packages . . . . .	15
12.2	Reflow soldering . . . . .	15
12.3	Wave soldering . . . . .	15
12.4	Manual soldering . . . . .	16
12.5	Package related soldering information . . . . .	16
<b>13</b>	<b>Revision history</b> . . . . .	<b>17</b>
<b>14</b>	<b>Data sheet status</b> . . . . .	<b>18</b>
<b>15</b>	<b>Definitions</b> . . . . .	<b>18</b>
<b>16</b>	<b>Disclaimers</b> . . . . .	<b>18</b>

© Koninklijke Philips Electronics N.V. 2004.  
Printed in the U.S.A.

All rights are reserved. Reproduction in whole or in part is prohibited without the prior written consent of the copyright owner.

The information presented in this document does not form part of any quotation or contract, is believed to be accurate and reliable and may be changed without notice. No liability will be accepted by the publisher for any consequence of its use. Publication thereof does not convey nor imply any license under patent- or other industrial or intellectual property rights.

Date of release: 12 July 2004

Document order number: 9397 750 13339



# PHILIPS

*Let's make things better.*