

16A, 50V, 0.047 Ohm, N-Channel Power MOSFETs

The RFD16N05 and RFD16N05SM N-channel power MOSFETs are manufactured using the MegaFET process. This process, which uses feature sizes approaching those of LSI integrated circuits, gives optimum utilization of silicon, resulting in outstanding performance. They were designed for use in applications such as switching regulators, switching converters, motor drivers, and relay drivers. These transistors can be operated directly from integrated circuits.

Formerly developmental type TA09771.

Ordering Information

| PART NUMBER | PACKAGE | BRAND |
|-------------|----------|--------|
| RFD16N05 | TO-251AA | F16N05 |
| RFD16N05SM | TO-252AA | F16N05 |

NOTE: When ordering, use the entire part number. Add the suffix 9A to obtain the TO-252AA variant in the tape and reel, i.e., RFD16N05SM9A.

Features

- 16A, 50V
- $r_{DS(ON)} = 0.047\Omega$
- Temperature Compensating PSPICE® Model
- Peak Current vs Pulse Width Curve
- UIS Rating Curve
- 175°C Operating Temperature
- Related Literature
 - TB334 "Guidelines for Soldering Surface Mount Components to PC Boards"

Symbol

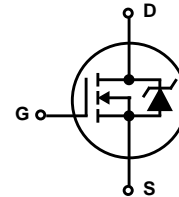

Packaging

JEDEC TO-251AA

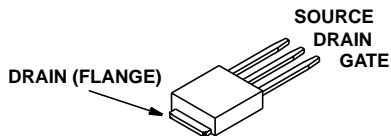

JEDEC TO-252AA

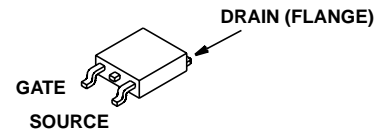

RFD16N05, RFD16N05SM

Absolute Maximum Ratings $T_C = 25^\circ\text{C}$, Unless Otherwise Specified

| | RFD16N05, RFD16N05SM, | UNITS |
|--|--------------------------------------|---------------------|
| Drain to Source Voltage (Note 1) | V_{DSS} 50 | V |
| Drain to Gate Voltage (Note 1) | V_{DGR} 50 | V |
| Continuous Drain Current | I_D 16 | A |
| Pulsed Drain Current (Note 3) | I_{DM} Refer to Peak Current Curve | |
| Gate to Source Voltage | V_{GS} ± 20 | V |
| Pulsed Avalanche Rating | E_{AS} Refer to Figure 5 | |
| Power Dissipation | P_D 72 | W |
| Derate above 25°C | 0.48 | W/ $^\circ\text{C}$ |
| Operating and Storage Temperature | T_J, T_{STG} -55 to 175 | $^\circ\text{C}$ |
| Maximum Temperature for Soldering | | |
| Leads at 0.063in (1.6mm) from Case for 10s | T_L 300 | $^\circ\text{C}$ |
| Package Body for 10s, See Techbrief 334 | T_{pkg} 260 | $^\circ\text{C}$ |

CAUTION: Stresses above those listed in "Absolute Maximum Ratings" may cause permanent damage to the device. This is a stress only rating and operation of the device at these or any other conditions above those indicated in the operational sections of this specification is not implied.

NOTE:

1. $T_J = 25^\circ\text{C}$ to 150°C .

Electrical Specifications $T_C = 25^\circ\text{C}$, Unless Otherwise Specified

| PARAMETER | SYMBOL | TEST CONDITIONS | MIN | TYP | MAX | UNITS |
|--|-----------------|---|-----|-----|-----------|--------------------|
| Drain to Source Breakdown Voltage | BV_{DSS} | $I_D = 250\mu\text{A}, V_{GS} = 0\text{V}$ (Figure 11) | 50 | - | - | V |
| Gate Threshold Voltage | $V_{GS(TH)}$ | $V_{GS} = V_{DS}, I_D = 250\mu\text{A}$ | 2 | - | 4 | V |
| Zero Gate Voltage Drain Current | I_{DSS} | $V_{DS} = \text{Rated } BV_{DSS}, V_{GS} = 0\text{V}$ | - | - | 1 | μA |
| | | $V_{DS} = 0.8 \times \text{Rated } BV_{DSS}, V_{GS} = 0\text{V}, T_C = 150^\circ\text{C}$ | - | - | 25 | μA |
| Gate to Source Leakage Current | I_{GSS} | $V_{GS} = \pm 20\text{V}$ | - | - | ± 100 | nA |
| Drain to Source On Resistance (Note 2) | $r_{DS(ON)}$ | $I_D = 16\text{A}, V_{GS} = 10\text{V}$ (Figure 9) | - | - | 0.047 | Ω |
| Turn-On Time | $t_{(ON)}$ | $V_{DD} = 25\text{V}, I_D = 8\text{A}, R_L = 3.125\Omega,$ $V_{GS} = 10\text{V}, R_{GS} = 25\Omega$ (Figure 13) | - | - | 65 | ns |
| Turn-On Delay Time | $t_{d(ON)}$ | | - | 14 | - | ns |
| Rise Time | t_r | | - | 30 | - | ns |
| Turn-Off Delay Time | $t_{d(OFF)}$ | | - | 55 | - | ns |
| Fall Time | t_f | | - | 30 | - | ns |
| Turn-Off Time | $t_{(OFF)}$ | | - | - | 125 | ns |
| Total Gate Charge | $Q_{g(TOT)}$ | $V_{GS} = 0\text{V to } 20\text{V}$ | - | - | 80 | nC |
| Gate Charge at 10V | $Q_{g(10)}$ | $V_{GS} = 0\text{V to } 10\text{V}$ | | | | |
| Threshold Gate Charge | $Q_{(TH)}$ | $V_{GS} = 0\text{V to } 2\text{V}$ | | | | |
| Input Capacitance | C_{ISS} | $V_{DS} = 25\text{V}, V_{GS} = 0\text{V}, f = 1\text{MHz}$ (Figure 12) | - | 900 | - | pF |
| Output Capacitance | C_{OSS} | | - | 325 | - | pF |
| Reverse Transfer Capacitance | C_{RSS} | | - | 100 | - | pF |
| Thermal Resistance Junction to Case | $R_{\theta JC}$ | | - | - | 2.083 | $^\circ\text{C/W}$ |
| Thermal Resistance Junction to Ambient | $R_{\theta JA}$ | TO-251 and TO-252 | - | - | 100 | $^\circ\text{C/W}$ |

Source to Drain Diode Specifications

| PARAMETER | SYMBOL | TEST CONDITIONS | MIN | TYP | MAX | UNITS |
|-------------------------------|----------|---|-----|-----|-----|-------|
| Source to Drain Diode Voltage | V_{SD} | $I_{SD} = 16\text{A}$ | - | - | 1.5 | V |
| Diode Reverse Recovery Time | t_{rr} | $I_{SD} = 16\text{A}, dI_{SD}/dt = 100\text{A}/\mu\text{s}$ | - | - | 125 | ns |

NOTES:

2. Pulse test: pulse width $\leq 250\mu\text{s}$, duty cycle $\leq 2\%$.
3. Repetitive rating: pulse width limited by maximum junction temperature. See Transient Thermal Impedance curve (Figure 3) and Peak Current Capability Curve (Figure 5).

Typical Performance Curves Unless Otherwise Specified

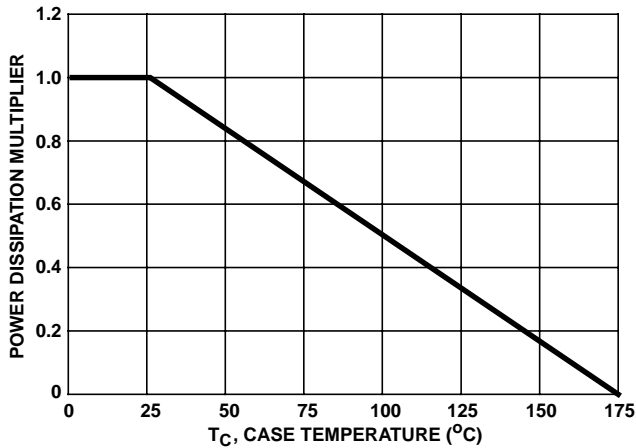

FIGURE 1. NORMALIZED POWER DISSIPATION vs CASE TEMPERATURE

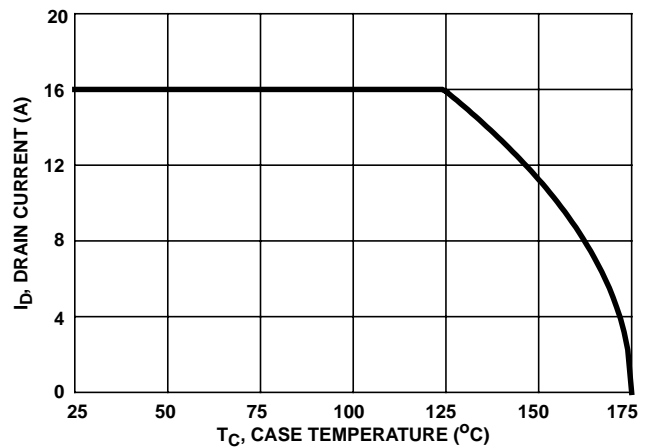

FIGURE 2. MAXIMUM CONTINUOUS DRAIN CURRENT vs CASE TEMPERATURE

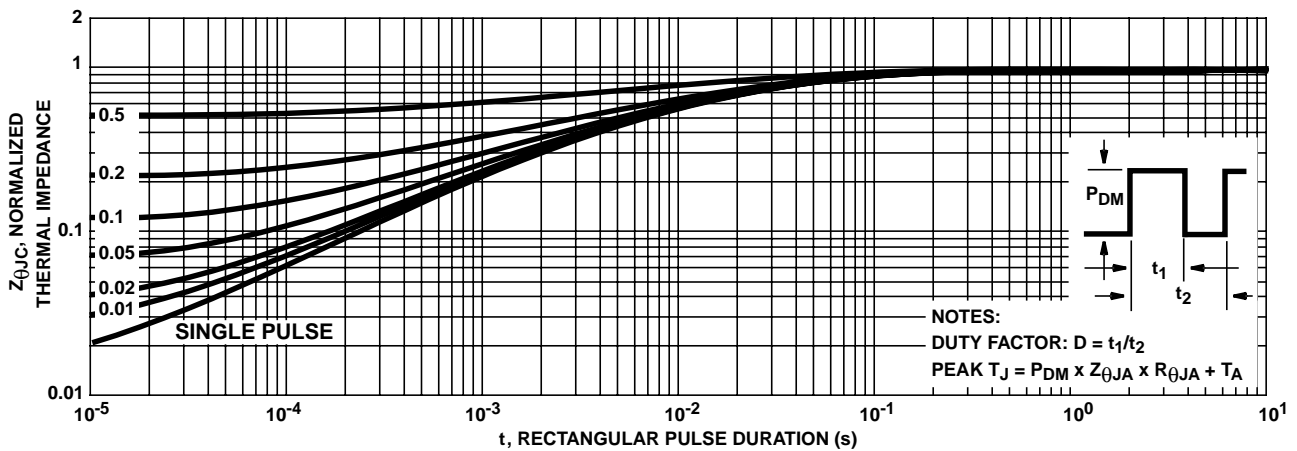

FIGURE 3. NORMALIZED MAXIMUM TRANSIENT THERMAL IMPEDANCE

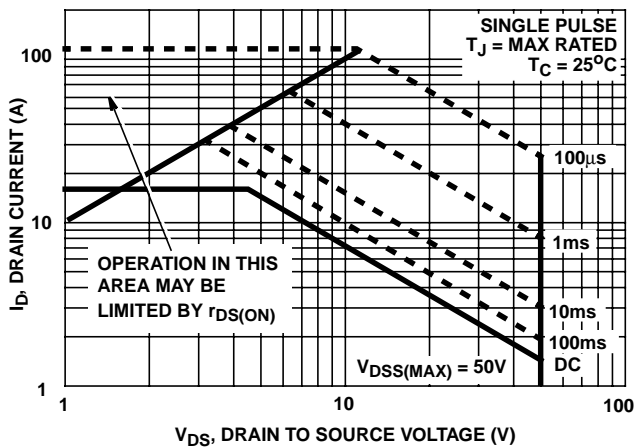

FIGURE 4. FORWARD BIAS SAFE OPERATING AREA

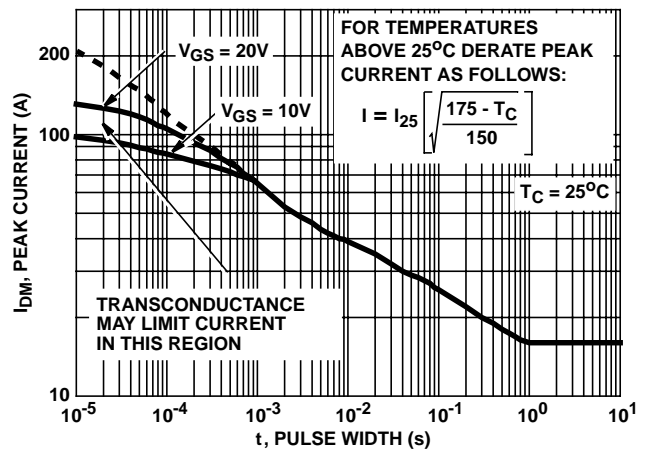
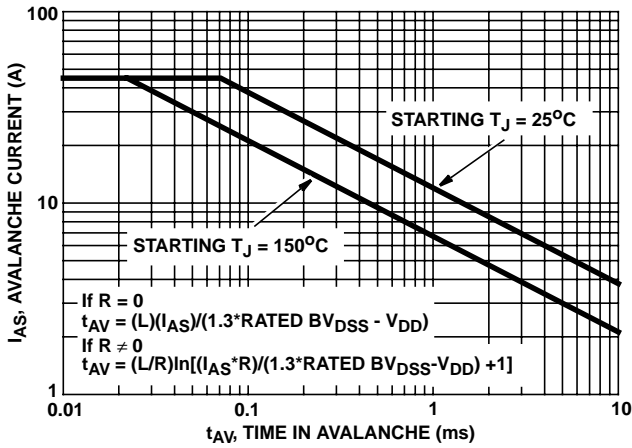

FIGURE 5. PEAK CURRENT CAPABILITY

Typical Performance Curves Unless Otherwise Specified (Continued)



NOTE: Refer to Intersil Application Notes AN9321 and AN9322.

FIGURE 6. UNCLAMPED INDUCTIVE SWITCHING

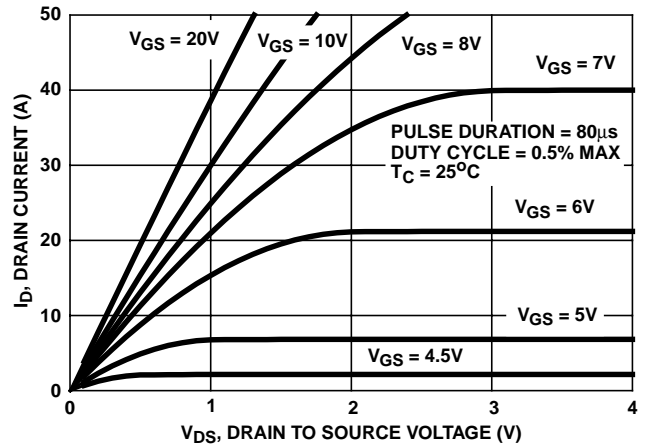

FIGURE 7. SATURATION CHARACTERISTICS

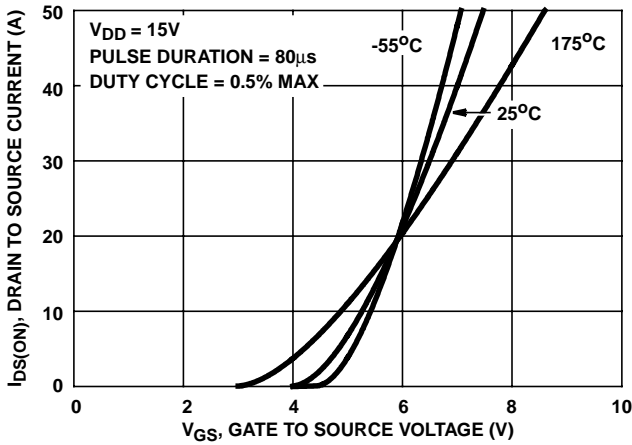

FIGURE 8. TRANSFER CHARACTERISTICS

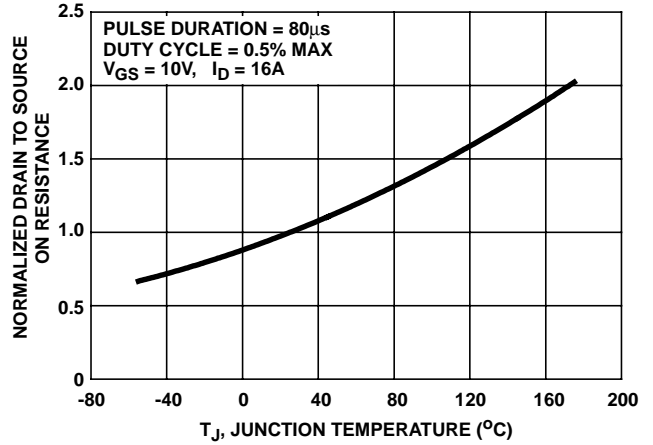

FIGURE 9. NORMALIZED DRAIN TO SOURCE ON RESISTANCE vs JUNCTION TEMPERATURE

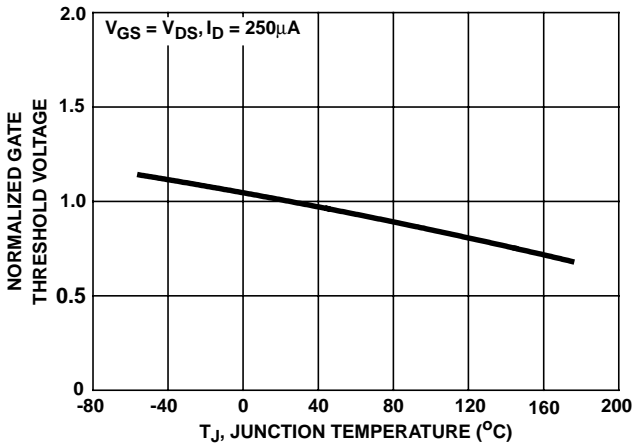

FIGURE 10. NORMALIZED GATE THRESHOLD VOLTAGE vs JUNCTION TEMPERATURE

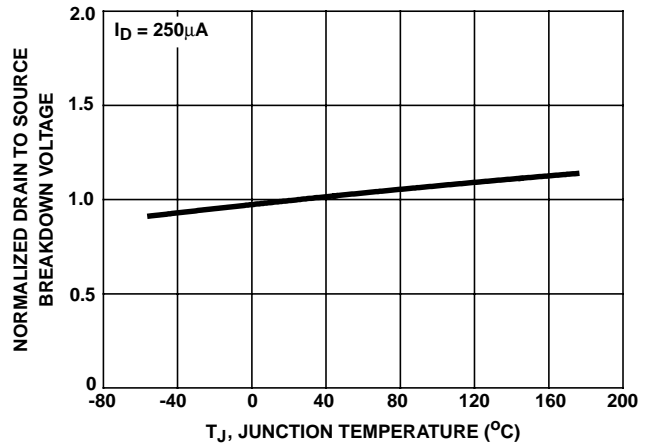

FIGURE 11. NORMALIZED DRAIN TO SOURCE BREAKDOWN VOLTAGE vs JUNCTION TEMPERATURE

Typical Performance Curves Unless Otherwise Specified (Continued)

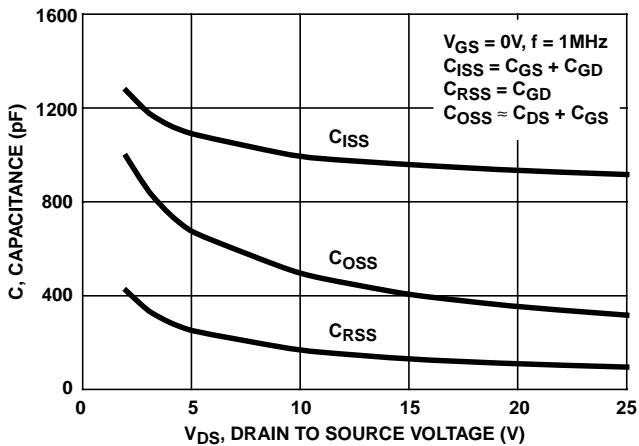
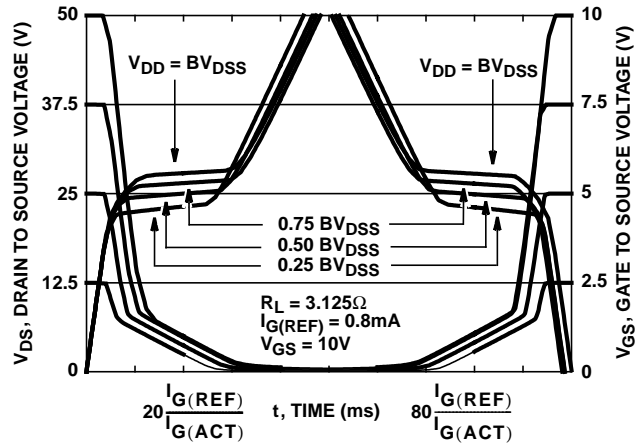

FIGURE 12. CAPACITANCE vs DRAIN TO SOURCE VOLTAGE



NOTE: Refer to Intersil Application Notes AN7254 and AN7260.

FIGURE 13. NORMALIZED SWITCHING WAVEFORMS FOR CONSTANT GATE CURRENT

Test Circuits and Waveforms

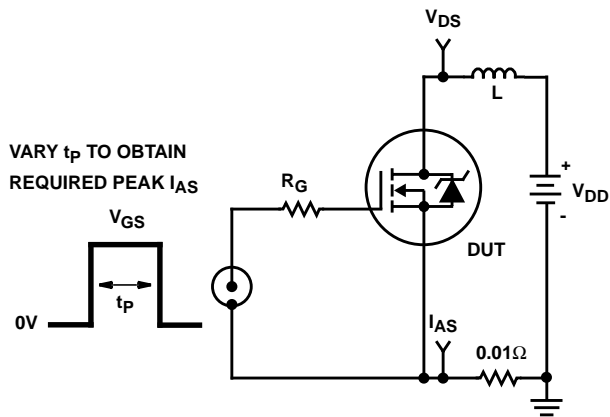

FIGURE 14. UNCLAMPED ENERGY TEST CIRCUIT

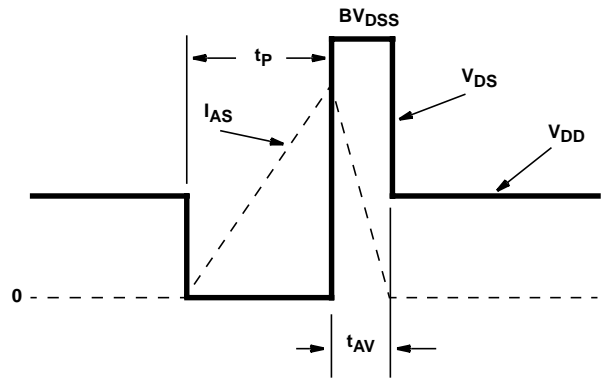

FIGURE 15. UNCLAMPED ENERGY WAVEFORMS

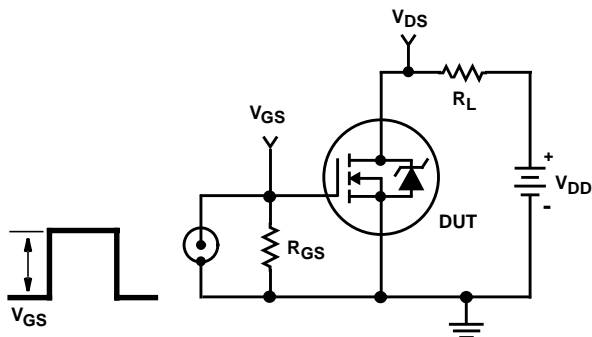

FIGURE 16. SWITCHING TIME TEST CIRCUIT

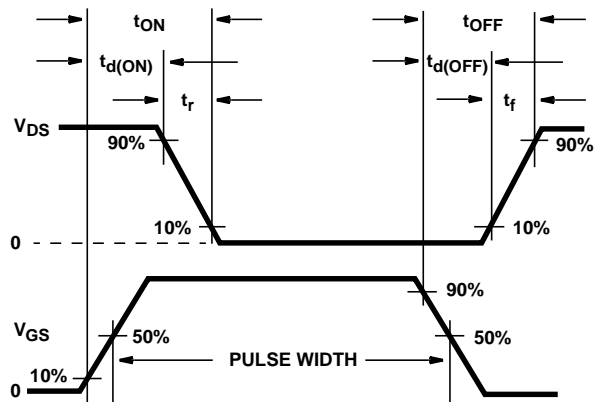

FIGURE 17. RESISTIVE SWITCHING WAVEFORMS

Test Circuits and Waveforms (Continued)

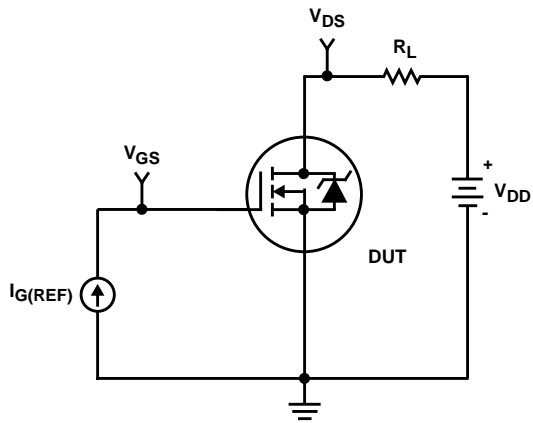

FIGURE 18. GATE CHARGE TEST CIRCUIT

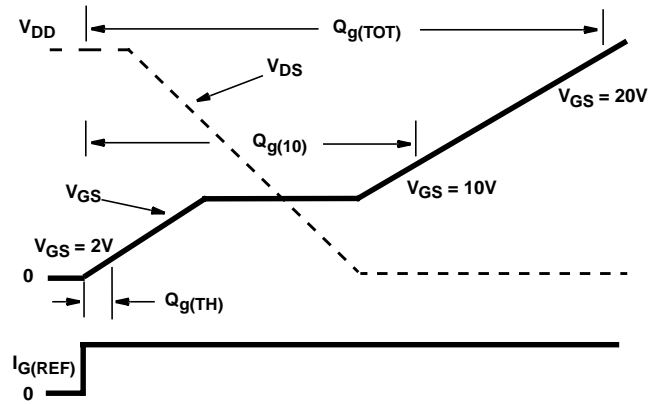

FIGURE 19. GATE CHARGE WAVEFORM

PSPICE Electrical Model

.SUBCKT RFD16N05 2 1 3; rev 10/31/94

CA 12 8 1.788e-10
 CB 15 14 1.875e-10
 CIN 6 8 8.33e-10

DBODY 7 5 DBDMOD
 DBREAK 5 11 DBKMOD
 DPLCAP 10 5 DPLCAPMOD

EBREAK 11 7 17 18 64.89
 EDS 14 8 5 8 1
 EGS 13 8 6 8 1
 ESG 6 10 6 8 1
 EVTO 20 6 18 8 1

IT 8 17 1

LDRAIN 2 5 1e-9
 LGATE 1 9 4.56e-9
 LSOURCE 3 7 4.13e-9

MOS1 16 6 8 8 MOSMOD M = 0.99
 MOS2 16 21 8 8 MOSMOD M = 0.01

RBREAK 17 18 RBKMOD 1
 RDRAIN 50 16 RDSMOD 0.4e-3
 RGATE 9 20 3.0
 RIN 6 8 1e9
 RSCL1 5 51 RSCLMOD 1e-6
 RSCL2 5 50 1e3
 RSOURCE 8 7 RDSMOD 21.5e-3
 RVTO 18 19 RVTOMOD 1

S1A 6 12 13 8 S1AMOD
 S1B 13 12 13 8 S1BMOD
 S2A 6 15 14 13 S2AMOD
 S2B 13 15 14 13 S2BMOD

VBAT 8 19 DC 1
 VTO 21 6 0.82

ESCL 51 50 VALUE = {(V(5,51)/ABS(V(5,51)))*(PWR(V(5,51)*1e6/94,7))}

.MODEL DBDMOD D (IS = 2.5e-13 RS = 7.1e-3 TRS1 = 3.04e-3 TRS2 = -10e-6 CJO = 1.12e-9 TT = 5.6e-8)
 .MODEL DBKMOD D (RS = 2.51e-1 TRS1 = -6.57e-4 TRS2 = 1.66e-6)
 .MODEL DPLCAPMOD D (CJO = 6.1e-10 IS = 1e-30 N = 10)
 .MODEL MOSMOD NMOS (VTO = 3.96 KP = 16.68 IS = 1e-30 N = 10 TOX = 1 L = 1u W = 1u)
 .MODEL RBKMOD RES (TC1 = 1.07e-3 TC2 = -7.19e-7)
 .MODEL RDSMOD RES (TC1 = 5.45e-3 TC2 = 1.66e-5)
 .MODEL RSCLMOD RES (TC1 = 1.25e-3 TC2 = 17e-6)
 .MODEL RVTOMOD RES (TC1 = -5.15e-3 TC2 = -4.83e-6)
 .MODEL S1AMOD VSWITCH (RON = 1e-5 ROFF = 0.1 VON = -5.25 VOFF = -3.25)
 .MODEL S1BMOD VSWITCH (RON = 1e-5 ROFF = 0.1 VON = -3.25 VOFF = -5.25)
 .MODEL S2AMOD VSWITCH (RON = 1e-5 ROFF = 0.1 VON = 0.56 VOFF = 5.56)
 .MODEL S2BMOD VSWITCH (RON = 1e-5 ROFF = 0.1 VON = 5.56 VOFF = 0.56)

.ENDS

NOTE: For further discussion of the PSPICE model, consult **A New PSPICE Sub-Circuit for the Power MOSFET Featuring Global Temperature Options**; written by William J. Hepp and C. Frank Wheatley.

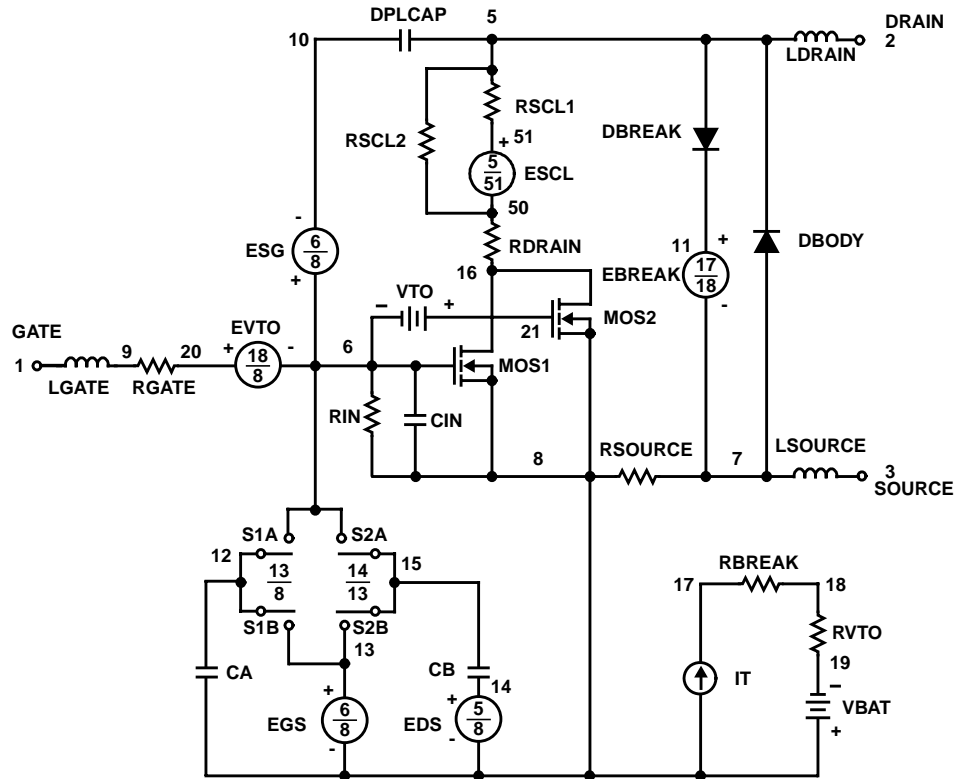

All Intersil semiconductor products are manufactured, assembled and tested under **ISO9000** quality systems certification.

Intersil semiconductor products are sold by description only. Intersil Corporation reserves the right to make changes in circuit design and/or specifications at any time without notice. Accordingly, the reader is cautioned to verify that data sheets are current before placing orders. Information furnished by Intersil is believed to be accurate and reliable. However, no responsibility is assumed by Intersil or its subsidiaries for its use; nor for any infringements of patents or other rights of third parties which may result from its use. No license is granted by implication or otherwise under any patent or patent rights of Intersil or its subsidiaries.

For information regarding Intersil Corporation and its products, see web site <http://www.intersil.com>

Sales Office Headquarters

NORTH AMERICA

Intersil Corporation
P. O. Box 883, Mail Stop 53-204
Melbourne, FL 32902
TEL: (407) 724-7000
FAX: (407) 724-7240

EUROPE

Intersil SA
Mercure Center
100, Rue de la Fusee
1130 Brussels, Belgium
TEL: (32) 2.724.2111
FAX: (32) 2.724.22.05

ASIA

Intersil (Taiwan) Ltd.
7F-6, No. 101 Fu Hsing North Road
Taipei, Taiwan
Republic of China
TEL: (886) 2 2716 9310
FAX: (886) 2 2715 3029