

SELF-OSCILLATING FULL-BRIDGE DRIVER IC

Features

- Integrated 600V Full-Bridge Gate Driver
- CT, RT programmable oscillator
- 15.6V Zener Clamp on VCC
- Micropower Startup
- Logic Level Latched Shutdown Pin
- Non-latched shutdown on CT pin (1/6th VCC)
- Internal bootstrap FETs
- Excellent Latch Immunity on All Inputs & Outputs
- ESD Protection on All Pins
- 14-lead SOIC or PDIP package
- 1.0 usec (typ.) internal deadline

Description

The IRS2453D is based on the popular IR2153 self-oscillating half-bridge gate driver IC, and incorporates a high voltage full-bridge gate driver with a front end oscillator similar to the industry standard CMOS 555 timer. HVIC and latch immune CMOS technologies enable ruggedized monolithic construction. The output driver features a high pulse current buffer stage designed for minimum driver cross-conduction. Noise immunity is achieved with low di/dt peak of the gate drivers, and with a undervoltage lockout hysteresis greater than 1.5V. The IRS2453D also includes latched and non-latched shutdown pins.

Package

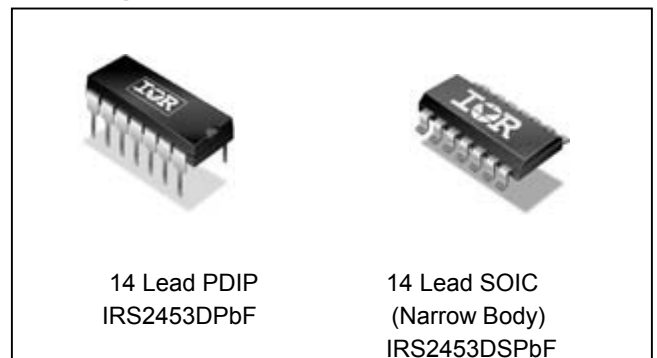

Typical Connection Diagram

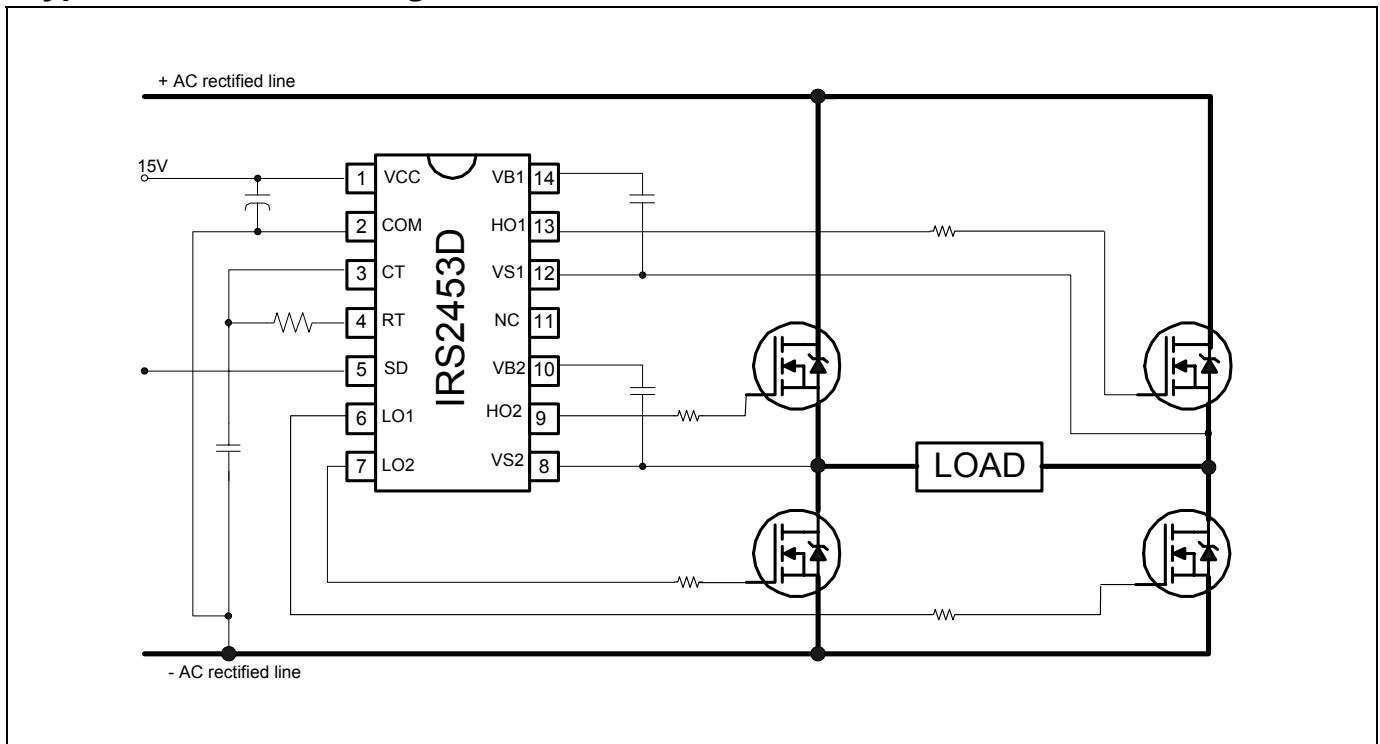

* Please note that this datasheet contains advanced information which could change before the product is released to production.

Absolute Maximum Ratings

Absolute maximum ratings indicate sustained limits beyond which damage to the device may occur. All voltage parameters are absolute voltages referenced to COM, all currents are defined positive into any lead. The thermal resistance and power dissipation ratings are measured under board mounted and still air conditions.

Parameter		Min.	Max.	Units
Symbol	Definition			
V_{B1}, V_{B2}	High Side Floating Supply Voltage	-0.3	625	V
V_{S1}, V_{S2}	High Side Floating Supply Offset Voltage	$V_B - 25$	$V_B + 0.3$	V
V_{HO1}, V_{HO2}	High-Side Floating Output Voltage	$V_S - 0.3$	$V_B + 0.3$	V
V_{LO1}, V_{LO2}	Low-Side Output Voltage	-0.3	$V_{CC} + 0.3$	V
V_{RT}	R_T Pin Voltage	-0.3	$V_{CC} + 0.3$	V
V_{CT}	C_T Pin Voltage	-0.3	$V_{CC} + 0.3$	V
V_{SD}	SD Pin Voltage	-0.3	$V_{CC} + 0.3$	V
I_{RT}	R_T Pin Current	-5	5	mA
I_{CC}	Supply Current (Note 1)	---	25	mA
dV_S/dt	Allowable Offset Voltage Slew Rate	-50	50	V/ns
P_D	Maximum Power Dissipation @ $T_A \leq +25^\circ\text{C}$, 8-Pin DIP	---	1.0	W
P_D	Maximum Power Dissipation @ $T_A \leq +25^\circ\text{C}$, 8-Pin SOIC	---	0.625	W
$R_{\theta JA}$	Thermal Resistance, Junction to Ambient, 8-Pin DIP	---	125	$^\circ\text{C}/\text{W}$
$R_{\theta JA}$	Thermal Resistance, Junction to Ambient, 8-Pin SOIC	---	200	$^\circ\text{C}/\text{W}$
T_J	Junction Temperature	-55	150	$^\circ\text{C}$
T_S	Storage Temperature	-55	150	
T_L	Lead Temperature (Soldering, 10 seconds)	---	300	

Note 1: This IC contains a zener clamp structure between the chip V_{CC} and COM which has a nominal breakdown voltage of 15.6V. Please note that this supply pin should not be driven by a DC, low impedance power source greater than the V_{CLAMP} specified in the Electrical Characteristics section.

Recommended Operating Conditions

For proper operation the device should be used within the recommended conditions.

Parameter		Min.	Max.	Units
Symbol	Definition			
V_{BS1}, V_{BS2}	High Side Floating Supply Voltage	$V_{CC} - 0.7$	V_{CLAMP}	V
V_{S1}, V_{S2}	Steady State High Side Floating Supply Offset Voltage	-3.0 (Note 2)	600	V
V_{CC}	Supply Voltage	V_{CCUV+}	V_{CLAMP}	V
I_{CC}	Supply Current	(Note 3)	5	mA
T_J	Junction Temperature	-25	125	°C

Note 2: Care should be taken to avoid output switching conditions where the V_S node flies inductively below ground by more than 5V.

Note 3: Enough current should be supplied to the V_{CC} pin of the IC to keep the internal 15.6V zener diode clamping the voltage at this pin.

Recommended Component Values

Parameter		Min.	Max.	Units
Symbol	Component			
R_T	Timing Resistor Value	1	---	k Ω
C_T	C_T Pin Capacitor Value	330	---	pF

$V_{BIAS} (V_{CC}, V_{BS}) = 14V, V_S = 0V$ and $T_A = 25^\circ C, C_{LO1} = C_{LO2} = C_{HO1} = C_{HO2} = 1nF.$

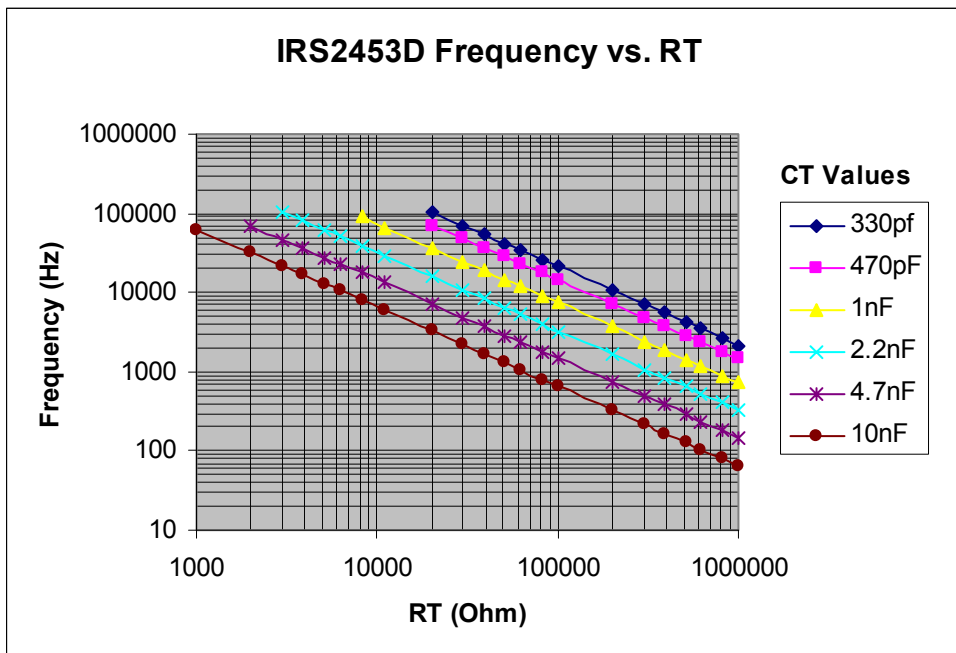

Electrical Characteristics

VBIAS (VCC, VBS) = 14V, CT = 1 nF and TA = 25°C unless otherwise specified. The VO and IO parameters are referenced to COM and are applicable to the respective output leads: HO or LO. CLO1=CLO2=CHO1=CHO2=1nF.

Symbol	Definition	Min	Typ	Max	Units	Test Conditions
Low Voltage Supply Characteristics						
V _{CCUV+}	Rising V _{CC} Undervoltage Lockout Threshold	10.0	11.0	12.0	V	
V _{CCUV-}	Falling V _{CC} Undervoltage Lockout Threshold	8.0	9.0	10.0		
V _{CCUVHYS}	V _{CC} Undervoltage Lockout Hysteresis	1.6	2.0	2.4		
I _{QCCUV}	Micropower Startup V _{CC} Supply Current	---	140	200	μA	V _{CC} ≤ V _{CCUV-}
I _{QCC}	Quiescent V _{CC} Supply Current	---	1.3	2.0	mA	
V _{CLAMP}	V _{CC} Zener Clamp Voltage	14.6	15.6	16.6	V	I _{CC} = 5mA
Floating Supply Characteristics						
I _{QBS1UV} , I _{QBS2UV}	Micropower Startup V _{BS} Supply Current	---	3	10	μA	V _{CC} ≤ V _{CCUV-} , V _{CC} = V _{BS}
I _{QBS1} , I _{QBS2}	Quiescent V _{BS} Supply Current	---	60	100	μA	
V _{BS1UV+} , V _{BS2UV+}	V _{BS} Supply Undervoltage Positive Going Threshold	8.0	9.0	10.0	V	
V _{BS1UV-} , V _{BS2UV-}	V _{BS} Supply Undervoltage negative Going Threshold	7.0	8.0	9.0		
I _{LK1} , I _{LK2}	Offset Supply Leakage Current	---	---	50	μA	V _B = V _S = 600V
Oscillator I/O Characteristics						
f _{OSC}	Oscillator Frequency	19.6	20.2	20.8	kHz	R _T = 36.5kΩ
		89	95	101		R _T = 7.15kΩ
d	R _T Pin Duty Cycle	48	50	52	%	f _o < 100kHz
I _{CT}	C _T Pin Current	---	0.05	1.0	μA	
I _{CTUV}	UV-Mode C _T Pin Pulldown Current	1	5	---	mA	V _{CC} = 7V
V _{CT+}	Upper C _T Ramp Voltage Threshold	---	9.1	---	V	
V _{CT-}	Lower C _T Ramp Voltage Threshold	---	4.8	---		
V _{RT+}	High-Level R _T Output Voltage, V _{CC} - V _{RT}	---	10	50	mV	I _{RT} = 100μA
		---	100	300	mV	I _{RT} = 1mA
V _{RT-}	Low-Level R _T Output Voltage	---	10	50	mV	I _{RT} = 100μA
		---	100	300	mV	I _{RT} = 1mA
V _{RTUV}	UV-Mode R _T Output Voltage	---	0	100	mV	V _{CC} ≤ V _{CCUV-}

Electrical Characteristics

VBIAS (VCC, VBS) = 14V, CT = 1 nF and TA = 25°C unless otherwise specified. The VO and IO parameters are referenced to COM and are applicable to the respective output leads: HO or LO. CLO1=CLO2=CHO1=CHO2=1nF.

Symbol	Definition	Min	Typ	Max	Units	Test Conditions
Gate Driver Output Characteristics						
VOH	High-Level Output Voltage, VBIAS - VO	---	VCC	---		IO = 0A
VOL	Low-Level Output Voltage, VO	---	COM	---		IO = 0A
VOL_UV	UV-Mode Output Voltage, VO	---	COM	---		IO = 0A, VCC ≤ VCCUV-
tr	Output Rise Time	---	120	220	nsec	
tf	Output Fall Time	---	50	100		
tSD	Shutdown Propagation Delay	---	275	---		
tD	Output Deadtime (HO or LO)	0.75	1.0	1.50	μsec	
IO+	Output source current	---	180	---	mA	
IO-	Output sink current	---	260	---		
Shutdown						
VSD	Shutdown Threshold at SD pin (latched)	---	2.0	---	V	
VCTSD	CT Voltage Shutdown Threshold (non latched)	---	2.3	---	V	
VRTSD	SD-Mode RT Output Voltage, VCC - VRT	---	10	50	mV	IRT = 100μA, VCT = 0V
		---	100	300	mV	IRT = 1mA, VCT = 0V
Bootstrap FET Characteristics						
VB1_ON VB2_ON	VB when the bootstrap FET is on	---	13.7	---	V	
IB1_CAP IB2_CAP	VB source current when FET is on	30	55	---	mA	CBS=0.1uF
IB1_10V IB2_10V	VB source current when FET is on	8	12	---		VB=10V

Functional Block Diagram

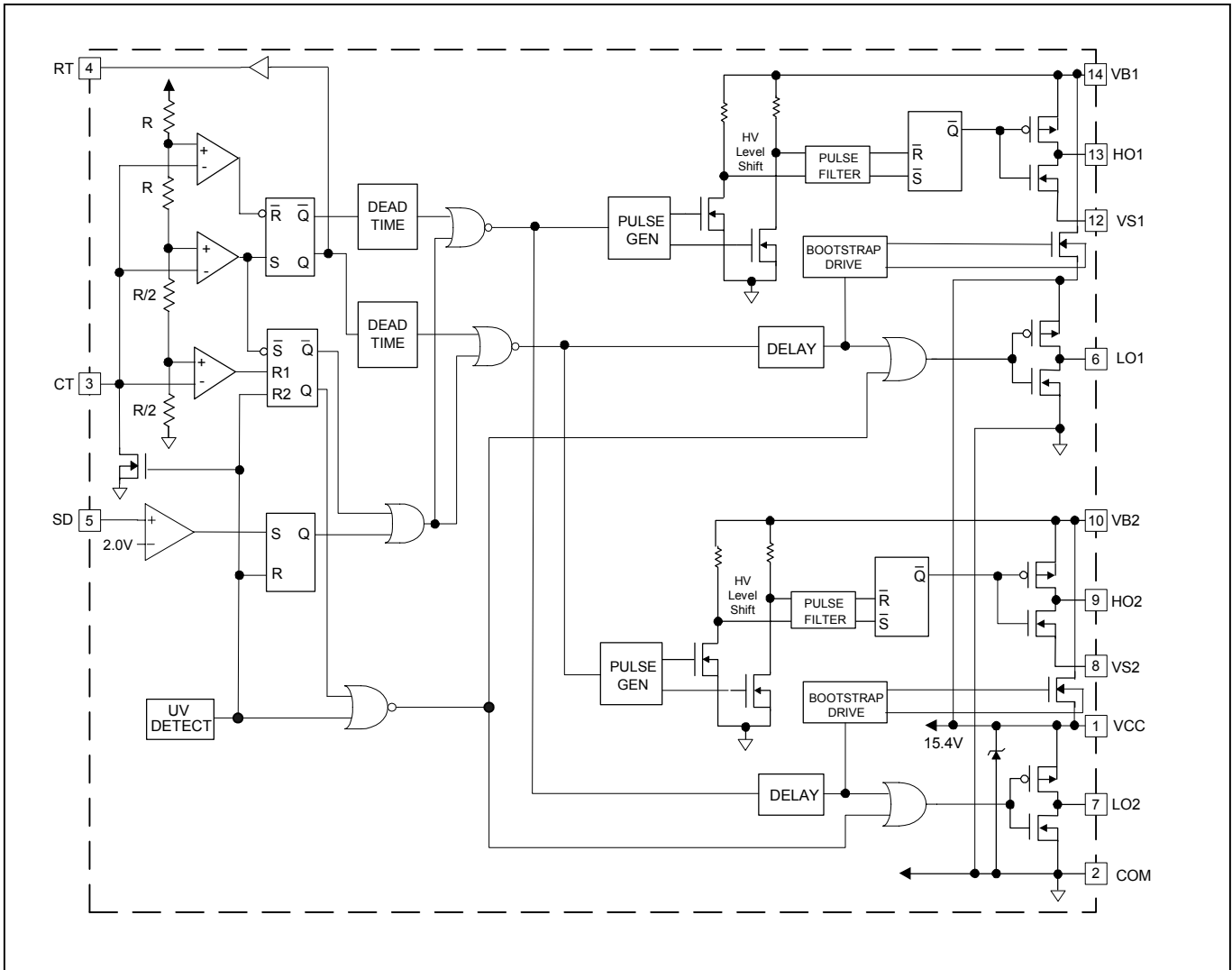

All values are typical.

Timing Diagram

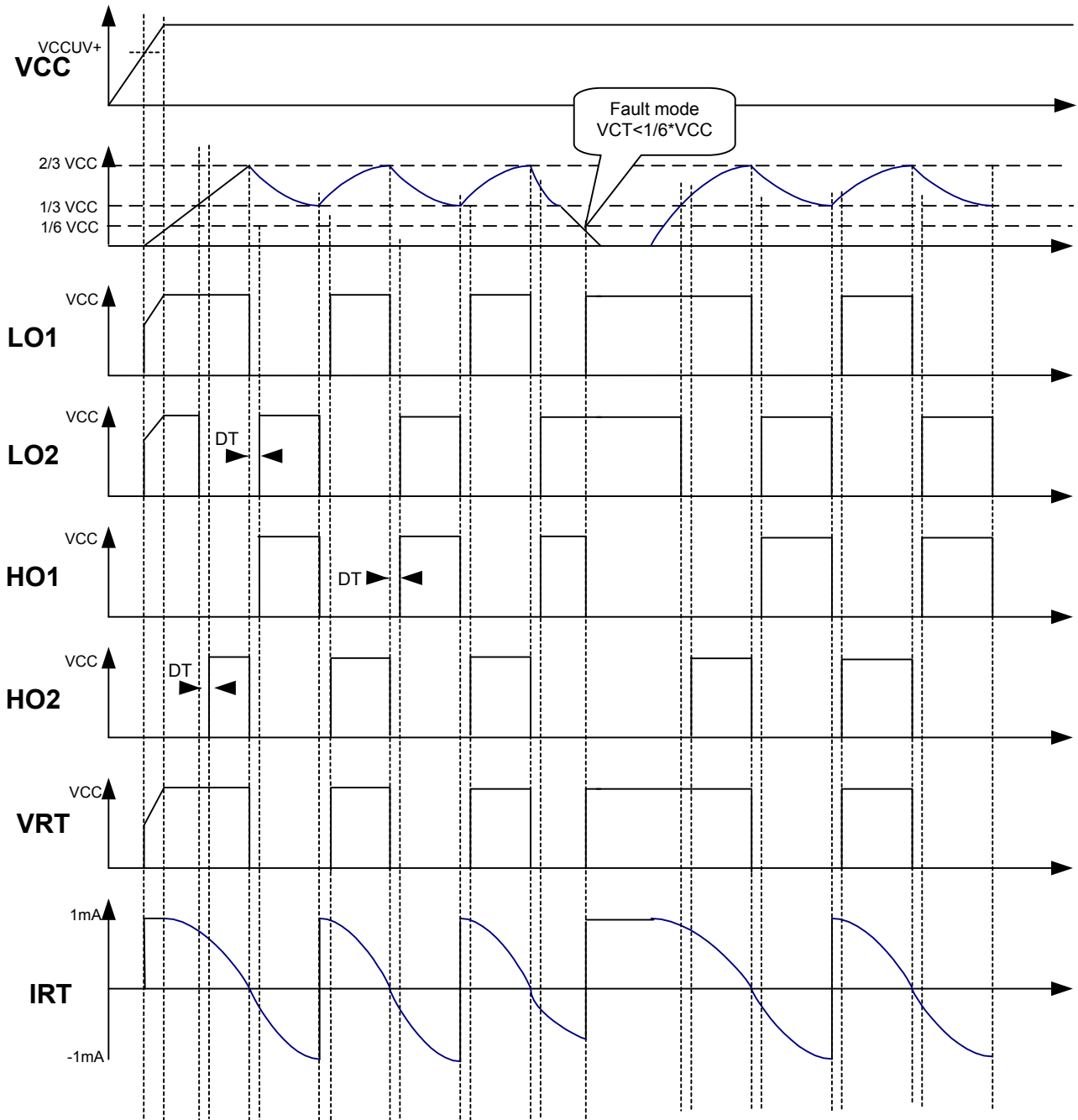

Functional Description

Under-voltage Lock-Out Mode (UVLO)

The under-voltage lockout mode (UVLO) is defined as the state the IC is in when VCC is below the turn-on threshold of the IC. The IRS2453D under voltage lock-out is designed to maintain an ultra low supply current of less than 150uA, and to guarantee the IC is fully functional before the high and low side output drivers are activated. During under voltage lock-out mode, the high and low-side driver outputs LO1, LO2, HO1, HO2 are all low. With VCC above the VCCUV+ threshold, the IC turns on and the output begin to oscillate.

Normal operating mode

Once VCC reaches the start-up threshold VCCUV+, the MOSFET M1 opens, RT increases to approximately VCC (VCC-VRT+) and the external CT capacitor starts charging. Once the CT voltage reaches VCT- (about 1/3 of VCC), established by an internal resistor ladder, LO1 and HO2 turn on with a delay equivalent to the deadtime td. Once the CT voltage reaches VCT+ (approximately 2/3 of VCC), LO1 and HO2 go low, RT goes down to approximately ground (VRT-), the CT capacitor starts discharging and the deadtime circuit is activated. At the end of the deadtime, LO2 and HO1 go high. Once the CT voltage reaches VCT-, LO2 and HO1 go low, RT goes to high again, the deadtime is activated. At the end of the deadtime, LO1 and HO2 go high and the cycle starts over again.

The frequency is best determined by the graph, Frequency vs. RT, Page 3, for different values of CT. A first order approximate of the oscillator frequency can also be calculated by the following formula::

$$f \approx \frac{1}{1.453 \times RT \times CT}$$

This equation can vary slightly from actual measurements due to internal comparator over- and under-shoot delays.

Bootstrap MOSFET

The internal bootstrap FET and supply capacitor (C_{BOOT}) comprise the supply voltage for the high side driver circuitry. The internal bootstrap FET only turns on when the corresponding LO is high. To guarantee that the high-side supply is charged up before the first pulse on HO1 and HO2, LO1 and LO2 are both on when CT ramps between zero and 1/3*VCC. LO1 and LO2 are also on when CT is grounded below 1/6*VCC to ensure that the bootstrap capacitor is charged when CT is brought back over 1/3*VCC.

Non-latched Shutdown

If CT is pulled down below V_{CTSD} (approximately 1/6 of VCC) by an external circuit, CT doesn't charge up and oscillation stops. All outputs are held low and the bootstrap FETs are off. Oscillation will resume once CT is able to charge up again to VCT-.

Latched Shutdown

When the SD pin is brought above 2V, the IC goes into fault mode and all outputs are low. VCC has to be recycled below VCCUV- to restart the IC. The SD pin can be used for over-current or over-voltage protection using appropriate external circuitry.

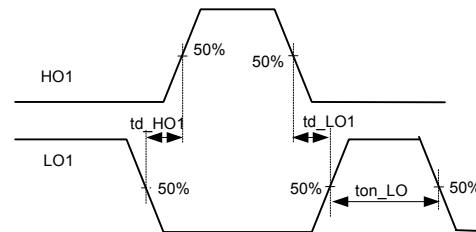

Deadtime Waveform Definitions

Deadtime waveform

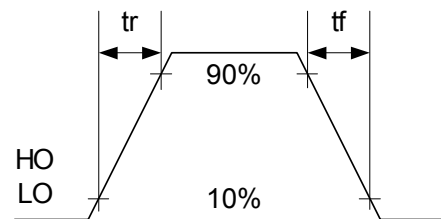

Rise and fall time waveform

IRS2453D

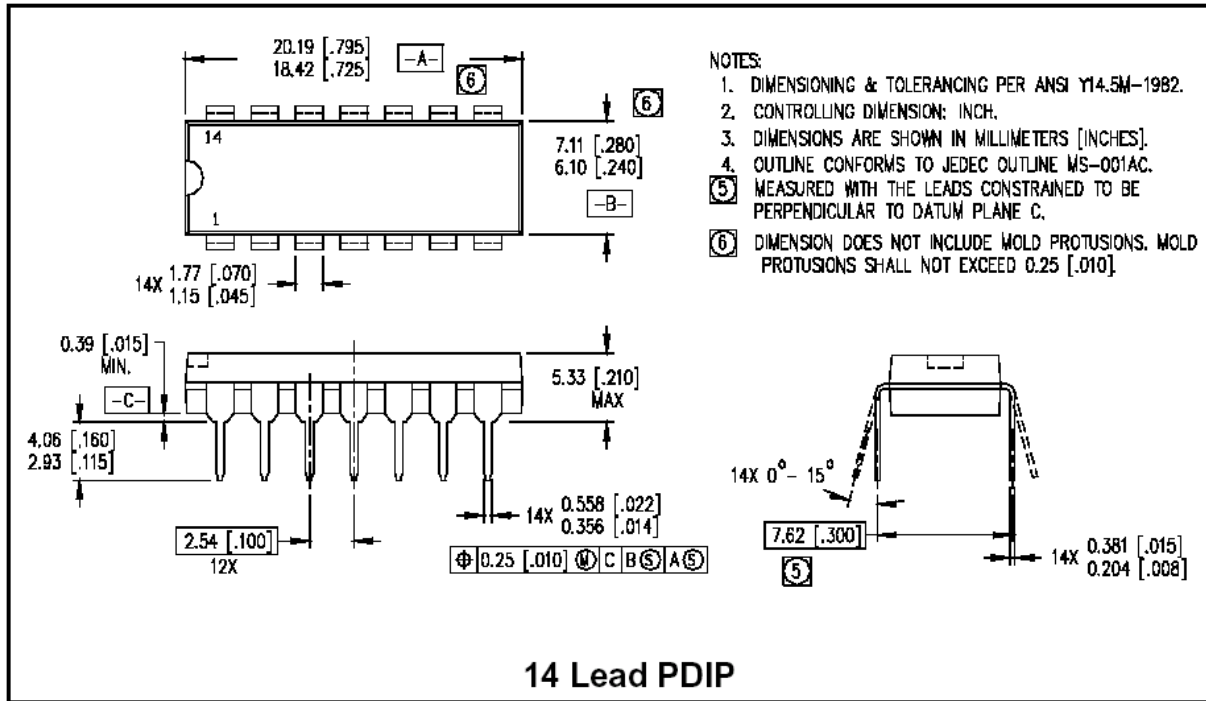

IRS2453DS

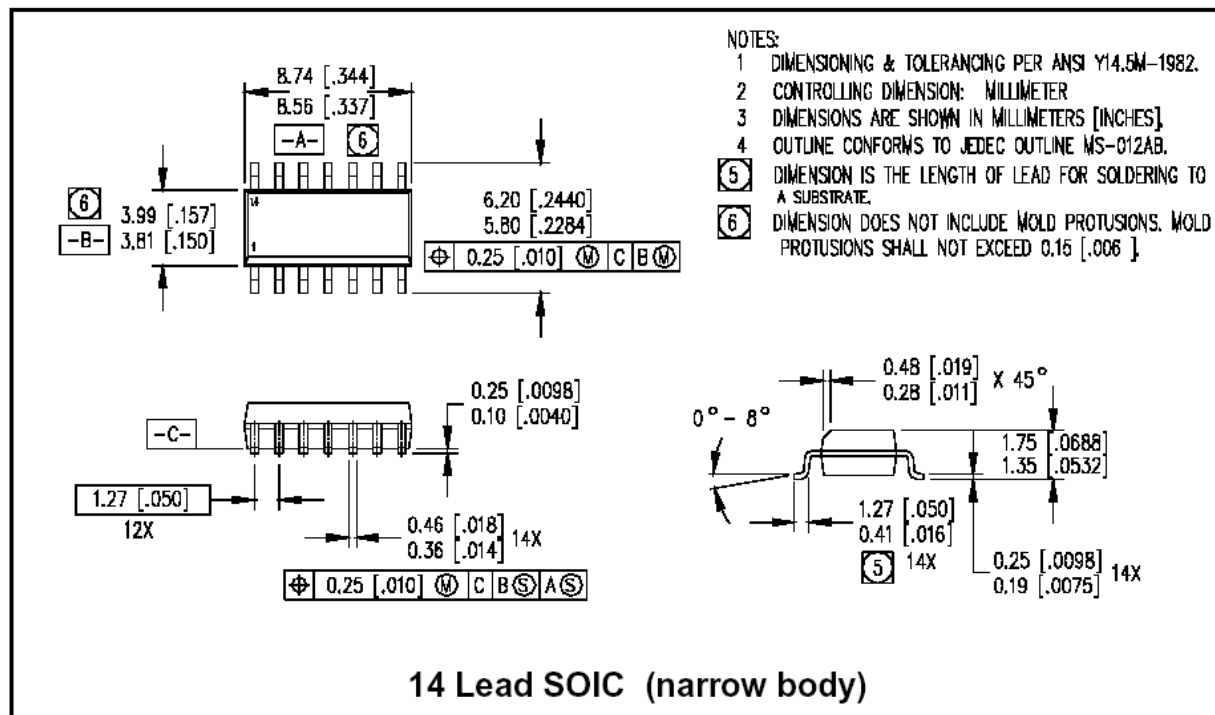

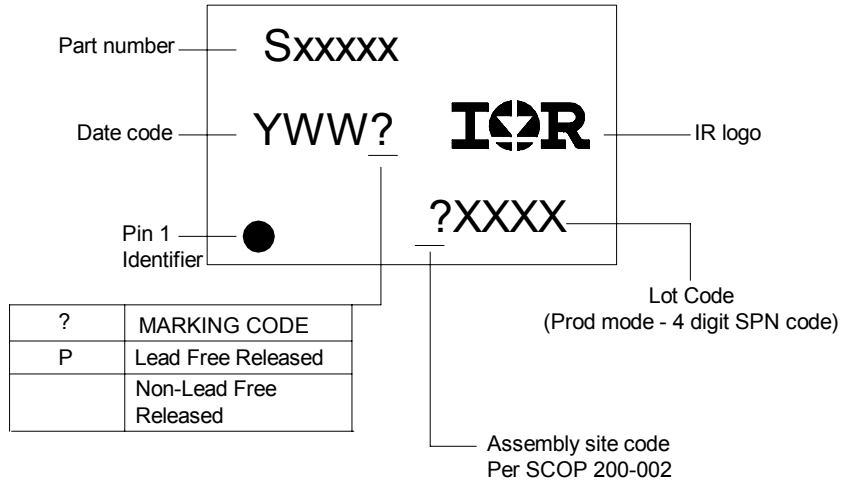

ORDER INFORMATION

8-lead PDIP: order IRS2453DPbF
 8-lead SOICN: order IRS2453DSPbF
 8-lead SOICN tape & reel: order IRS2453DSTRPbF