



0.8Ω, Low-Voltage, Single-Supply SPDT Analog Switch in SC70

MAX4714

General Description

The MAX4714 is a low on-resistance, low-voltage single-pole/double-throw (SPDT) analog switch that operates from a single +1.6V to +3.6V supply. The MAX4714 has break-before-make switching. This device also has fast switching speeds ($t_{ON} = 18\text{ns}$ max, $t_{OFF} = 12\text{ns}$ max).

When powered from a +3V supply, the MAX4714 features 0.8Ω max on-resistance (R_{ON}), with 0.18Ω max R_{ON} matching and flatness. The digital logic input is 1.8V CMOS compatible when using a single +3V supply.

The MAX4714 is pin compatible with the MAX4599 and is available in a 6-pin SC70 package.

Features

- ◆ **Low R_{ON}**
0.8Ω max (+3V Supply)
2.5Ω max (+1.8V Supply)
- ◆ **0.18Ω max R_{ON} Flatness (+3V Supply)**
- ◆ **+1.6V to +3.6V Single-Supply Operation**
- ◆ **Available in 6-Pin SC70 Package**
- ◆ **Fast Switching: $t_{ON} = 18\text{ns}$ max, $t_{OFF} = 12\text{ns}$ max**
- ◆ **1.8V CMOS Logic Compatible (+3V Supply)**
- ◆ **Pin Compatible with MAX4599**
- ◆ **Guaranteed Break-Before-Make**

Applications

- Power Routing
- Battery-Operated Equipment
- Audio and Video Signal Routing
- Low-Voltage Data-Acquisition Systems
- Communications Circuits
- PCMCIA Cards
- Cellular Phones
- Modems
- Hard Drives

Ordering Information

PART	TEMP. RANGE	PIN-PACKAGE	TOP MARK
MAX4714EXT-T	-40°C to +85°C	6 SC70-6	AAY

Pin Configuration/ Functional Diagram/Truth Table

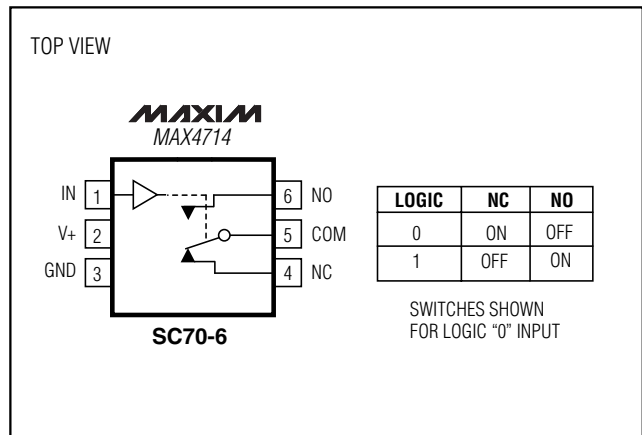

0.8Ω, Low-Voltage, Single-Supply SPDT Analog Switch in SC70

ABSOLUTE MAXIMUM RATINGS

Voltages Referenced to GND

V+, IN	-0.3V to +4V
COM, NC, NO (Note 1).....	-0.3V to (V+ + 0.3V)
Continuous Current NO, NC to COM.....	±150mA
Peak Current NO, NC to COM (pulsed at 1ms, 10% duty cycle max)	±300mA

Continuous Power Dissipation

6-Pin SC70 (derate 3.1mW/°C above +70°C).....	247mW
Operating Temperature Range MAX4714EXT	-40°C to +85°C
Junction Temperature	+150°C
Storage Temperature Range	-65°C to +150°C
Lead Temperature (soldering, 10s)	+300°C

Note 1: Signals on NC, NO, and COM exceeding V+ or GND are clamped by internal diodes.

Stresses beyond those listed under "Absolute Maximum Ratings" may cause permanent damage to the device. These are stress ratings only, and functional operation of the device at these or any other conditions beyond those indicated in the operational sections of the specifications is not implied. Exposure to absolute maximum rating conditions for extended periods may affect device reliability.

ELECTRICAL CHARACTERISTICS—Single +3V Supply

(V+ = +2.7V to +3.6V, V_{IH} = +1.4V, V_{IL} = +0.5V, T_A = T_{MIN} to T_{MAX}, unless otherwise noted. Typical values are at V+ = +3.0V and T_A = +25°C.) (Notes 2, 3)

PARAMETER	SYMBOL	CONDITIONS	T _A	MIN	TYP	MAX	UNITS
ANALOG SWITCH							
Analog Signal Range	V _{COM} , V _{NO} , V _{NC}			0		V+	V
On-Resistance	R _{ON}	V+ = 2.7V, I _{COM} = 100mA, V _{NO} or V _{NC} = 1.5V	+25°C T _{MIN} to T _{MAX}		0.6 0.8		Ω
On-Resistance Match Between Channels (Note 4)	ΔR _{ON}	V+ = 2.7V, I _{COM} = 100mA, V _{NO} or V _{NC} = 1.5V	+25°C T _{MIN} to T _{MAX}		0.03 0.06		Ω
On-Resistance Flatness (Note 5)	R _{FLAT(ON)}	V+ = 2.7V, I _{COM} = 100mA, V _{NO} or V _{NC} = 0.6V, 1.5V, 2.1V	+25°C T _{MIN} to T _{MAX}		0.1 0.18		Ω
NO or NC Off-Leakage Current	I _{NO(OFF)} , I _{NC(OFF)}	V+ = 3.3V, V _{COM} = 0.3V, 3V, V _{NO} or V _{NC} = 3V, 0.3V	+25°C T _{MIN} to T _{MAX}	-1 -5		1 5	nA
COM On-Leakage Current	I _{COM(ON)}	V+ = 3.3V, V _{COM} = 0.3V, 3V, V _{NO} or V _{NC} = 0.3V, 3V or floating	+25°C T _{MIN} to T _{MAX}	-2 -10		2 10	nA
DYNAMIC							
Turn-On Time	t _{ON}	V _{NO} or V _{NC} = 1.5V, R _L = 50Ω, C _L = 35pF, Figure 1	+25°C T _{MIN} to T _{MAX}		13 18		ns
Turn-Off Time	t _{OFF}	V _{NO} or V _{NC} = 1.5V, R _L = 50Ω, C _L = 35pF, Figure 1	+25°C T _{MIN} to T _{MAX}		6 12		ns
Break-Before-Make Delay (Note 6)	t _{BBM}	V _{NO} or V _{NC} = 1.5V, R _L = 50Ω, C _L = 35pF, Figure 2	+25°C T _{MIN} to T _{MAX}	1 1	9		ns
Charge Injection	Q	V _{GEN} , R _{GEN} , C _L = 1.0nF, Figure 3	+25°C		22		pC
Off-Isolation (Note 7)	V _{ISO}	f = 1MHz, V _{COM} = 1V _{RMS} , R _L = 50Ω, C _L = 5pF, Figure 4	+25°C		-54		dB
Crosstalk (Note 8)		f = 1MHz, V _{COM} = 1V _{RMS} , R _L = 50Ω, C _L = 5pF, Figure 4	+25°C		-54		dB
Total Harmonic Distortion	THD	f = 20Hz to 20kHz, V _{COM} = 2V _{P-P} , R _L = 32Ω	+25°C		0.01		%

0.8Ω, Low-Voltage, Single-Supply SPDT Analog Switch in SC70

MAX4714

ELECTRICAL CHARACTERISTICS—Single +3V Supply (continued)

(V+ = +2.7V to +3.6V, V_{IH} = +1.4V, V_{IL} = +0.5V, T_A = T_{MIN} to T_{MAX}, unless otherwise noted. Typical values are at V+ = +3.0V and T_A = +25°C.) (Notes 2, 3)

PARAMETER	SYMBOL	CONDITIONS	T _A	MIN	TYP	MAX	UNITS
NC or NO Off-Capacitance	C _{NO(OFF)} , C _{NC(OFF)}	f = 1MHz, Figure 5	+25°C		30		pF
COM On-Capacitance	C _{COM(ON)}	f = 1MHz, Figure 5	+25°C		65		pF
LOGIC INPUT							
Input Voltage Low	V _{IL}					0.5	V
Input Voltage High	V _{IH}			1.4			V
Input Leakage Current	I _{IN}	V _{IN} = 0 or V+		-1		1	μA
SUPPLY							
Power-Supply Range	V+			1.6		3.6	V
Positive Supply Current	I+	V+ = +3.6V, V _{IN} = 0 or V+	+25°C		0.04	0.2	μA
			T _{MIN} to T _{MAX}			2	

ELECTRICAL CHARACTERISTICS—Single +1.8V Supply

(V+ = +1.8V, V_{IH} = +1V, V_{IL} = +0.4V, T_A = T_{MIN} to T_{MAX}, unless otherwise noted. Typical values are at T_A = +25°C.) (Notes 2, 3)

PARAMETER	SYMBOL	CONDITIONS	T _A	MIN	TYP	MAX	UNITS
ANALOG SWITCH							
Analog Signal Range	V _{COM} , V _{NO} , V _{NC}			0		V+	V
On-Resistance	R _{ON}	I _{COM} = 10mA, V _{NO} or V _{NC} = +0.9V	+25°C		1.2	2.5	Ω
			T _{MIN} to T _{MAX}			5	
NO or NC Off-Leakage Current	I _{NO(OFF)} , I _{NC(OFF)}	V _{COM} = 0.3V, 1.5V, V _{NO} or V _{NC} = 1.5V, 0.3V	+25°C	-1	0.01	1	nA
			T _{MIN} to T _{MAX}	-5		5	
COM On-Leakage Current	I _{COM(ON)}	V _{COM} = 0.3V, 1.5V, V _{NO} or V _{NC} = 0.3V, 1.5V or floating	+25°C	-2		2	nA
			T _{MIN} to T _{MAX}	-10		10	
DYNAMIC							
Turn-On Time	t _{ON}	V _{NO} or V _{NC} = 1.5V, R _L = 50Ω, C _L = 35pF, Figure 1	+25°C		18	25	ns
			T _{MIN} to T _{MAX}			30	
Turn-Off Time	t _{OFF}	V _{NO} or V _{NC} = 1.5V, R _L = 50Ω, C _L = 35pF, Figure 1	+25°C		9	15	ns
			T _{MIN} to T _{MAX}			18	
Break-Before-Make Delay (Note 6)	t _{BBM}	V _{NO} or V _{NC} = 1.5V, R _L = 50Ω, C _L = 35pF, Figure 2	+25°C	2			ns
			T _{MIN} to T _{MAX}	2			
Charge Injection	Q	V _{GEN} = 0, R _{GEN} = 0, C _L = 1nF, Figure 3	+25°C		12		pC

0.8Ω, Low-Voltage, Single-Supply SPDT Analog Switch in SC70

ELECTRICAL CHARACTERISTICS—Single +1.8V Supply (continued)

(V+ = +1.8V, V_{IH} = +1V, V_{IL} = +0.4V, T_A = T_{MIN} to T_{MAX}, unless otherwise noted. Typical values are at T_A = +25°C.) (Notes 2, 3)

PARAMETER	SYMBOL	CONDITIONS	T _A	MIN	TYP	MAX	UNITS
LOGIC INPUT							
Input Voltage Low	V _{IL}					0.4	V
Input Voltage High	V _{IH}			1			V
Input Leakage Current	I _{IN}	V _{IN} = 0 or V+				1	μA
SUPPLY							
Positive Supply Current	I+	V _{IN} = 0 or V+	+25°C		0.04	0.2	μA
			T _{MIN} to T _{MAX}			2	

Note 2: The algebraic convention, where the most negative value is a minimum and the most positive value is a maximum, is used in this data sheet.

Note 3: SC70-packaged parts are 100% tested at +25°C. Limits across the full temperature range are guaranteed by design and correlation.

Note 4: ΔRON = RON(MAX) - RON(MIN).

Note 5: Flatness is defined as the difference between the maximum and minimum values of on-resistance as measured over the specified analog signal range.

Note 6: Guaranteed by design.

Note 7: Off-Isolation = 20log₁₀ [V_{COM} / (V_{NC} or V_{NO})], V_{COM} = output, V_{NC} or V_{NO} = input to off switch.

Note 8: Between the two switches.

Typical Operating Characteristics

(T_A = +25°C, unless otherwise noted.)

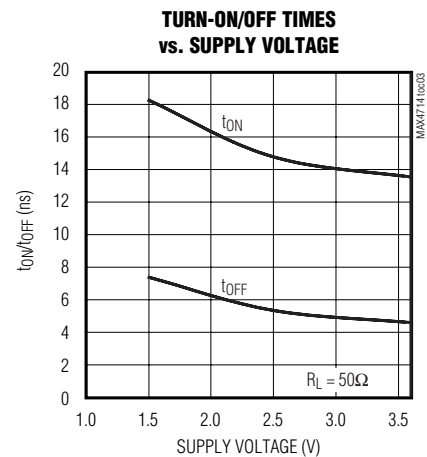
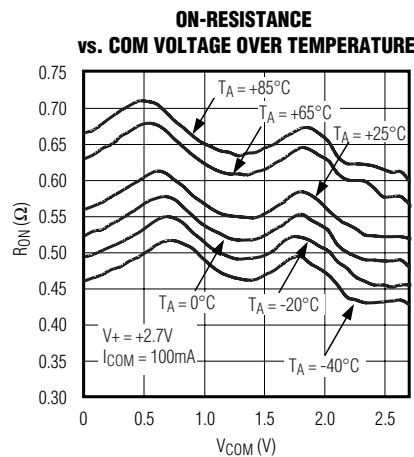
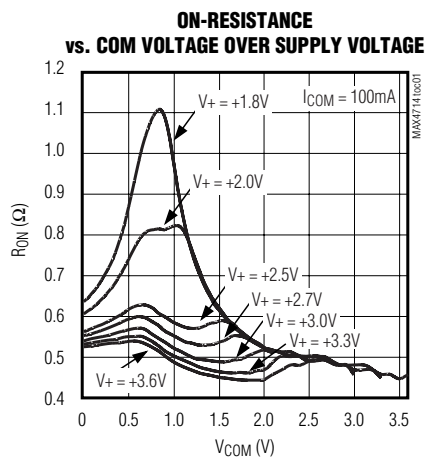

0.8Ω, Low-Voltage, Single-Supply SPDT Analog Switch in SC70

MAX4714

Typical Operating Characteristics (continued)

($T_A = +25^\circ\text{C}$, unless otherwise noted.)

TURN-ON/OFF TIMES vs. TEMPERATURE

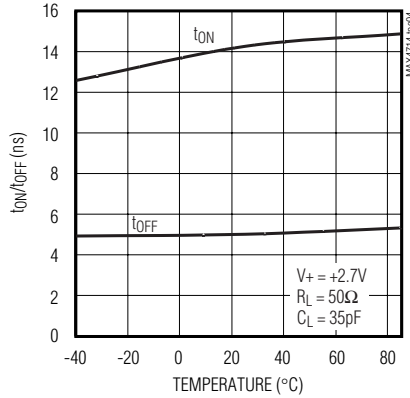

ON/OFF-LEAKAGE CURRENT vs. TEMPERATURE

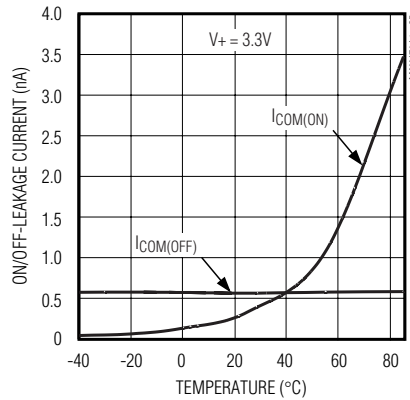

CHARGE INJECTION vs. COM VOLTAGE

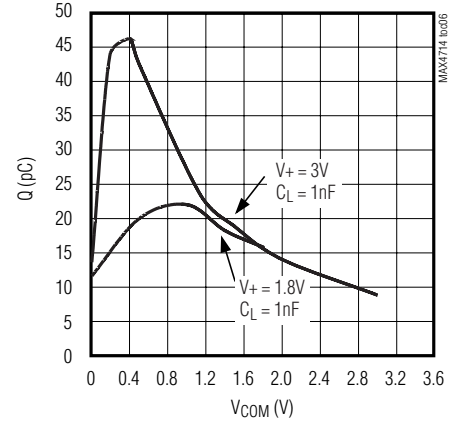

FREQUENCY RESPONSE

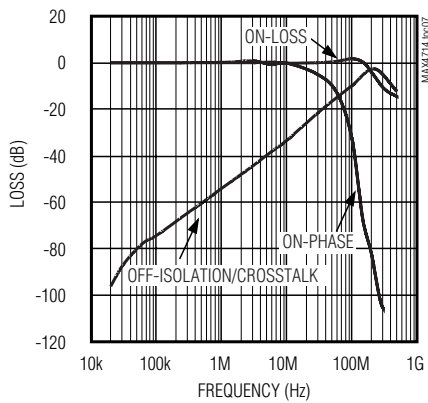

LOGIC THRESHOLD VOLTAGE vs. SUPPLY VOLTAGE

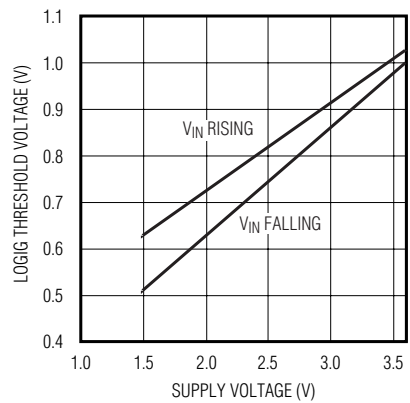

TOTAL HARMONIC DISTORTION vs. FREQUENCY

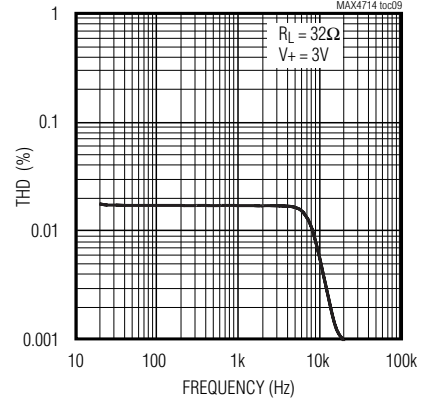

Pin Description

PIN	NAME	FUNCTION
1	IN	Digital Control Input
2	V+	Positive Supply Voltage Input
3	GND	Ground
4	NC	Analog Switch—Normally Closed
5	COM	Analog Switch—Common
6	NO	Analog Switch—Normally Open

0.8Ω, Low-Voltage, Single-Supply SPDT Analog Switch in SC70

Detailed Description

The MAX4714 is a low-on-resistance (R_{ON}), low-voltage, single-pole/double-throw (SPDT) analog switch that operates from a +1.6V to +3.6V supply. The MAX4714 has break-before-make switching. This device also has fast switching speeds ($t_{ON} = 18\text{ns}$ max, $t_{OFF} = 12\text{ns}$ max).

When powered from a +3V supply, the 0.8Ω max R_{ON} allows high continuous currents to be switched in a variety of applications.

Applications Information

Logic Inputs

The MAX4714 logic input can be driven up to +3.6V regardless of the supply voltage. For example, with a

Rail-to-Rail is a registered trademark of Nippon Motorola, Ltd.

+3.3V supply, IN may be driven low to GND and high to +3.6V. Driving IN Rail-to-Rail® minimizes power consumption.

Analog Signal Levels

Analog signals that range over the entire supply voltage (V_+ to GND) can be passed with very little change in on-resistance (see *Typical Operating Characteristics*). The switches are bidirectional, so the NO, NC, and COM pins can be used as either inputs or outputs.

Chip Information

TRANSISTOR COUNT: 135

PROCESS: CMOS

Test Circuits/Timing Diagrams

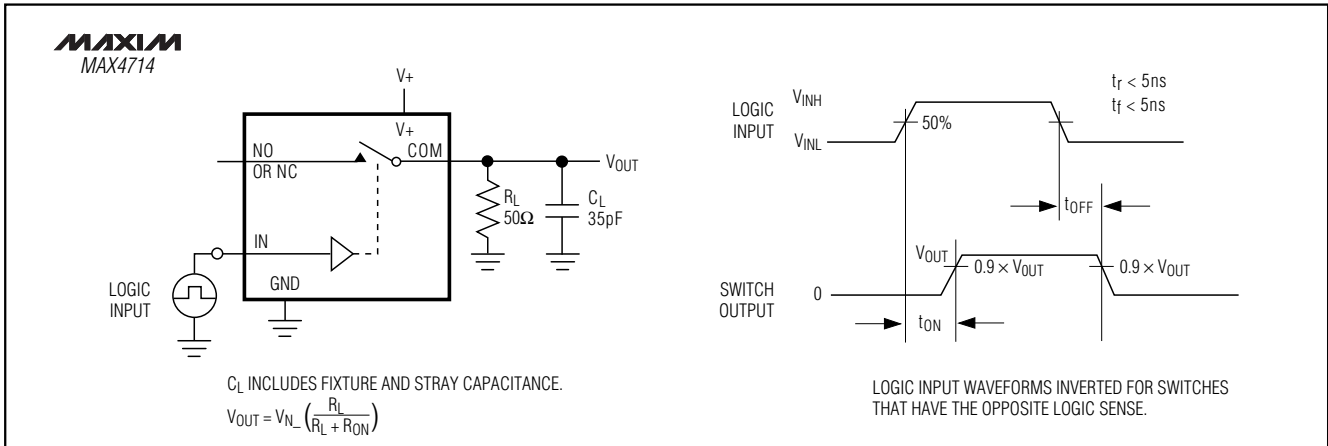

Figure 1. Switching Time

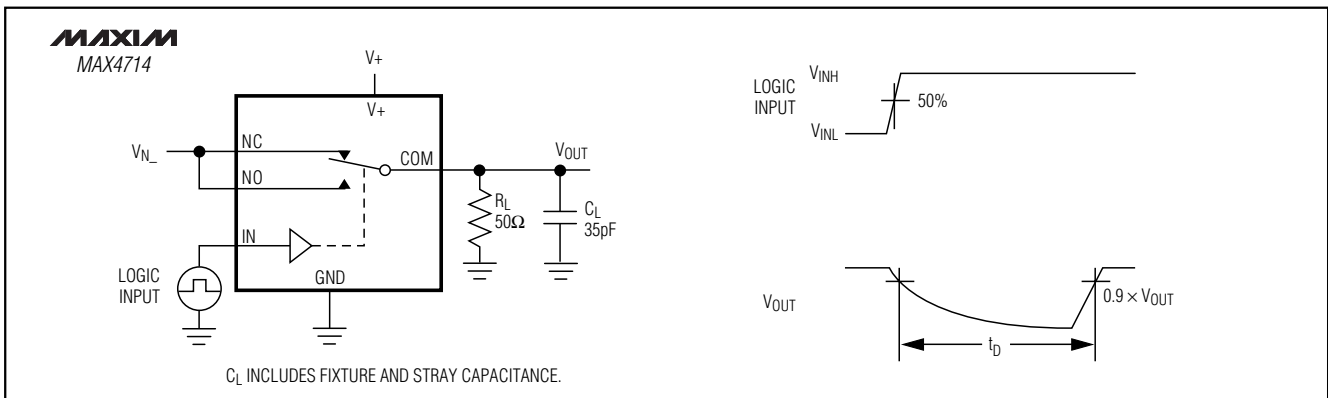

Figure 2. Break-Before-Make Interval

0.8Ω, Low-Voltage, Single-Supply SPDT Analog Switch in SC70

Test Circuits/Timing Diagrams (continued)

MAX4714

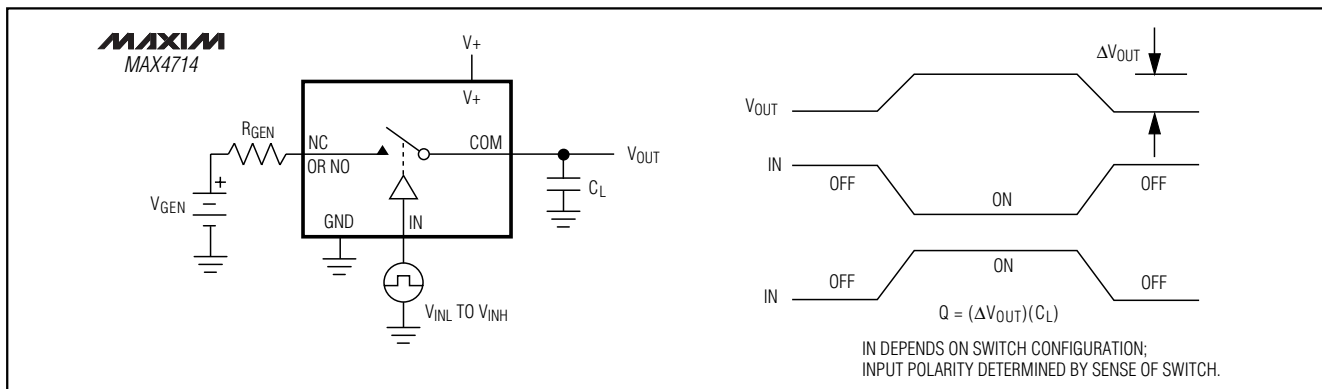

Figure 3. Charge Injection

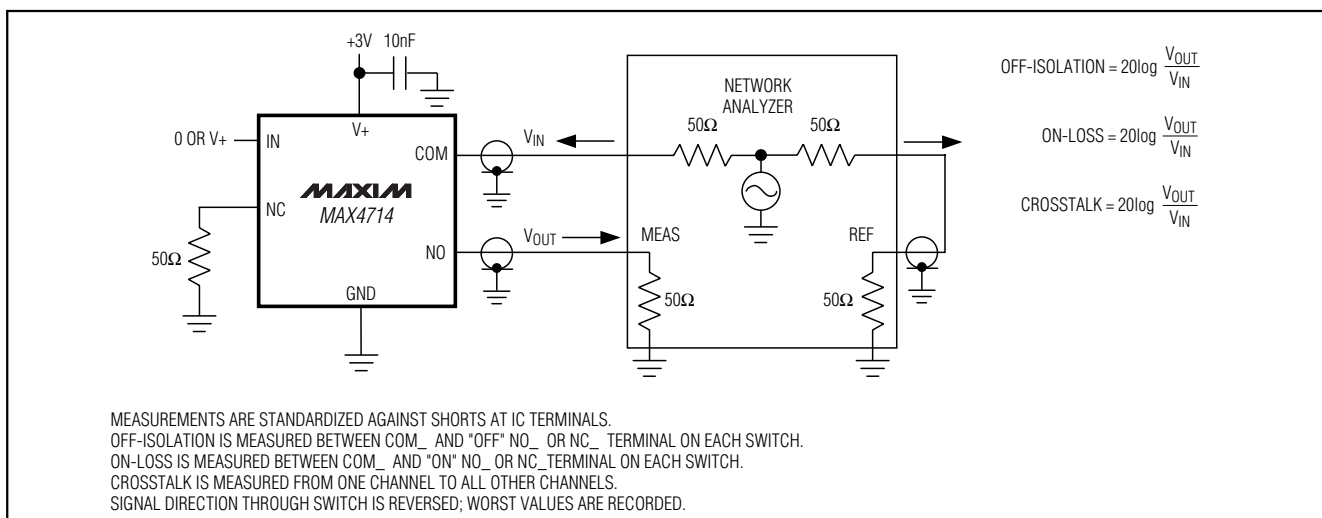

Figure 4. On-Loss, Off-Isolation, and Crosstalk

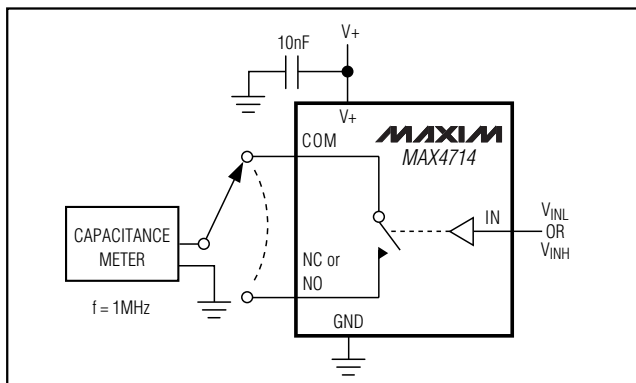
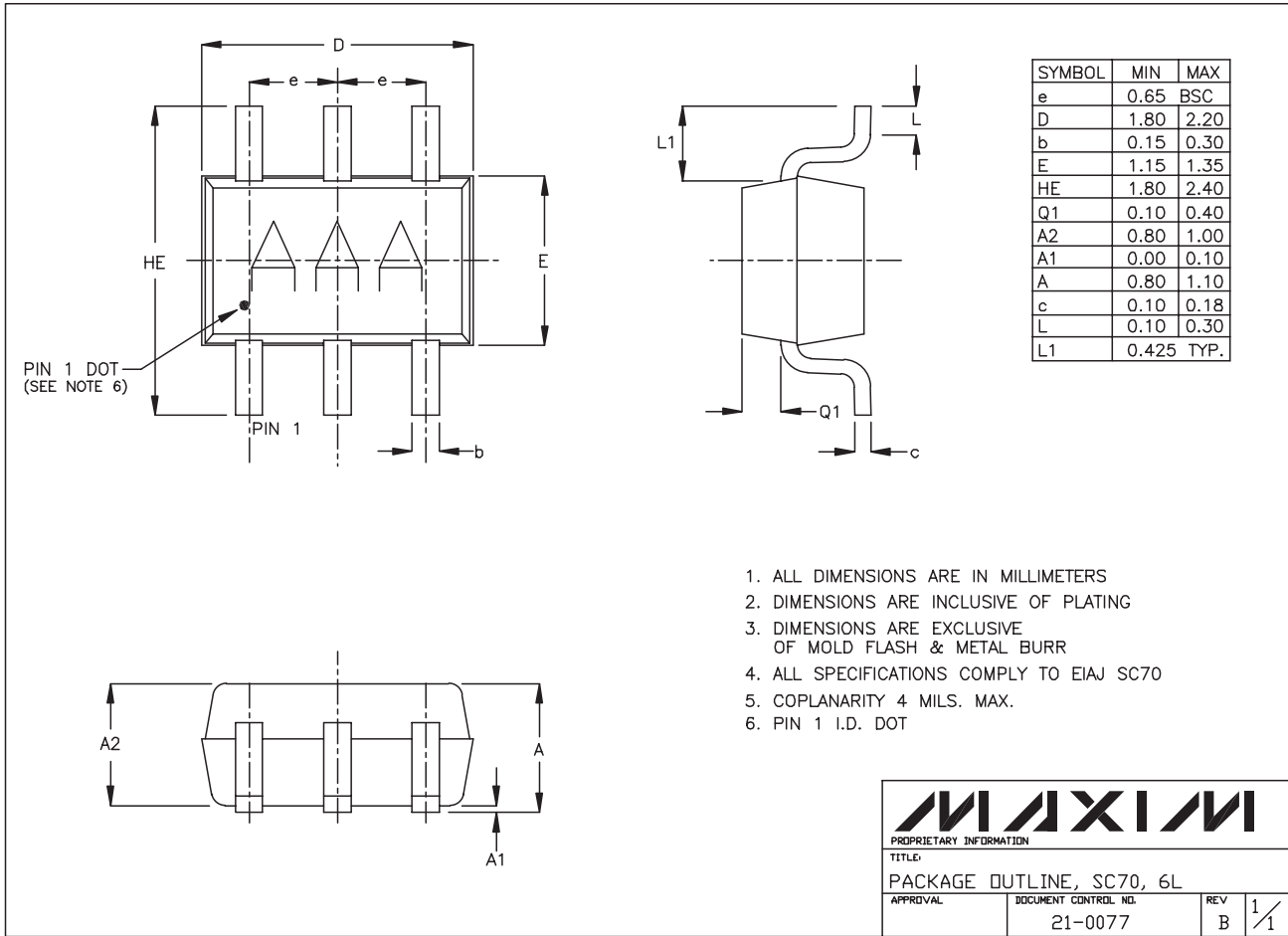

Figure 5. Channel Off/On-Capacitance

0.8Ω, Low-Voltage, Single-Supply SPDT Analog Switch in SC70

Package Information

SC70, 6LEPS



Maxim cannot assume responsibility for use of any circuitry other than circuitry entirely embodied in a Maxim product. No circuit patent licenses are implied. Maxim reserves the right to change the circuitry and specifications without notice at any time.

8 Maxim Integrated Products, 120 San Gabriel Drive, Sunnyvale, CA 94086 408-737-7600