

Low Cost, Miniature Fiber Optic Components with ST[®], SMA, SC and FC Ports

Technical Data

Features

- Meets IEEE 802.3 Ethernet and 802.5 Token Ring Standards
- Low Cost Transmitters and Receivers
- Choice of ST[®], SMA, SC or FC Ports
- 820 nm Wavelength Technology
- Signal Rates up to 160 Megabaud
- Link Distances up to 2.7 km
- Specified with 50/125 μm , 62.5/125 μm , 100/140 μm , and 200 μm HCS[®] Fiber
- Repeatable ST Connections within 0.2 dB Typical
- Unique Optical Port Design for Efficient Coupling
- Auto-Insertable and Wave Solderable
- No Board Mounting Hardware Required
- Wide Operating Temperature Range -40°C to 85°C
- AlGaAs Emitters 100% Burn-In Ensures High Reliability
- Conductive Port Option

Applications

- Local Area Networks
- Computer to Peripheral Links
- Computer Monitor Links
- Digital Cross Connect Links
- Central Office Switch/PBX Links
- Video Links
- Modems and Multiplexers
- Suitable for Tempest Systems
- Industrial Control Links

Description

The HFBR-0400 Series of components is designed to provide cost effective, high performance fiber optic communication links for information systems and industrial applications with link distances of up to 2.7 kilometers. With the HFBR-24X6, the 125 MHz analog receiver, data rates of up to 160 megabaud are attainable.

HFBR-0400 Series HFBR-14xx Transmitters HFBR-24xx Receivers

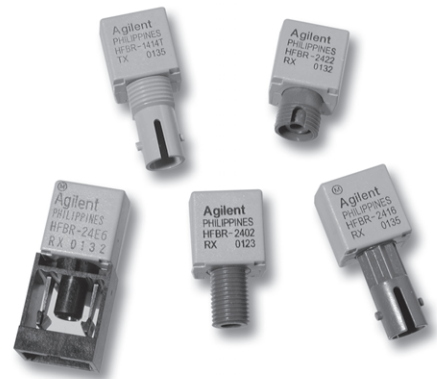

Transmitters and receivers are directly compatible with popular "industry-standard" connectors: ST, SMA, SC and FC. They are completely specified with multiple fiber sizes; including 50/125 μm , 62.5/125 μm , 100/140 μm , and 200 μm .

Complete evaluation kits are available for ST product offerings; including transmitter, receiver, connected cable, and technical literature. In addition, ST connected cables are available for evaluation.

ST[®] is a registered trademark of AT&T.

HCS[®] is a registered trademark of the SpecTran Corporation.

HFBR-0400 Series Part Number Guide

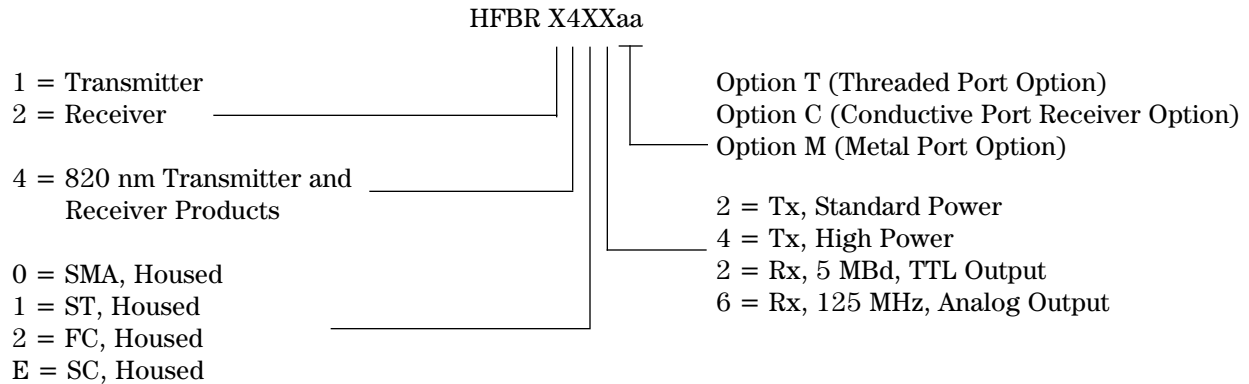

Available Options

HFBR-1402	HFBR-1414	HFBR-1412TM	HFBR-2412TC	HFBR-2412T	HFBR-2416TC
HFBR-1404	HFBR-1414M	HFBR-14E4	HFBR-2416	HFBR-2422	
HFBR-1412	HFBR-1414T	HFBR-2402	HFBR-2416M	HFBR-24E6	
HFBR-1412T	HFBR-1424	HFBR-2406	HFBR-2412	HFBR-2416T	

LINK SELECTION GUIDE

Data Rate (MBd)	Distance (m)	Transmitter	Receiver	Fiber Size (µm)	Evaluation Kit
5	1500	HFBR-14X2	HFBR-24X2	200 HCS	N/A
5	2000	HFBR-14X4	HFBR-24X2	62.5/125	HFBR-0410
20	2700	HFBR-14X4	HFBR-24X6	62.5/125	HFBR-0414
32	2200	HFBR-14X4	HFBR-24X6	62.5/125	HFBR-0414
55	1400	HFBR-14X4	HFBR-24X6	62.5/125	HFBR-0414
125	700	HFBR-14X4	HFBR-24X6	62.5/125	HFBR-0416
155	600	HFBR-14X4	HFBR-24X6	62.5/125	HFBR-0416
160	500	HFBR-14X4	HFBR-24X6	62.5/125	HFBR-0416

For additional information on specific links see the following individual link descriptions. Distances measured over temperature range from 0 to 70°C.

Applications Support Guide

This section gives the designer information necessary to use the HFBR-0400 series components to

make a functional fiber-optic transceiver. Agilent offers a wide selection of evaluation kits for hands-on experience with fiber-optic products as well as a wide

range of application notes complete with circuit diagrams and board layouts. Furthermore, Agilent's application support group is always ready to assist with any design consideration.

Application Literature

Title	Description
HFBR-0400 Series Reliability Data	Transmitter & Receiver Reliability Data
Application Bulletin 78	Low Cost Fiber Optic Links for Digital Applications up to 155 MBd
Application Note 1038	Complete Fiber Solutions for IEEE 802.3 FOIRL, 10Base-FB and 10 Base-FL
Application Note 1065	Complete Solutions for IEEE 802.5J Fiber-Optic Token Ring
Application Note 1073	HFBR-0319 Test Fixture for 1X9 Fiber Optic Transceivers
Application Note 1086	Optical Fiber Interconnections in Telecommunication Products
Application Note 1121	DC to 32 MBd Fiber-Optic Solutions
Application Note 1122	2 to 70 MBd Fiber-Optic Solutions
Application Note 1123	20 to 160 MBd Fiber-Optic Solutions
Application Note 1137	Generic Printed Circuit Layout Rules

HFBR-0400 Series Evaluation Kits

HFBR-0410 ST Evaluation Kit

Contains the following :

- One HFBR-1412 transmitter
- One HFBR-2412 five megabaud TTL receiver
- Three meters of ST connected 62.5/125 (μm fiber optic cable with low cost plastic ferrules.
- Related literature

HFBR-0414 ST Evaluation Kit

Includes additional components to interface to the transmitter and receiver as well as the PCB to reduce design time.

Contains the following:

- One HFBR-1414T transmitter
- One HFBR-2416T receiver
- Three meters of ST connected 62.5/125 μm fiber optic cable
- Printed circuit board
- ML-4622 CP Data Quantizer
- 74ACT11000N LED Driver
- LT1016CN8 Comparator
- 4.7 μH Inductor
- Related literature

HFBR-0400 SMA Evaluation Kit

Contains the following :

- One HFBR-1402 transmitter
- One HFBR-2402 five megabaud TTL receiver
- Two meters of SMA connected 1000 μm plastic optical fiber
- Related literature

HFBR-0416 Evaluation Kit

Contains the following:

- One fully assembled 1x9 transceiver board for 155 MBd evaluation including:
 - HFBR-1414 transmitter
 - HFBR-2416 receiver
 - circuitry
- Related literature

Package and Handling Information

Package Information

All HFBR-0400 Series transmitters and receivers are housed in a low-cost, dual-inline package that is made of high strength, heat resistant, chemically resistant, and UL 94V-0 flame retardant ULTEM[®] (plastic (UL File #E121562)). The transmitters are easily identified by the light grey color connector port. The receivers are easily identified by the dark grey color connector port. (Black color for conductive port.) The package is designed for auto-insertion and wave soldering so it is ideal for high volume production applications.

Handling and Design Information

Each part comes with a protective port cap or plug covering the optics. These caps/plugs will vary by port style. When soldering, it is advisable to leave the protective cap on the unit to keep the optics clean. Good system performance requires clean port optics and cable ferrules to avoid obstructing the optical path.

Clean compressed air often is sufficient to remove particles of dirt; methanol on a cotton swab also works well.

Recommended Chemicals for Cleaning/Degreasing HFBR-0400 Products

Alcohols: methyl, isopropyl, isobutyl. Aliphatics: hexane, heptane, Other: soap solution, naphtha.

Do not use partially halogenated hydrocarbons such as 1,1,1 trichloroethane, ketones such as MEK, acetone, chloroform, ethyl acetate, methylene dichloride, phenol, methylene chloride, or N-methylpyrrolidone. Also, Agilent does not recommend the use of cleaners that use halogenated hydrocarbons because of their potential environmental harm.

Mechanical Dimensions SMA Port HFBR-X40X

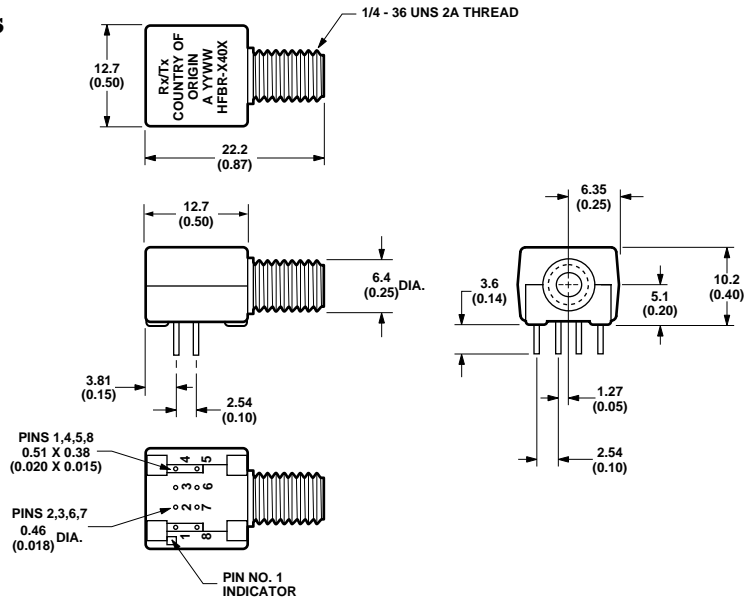

Mechanical Dimensions ST Port HFBR-X41X

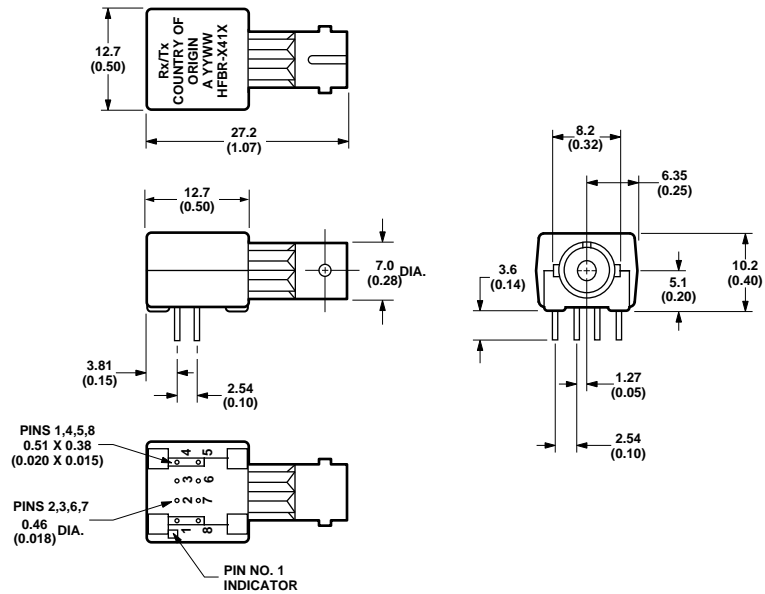

Mechanical Dimensions Threaded ST Port

HFBR-X41XT

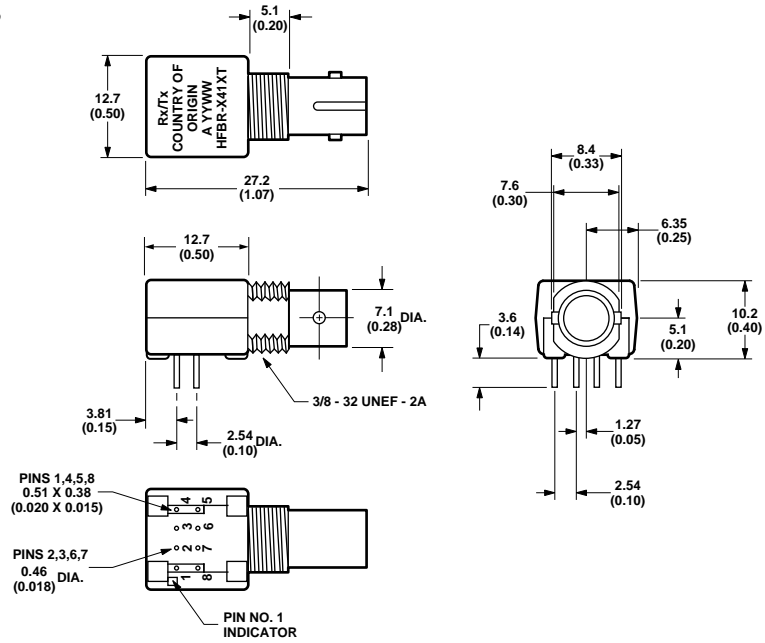

Mechanical Dimensions FC Port

HFBR-X42X

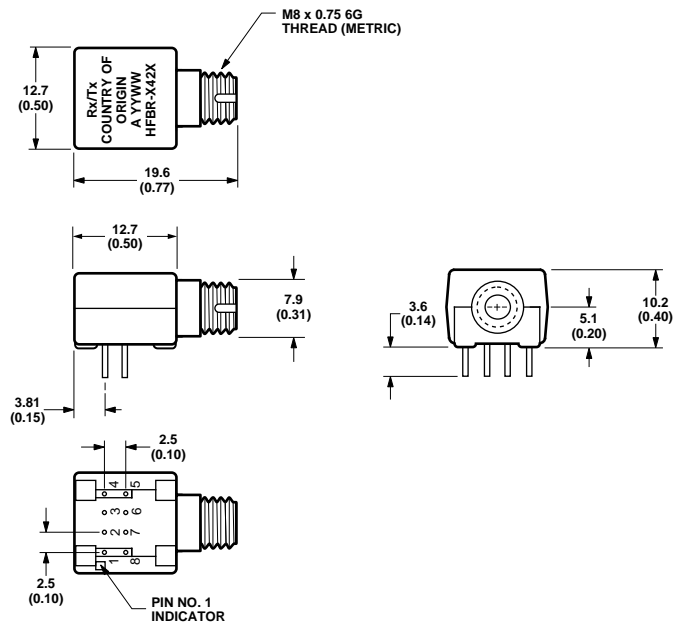

Mechanical Dimensions SC Port

HFBR-X4EX

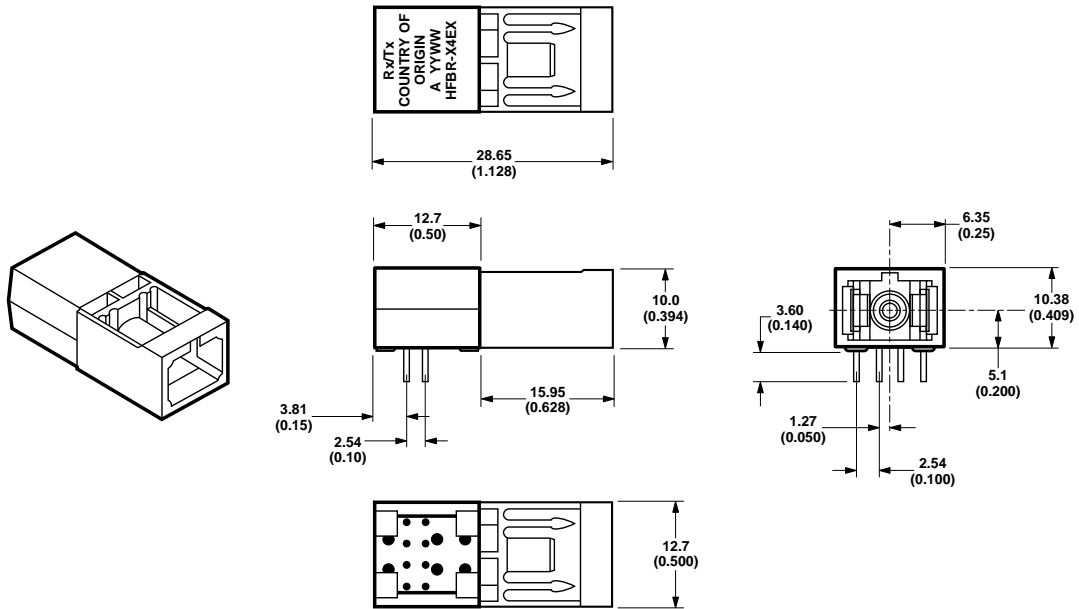

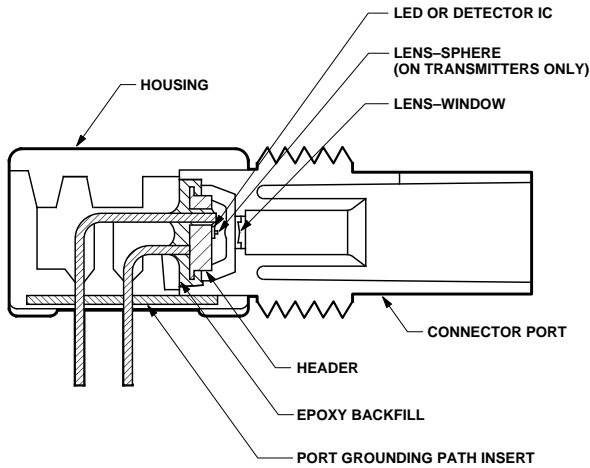
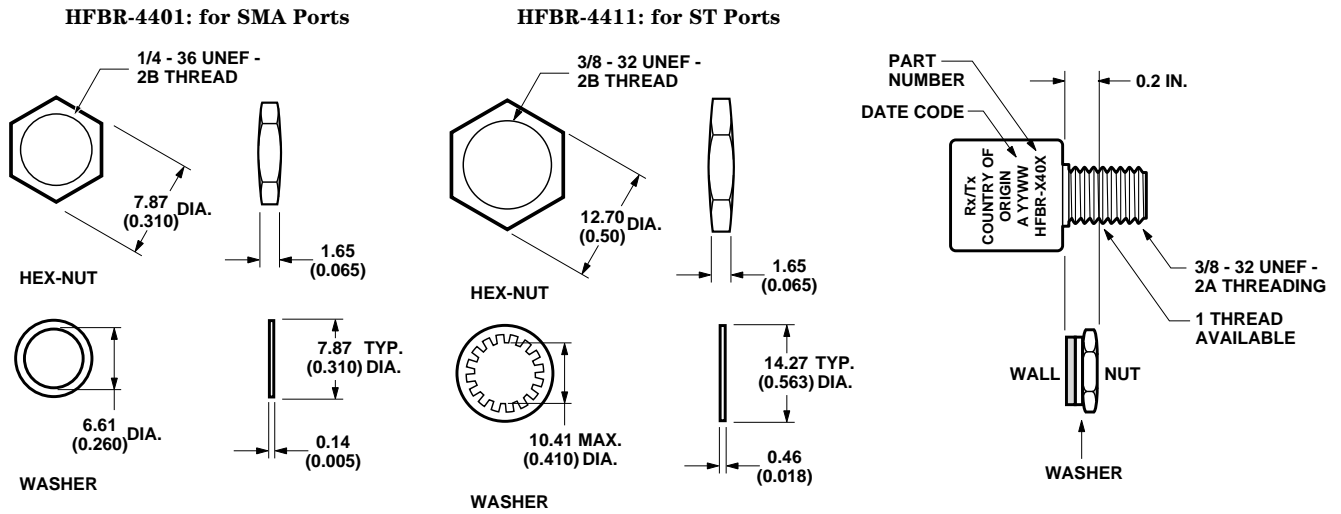

Figure 1. HFBR-0400 ST Series Cross-Sectional View.

Panel Mount Hardware



(Each HFBR-4401 and HFBR-4411 kit consists of 100 nuts and 100 washers.)

Port Cap Hardware

HFBR-4402: 500 SMA Port Caps

HFBR-4120: 500 ST Port Plugs (120 psi)

Options

In addition to the various port styles available for the HFBR-0400 series products, there are also several extra options that can be ordered. To order an option, simply place the corresponding option number at the end of the part number. See page 2 for available options.

Option T (Threaded Port Option)

- Allows ST style port components to be panel mounted.
- Compatible with all current makes of ST multimode connectors
- Mechanical dimensions are compliant with MIL-STD-83522/13
- Maximum wall thickness when using nuts and washers from the HFBR-4411 hardware kit is 2.8 mm (0.11 inch)
- Available on all ST ports

Option C (Conductive Port Receiver Option)

- Designed to withstand electrostatic discharge (ESD) of 25kV to the port
- Significantly reduces effect of electromagnetic interference (EMI) on receiver sensitivity
- Allows designer to separate the signal and conductive port grounds
- Recommended for use in noisy environments
- Available on SMA and threaded ST port style receivers only

Option M (Metal Port Option)

- Nickel plated aluminum connector receptacle
- Designed to withstand electrostatic discharge (ESD) of 15kV to the port
- Significantly reduces effect of electromagnetic interference (EMI) on receiver sensitivity
- Allows designer to separate the signal and metal port grounds
- Recommended for use in very noisy environments
- Available on SMA, ST, and threaded ST ports

Typical Link Data

HFBR-0400 Series

Description

The following technical data is taken from 4 popular links using the HFBR-0400 series: the 5 MBd link, Ethernet 20 MBd link, Token Ring 32 MBd link, and the 155 MBd link. The data given

corresponds to transceiver solutions combining the HFBR-0400 series components and various recommended transceiver design circuits using off-the-shelf electrical components. This data is meant to be regarded as an

example of typical link performance for a given design and does not call out any link limitations. Please refer to the appropriate application note given for each link to obtain more information.

5 MBd Link (HFBR-14XX/24X2)

Link Performance -40°C to +85°C unless otherwise specified

Parameter	Symbol	Min.	Typ.	Max.	Units	Conditions	Reference
Optical Power Budget with 50/125 μm fiber	OPB ₅₀	4.2	9.6		dB	HFBR-14X4/24X2 NA = 0.2	Note 1
Optical Power Budget with 62.5/125 μm fiber	OPB _{62.5}	8.0	15		dB	HFBR-14X4/24X2 NA = 0.27	Note 1
Optical Power Budget with 100/140 μm fiber	OPB ₁₀₀	8.0	15		dB	HFBR-14X2/24X2 NA = 0.30	Note 1
Optical Power Budget with 200 μm fiber	OPB ₂₀₀	12	20		dB	HFBR-14X2/24X2 NA = 0.37	Note 1
Date Rate Synchronous		dc		5	MBd		Note 2
Asynchronous		dc		2.5	MBd		Note 3, Fig. 7
Propagation Delay LOW to HIGH	t _{PLH}		72		ns	T _A = 25°C, P _R = -21 dBm Peak Fiber cable length = 1 m	Figs. 6, 7, 8
Propagation Delay HIGH to LOW	t _{PHL}		46		ns		
System Pulse Width Distortion	t _{PLH} -t _{PHL}		26		ns		
Bit Error Rate	BER			10 ⁻⁹		Data Rate <5 Bd P _R > -24 dBm Peak	

Notes:

- OPB at T_A = -40 to 85°C, V_{CC} = 5.0 V dc, I_{F ON} = 60 mA. P_R = -24 dBm peak.
- Synchronous data rate limit is based on these assumptions: a) 50% duty factor modulation, e.g., Manchester I or BiPhase Manchester II; b) continuous data; c) PLL Phase Lock Loop demodulation; d) TTL threshold.
- Asynchronous data rate limit is based on these assumptions: a) NRZ data; b) arbitrary timing-no duty factor restriction; c) TTL threshold.

5 MBd Logic Link Design

If resistor R_1 in Figure 2 is 70.4Ω , a forward current I_F of 48 mA is applied to the HFBR-14X4 LED transmitter. With $I_F = 48 \text{ mA}$ the HFBR-14X4/24X2 logic link is guaranteed to work with $62.5/125 \mu\text{m}$ fiber optic cable over the entire range of 0 to 1750 meters at a data rate of dc to 5 MBd , with arbitrary data format and pulse width distortion typically less than 25% . By setting $R_1 = 115 \Omega$, the transmitter can be driven with $I_F = 30 \text{ mA}$, if it is desired to economize on power or achieve lower pulse distortion.

The following example will illustrate the technique for selecting the appropriate value of I_F and R_1 .

Maximum distance required = 400 meters. From Figure 3 the drive current should be 15 mA . From the transmitter data $V_F = 1.5 \text{ V (max.)}$ at $I_F = 15 \text{ mA}$ as shown in Figure 9.

$$R_1 = \frac{V_{CC} - V_F}{I_F} = \frac{5 \text{ V} - 1.5 \text{ V}}{15 \text{ mA}}$$

$$R_1 = 233 \Omega$$

The curves in Figures 3, 4, and 5 are constructed assuming no in-line splice or any additional system loss. Should the link consist of any in-line splices, these curves can still be used to calculate link limits provided they are shifted by the additional system loss expressed in dB. For example, Figure 3 indicates that with 48 mA of transmitter drive current, a 1.75 km link distance is achievable with $62.5/125 \mu\text{m}$ fiber which has a maximum attenuation of 4 dB/km . With 2 dB of additional system loss, a 1.25 km link distance is still achievable.

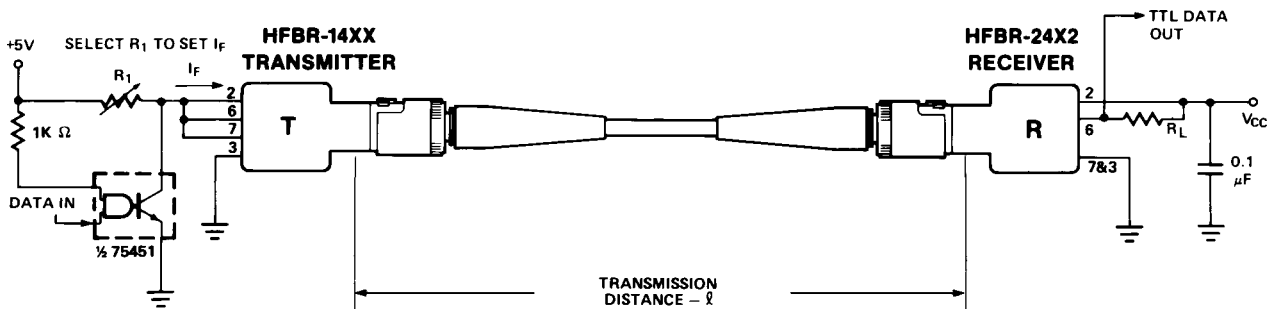

NOTE:
IT IS ESSENTIAL THAT A BYPASS CAPACITOR ($0.01 \mu\text{F}$ TO $0.1 \mu\text{F}$ CERAMIC) BE CONNECTED FROM PIN 2 TO PIN 7 OF THE RECEIVER. TOTAL LEAD LENGTH BETWEEN BOTH ENDS OF THE CAPACITOR AND THE PINS SHOULD NOT EXCEED 20 mm .

Figure 2. Typical Circuit Configuration.

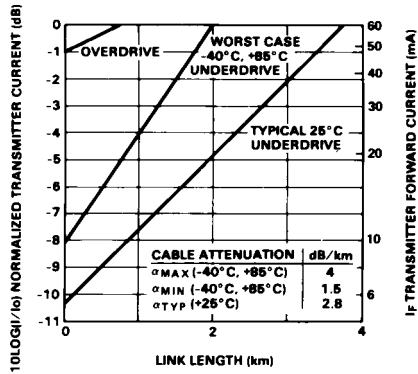

Figure 3. HFBR-1414/HFBR-2412 Link Design Limits with 62.5/125 μm Cable.

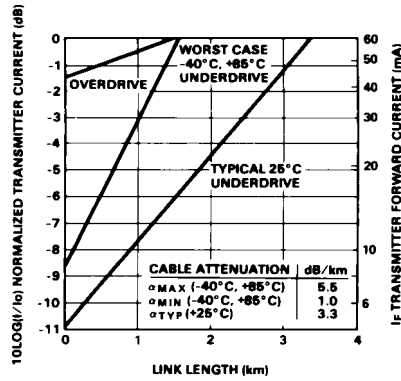

Figure 4. HFBR-14X2/HFBR-24X2 Link Design Limits with 100/140 μm Cable.

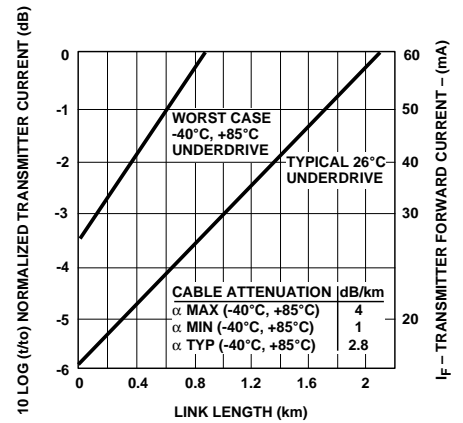

Figure 5. HFBR-14X4/HFBR-24X2 Link Design Limits with 50/125 μm Cable.

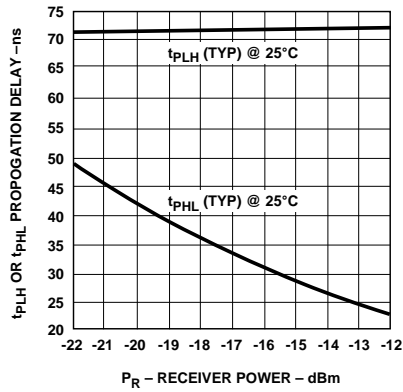

Figure 6. Propagation Delay through System with One Meter of Cable.

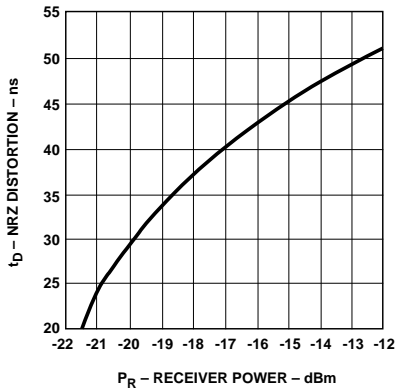

Figure 7. Typical Distortion of Pseudo Random Data at 5 Mb/s.

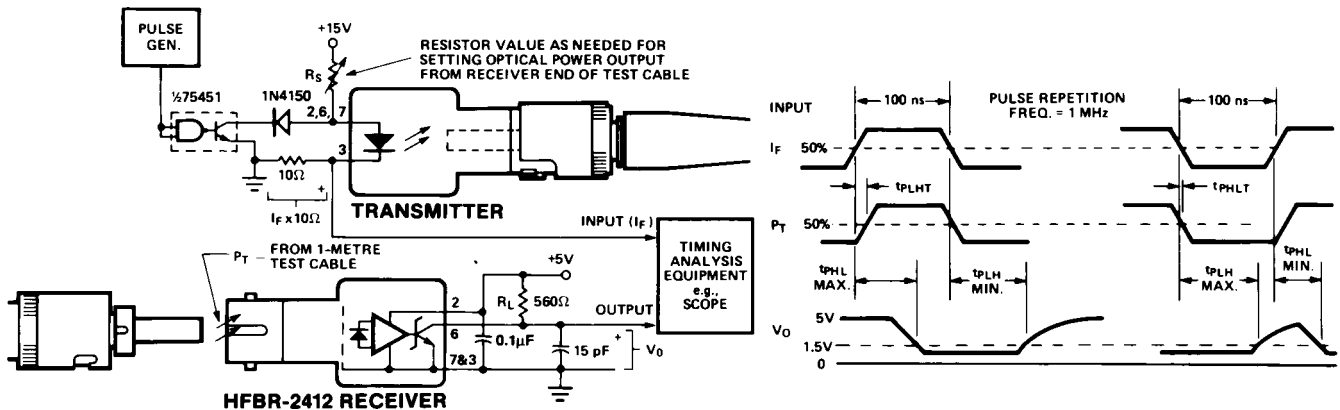

Figure 8. System Propagation Delay Test Circuit and Waveform Timing Definitions.

Ethernet 20 MBd Link (HFBR-14X4/24X6)

(refer to Application Note 1038 for details)

Typical Link Performance

Parameter	Symbol	Typ. ^[1,2]	Units	Conditions
Receiver Sensitivity		-34.4	dBm average	20 MBd D2D2 Hexadecimal Data 2 km 62.5/125 μ m fiber
Link Jitter		7.56	ns pk-pk	ECL Out Receiver
		7.03	ns pk-pk	TTL Out Receiver
Transmitter Jitter		0.763	ns pk-pk	20 MBd D2D2 Hexadecimal Data
Optical Power	P_T	-15.2	dBm average	20 MBd D2D2 Hexadecimal Data Peak $I_{F,ON} = 60$ mA
LED rise time	t_r	1.30	ns	1 MHz Square Wave Input
LED fall time	t_f	3.08	ns	
Mean difference	$ t_r - t_f $	1.77	ns	
Bit Error Rate	BER	10^{-10}		
Output Eye Opening		36.7	ns	At AUI Receiver Output
Data Format 50% Duty Factor		20	MBd	

Notes:

1. Typical data at $T_A = 25^\circ\text{C}$, $V_{CC} = 5.0$ V dc.
2. Typical performance of circuits shown in Figure 1 and Figure 3 of AN-1038 (see applications support section).

Token Ring 32 MBd Link (HFBR-14X4/24X6)

(refer to Application Note 1065 for details)

Typical Link Performance

Parameter	Symbol	Typ. ^[1,2]	Units	Conditions
Receiver Sensitivity		-34.1	dBm average	32 MBd D2D2 Hexadecimal Data 2 km 62.5/125 μ m fiber
Link Jitter		6.91	ns pk-pk	ECL Out Receiver
		5.52	ns pk-pk	TTL Out Receiver
Transmitter Jitter		0.823	ns pk-pk	32 MBd D2D2 Hexadecimal Data
Optical Power Logic Level "0"	$P_{T,ON}$	-12.2	dBm peak	Transmitter TTL in $I_{F,ON} = 60$ mA, $I_{F,OFF} = 1$ mA
Optical Power Logic Level "1"	$P_{T,OFF}$	-82.2		
LED Rise Time	t_r	1.3	nsec	1 MHz Square Wave Input
LED Fall Time	t_f	3.08	nsec	
Mean Difference	$ t_r - t_f $	1.77	nsec	
Bit Error Rate	BER	10^{-10}		
Data Format 50% Duty Factor		32	MBd	

Notes:

1. Typical data at $T_A = 25^\circ\text{C}$, $V_{CC} = 5.0$ V dc.
2. Typical performance of circuits shown in Figure 1 and Figure 3 of AN-1065 (see applications support section)

155 MBd Link (HFBR-14X4/24X6)

(refer to Application Bulletin 78 for details)

Typical Link Performance

Parameter	Symbol	Typ. ^[1,2]	Units	Max.	Units	Conditions	Ref.
Optical Power Budget with 50/125 μm fiber	OPB ₅₀	7.9	13.9		dB	NA = 0.2	Note 2
Optical Power Budget with 62.5/125 μm fiber	OPB ₆₂	11.7	17.7		dB	NA = 0.27	
Optical Power Budget with 100/140 μm fiber	OPB ₁₀₀	11.7	17.7		dB	NA = 0.30	
Optical Power Budget with 200 μm HCSFiber	OPB ₂₀₀	16.0	22.0		dB	NA = 0.35	
Data Format 20% to 80% Duty Factor		1		175	MBd		
System Pulse Width Distortion	$ \text{t}_{\text{PLH}} - \text{t}_{\text{PHL}} $		1		ns	PR = -7 dBm Peak 1 meter 62.5/125 μm fiber	
Bit Error Rate	BER		10^{-9}			Data Rate < 100 MBaud PR > -31 dBm Peak	Note 2

Notes:

1. Typical data at $T_A = 25^\circ\text{C}$, $V_{CC} = 5.0\text{ V dc}$, PECL serial interface.
2. Typical OPB was determined at a probability of error (BER) of 10^{-9} . Lower probabilities of error can be achieved with short fibers that have less optical loss.

HFBR-14X2/14X4 Low-Cost High-Speed Transmitters

Description

The HFBR-14XX fiber optic transmitter contains an 820 nm AlGaAs emitter capable of efficiently launching optical power into four different optical fiber sizes: 50/125 μm , 62.5/125 μm , 100/140 μm , and 200 μm HCS[®]. This allows the designer flexibility in choosing the fiber size. The HFBR-14XX is designed to operate with the Agilent HFBR-24XX fiber optic receivers.

The HFBR-14XX transmitter's high coupling efficiency allows the emitter to be driven at low current levels resulting in low power consumption and increased reliability of the transmitter. The HFBR-14X4 high power transmitter is optimized for small size fiber and typically can launch

-15.8 dBm optical power at 60 mA into 50/125 μm fiber and -12 dBm into 62.5/125 μm fiber. The HFBR-14X2 standard transmitter typically can launch -12 dBm of optical power at 60 mA into 100/140 μm fiber cable. It is ideal for large size fiber such as 100/140 μm . The high launched optical power level is useful for systems where star couplers, taps, or inline connectors create large fixed losses.

Consistent coupling efficiency is assured by the double-lens optical system (Figure 1). Power coupled into any of the three fiber types varies less than 5 dB from part to part at a given drive current and temperature. Consistent coupling efficiency reduces receiver dynamic range requirements which allows for longer link lengths.

Housed Product

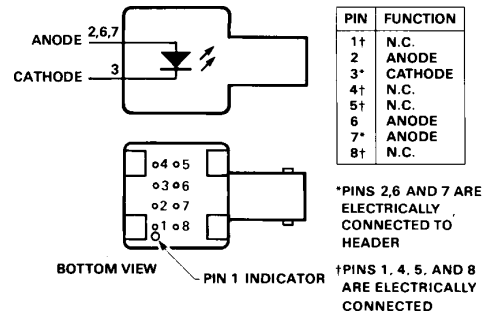

Unhoused Product

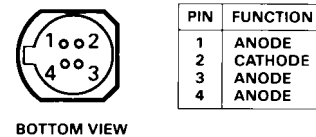

Absolute Maximum Ratings

Parameter	Symbol	Min.	Max.	Units	Reference
Storage Temperature	T_S	-55	+85	$^{\circ}\text{C}$	
Operating Temperature	T_A	-40	+85	$^{\circ}\text{C}$	
Lead Soldering Cycle	Temp.		+260	$^{\circ}\text{C}$	
	Time		10	sec	
Forward Input Current	Peak	I_{FPK}	200	mA	Note 1
	dc	I_{Fdc}	100	mA	
Reverse Input Voltage	V_{BR}		1.8	V	

Electrical/Optical Specifications -40°C to +85°C unless otherwise specified.

Parameter	Symbol	Min.	Typ. ^[2]	Max.	Units	Conditions	Reference
Forward Voltage	V _F	1.48	1.70	2.09	V	I _F = 60 mA dc	Figure 9
			1.84			I _F = 100 mA dc	
Forward Voltage Temperature Coefficient	ΔV _F /ΔT		-0.22		mV/°C	I _F = 60 mA dc	Figure 9
			-0.18			I _F = 100 mA dc	
Reverse Input Voltage	V _{BR}	1.8	3.8		V	I _F = 100 μA dc	
Peak Emission Wavelength	λ _P	792	820	865	nm		
Diode Capacitance	C _T		55		pF	V = 0, f = 1 MHz	
Optical Power Temperature Coefficient	ΔP _T /ΔT		-0.006		dB/°C	I = 60 mA dc	
			-0.010			I = 100 mA dc	
Thermal Resistance	θ _{JA}		260		°C/W		Notes 3, 8
14X2 Numerical Aperture	NA		0.49				
14X4 Numerical Aperture	NA		0.31				
14X2 Optical Port Diameter	D		290		μm		Note 4
14X4 Optical Port Diameter	D		150		μm		Note 4

HFBR-14X2 Output Power Measured Out of 1 Meter of Cable

Parameter	Symbol	Min.	Typ. ^[2]	Max.	Unit	Conditions		Reference
50/125 μm Fiber Cable NA = 0.2	P _{T50}	-21.8	-18.8	-16.8	dBm peak	T _A = 25°C	I _F = 60 mA dc	Notes 5, 6, 9
		-22.8		-15.8				
		-20.3	-16.8	-14.4		T _A = 25°C	I _F = 100 mA dc	
		-21.9		-13.8				
62.5/125 μm Fiber Cable NA = 0.275	P _{T62}	-19.0	-16.0	-14.0	dBm peak	T _A = 25°C	I _F = 60 mA dc	
		-20.0		-13.0				
		-17.5	-14.0	-11.6		T _A = 25°C	I _F = 100 mA dc	
		-19.1		-11.0				
100/140 μm Fiber Cable NA = 0.3	P _{T100}	-15.0	-12.0	-10.0	dBm peak	T _A = 25°C	I _F = 60 mA dc	
		16.0		-9.0				
		-13.5	-10.0	-7.6		T _A = 25°C	I _F = 100 mA dc	
		-15.1		-7.0				
200 μm HCS Fiber Cable NA = 0.37	P _{T200}	-10.7	-7.1	-4.7	dBm peak	T _A = 25°C	I _F = 60 mA dc	
		-11.7		-3.7				
		-9.2	-5.2	-2.3		T _A = 25°C	I _F = 100 mA dc	
		-10.8		-1.7				

CAUTION: The small junction sizes inherent to the design of these components increase the components' susceptibility to damage from electrostatic discharge (ESD). It is advised that normal static precautions be taken in handling and assembly of these components to prevent damage and/or degradation which may be induced by ESD.

HFBR-14X4 Output Power Measured out of 1 Meter of Cable

Parameter	Symbol	Min.	Typ. ^[2]	Max.	Unit	Conditions		Reference
50/125 μm Fiber Cable NA = 0.2	PT50	-18.8	-15.8	-13.8	dBm peak	$T_A = 25^\circ\text{C}$	$I_F = 60 \text{ mA dc}$	Notes 5, 6, 9
		-19.8		-12.8				
		-17.3	-13.8	-11.4		$T_A = 25^\circ\text{C}$	$I_F = 100 \text{ mA dc}$	
		-18.9		-10.8				
62.5/125 μm Fiber Cable NA = 0.275	PT62	-15.0	-12.0	-10.0	dBm peak	$T_A = 25^\circ\text{C}$	$I_F = 60 \text{ mA dc}$	
		-16.0		-9.0				
		-13.5	-10.0	-7.6		$T_A = 25^\circ\text{C}$	$I_F = 100 \text{ mA dc}$	
		-15.1		-7.0				
100/140 μm Fiber Cable NA = 0.3	PT100	-9.5	-6.5	-4.5	dBm peak	$T_A = 25^\circ\text{C}$	$I_F = 60 \text{ mA dc}$	
		-10.5		-3.5				
		-8.0	-4.5	-2.1		$T_A = 25^\circ\text{C}$	$I_F = 100 \text{ mA dc}$	
		-9.6		-1.5				
200 μm HCS Fiber Cable NA = 0.37	PT200	-5.2	-3.7	+0.8	dBm peak	$T_A = 25^\circ\text{C}$	$I_F = 60 \text{ mA dc}$	
		-6.2		+1.8				
		-3.7	-1.7	+3.2		$T_A = 25^\circ\text{C}$	$I_F = 100 \text{ mA dc}$	
		-5.3		+3.8				

14X2/14X4 Dynamic Characteristics

Parameter	Symbol	Min.	Typ. ^[2]	Max.	Units	Conditions	Reference
Rise Time, Fall Time (10% to 90%)	t_r, t_f		4.0	6.5	nsec No Pre-bias	$I_F = 60 \text{ mA}$ Figure 12	Note 7,
Rise Time, Fall Time (10% to 90%)	t_r, t_f		3.0		nsec	$I_F = 10 \text{ to}$ 100 mA	Note 7, Figure 11
Pulse Width Distortion	PWD		0.5		nsec		Figure 11

Notes:

- For $I_{PPK} > 100 \text{ mA}$, the time duration should not exceed 2 ns.
- Typical data at $T_A = 25^\circ\text{C}$.
- Thermal resistance is measured with the transmitter coupled to a connector assembly and mounted on a printed circuit board.
- D is measured at the plane of the fiber face and defines a diameter where the optical power density is within 10 dB of the maximum.
- P_T is measured with a large area detector at the end of 1 meter of mode stripped cable, with an ST® precision ceramic ferrule (MIL-STD-83522/13) for HFBR-1412/1414, and with an SMA 905 precision ceramic ferrule for HFBR-1402/1404.
- When changing μW to dBm, the optical power is referenced to 1 mW (1000 μW). Optical Power P (dBm) = $10 \log P (\mu\text{W})/1000 \mu\text{W}$.
- Pre-bias is recommended if signal rate $> 10 \text{ MBd}$, see recommended drive circuit in Figure 11.
- Pins 2, 6 and 7 are welded to the anode header connection to minimize the thermal resistance from junction to ambient. To further reduce the thermal resistance, the anode trace should be made as large as is consistent with good RF circuit design.
- Fiber NA is measured at the end of 2 meters of mode stripped fiber, using the far-field pattern. NA is defined as the sine of the half angle, determined at 5% of the peak intensity point. When using other manufacturer's fiber cable, results will vary due to differing NA values and specification methods.

All HFBR-14XX LED transmitters are classified as IEC 825-1 Accessible Emission Limit (AEL) Class 1 based upon the current proposed draft scheduled to go in to effect on January 1, 1997. AEL Class 1 LED devices are considered eye safe. Contact your Agilent sales representative for more information.

CAUTION: The small junction sizes inherent to the design of these components increase the components' susceptibility to damage from electrostatic discharge (ESD). It is advised that normal static precautions be taken in handling and assembly of these components to prevent damage and/or degradation which may be induced by ESD.

Recommended Drive Circuits

The circuit used to supply current to the LED transmitter can significantly influence the optical switching characteristics of the LED. The optical rise/fall times and propagation delays can be improved by using the appropriate circuit techniques. The LED drive circuit shown in

Figure 11 uses frequency compensation to reduce the typical rise/fall times of the LED and a small pre-bias voltage to minimize propagation delay differences that cause pulse-width distortion. The circuit will typically produce rise/fall times of 3 ns, and a total jitter including pulse-width distortion of less than 1 ns. This circuit is recommended for applications requiring low edge jitter

or high-speed data transmission at signal rates of up to 155 MBd. Component values for this circuit can be calculated for different LED drive currents using the equations shown below. For additional details about LED drive circuits, the reader is encouraged to read Agilent Application Bulletin 78 and Application Note 1038.

$$R_y = \frac{(V_{CC} - V_F) + 3.97 (V_{CC} - V_F - 1.6 V)}{I_{F ON} (A)}$$

$$R_{X1} = \frac{1}{2} \left(\frac{R_y}{3.97} \right)$$

$$R_{EQ2}(\Omega) = R_{X1} - 1$$

$$R_{X2} = R_{X3} = R_{X4} = 3(R_{EQ2})$$

$$C(\text{pF}) = \frac{2000(\text{ps})}{R_{X1}(\Omega)}$$

Example for $I_{F ON} = 100 \text{ mA}$: V_F can be obtained from Figure 9 (= 1.84 V).

$$R_y = \frac{(5 - 1.84) + 3.97 (5 - 1.84 - 1.6)}{0.100}$$

$$R_y = \frac{3.16 + 6.19}{0.100} = 93.5 \Omega$$

$$R_{X1} = \frac{1}{2} \left(\frac{93.5}{3.97} \right) = 11.8 \Omega$$

$$R_{EQ2} = 11.8 - 1 = 10.8 \Omega$$

$$R_{X2} = R_{X3} = R_{X4} = 3(10.8) = 32.4 \Omega$$

$$C = \frac{2000 \text{ ps}}{11.8 \Omega} = 169 \text{ pF}$$

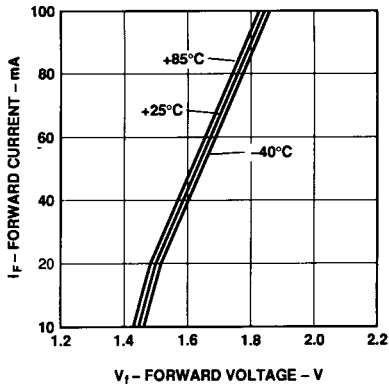

Figure 9. Forward Voltage and Current Characteristics.

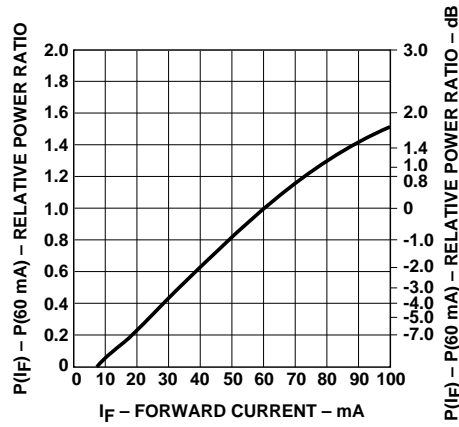

Figure 10. Normalized Transmitter Output vs. Forward Current.

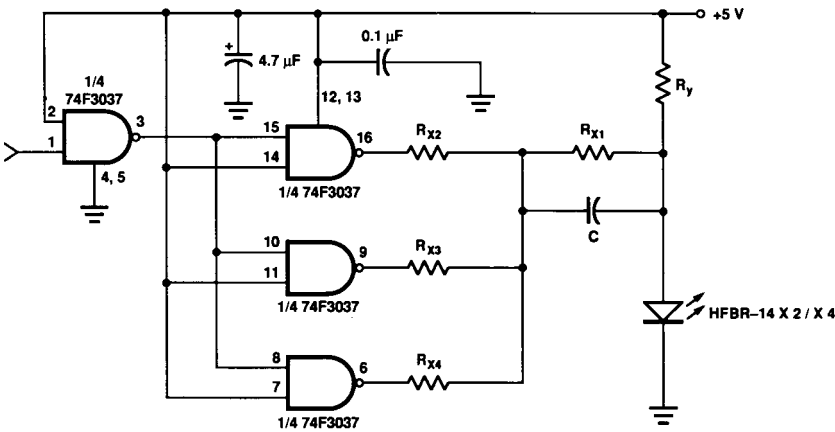

Figure 11. Recommended Drive Circuit.

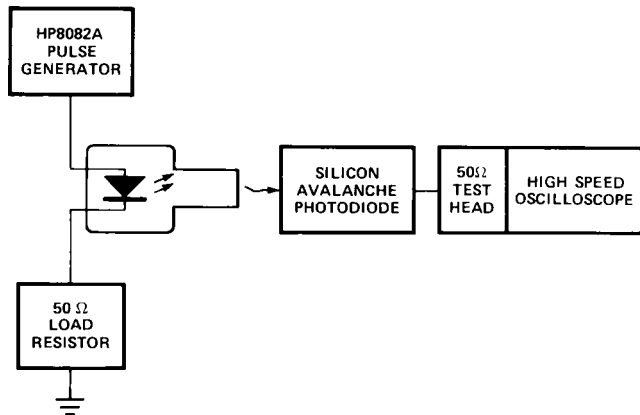

Figure 12. Test Circuit for Measuring t_r , t_f .

HFBR-24X2 Low-Cost 5 MBd Receiver

Description

The HFBR-24X2 fiber optic receiver is designed to operate with the Hewlett-Packard HFBR-14XX fiber optic transmitter and 50/125 μm , 62.5/125 μm , 100/140 μm , and 200 μm HCS[®] fiber optic cable. Consistent coupling into the receiver is assured by the lensed optical system (Figure 1). Response does not vary with fiber size $\leq 0.100 \mu\text{m}$.

The HFBR-24X2 receiver incorporates an integrated photo IC containing a photodetector and dc amplifier driving an open-collector Schottky output transistor. The HFBR-24X2 is

designed for direct interfacing to popular logic families. The absence of an internal pull-up resistor allows the open-collector output to be used with logic families such as CMOS requiring voltage excursions much higher than V_{CC} .

Both the open-collector "Data" output Pin 6 and V_{CC} Pin 2 are referenced to "Com" Pin 3, 7. The "Data" output allows busing, strobing and wired "OR" circuit configurations. The transmitter is designed to operate from a single +5 V supply. It is essential that a bypass capacitor (0.1 μF ceramic) be connected from Pin 2 (V_{CC}) to Pin 3 (circuit common) of the receiver.

Housed Product

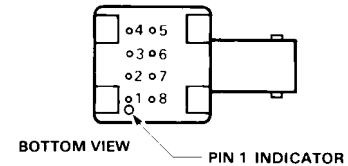
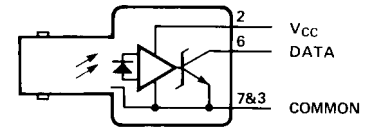

PIN	FUNCTION
1†	N.C.
2	V_{CC} (5 V)
3*	COMMON
4†	N.C.
5†	N.C.
6	DATA
7*	COMMON
8†	N.C.

*PINS 3 AND 7 ARE ELECTRICALLY CONNECTED TO HEADER
 †PINS 1, 4, 5, AND 8 ARE ELECTRICALLY CONNECTED

Unhoused Product

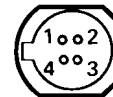

BOTTOM VIEW

PIN	FUNCTION
1	V_{CC} (5 V)
2	COMMON
3	DATA
4	COMMON

Absolute Maximum Ratings

Parameter	Symbol	Min.	Max.	Units	Reference
Storage Temperature	T_S	-55	+85	$^{\circ}\text{C}$	
Operating Temperature	T_A	-40	+85	$^{\circ}\text{C}$	
Lead Soldering Cycle	Temp.		+260	$^{\circ}\text{C}$	Note 1
	Time		10	sec	
Supply Voltage	V_{CC}	-0.5	7.0	V	
Output Current	I_O		25	mA	
Output Voltage	V_O	-0.5	18.0	V	
Output Collector Power Dissipation	P_{OAV}		40	mW	
Fan Out (TTL)	N		5		Note 2

Electrical/Optical Characteristics -40°C to + 85°C unless otherwise specifiedFiber sizes with core diameter $\leq 100 \mu\text{m}$ and $\text{NA} \leq 0.35$, $4.75 \text{ V} \leq V_{\text{CC}} \leq 5.25 \text{ V}$

Parameter	Symbol	Min.	Typ. ^[3]	Max.	Units	Conditions	Reference
High Level Output Current	I_{OH}		5	250	μA	$V_{\text{O}} = 18$ $P_{\text{R}} < -40 \text{ dBm}$	
Low Level Output Voltage	V_{OL}		0.4	0.5	V	$I_{\text{O}} = 8 \text{ mA}$ $P_{\text{R}} > -24 \text{ dBm}$	
High Level Supply Current	I_{CCH}		3.5	6.3	mA	$V_{\text{CC}} = 5.25 \text{ V}$ $P_{\text{R}} < -40 \text{ dBm}$	
Low Level Supply Current	I_{CCL}		6.2	10	mA	$V_{\text{CC}} = 5.25 \text{ V}$ $P_{\text{R}} > -24 \text{ dBm}$	
Equivalent N.A.	NA		0.50				
Optical Port Diameter	D		400		μm		Note 4

Dynamic Characteristics-40°C to +85°C unless otherwise specified; $4.75 \text{ V} \leq V_{\text{CC}} \leq 5.25 \text{ V}$; $\text{BER} \leq 10^{-9}$

Parameter	Symbol	Min.	Typ. ^[3]	Max.	Units	Conditions	Reference
Peak Optical Input Power Logic Level HIGH	P_{RH}			-40	dBm pk	$\lambda_{\text{p}} = 820 \text{ nm}$	Note 5
				0.1	$\mu\text{W pk}$		
Peak Optical Input Power Logic Level LOW	P_{RL}	-25.4		-9.2	dBm pk	$T_{\text{A}} = +25^{\circ}\text{C}$, $I_{\text{OL}} = 8 \text{ mA}$	Note 5
		2.9		120	$\mu\text{W pk}$		
		-24.0		-10.0	dBm pk	$I_{\text{OL}} = 8 \text{ mA}$	
		4.0		100	$\mu\text{W pk}$		
Propagation Delay LOW to HIGH	t_{PLHR}		65		ns	$T_{\text{A}} = 25^{\circ}\text{C}$, $P_{\text{R}} = -21 \text{ dBm}$, Data Rate = 5 MBd	Note 6
Propagation Delay HIGH to LOW	t_{PHLR}		49		ns		

Notes:

- 2.0 mm from where leads enter case.
- 8 mA load (5 x 1.6 mA), $R_{\text{L}} = 560 \Omega$.
- Typical data at $T_{\text{A}} = 25^{\circ}\text{C}$, $V_{\text{CC}} = 5.0 \text{ Vdc}$.
- D is the effective diameter of the detector image on the plane of the fiber face. The numerical value is the product of the actual detector diameter and the lens magnification.
- Measured at the end of 100/140 μm fiber optic cable with large area detector.
- Propagation delay through the system is the result of several sequentially-occurring phenomena. Consequently it is a combination of data-rate-limiting effects and of transmission-time effects. Because of this, the data-rate limit of the system must be described in terms of time differentials between delays imposed on falling and rising edges.
- As the cable length is increased, the propagation delays increase at 5 ns per meter of length. Data rate, as limited by pulse width distortion, is not affected by increasing cable length if the optical power level at the receiver is maintained.

CAUTION: The small junction sizes inherent to the design of these components increase the components' susceptibility to damage from electrostatic discharge (ESD). It is advised that normal static precautions be taken in handling and assembly of these components to prevent damage and/or degradation which may be induced by ESD.

HFBR-24X6 Low-Cost 125 MHz Receiver Description

The HFBR-24X6 fiber optic receiver is designed to operate with the Agilent HFBR-14XX fiber optic transmitters and 50/125 μm , 62.5/125 μm , 100/140 μm and 200 μm HCS[®] fiber optic cable. Consistent coupling into the receiver is assured by the lensed optical system (Figure 1). Response does not vary with fiber size for core diameters of 100 μm or less.

The receiver output is an analog signal which allows follow-on circuitry to be optimized for a variety of distance/data rate requirements. Low-cost external components can be used to convert the analog output to logic compatible signal levels for various data formats and data rates up to 175 MBd. This distance/data rate tradeoff results in increased optical power budget at lower data rates which can be used for additional distance or splices.

The HFBR-24X6 receiver contains a PIN photodiode and low noise transimpedance pre-amplifier

integrated circuit. The HFBR-24X6 receives an optical signal and converts it to an analog voltage. The output is a buffered emitter-follower. Because the signal amplitude from the HFBR-24X6 receiver is much larger than from a simple PIN photodiode, it is less susceptible to EMI, especially at high signaling rates. For very noisy environments, the conductive or metal port option is recommended. A receiver dynamic range of 23 dB over temperature is achievable (assuming 10^{-9} BER).

The frequency response is typically dc to 125 MHz. Although the HFBR-24X6 is an analog receiver, it is compatible with digital systems. Please refer to Application Bulletin 78 for simple and inexpensive circuits that operate at 155 MBd or higher.

The recommended ac coupled receiver circuit is shown in Figure 12. It is essential that a 10 ohm resistor be connected between pin 6 and the power supply, and a 0.1 μF ceramic bypass capacitor be connected between the power supply and ground. In addition, pin 6 should be filtered to protect the

receiver from noisy host systems. Refer to AN 1038, 1065, or AB 78 for details.

Housed Product

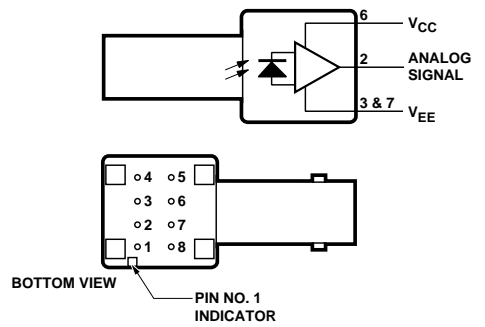

PIN	FUNCTION
1†	N.C.
2	SIGNAL
3*	VEE
4†	N.C.
5†	N.C.
6	VCC
7*	VEE
8†	N.C.

* PINS 3 AND 7 ARE ELECTRICALLY CONNECTED TO THE HEADER.

† PINS 1, 4, 5, AND 8 ARE ISOLATED FROM THE INTERNAL CIRCUITRY, BUT ARE ELECTRICALLY CONNECTED TO EACH OTHER.

Unhoused Product

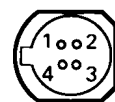

PIN	FUNCTION
1	SIGNAL
2*	VEE
3	VCC
4*	VEE

BOTTOM VIEW

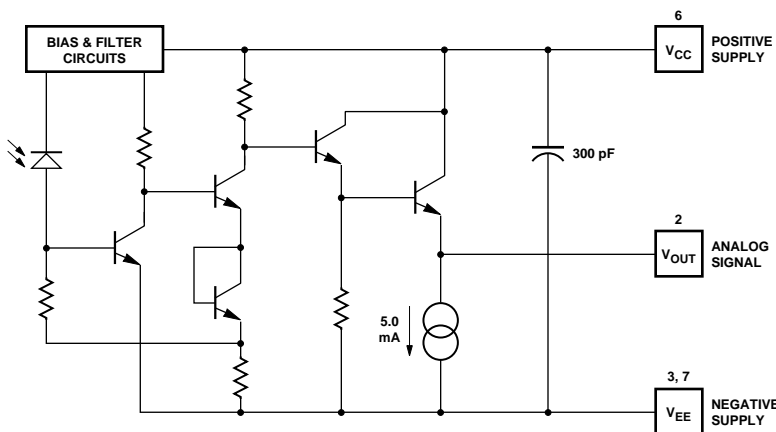

Figure 11. Simplified Schematic Diagram.

CAUTION: The small junction sizes inherent to the design of these components increase the components' susceptibility to damage from electrostatic discharge (ESD). It is advised that normal static precautions be taken in handling and assembly of these components to prevent damage and/or degradation which may be induced by ESD.

Absolute Maximum Ratings

Parameter	Symbol	Min.	Max.	Units	Reference
Storage Temperature	T_S	-55	+85	°C	
Operating Temperature	T_A	-40	+85	°C	
Lead Soldering Cycle	Temp.		+260	°C	Note 1
	Time		10	s	
Supply Voltage	V_{CC}	-0.5	6.0	V	
Output Current	I_O		25	mA	
Signal Pin Voltage	V_{SIG}	-0.5	V_{CC}	V	

Electrical/Optical Characteristics -40°C to +85°C; 4.75 V ≤ Supply Voltage ≤ 5.25 V,
 $R_{LOAD} = 511 \Omega$, Fiber sizes with core diameter ≤ 100 μm, and N.A. ≤ 0.35 unless otherwise specified

Parameter	Symbol	Min.	Typ. ^[2]	Max.	Units	Conditions	Reference
Responsivity	R_P	5.3	7	9.6	mV/μW	$T_A = 25^\circ\text{C}$ @ 820 nm, 50 MHz	Note 3, 4 Figure 16
		4.5		11.5	mV/μW	@ 820 nm, 50 MHz	
RMS Output Noise Voltage	V_{NO}		0.40	0.59	mV	Bandwidth Filtered @ 75 MHz $P_R = 0 \mu\text{W}$	Note 5
				0.70	mV	Unfiltered Bandwidth $P_R = 0 \mu\text{W}$	Figure 13
Equivalent Input Optical Noise Power (RMS)	P_N		-43.0	-41.4	dBm	Bandwidth Filtered @ 75 MHz	
			0.050	0.065	μW		
Optical Input Power (Overdrive)	P_R			-7.6	dBm pk	$T_A = 25^\circ\text{C}$	Figure 14 Note 6
				175	μW pk		
				-8.2	dBm pk		
				150	μW pk		
Output Impedance	Z_o		30		Ω	Test Frequency = 50 MHz	
dc Output Voltage	$V_{o\ dc}$	-4.2	-3.1	-2.4	V	$P_R = 0 \mu\text{W}$	
Power Supply Current	I_{EE}		9	15	mA	$R_{LOAD} = 510 \Omega$	
Equivalent N.A.	NA		0.35				
Equivalent Diameter	D		324		μm		Note 7

CAUTION: The small junction sizes inherent to the design of these components increase the components' susceptibility to damage from electrostatic discharge (ESD). It is advised that normal static precautions be taken in handling and assembly of these components to prevent damage and/or degradation which may be induced by ESD.

Dynamic Characteristics -40°C to +85°C; 4.75 V ≤ Supply Voltage ≤ 5.25 V; R_{LOAD} = 511 Ω, C_{LOAD} = 5 pF unless otherwise specified

Parameter	Symbol	Min.	Typ. ^[2]	Max.	Units	Conditions	Reference
Rise/Fall Time 10% to 90%	t _r , t _f		3.3	6.3	ns	P _R = 100 μW peak	Figure 15
Pulse Width Distortion	PWD		0.4	2.5	ns	P _R = 150 μW peak	Note 8, Figure 14
Overshoot			2		%	P _R = 5 μW peak, t _r = 1.5 ns	Note 9
Bandwidth (Electrical)	BW		125		MHz	-3 dB Electrical	
Bandwidth - Rise Time Product			0.41		Hz • s		Note 10

Notes:

- 2.0 mm from where leads enter case.
- Typical specifications are for operation at T_A = 25°C and V_{CC} = +5 V dc.
- For 200 μm HCS fibers, typical responsivity will be 6 mV/μW. Other parameters will change as well.
- Pin #2 should be ac coupled to a load ≥ 510 ohm. Load capacitance must be less than 5 pF.
- Measured with a 3 pole Bessel filter with a 75 MHz, -3 dB bandwidth. Recommended receiver filters for various bandwidths are provided in Application Bulletin 78.
- Overdrive is defined at PWD = 2.5 ns.
- D is the effective diameter of the detector image on the plane of the fiber face. The numerical value is the product of the actual detector diameter and the lens magnification.
- Measured with a 10 ns pulse width, 50% duty cycle, at the 50% amplitude point of the waveform.
- Percent overshoot is defined as:

$$\left(\frac{V_{PK} - V_{100\%}}{V_{100\%}} \right) \times 100\%$$

- The conversion factor for the rise time to bandwidth is 0.41 since the HFBR-24X6 has a second order bandwidth limiting characteristic.

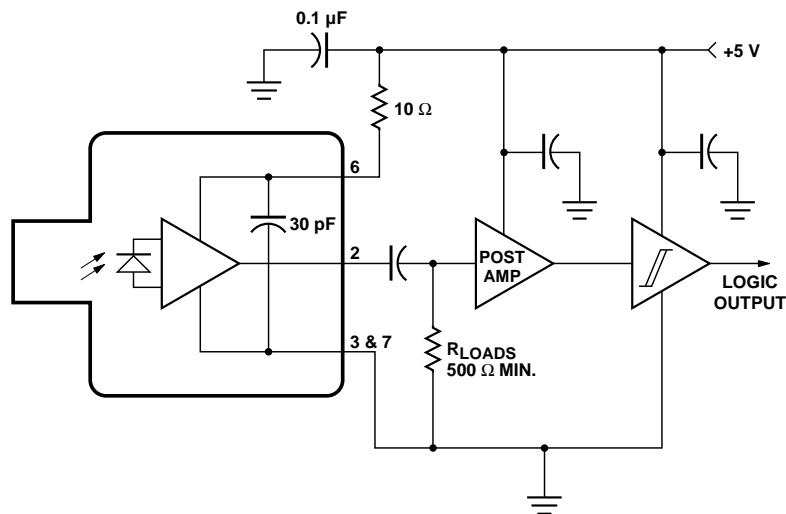

Figure 12. Recommended ac Coupled Receiver Circuit. (See AB 78 and AN 1038 for more information.)

CAUTION: The small junction sizes inherent to the design of these components increase the components' susceptibility to damage from electrostatic discharge (ESD). It is advised that normal static precautions be taken in handling and assembly of these components to prevent damage and/or degradation which may be induced by ESD.

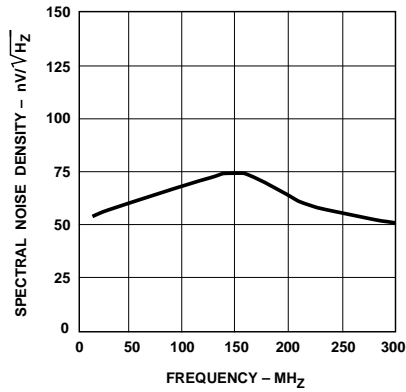

Figure 13. Typical Spectral Noise Density vs. Frequency.

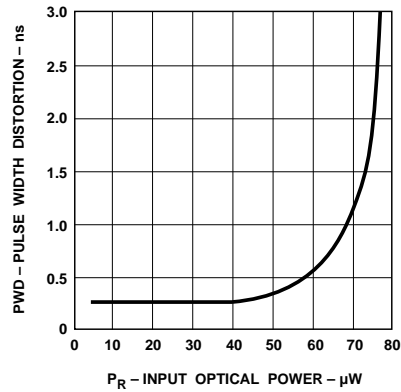

Figure 14. Typical Pulse Width Distortion vs. Peak Input Power.

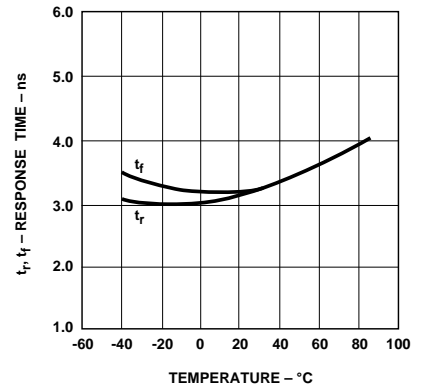

Figure 15. Typical Rise and Fall Times vs. Temperature.

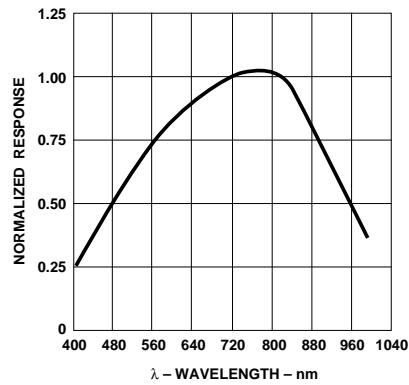

Figure 16. Receiver Spectral Response Normalized to 820 nm.