

Ultra-low Current 2.4V precision analog temperature sensor

Preliminary Data

Feature summary

- Precision analog voltage output temperature sensor
- $\pm 1.5^{\circ}\text{C}$ temperature accuracy at 25°C
- Ultra-low quiescent supply current: $8.0\mu\text{A}$ (max)
- Operating voltage range: 2.4V to 5.5V
- Operating temperature range:
 - 55°C to 130°C (grade - 7)
 - 40°C to 85°C (grade - 9)
- SOT323-5 (SC70-5) 5-lead package
- UDFN 4-lead package

Applications

- Third generation (3G) cell phones
- Multimedia PDA devices
- GPS devices
- Portable medical instruments
- Voltage-controlled crystal oscillator temperature monitors
- RF Power transistor monitor

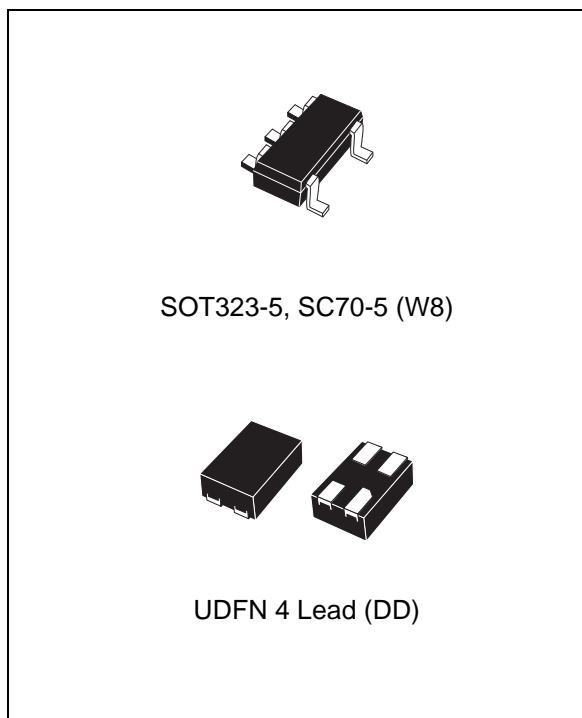

Contents

1	Summary description	5
2	Transfer function	7
3	Maximum rating	9
4	DC and AC characteristics	10
5	Capacitive load	11
6	Typical operating characteristics	12
7	Package mechanical	13
8	Part numbering	15
9	Revision history	16

List of tables

Table 1.	Signal names	5
Table 2.	First order equations optimized for different temperature ranges.	7
Table 3.	Quadratic output equation ($V_{CC} = 2.7V$)	8
Table 4.	Quadratic output equation for operations over the whole voltage range ($V_{CC} = 2.4V$ to $5.5V$)	8
Table 5.	Absolute maximum ratings	9
Table 6.	DC and AC characteristics	10
Table 7.	Resistor/capacitor combinations for the filter network	11
Table 8.	SOT323-5 – 5-lead small outline transistor package mechanical data.	13
Table 9.	UDFN - 4 lead mechanical data	14
Table 10.	Ordering information scheme	15
Table 11.	Marking description.	15
Table 12.	Revision history	16

List of figures

Figure 1.	Logic diagram	5
Figure 2.	Connections (top view)	6
Figure 3.	Filter network for noisy environments or capacitive loads > 300pF	11
Figure 4.	V_{OUT} vs. Temperature	12
Figure 5.	SOT323-5 – 5-lead small outline transistor package outline	13
Figure 6.	UDFN – 4-lead package outline	14

1 Summary description

The STLM20 is a precision analog output temperature sensor for low current applications where maximizing battery life is important. It operates over a -55°C to 130°C (grade 7) or -40°C to 85°C (grade 9) temperature range. The power supply operating range is 2.4V to 5.5V. The accuracy of the STLM20 is $\pm 1.5^{\circ}\text{C}$, at an ambient temperature of 25°C . The temperature error increases linearly and reaches a maximum of $\pm 2.5^{\circ}\text{C}$ at the temperature range extremes. The temperature range is affected by the power supply voltage. For the temperature grade 7 device, a power supply voltage of 2.7V to 5.5V, the temperature range extremes are $+130^{\circ}\text{C}$ and -55°C . Decreasing the power supply voltage to 2.4V changes the negative extreme to -30°C , while the positive remains at $+130^{\circ}\text{C}$.

The STLM20 has a maximum quiescent supply current of $8\mu\text{A}$. Therefore, self-heating is negligible.

Figure 1. Logic diagram

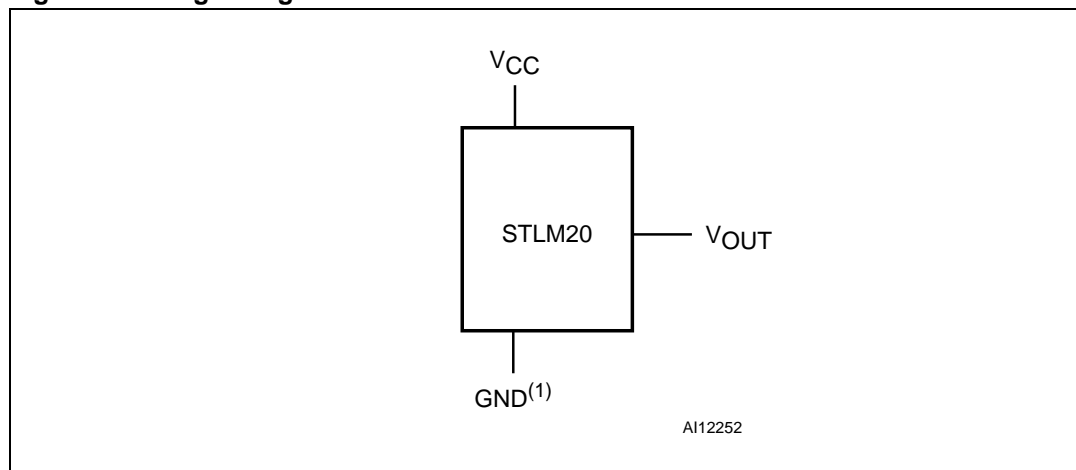

1. Pin 2 GND may be grounded or left floating (SC70-5 only). For optimum thermal conductivity to the PC board ground plane, it should be grounded.

Table 1. Signal names

V _{CC}	Supply voltage
GND	Ground
V _{OUT}	Output voltage
NC	No connect

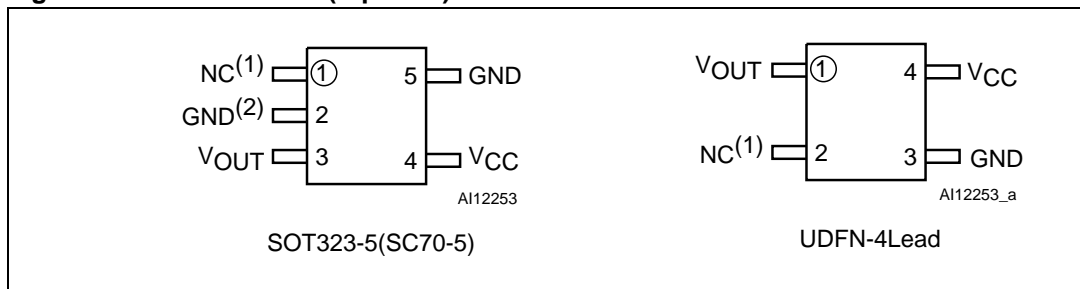
Figure 2. Connections (top view)

1. Pin 1 NC should be left floating or grounded.
2. Pin 2 GND may be grounded or left floating. For optimum thermal conductivity to the PC board ground plane, it should be grounded.

2 Transfer function

The STLM20's transfer function can be described in different ways, with varying levels of precision. A simple linear transfer function, with good accuracy near 25°C is expressed as:

Equation 1

$$V_O = (-11.69\text{mV})/\text{ }^\circ\text{C} \times T + 1.8663\text{V}$$

Over the specified operating temperature range, the best accuracy can be obtained by using the parabolic transfer function:

Equation 2

$$V_O = (-3.88 \times 10^{-6} \times T^2) + (-1.15 \times 10^{-2} \times T) + 1.8639$$

and solving for T:

Equation 3

$$T = -1481.96 + \sqrt{2.1962 \times 10^6 + \frac{(1.8639 - V_O)}{3.88 \times 10^{-6}}}$$

The best fit linear transfer function for many popular temperature ranges was calculated in [Table 2](#), where the error introduced by the linear transfer function increases with wider temperature ranges.

Table 2. First order equations optimized for different temperature ranges

Temperature range		Linear equation $V_O =$	Maximum deviation of linear equation from parabolic equation (°C)
T_{\min} (°C)	T_{\max} (°C)		
-55	130	$-11.79\text{mV}/\text{ }^\circ\text{C} * T + 1.8528\text{V}$	± 1.41
-40	110	$-11.77\text{mV}/\text{ }^\circ\text{C} * T + 1.8577\text{V}$	± 0.93
-30	100	$-11.77\text{mV}/\text{ }^\circ\text{C} * T + 1.8605\text{V}$	± 0.70
-40	85	$-11.67\text{mV}/\text{ }^\circ\text{C} * T + 1.8583\text{V}$	± 0.65
-10	65	$-11.71\text{mV}/\text{ }^\circ\text{C} * T + 1.8641\text{V}$	± 0.23
35	45	$-11.81\text{mV}/\text{ }^\circ\text{C} * T + 1.8701\text{V}$	± 0.004
20	30	$-11.69\text{mV}/\text{ }^\circ\text{C} * T + 1.8663\text{V}$	± 0.004

Table 3. Quadratic output equation ($V_{CC} = 2.7V$)

Parameter	Conditions	Min	Typ	Max	Unit
Temperature error based on: $V_{OUT} = (-3.88e^{-6} \times T^2) + (-1.15e^{-2} \times T) + 1.8639$ where T is the temperature	$T_A = -55^{\circ}C$	2.457	2.485	2.512	V
	$T_A = -40^{\circ}C$	2.292	2.318	2.343	
	$T_A = -30^{\circ}C$	2.181	2.205	2.230	
	$T_A = -20^{\circ}C$	2.069	2.092	2.116	
	$T_A = 0^{\circ}C$	1.842	1.864	1.886	
	$T_A = 25^{\circ}C$	1.556	1.574	1.592	
	$T_A = 50^{\circ}C$	1.255	1.279	1.303	
	$T_A = 85^{\circ}C$	0.833	0.859	0.884	
	$T_A = 130^{\circ}C$	0.272	0.303	0.335	

Table 4. Quadratic output equation for operations over the whole voltage range ($V_{CC} = 2.4V$ to $5.5V$)

Parameter ⁽¹⁾	Conditions	Min	Max	Unit
Temperature error based on: $V_{OUT} = (-3.88e^{-6} \times T^2) + (-1.15e^{-2} \times T) + 1.8639$, where T is the temperature	$T_A = -55^{\circ}C^{(2) (3)}$	2.457	2.531	V
	$T_A = -40^{\circ}C^{(2)}$	2.292	2.362	
	$T_A = -30^{\circ}C$	2.180	2.249	
	$T_A = -20^{\circ}C$	2.068	2.135	
	$T_A = 0^{\circ}C$	1.841	1.904	
	$T_A = 25^{\circ}C$	1.555	1.610	
	$T_A = 50^{\circ}C$	1.254	1.322	
	$T_A = 85^{\circ}C$	0.832	0.903	
	$T_A = 130^{\circ}C^{(3)}$	0.271	0.353	

1. V_{OUT} tolerance is $\pm 4\%$ (temperature grade 9 only).
2. Valid for V_{CC} min = 2.7V.
3. Valid for temperature grade 7 only.

3 Maximum rating

Stressing the device above the rating listed in the Absolute Maximum Ratings” table may cause permanent damage to the device. These are stress ratings only and operation of the device at these or any other conditions above those indicated in the Operating sections of this specification is not implied. Exposure to Absolute Maximum Rating conditions for extended periods may affect device reliability. Refer also to the STMicroelectronics SURE Program and other relevant quality documents.

Table 5. Absolute maximum ratings

Symbol	Parameter	Value	Unit	
T_{STG}	Storage temperature	-65 to +150	°C	
$T_{SLD}^{(1)}$	Lead solder temperature for 10 seconds	260	°C	
V_O	Output voltage	-0.6 to $V_{CC} + 0.6$	V	
V_{CC}	Supply voltage	-0.2 to 6.5	V	
I_O	Output current	10	mA	
$T_{J(max)}$	Maximum junction temperature	150	°C	
P_D	Power dissipation	377	mW	
$T_A^{(2)}$	Ambient operating temperature	Grade 7	-55 to 130	°C
		Grade 9	-40 to 85	°C

1. Reflow at peak temperature of 255°C to 260°C for < 30 seconds (total thermal budget not to exceed 180°C for between 90 to 150 seconds).
2. Grade 7: STLM20DD7F and STLM20W87F
Grade 9: STLM20DD9F and STLM20W89F.

4 DC and AC characteristics

This section summarizes the DC and AC characteristics of the device. The parameters in the DC and AC characteristics table that follows are derived from tests performed under the test conditions (see [Table 6 on page 10](#)). Designers should check that the operating conditions in their circuit match the operating conditions when relying on the quoted parameters.

Table 6. DC and AC characteristics

Sym	Description	Test condition ⁽¹⁾	Min	Typ ⁽²⁾	Max	Unit
V _{CC}	Supply voltage	T _A = -30°C to 130°C	2.4		5.5	V
		T _A = -55°C to 130°C or -40°C to 85°C	2.7		5.5	V
V _O	Output voltage	T _A = 0°C		1.8639		V
	Temperature to voltage error ⁽³⁾ V _O = (-3.88E-6 * T2) + (-1.15E-2 * T) + 1.8639V	T _A = 25°C to 30°C			±1.5	°C
		T _A = 125°C to 130°C			±2.5	°C
		T _A = 80°C to 85°C			±2.1	°C
		T _A = 0°C			±1.9	°C
		T _A = -40°C			±2.3	°C
		T _A = -55°C			±2.5	°C
I _Q	Quiescent current	2.4V ≤ V _{CC} ≤ 5.5V		4.8	8	µA
	Sensor gain (temperature sensitivity or average slope), V _O = -11.77mV/°C * T + 1.860V	-30°C ≤ T _A ≤ 100°C	-11.4	-11.77	-12.2	mV/°C
	Non-linearity	-20°C ≤ T _A ≤ 80°C		±0.4		%
ΔI _Q	Change of quiescent current	2.4V ≤ V _{CC} ≤ 5.5V		0.7		µA
T _C V _O	Temperature coefficient of quiescent current			-11		nA/°C
I _{SD}	Shutdown current	V _{CC} ≤ 0.8V		0.02		µA
Z _O	Output impedance	0µA ≤ I _L ≤ 16µA ⁽⁴⁾⁽⁵⁾			160	Ω
RegL	Load regulation ⁽⁶⁾				-2.5	mV
Regl1	Line regulation	2.4V ≤ V _{CC} ≤ 5.0V			3.3	mV/V
Regl2		5.0V ≤ V _{CC} ≤ 5.5V			11	mV

- Valid for Ambient Operating Temperature: T_A = -55 to 130°C or T_A = -40 to 85°C; V_{CC} = 2.7V (except where noted).
- T_J = T_A = 25°C.
- Error accuracy is between the measured and calculated output voltage at specified conditions of voltage, current, and temperature.
- With negative current flowing into STLM20 and positive current flowing out, can typically sink less than 1µA and source is 16µA.
- Over the supply range of 2.4 to 5.5V.
- Measured at constant junction temperature, with pulse testing and low duty cycle. Output changes due to heating may be calculated by multiplying internal dissipation by thermal resistance.

5 Capacitive load

The STLM20 will handle capacitive loads of up to 300pF. Over the specified temperature range, the STLM20 has a maximum output impedance of 160Ω

In a noisy environment, it may be advisable to add some filtering to minimize noise in the output voltage. A 0.1μF capacitor added between the supply voltage and ground is recommended.

In an extremely noisy environment, it may be necessary to add a low-pass filter network to the output of the device. A 1μF capacitor, in addition to the output impedance of the device, and a 200Ω series resistor, will provide a low-pass filter that will pass the slow thermal time constant of the STLM20, while filtering the higher frequency noise.

Figure 3. Filter network for noisy environments or capacitive loads > 300pF

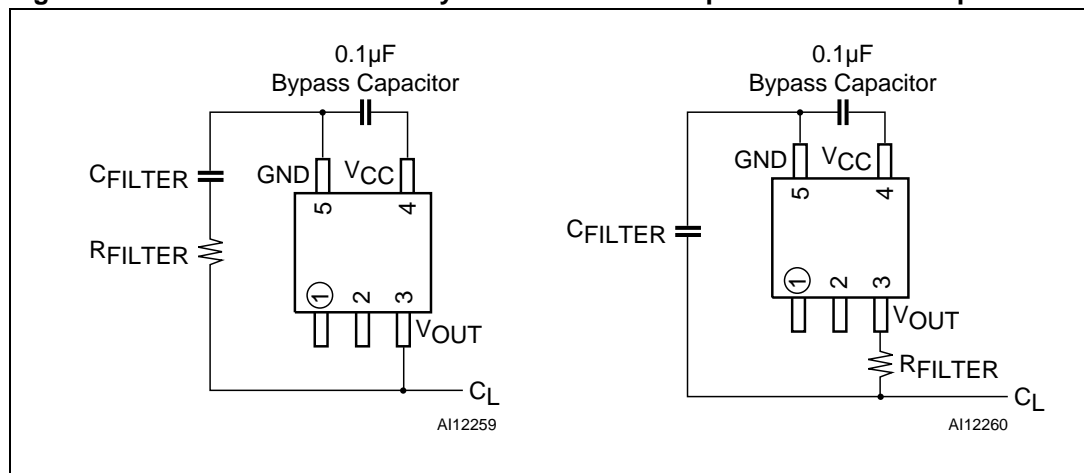

Table 7. Resistor/capacitor combinations for the filter network

R_{FILTER}	C_{FILTER}
200Ω	1μF
470Ω	0.1μF
680Ω	0.01μF
1000Ω	1000pF
10kΩ	100pF
100kΩ	10pF

6 Typical operating characteristics

The graph shown in [Figure 6](#) represents V_{OUT} according to temperature.

Figure 4. V_{OUT} vs. Temperature

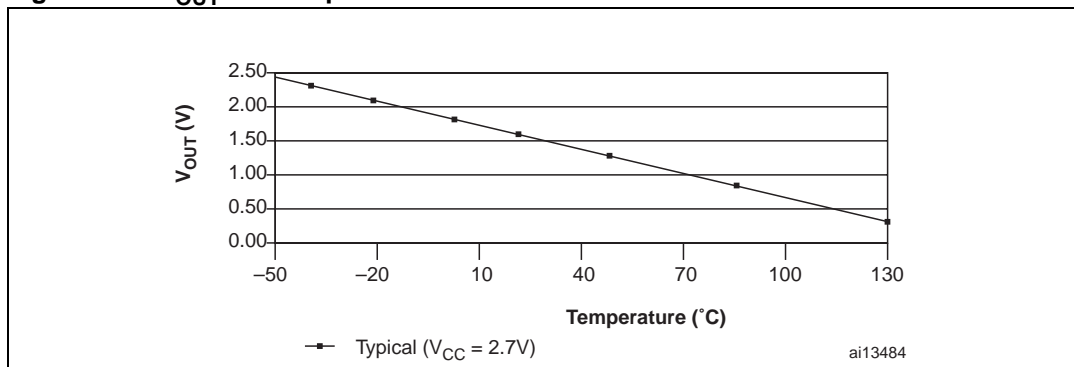

7 Package mechanical

In order to meet environmental requirements, ST offers these devices in ECOPACK[®] packages. These packages have a Lead-free second level interconnect. The category of second Level Interconnect is marked on the package and on the inner box label, in compliance with JEDEC Standard JESD97. The maximum ratings related to soldering conditions are also marked on the inner box label. ECOPACK is an ST trademark. ECOPACK specifications are available at: www.st.com.

Figure 5. SOT323-5 – 5-lead small outline transistor package outline

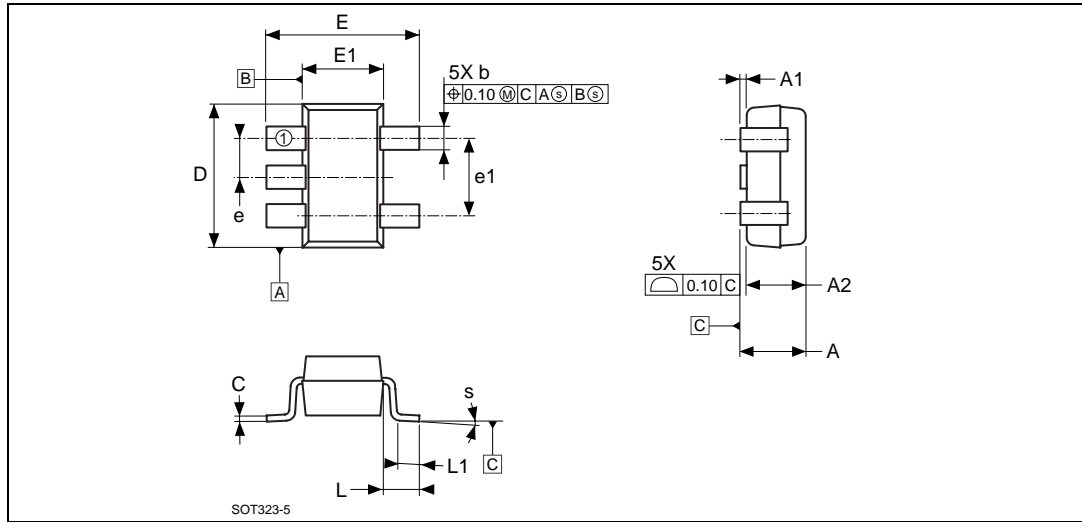

1. Drawing is not to scale.

Table 8. SOT323-5 – 5-lead small outline transistor package mechanical data

Symbol	mm			inches		
	Typ	Min	Max	Typ	Min	Max
A	–	0.80	1.10	–	0.031	0.043
A1	–	0	0.10	–	0	0.004
A2	0.90	–	–	0.035	–	–
b	–	0.15	0.30	–	0.006	0.012
C	–	0.10	0.20	–	0.004	0.008
D	2.00	1.90	2.10	0.079	0.075	0.083
E	–	1.80	2.40	–	0.071	0.094
E1	1.25	1.15	1.35	0.049	0.045	0.053
e	0.65	–	–	0.026	–	–
e1	1.30	–	–	0.051	–	–
L	0.52	–	–	0.020	–	–
L1	0.40	0.35	0.45	0.016	0.014	0.018
s	–	0°	5°	–	0°	5°

Figure 6. UDFN – 4-lead package outline

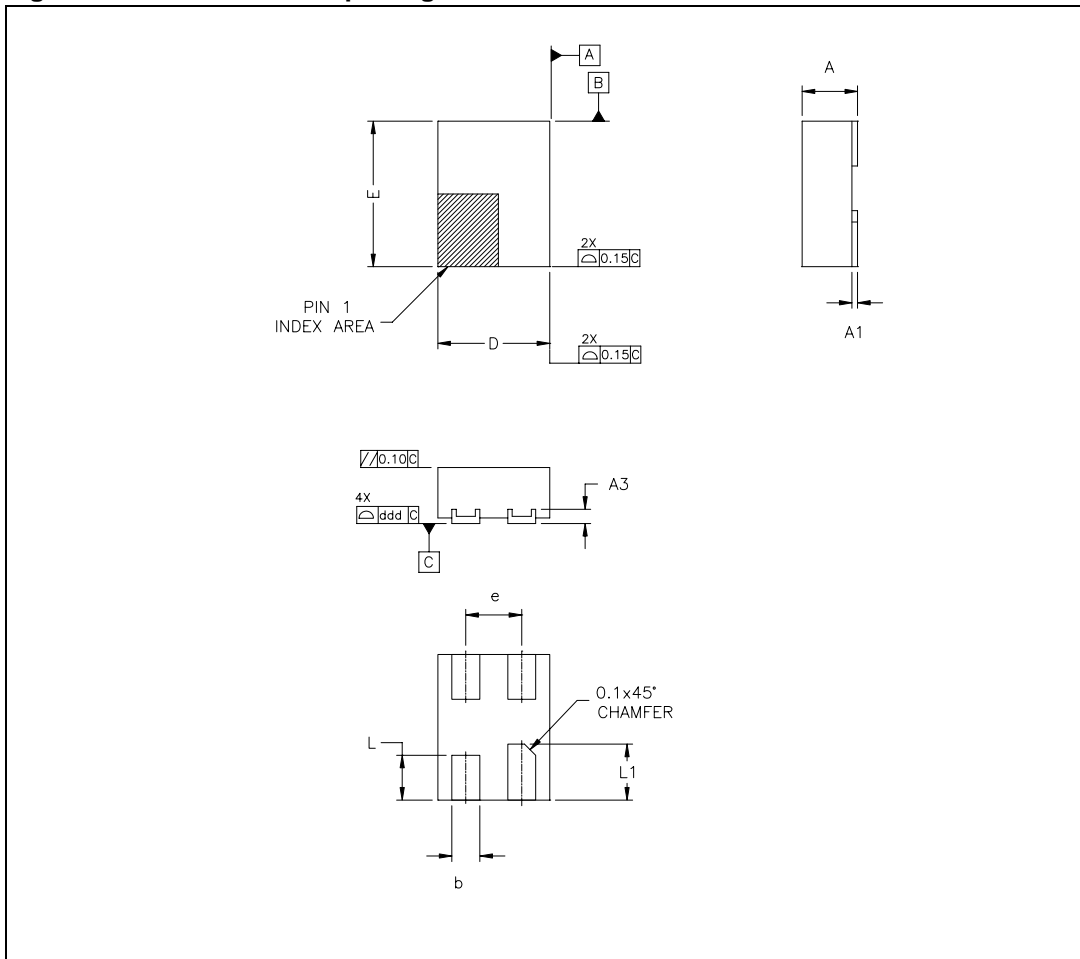

1. Drawing is not to scale.

Table 9. UDFN - 4 lead mechanical data

Symbol	mm			inches		
	Min	Typ	Max	Min	Typ	Max
A	0.45	0.50	0.55	0.018	0.020	0.022
A1	0	0.025	0.05	0	0.001	0.002
A3	0.119	0.127	0.177	0.0046	0.0050	0.0069
b	0.20	0.25	0.30	0.008	0.010	0.012
D	0.95	1.00	1.05	0.037	0.039	0.041
E	1.25	1.30	1.35	0.049	0.051	0.053
e	0.45	0.50	0.55	0.018	0.020	0.022
L	0.35	0.40	0.45	0.014	0.016	0.018
L1	0.45	0.50	0.55	0.018	0.020	0.022
ddd	0	0.04	0.08	0	0.0016	0.0031

8 Part numbering

Table 10. Ordering information scheme

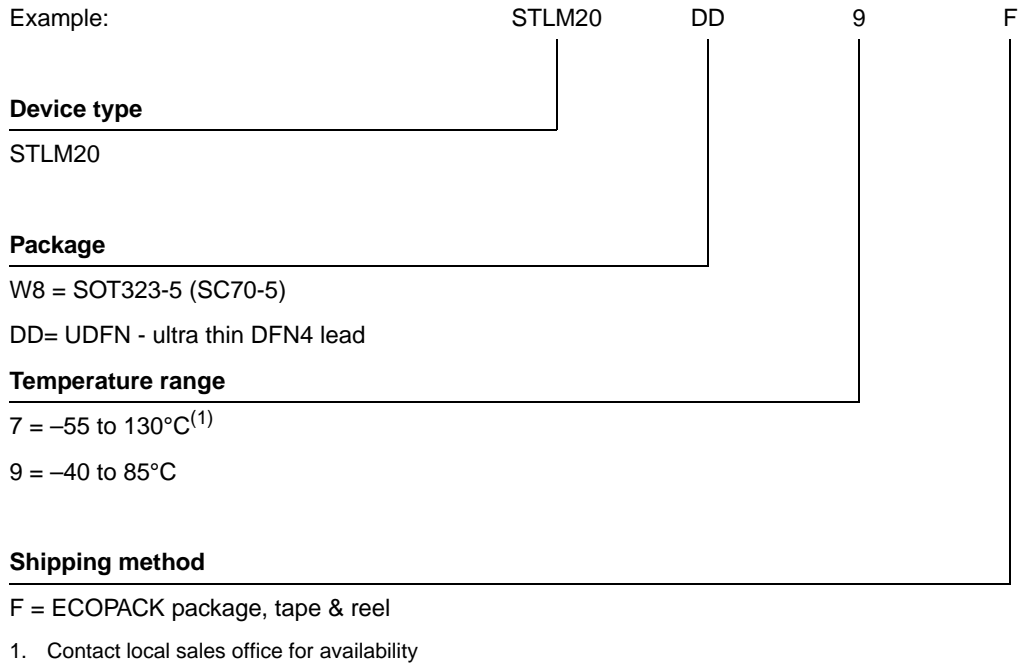

Table 11. Marking description

Part number	Package	Marking
STLM20W8	SOT323-5(SC70)	M20
STLM20DD	UDFN	20

For other options, or for more information on any aspect of this device, please contact the ST Sales Office nearest you.

9 Revision history

Table 12. Revision history

Date	Revision	Changes
28-Jun-2006	1	Initial release.
19-Jul-2006	2	Added Table 11: Marking description
28-Aug-2006	3	Added a footnote concerning package availability in Feature summary on page 1 and to Table 10 and Table 11 ; updated package mechanical data in Table 9
05-Sep-2006	4	Amended text in the Feature summary on page 1 , Section 1: Summary description , Section 2: Transfer function , Table 6 , and Table 10 to elucidate that two packages exist each with specific temperature ranges: SOT323-5 (SC70-5) 5-lead package (–55 to 130°C) and UDFN 4-lead package (–40 to 85°C)
25-Sep-2006	5	Updated Operating Temperature Ranges (now 7 and 9); updated Table 6: DC and AC characteristics
10-Oct-2006	6	Table 3: Quadratic output equation ($V_{CC} = 2.7V$) and Table 4: Quadratic output equation for operations over the whole voltage range ($V_{CC} = 2.4V$ to $5.5V$) added. Section 6: Typical operating characteristics added. T_A added to Table 5: Absolute maximum ratings .

Please Read Carefully:

Information in this document is provided solely in connection with ST products. STMicroelectronics NV and its subsidiaries ("ST") reserve the right to make changes, corrections, modifications or improvements, to this document, and the products and services described herein at any time, without notice.

All ST products are sold pursuant to ST's terms and conditions of sale.

Purchasers are solely responsible for the choice, selection and use of the ST products and services described herein, and ST assumes no liability whatsoever relating to the choice, selection or use of the ST products and services described herein.

No license, express or implied, by estoppel or otherwise, to any intellectual property rights is granted under this document. If any part of this document refers to any third party products or services it shall not be deemed a license grant by ST for the use of such third party products or services, or any intellectual property contained therein or considered as a warranty covering the use in any manner whatsoever of such third party products or services or any intellectual property contained therein.

UNLESS OTHERWISE SET FORTH IN ST'S TERMS AND CONDITIONS OF SALE ST DISCLAIMS ANY EXPRESS OR IMPLIED WARRANTY WITH RESPECT TO THE USE AND/OR SALE OF ST PRODUCTS INCLUDING WITHOUT LIMITATION IMPLIED WARRANTIES OF MERCHANTABILITY, FITNESS FOR A PARTICULAR PURPOSE (AND THEIR EQUIVALENTS UNDER THE LAWS OF ANY JURISDICTION), OR INFRINGEMENT OF ANY PATENT, COPYRIGHT OR OTHER INTELLECTUAL PROPERTY RIGHT.

UNLESS EXPRESSLY APPROVED IN WRITING BY AN AUTHORIZED ST REPRESENTATIVE, ST PRODUCTS ARE NOT RECOMMENDED, AUTHORIZED OR WARRANTED FOR USE IN MILITARY, AIR CRAFT, SPACE, LIFE SAVING, OR LIFE SUSTAINING APPLICATIONS, NOR IN PRODUCTS OR SYSTEMS WHERE FAILURE OR MALFUNCTION MAY RESULT IN PERSONAL INJURY, DEATH, OR SEVERE PROPERTY OR ENVIRONMENTAL DAMAGE. ST PRODUCTS WHICH ARE NOT SPECIFIED AS "AUTOMOTIVE GRADE" MAY ONLY BE USED IN AUTOMOTIVE APPLICATIONS AT USER'S OWN RISK.

Resale of ST products with provisions different from the statements and/or technical features set forth in this document shall immediately void any warranty granted by ST for the ST product or service described herein and shall not create or extend in any manner whatsoever, any liability of ST.

ST and the ST logo are trademarks or registered trademarks of ST in various countries.

Information in this document supersedes and replaces all information previously supplied.

The ST logo is a registered trademark of STMicroelectronics. All other names are the property of their respective owners.

© 2006 STMicroelectronics - All rights reserved

STMicroelectronics group of companies

Australia - Belgium - Brazil - Canada - China - Czech Republic - Finland - France - Germany - Hong Kong - India - Israel - Italy - Japan - Malaysia - Malta - Morocco - Singapore - Spain - Sweden - Switzerland - United Kingdom - United States of America

www.st.com

